



To: HOLDERS OF COMPONENT MAINTENANCE MANUAL 24-32-06, 1756-1 and 1756-3

Subject: CMM Revision No. 6 Dated May 15/2023

Replace revised pages by adding and removing pages for pages dated May 15/2023.

NOTE: The CMM can be downloaded from the internet at www.saftbatteries.com

HIGHLIGHTS

CHAPTER/SECTION PAGE NUMBER	DESCRIPTION OF CHANGE
Title Page T-1	Add Revision 6 with Date, rearranged wording, and updated website
Record of Revisions ROR 1	Add revision 6
List of Effective Pages LEP 1	Corrected/Changed pages
Service Bulletin List SBL 1	Updated information
Introduction Intro 1 – Intro 2, Intro 4	Updated website
Testing and Fault Isolation 1002 – 1003	Update chart
Testing and Fault Isolation 1005 - 1006	Update visual inspection procedures and add vent valve O-ring from repair section, updated insulation steps
Testing and Fault Isolation 1007	Updated information based on disassembly and assembly and elimination from repair section
Testing and Fault Isolation 1008 - 1013	Clarifications, repaginate
Testing and Fault Isolation 1014	Relocated lower nut tightness from repair section
Testing and Fault Isolation 1015, 1017	Update remedy
Disassembly 3001	Clarification
Check 5001	Clarifications
Repair 6001 - 6002	Remove items that were covered under disassembly and assembly sections
Assembly 7003	Correction and clarifications

24-32-06

Highlights Page 1 of 2

May 15/2023



PAGE INTENTIONALLY LEFT BLANK



ECCN: EAR99
CAGE Code 09052
711 GIL HARBIN INDUSTRIAL BOULEVARD
VALDOSTA, GEORGIA 31601
Phone: +1 (229) 247-2331 Fax: +1 (229) 247-8486

COMPONENT MAINTENANCE MANUAL

WITH ILLUSTRATED PARTS LIST

Nickel Cadmium Aircraft Battery

Aircraft Battery

1756-1 and 1756-3

Website: www.saft.com

24-32-06

T-1
REV 6 May 15/2023



COMPONENT MAINTENANCE MANUAL
1756-1 and 1756-3

This document and all information contained herein are the property of Saft. Its use is restricted solely to the maintenance of Saft batteries and may under no circumstances be used for any other manufacturer's products. No person may, in whole or in part, duplicate, use or disclose this information for any other purpose without the prior written consent of Saft.

24-32-06

T- 2
Mar 14/2022



COMPONENT MAINTENANCE MANUAL
1756-1 and 1756-3

RECORD OF REVISIONS

REV NO.	ISSUE DATE	INSERT DATE	BY	REV NO.	ISSUE DATE	INSERT DATE	BY
1	02/01/99	02/01/99	Saft				
2	Feb 26/20	Feb 26/20	Saft				
3	Apr 16/21	Apr 16/21	Saft				
4	Mar 14/2022	Mar 14/2022	Saft				
5	Nov 1/2022	Nov 1/2022	Saft				
6	May 15/2023	May 15/2023	Saft				



COMPONENT MAINTENANCE MANUAL
1756-1 and 1756-3

PAGE INTENTIONALLY LEFT BLANK

24-32-06

ROR 2
Mar 14/2022



COMPONENT MAINTENANCE MANUAL
1756-1 and 1756-3

RECORD OF TEMPORARY REVISIONS

TEMPORARY REV NO	ISSUE DATE	INSERTED DATE / INSERTED BY	DATE REMOVED / REMOVED BY	DATE INCORPORATED
24-4	Oct 11/05	-	-	Feb 26/20
24-6	Jan 13/06	-	-	Feb 26/20



COMPONENT MAINTENANCE MANUAL
1756-1 and 1756-3

PAGE INTENTIONALLY LEFT BLANK

24-32-06

RTR 2
Mar 14/2022



COMPONENT MAINTENANCE MANUAL
1756-1 and 1756-3

SERVICE BULLETIN LIST

SERVICE BULLETIN		DATE	TITLE
NUMBER / REV	DATE	INCORPORATION OR NO EFFECT	
SAI0398 / A	Mar 27/1998	Feb 1/1999	Convert 1756-1 to 1756-3.
SB0516 / D	Jan 30/2023	No Effect	Inspection of latch clearances

24-32-06

SBL 1
May 15/2023



COMPONENT MAINTENANCE MANUAL
1756-1 and 1756-3

PAGE INTENTIONALLY LEFT BLANK

24-32-06

SBL 2
Mar 14/2022



COMPONENT MAINTENANCE MANUAL
1756-1 and 1756-3

LIST OF EFFECTIVE PAGES

<u>SUBJECT</u>	<u>PAGE</u>	<u>DATE</u>	<u>SUBJECT</u>	<u>PAGE</u>	<u>DATE</u>
TITLE PAGE	T-1	May 15/2023		1014	May 15/2023
	T-2	Mar 14/2022		1015	May 15/2023
RECORD OF REVISIONS	ROR 1	May 15/2023		1016	Nov 1/2022
	ROR 2	Blank		1017	May 15/2023
RECORD OF TEMPORARY REVISIONS	RTR 1	Nov 1/2022		1018	Blank
	RTR 2	Blank		DISASSEMBLY	3001
SERVICE BULLETIN LIST	SBL 1	May 15/2023		3002	Blank
	SBL 2	Blank		CLEANING	4001
LIST OF EFFECTIVE PAGES	LEP 1	May 15/2023	4002	Nov 1/2022	
	LEP 2	Blank	CHECK	5001	May 15/2023
TABLE OF CONTENTS	TOC 1	Mar 14/2022	5002	Mar 14/2022	
	TOC 2	Blank	REPAIR	6001	May 15/2023
LIST OF ILLUSTRATIONS	LOI 1	Nov 1/2022	6002	May 15/2023	
	LOI 2	Blank	ASSEMBLY	7001	Nov 1/2022
LIST OF TABLES	LOT 1	Mar 14/2022	7002	Mar 14/2022	
	LOT 2	Blank	7003	May 15/2023	
INTRODUCTION	Intro 1	May 15/2023	7004	Blank	
	Intro 2	May 15/2023	FITS AND CLEARANCES	8001	Mar 14/2022
	Intro 3	Nov 1/2022	8002	Blank	
	Intro 4	May 15/2023	SPECIAL TOOLS, FIXTURES, EQUIPMENT, AND CONSUMABLES	9001	Nov 1/2022
DESCRIPTION AND OPERATION	1	Mar 14/2022	9002	Mar 14/2022	
	2	Mar 14/2022	9003	Nov 1/2022	
	3	Mar 14/2022	9004	Mar 14/2022	
	4	Mar 14/2022	ILLUSTRATED PARTS LIST	10001	Mar 14/2022
TESTING AND FAULT ISOLATION	1001	Nov 1/2022	10002	Nov 1/2022	
	1002	May 15/2023	10003	Mar 14/2022	
	1003	May 15/2023	10004	Nov 1/2022	
	1004	Nov 1/2022	10005	Nov 1/2022	
	1005	May 15/2023	10006	Nov 1/2022	
	1006	May 15/2023	10007	Nov 1/2022	
	1007	May 15/2023	10008	Nov 1/2022	
	1008	May 15/2023	STORAGE (INCLUDING TRANSPORTATION)	15001	Mar 14/2022
	1009	May 15/2023	15002	Nov 1/2022	
	1010	May 15/2023	15003	Nov 1/2022	
	1011	May 15/2023	15004	Nov 1/2022	
	1012	May 15/2023	15005	Nov 1/2022	
	1013	May 15/2023	15006	Blank	

24-32-06

LEP 1
May 15/2023



COMPONENT MAINTENANCE MANUAL
1756-1 and 1756-3

PAGE INTENTIONALLY LEFT BLANK

24-32-06

LEP 2
Mar 14/2022



COMPONENT MAINTENANCE MANUAL
1756-1 and 1756-3

TABLE OF CONTENTS

PARAGRAPH TITLE	PAGE
INTRODUCTION	Intro 1
DESCRIPTION AND OPERATION	1
TESTING AND FAULT ISOLATION	1001
AUTOMATIC TEST REQUIREMENTS (ATLAS)	N/A
DISASSEMBLY	3001
CLEANING	4001
INSPECTION/CHECK	5001
REPAIR	6001
ASSEMBLY	7001
FITS AND CLEARANCES	8001
SPECIAL TOOLS, FIXTURES, EQUIPMENT, AND CONSUMABLES	9001
ILLUSTRATED PARTS LIST	10001
STORAGE (INCLUDING TRANSPORTATION)	15001



COMPONENT MAINTENANCE MANUAL
1756-1 and 1756-3

PAGE INTENTIONALLY LEFT BLANK

24-32-06

TOC 2
Mar 14/2022



COMPONENT MAINTENANCE MANUAL
1756-1 and 1756-3

LIST OF ILLUSTRATIONS

FIGURE	DESCRIPTION	PAGE
Intro 1	Universal Recycling Symbols	Intro-4
1	1756-1 and 1756-3 Battery	1
1001	Periodical Check	1002
1002	Regular Check	1003
1003	General Overhaul	1004
1004	Position of T02 in Cell Vent Seat	1010
1005	Connector Pinout	1012
1006	Special Testing Flow Chart	1014
7001	Battery Spacer Kit (020)	7001
7002	Battery Circuit	7003
9001	Vent Valve Wrench	9001
9002	20cm ³ Syringe	9002
9003	Cell Extraction Wrench	9002
IPL Figure 1	Battery, Exploded View (Sheet 1 of 4)	10004
IPL Figure 1	Battery, Exploded View (Sheet 2 of 4)	10005
IPL Figure 1	Battery, Exploded View (Sheet 3 of 4)	10006
IPL Figure 1	Battery, Exploded View (Sheet 4 of 4)	10007
15001	Standby Period	15002
15002	Inactive Standby Storage Schedule	15003



COMPONENT MAINTENANCE MANUAL
1756-1 and 1756-3

PAGE INTENTIONALLY LEFT BLANK

24-32-06

LOI 2
Mar 14/2022



COMPONENT MAINTENANCE MANUAL
1756-1 and 1756-3

LIST OF TABLES

TABLE	DESCRIPTION	PAGE
1	Leading Particulars	2
1001	Initial Discharge (Off-wing Capacity)	1007
1002	Charge Table	1009
1003	Final Charge Voltage Limit	1009
1004	Capacity Test (Second Discharge)	1011
1005	Sensor Values	1012
1006	Battery Faults	1015
1007	Cell Faults	1016
1008	Physical Faults	1017
7001	Battery Spacer Kit (020)	7002
8001	Torque Values	8001
9001	Special Tools	9001
9002	Consumables	9004
15001	Return to Service Following Storage	15001
15002	Refresh Charge	15003

24-32-06

LOT 1
Mar 14/2022



COMPONENT MAINTENANCE MANUAL
1756-1 and 1756-3

PAGE INTENTIONALLY LEFT BLANK

24-32-06

LOT 2
Mar 14/2022



COMPONENT MAINTENANCE MANUAL
1756-1 and 1756-3

INTRODUCTION

1. General

- A. This manual is written to the ATA Specification 100 and in ASD Simplified Technical English. International Standard units of measure are used in this manual, with imperial units in parentheses.
- B. This manual describes maintenance on components in a workshop. It does not describe maintenance on components when they are installed in aircraft.
- C. Only approved personnel with the necessary skill can do maintenance tasks described in this manual.
- D. This manual contains:
 - (1) Technical data for components
 - (2) Maintenance and replacement procedures for components
 - (3) An Illustrated Parts List (IPL) with data for parts of components. Parts are identified in all sections of the manual by IPL figure and item number.
- E. We make sure of DISASSEMBLY, TESTING AND FAULT ISOLATION, and ASSEMBLY procedures by doing them.
The manual is divided into separate sections:
 - (1) Title Page
 - (2) Record of Revisions
 - (3) Record of Temporary Revisions
 - (4) List of Effective Pages
 - (5) Table of Contents
 - (6) Introduction
 - (7) Procedures and IPL Sections

The disassembly and assembly sections contain only specific instructions used on the equipment covered herein. Most standard aerospace practices are not described herein.

This manual provides the information necessary for an experienced shop technician to maintain Saft nickel-cadmium batteries. It describes construction of the battery, as well as techniques used to operate, maintain, and provide care for the battery. Following these instructions will enhance the ability to obtain optimum performance and maximum life from Saft batteries.

All aircraft batteries require checking and maintenance to make sure they are safe when installed and they perform their required functions especially in emergency conditions on board the aircraft. Maintenance allows problems to be identified and corrected. The maintenance interval is the period for which correct operation is assured with a low probability of failure and allows elevated levels of MTBUR and MTBF.

Every effort has been made to provide complete and accurate instructions. If a situation should arise that is not adequately described in this manual, please contact Saft via the internet at www.saft.com or at one of the following addresses:

24-32-06

Intro 1
May 15/2023



COMPONENT MAINTENANCE MANUAL
1756-1 and 1756-3

Saft America Inc. (09052)
711 Gil Harbin Industrial Boulevard
Valdosta, GA 31601, USA

Phone: +1 (229) 247-2331
Fax: +1 (229) 247-8486

Saft (F6177)
126 quai Charles Pasqua
92300 Levallois-Perret, France

Phone: +33 1 58 63 16 00
Fax: +33 1 58 63 16 18

2. Definitions

Warnings call attention to use of materials, procedures, or limits which must be followed precisely to avoid injury to persons.

Cautions call attention to procedures which should be followed to avoid damage to equipment.

Notes call attention to procedures which make the job easier.

3. Safety

WARNING: EXCEPT FOR THOSE STEPS THAT REQUIRE THE BATTERY TO BE CHARGED, DO ALL STEPS ON DISCHARGED BATTERIES (REFER TO [INITIAL DISCHARGE](#) AND [CELL SHORTING](#)) TO AVOID THE POSSIBILITY OF ELECTRIC SHOCK. FINGER TIGHTEN VENT VALVES (230) WITH [T01](#) PRIOR TO BEGINNING DISCHARGE. BATTERY CELLS DELIVER VERY HIGH CURRENT WHEN SHORT-CIRCUITED. EXERCISE CAUTION. REMOVE RINGS, WATCHES, NECKLACES, METALLIC BELTS AND OTHER JEWELRY TO AVOID ELECTRIC SHOCK.

WARNING: CARE SHOULD BE TAKEN TO NOT OVER TIGHTEN THE VENT VALVES (230) AS STRIPPED THREADS ON EITHER THE VALVE OR CELL COVER MAY ALLOW ELECTROLYTE LEAKAGE WHILE ON THE AIRCRAFT RESULTING IN UNSCHEDULED REMOVALS.

WARNING: DO NOT TILT THE BATTERY DURING MAINTENANCE, ANY CONTACT OF SKIN WITH ELECTROLYTE CAN CAUSE SEVERE BURNS.

Safety rules are different from one country to another. Always follow local safety regulations.

There are three types of risks

A. Physical

- (1) Handling: the battery is heavy. When you lift it, bend your legs and not your back.
- (2) Use protective shoes.

B. Electrical

- (1) Do not wear rings, watches, chains, belt buckles, necklaces, or any other metallic objects.
- (2) Use insulated tools.

C. Chemical

- (1) For a complete listing of hazards, refer to the safety information sheet available on Saft's website at www.saft.com.
- (2) Electrolyte is very corrosive and can damage the skin: use gloves and an apron. If it touches the skin, flush affected part with large quantity of water. Remove contaminated clothing, after flushing begins.

24-32-06

Intro 2
May 15/2023



COMPONENT MAINTENANCE MANUAL
1756-1 and 1756-3

- (3) Electrolyte is very dangerous for eyes, use protective goggles. If the electrolyte comes in contact with an eye, flush it with water and get immediate medical attention.
- (4) Saft recommends the use of an amphoteric solution (both acidic and basic behavior) and chelator (able to trap cations as a chelate complex) to neutralize electrolyte according to the local regulation.
- (5) Electrolyte ingestion can cause damage to the throat and respiratory tract. Do not try to vomit and get immediate medical attention.
- (6) Skin contact with nickel can cause chronic eczema.
- (7) Inhalation of cadmium oxide can cause dry throat, headaches, vomiting, chest pain. If inhaled, move to fresh air. If not breathing, give artificial respiration. If breathing is difficult, give oxygen and get immediate medical attention.

4. New Battery Commissioning

Saft batteries are shipped discharged. All new Saft batteries receiving an initial commissioning within 12 months of the DOM refer to [Initial New Battery Commissioning](#) on page [5001](#) to place into service.

For all new Saft batteries that have not received an initial commissioning within 12 months of the DOM, then refer to [Servicing at end of long-term storage](#), [Table 15001](#).

5. Battery Ratings

A. Capacity

Nickel-cadmium batteries are rated in terms of capacity in ampere-hours (Ah) (rated capacity).

Other definitions for battery ratings can be found in EN2570, IEC 60952, and RTCA DO 293.

6. Recycling

All batteries eventually lose their ability to perform and are eligible for scrapping and recycling. Saft takes environmental matters seriously and advocates proper recycling of nickel-cadmium batteries and their components. To that end, Saft operates recycling facilities in both Europe and North America.

Nickel-cadmium batteries contain nickel, cadmium, and potassium hydroxide and should be disposed of properly. In all cases, rely on local and national regulations for proper battery disposal and/or shipping to an appropriate recycling location.



Universal Recycling Symbols
Figure Intro 1

You can find the nearest recycling collection point on our website at www.saft.com.

7. End of Life

EASA and FAA regulations “Part 145” requires end of life cells to be disposed of in a manner prohibiting them to be returned to service. Other authorities may have requirements less explicit, Saft recommends the following procedure to be followed to provide a means of compliance.

- A. Make sure the appropriate protective measures (refer to [Safety](#) paragraph and Battery Information Sheet (BIS)) are taken.
- B. Make sure the cell is fully discharged (See [Cell shorting](#)).
- C. Put one of the terminals from the cell into a bench vice and bend the terminal until it breaks. If any electrolyte leakage occurs, make sure the cleaning procedures are correctly applied (see Battery Information Sheet (BIS)).
- D. Dispose of the cell in accordance with applicable transport, health and safety, and recycling regulations. (Refer to [Recycling](#) paragraph)

All batteries eventually lose their ability to perform and are eligible for scrapping and recycling. Saft takes environmental matters seriously and advocates proper recycling of nickel-cadmium batteries and their components. To that end, Saft operates recycling facilities in both Europe and North America

8. Abbreviations

A	Amperes
ASD	AeroSpace and Defence Industries Association of Europe
ATA	Air Transport Association of America
EASA	European Air Safety Authority
FAA	Federal Aviation Authority
IATA	International Transport Air Association
IEC	International Electrotechnical Commission
IMDG	International Maritime Dangerous Goods
IPL	Illustrated Parts List
MTBF	Mean Time Between Failure
MTBUR	Mean Time Between Unscheduled Removal
P/N	Part Number
RTCA	Radio Technical Commission for Aeronautics
V	Voltage



COMPONENT MAINTENANCE MANUAL
1756-1 and 1756-3

DESCRIPTION AND OPERATION

1. Description

The Saft alkaline battery has 20 semi-open, nickel-cadmium VP170KH cells with welded polyamide cases housed in a stainless-steel box. The case is lined with thin sheets of insulation. The cells are kept upright by means of molded silicon elastomer part fastened to the case cover that presses against the top of the cells. Cells are interconnected by rigid nickel-plated copper links. End cells are connected by output connections to a battery power connector. Each sensor harness contains a thermal resistor and battery midpoint voltage point lug.

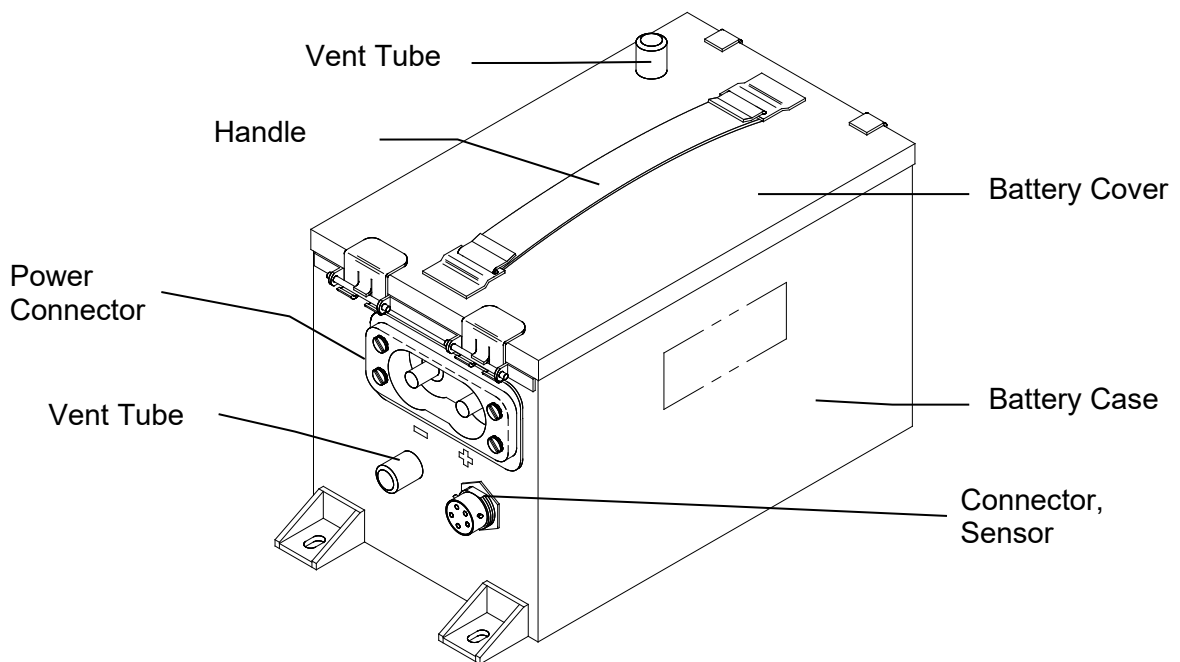

Nickel Cadmium Battery
Figure 1



COMPONENT MAINTENANCE MANUAL
1756-1 and 1756-3

PARAMETER	VALUES
Nominal Voltage	24.0 Volts
Weight	18.1 kg (40 pounds)
Dimensions (Maximum): Height Length Width	199.9 mm (7.87 inches) 322.6 mm (12.70 inches) 163.1 mm (6.42 inches)
Number of Cell Assemblies	20
Connector	MS 18093
Cell Model	Saft-Type VP170KH
1.0C ₁ A Rate	17.0 Ampere
0.5C ₁ A Rate	8.5A
0.1C ₁ A Rate	1.7A
Rated Capacity (C ₁)	17 Ampere-hours at 1.0C ₁ A
Vent valve	M8 X 1.00 thread
Cell Consumable Reserve	20 cm ³ (1.22 in ³)
Venting Pressure	0.14 to 0.69 bar (2 to 10 psi)
Cell Case Material	Polyamide
Battery Case Material	Stainless Steel
Electrolyte	Potassium Hydroxide
Operation temperature	-40°C to +71°C (-40°F to +160°F)
Ambient temperature	+15°C to +30°C (59°F to 86°F)

Leading Particulars
Table 1

2. Operation

A. Flight charging

The battery is charged on the aircraft by an on-board charger. The charge control thermistor supplies a signal to the charger to compensate the charge according to the battery temperature.



COMPONENT MAINTENANCE MANUAL
1756-1 and 1756-3

B. Maintenance

(1) Maintenance interval basis

The aircraft manufacturer is responsible for the definition of usage and function, including maintenance interval, for batteries installed in its aircraft. The maintenance interval has two main factors:

- Energy available for emergency requirements
- Electrolyte consumable reserve.

Both depend on the battery charging system, battery operating temperature, type of starting, number of starts, flight duration, ground operation, and battery technology. These affect the ratio of capacity charged / capacity discharged and capacity overcharged.

The higher voltage per cell that is applied, the higher overcharge current and capacity the battery receives.

The overcharged capacity is directly related to the electrolysis of water from the electrolyte, and hence the consumption of the electrolyte reserve. For every 3 Ah of overcharge, 1 cc (0.061 in³) of water is consumed via electrolysis. Once the water reserve has been consumed, the result is:

- Dried out cells with a significant risk of permanent damage
- Internal short circuit
- Overheating
- Thermal runaway.

(2) Maintenance interval extensions

To validate maintenance interval extension, the recommendation is the Operator and Saft review the maintenance records for a minimum period of 12 months.

The data includes but is not limited to the recording of aircraft flight hours when the battery was installed, removal date, inspection date, off-wing capacity, and water consumption as required by this CMM.

As with any maintenance extension, continuous monitoring of the water addition and electrical performance upon removal from the aircraft must be performed to detect any adverse effects and, if necessary, re-adjust the maintenance interval accordingly. To determine the electrical performance more readily after aircraft removal, the battery may be floated 31V for 1.5 hours if the aircraft uses a dedicated charger or 28.5V for 1.5 hours if it floats on the aircraft bus before performing the Initial discharge (off-wing capacity) test.



COMPONENT MAINTENANCE MANUAL
1756-1 and 1756-3

C. Battery data requirements

Maintenance information is required for any Saft battery evaluation to determine its condition and health. Throughout this manual there are multiple steps requiring specific information be recorded to maintain a battery service history. The information provided not will only reflect the batteries airworthiness, but also provide information to assist in any battery issue investigations required at the factory. As a minimum the items identified below are required for each battery maintenance step/action.

- (1) Record the date the battery was received, and time testing started.
- (2) As required for all discharges, record the duration the first cell reaches 1.0V.
- (3) As required during charges,
 - (a) Record the cell voltages at the start of the charge, at the end of the main charge, and the last 30 minutes of the final charge.
 - (b) Record the water added to each cell during the last 30 minutes of the final charge.
- (4) As required for special testing, record location and reason for cell replacement either voltage or capacity.
- (5) Record the date the battery is returned to service.



COMPONENT MAINTENANCE MANUAL
1756-1 and 1756-3

TESTING AND FAULT ISOLATION

1. General

This section has battery functional tests and fault isolation information. Test procedures are written in step-by-step formats that follow the process flow outlined in [Figure 1001](#), [Figure 1002](#), or [Figure 1003](#). Fault isolation is provided in chart form to identify faults, possible causes, and remedies, refer [Table 1006](#), [Table 1007](#), and [Table 1008](#).

NOTE: The () part identification numbers herein are [IPL Figure 1](#) item numbers.

NOTE: All voltage readings are DC unless specifically otherwise stated.

2. Required Test Equipment

NOTE: Test equipment having equivalent specifications can be used.

Refer to [Special Tools, Fixtures, Equipment, and Consumables](#) for listing of Standard Tools.

3. Maintenance Procedures

In addition to the checks specified for airborne or ground use, in normal service SAFT 1756-1 and 1756-3 batteries require the following maintenance operations.

NOTE: Unless the maintenance has been previously increased or the air manufacturer states a different value, the following are provided as guidelines.

NOTE: These periods are given as an indication; modify in accordance with operational experience.

NOTE: Periodical and Regular Check may be combined if operating hours do not meet times listed.

A. Periodical check

If the electrolyte consumption exceeds the maximum consumable amount between two Regular Checks, this Periodical Check per [Figure 1001](#) may be done to adjust the electrolyte and prevent damage to the cells.

B. Regular check

Perform [Figure 1002](#) according to the aircraft manufacture or operator maintenance requirements. If these are not available, then it is recommended to perform this check every six months.

C. General overhaul

Perform [Figure 1003](#) according to the aircraft manufacture or operator maintenance requirements or when required by [Figure 1001](#) or [Figure 1002](#).

COMPONENT MAINTENANCE MANUAL 1756-1 and 1756-3

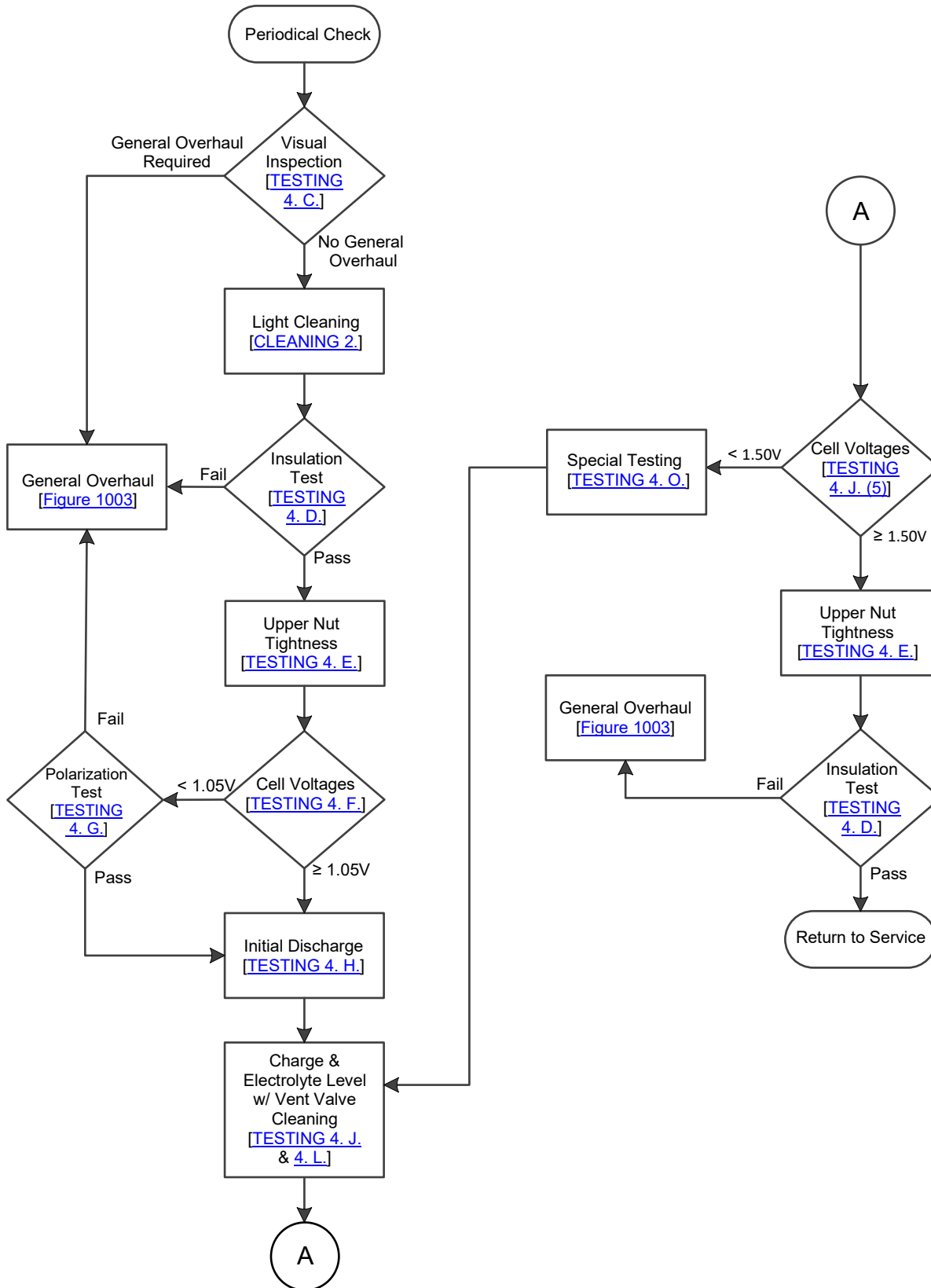

Periodical Check
Figure 1001

24-32-06

COMPONENT MAINTENANCE MANUAL 1756-1 and 1756-3

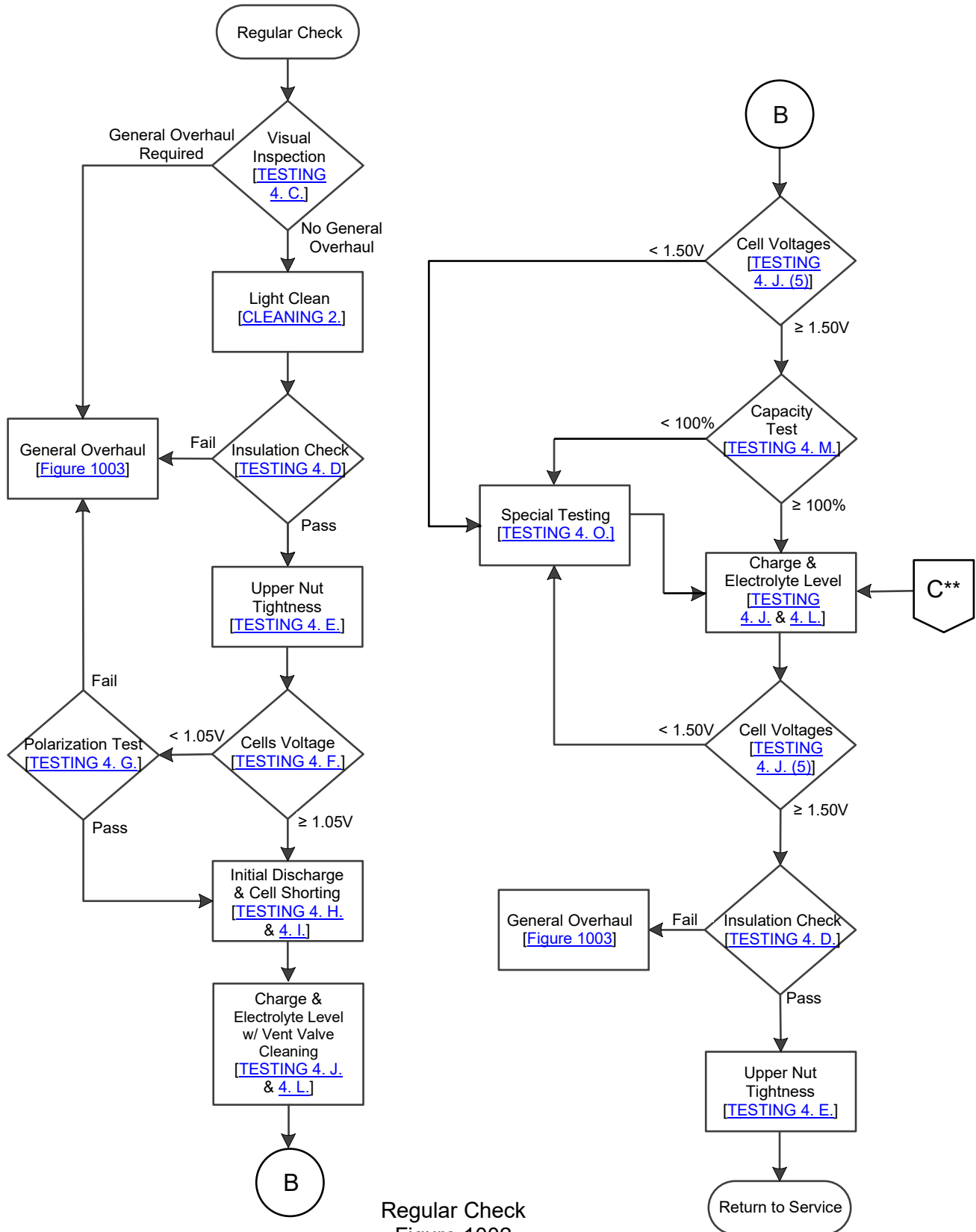

Regular Check
Figure 1002

** From [Table 15001](#)

24-32-06

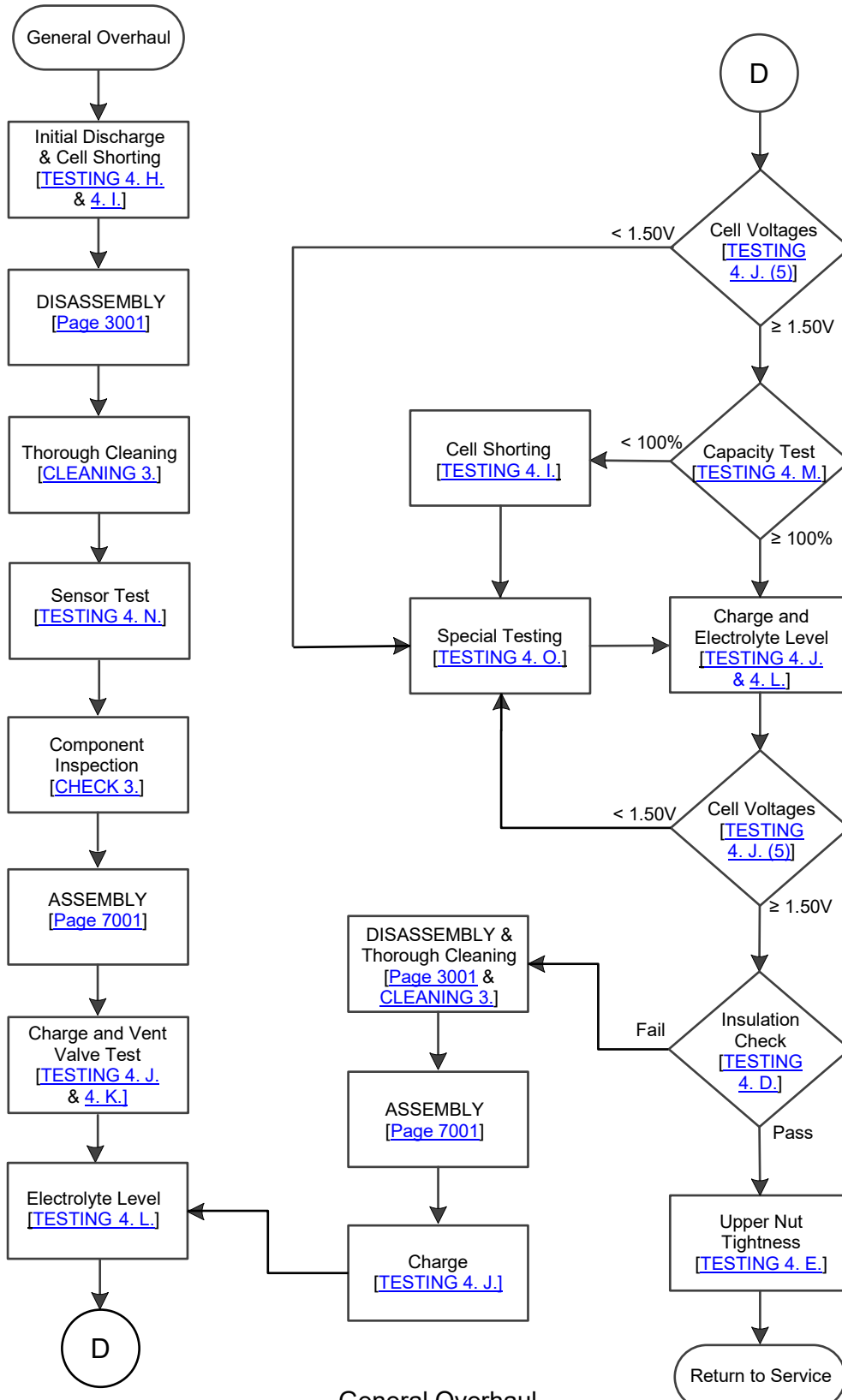

General Overhaul
Figure 1003



COMPONENT MAINTENANCE MANUAL
1756-1 and 1756-3

4. Testing

A. Test conditions

(1) Facilities and equipment

CAUTION: FUMES FROM LEAD ACID BATTERIES OR SMALL TRACES OF SULFURIC ACID ENTERING A NI-CD BATTERY CAN CAUSE PERMANENT DAMAGE.

(a) Service facilities for Ni-Cd batteries must be entirely separate from those for lead acid batteries.

(b) Equipment used to service lead acid batteries must not be used to maintain Ni-Cd batteries.

(2) For optimum results conduct all tests with the battery temperature at ambient temperature, unless otherwise noted in this manual.

B. Test equipment

Refer to [Special Tools, Fixtures, and Equipment, and Consumables](#) for test equipment recommendations.

C. Visually inspection

Items found may require doing a general overhaul immediately while the majority do not. If a finding does not require doing to the general overhaul procedure, then specific instructions are provided on how and when the item will be corrected.

(1) Visually inspect battery cover ([030](#)) for dents, distortion, or other damage and replace with new Saft cover ([030](#)), as necessary.

(2) Visually inspect battery case ([010](#) or [010A](#)) for dents, distortion, or other damage. If found, identify case for replacement.

(3) Visually inspect visible portions of each cell ([220](#)) for any evidence of electrolyte leakage and damage.

(a) Damaged cells ([220](#)) should be marked for replacement or further cleaning.

NOTE: Excessive electrolyte leakage will cause the battery to fail the Battery insulation test.

(b) Excessive salts around the terminal posts gives an indication of possible leakage from terminal O-ring ([290](#)). Identify any cells with excessive salts for later torquing the lower nut ([250](#)).

(c) When inspection reveals electrolyte leakage from the cell at the vent hole opening, replace the defective O-ring ([240](#)).

WARNING: USE CARE NOT TO TILT CELLS WHILE VENT VALVES ARE OPEN OR REMOVED; CONTACT OF ELECTROLYTE WITH CAN CAUSE SEVERE BURNS.

1. Using the [T01](#) loosen and remove the vent valve ([230](#)) from the cell ([220](#)).

2. Remove and replace the defective O-rings ([240](#)) from the vent valve ([230](#)).

24-32-06

1005

May 15/2023



COMPONENT MAINTENANCE MANUAL
1756-1 and 1756-3

CAUTION: CARE SHOULD BE TAKEN TO NOT OVER TIGHTEN THE VENT VALVES (230) AS STRIPPED THREADS ON EITHER THE VALVE OR CELL COVER MAY ALLOW CONTAINMENTS TO ENTER THE CELL (220). ANY STRIPPED THREADS REQUIRE COMPONENT REPLACEMENT.

3. Using T01, finger tighten vent valve (230) onto cells (220) securely in place.
 - (4) Inspect the upper nuts (070), (140), washers (080), (150), and links (090 through 130) to ensure it is free of bends, tarnish, corrosion, burns, or loss of plating. Minor tarnish can be polished off with a fine wire brush. Identify defective hardware for later replacement.
 - (5) Check all ventilation openings to make sure that they are clean and clear.
 - (6) Inspect the power connector (040) and its pins for defects, evidence of arcing or excessive oxidization. If observed, identify the power connector (040) for later replacement.
- D. Battery insulation
- NOTE:** A breakdown in electrical insulation between the cells and the battery case will result in a "leakage" current, which, over a period of time, can discharge the battery.
- (1) On a completely assembled battery using a megohmmeter under a continuous 250V, measure the insulation resistance between the metal box and
 - (a) the positive terminal of each cell,
 - (b) the power connector positive pin, and
 - (c) each pin of the sensor connector.
 - (2) The value measured must be $\geq 10\text{M}\Omega$ under a continuous 250V.
 - (3) If the reading meets the above criteria ($\geq 10\text{M}\Omega$), the insulation is a "Pass"; otherwise, the insulation test is a "Fail".
- NOTE:** If, after cleaning the battery and assuring that everything is dry, a leakage current is still $< 10\text{M}\Omega$, then one or more cells (220) is defective. Isolate and identify for later replacement.
- E. Upper nut tightness
Check the tightness on each upper terminal nut (140), (070) per [Table 8001](#).
- F. Cell voltage
Measure and verify the voltage of each cell (220) is greater than or equal to 1.05V.
- G. Polarization test
- (1) Charge the battery at $0.1C_1$ for 1.5 hours.
 - (2) Keep the battery in open circuit for 1 hour.
 - (3) Measure the open circuit voltage of each cell (220).
 - (a) Mark for replacement each cell (220) with zero volts or negative polarity. If any cell (220) is marked for replacement, the polarization test is a "Fail".
 - (b) If all cells (220) are above zero volts, the polarization test is a "Pass".



COMPONENT MAINTENANCE MANUAL
1756-1 and 1756-3

H. Initial discharge (off-wing capacity)

The purpose of this procedure is to discharge the battery to a known state of charge and determine the battery capacity from the aircraft.

CAUTION: CARE SHOULD BE TAKEN TO NOT OVER TIGHTEN THE VENT VALVES (230) AS STRIPPED THREADS ON EITHER THE VALVE OR CELL COVER MAY ALLOW CONTAINMENTS TO ENTER THE CELL (220). ANY STRIPPED THREADS REQUIRE COMPONENT REPLACEMENT.

- (1) Using T01, verify the vent valve (230) is finger tight on each cell (220).
- (2) Discharge the battery at the rate shown in Table 1001 until the battery reaches 20.0V and record the times the first cell reaches 1.0V and battery reaches 20.0V.

NOTE: It is important that the discharge current be continually kept at the selected value, and that the time of discharge be measured accurately.

NOTE: If a cell goes to zero volts or reverses polarity during the discharge, short out the cell's terminals for the rest of the discharge.

DISCHARGE		MINIMUM TIME FOR DISCHARGE TO 20.0V
RATE (C ₁)	CURRENT (AMPS)	
1.0	17.0	30.0 MINUTES

Initial Discharge (Off-wing Capacity)
Table 1001

- (a) The minimum discharge time to 20.0V should per Table 1001. If not, one of the following may be the cause.
 1. The battery was discharged since the last aircraft charge.
 2. The aircraft charger may not be functioning properly.
 3. If the battery was left idle for a time and self-discharge occurred.
 4. The battery cells may be imbalanced and need servicing.
- (3) If defective case (010 or 010A), power connector (040), nuts (070), (140) and washers (080), (150), or links (090 to 130) were found during visual inspection, they are to be corrected by performing appropriate **DISASSEMBLY** and **ASSEMBLY**.
- (4) For each cell (220) marked for replacement, do **Cell replacement** in **REPAIR**.
- (5) For each cell (220) which have excessive salts around the terminals during visual inspection, do **Lower nut tightness**.
- (6) For cell hardware (250), (260) or (260A), (270), (280), or O-ring (290) requiring replacement, do **Cell hardware replacement** in **REPAIR**.
- (7) For terminal O-ring (290) requiring replacement, do **Terminal O-ring replacement** in **REPAIR**.



COMPONENT MAINTENANCE MANUAL
1756-1 and 1756-3

I. Cell shorting

CAUTION: CARE SHOULD BE TAKEN TO NOT OVER TIGHTEN THE VENT VALVES (230) AS STRIPPED THREADS ON EITHER THE VALVE OR CELL COVER MAY ALLOW CONTAINMENTS TO ENTER THE CELL (220). ANY STRIPPED THREADS REQUIRE COMPONENT REPLACEMENT.

- (1) Using T01, verify the vent valve (230) is finger tight on each cell (220).
- (2) Discharge each cell in the battery to zero volts using one of two methods below:
NOTE: It is not necessary to have a rest period between discharge and cell shorting.
 - (a) Method A
 1. Continue to discharge the battery per Table 1001 until each cell reaches 1.0V, connect a T03 across its terminals. After all the cells have been shorted, leave the devices in place for 12 to 24 hours.
 - (b) Method B
 1. Continue to discharge the battery per Table 1001 until each cell is < 0.5V, then connect a shorting clip across its terminals. After all the cells have been shorted, leave the devices in place for 16 to 24 hours.
- (3) At completion of Method A or B, remove the shorting devices.
- (4) If no cells (220) were marked for replacement, return to Figure 1002 or Figure 1003.
- (5) If any cell (220) was marked for replacement, do Cell replacement in REPAIR.

J. Charge

- (1) Allow the battery to cool to ambient temperature.
- (2) Remove the cover (030),
- (3) Prior to charging the battery, loosen (do not remove) all vent valves (230). Ensure that the shorting spring has been removed.
NOTE: If required by Figure 1003 or yearly testing, it is recommended to do Vent valve test during this charge.
- (4) Charge the battery using one of the three methods in Table 1002.
 - (a) Record the cell voltages at the start and end of the main charge (Step 1), and then the last 30 minutes of the final charge (Step 2).
 1. If the start cell voltage of the main charge (Step 1) goes above 1.50V, add to the cell about 5 cm³ (0.31 in³) of M01.
 2. During the last 30 minutes of the final charge (Step 2), adjust the Electrolyte level and check for Minimum final charge voltage.



COMPONENT MAINTENANCE MANUAL
1756-1 and 1756-3

CHARGE TABLE			
MAIN CHARGE (STEP 1)			FINAL CHARGE (STEP 2)**
Current	Minimum Time*	End of Main Charge Criteria	Current and Time
0.1C ₁ A (1.7A)	10h	Every cell >1.5V or 12h whichever comes first	0.1C ₁ A (1.7A) for 4h
0.5C ₁ A (8.5A)	2h	Every cell >1.55V or 2.5h whichever comes first	0.1C ₁ A (1.7A) for 4h
1.0C ₁ A (17.0A)	1h	Every cell >1.57V or 1.25h whichever comes first	0.1C ₁ A (1.7A) for 4h

* Minimum time applies to a battery previously discharge to 20.0V.

** During the last 30 minutes do [Electrolyte level](#) and confirm minimum voltage criteria in [Table 1003](#).

Charge Table
Table 1002

(5) Minimum final charge voltage

During the last 30 minutes of the final charge (Step 2) measure and verify the voltage of each cell ([220](#)) meets the value shown in [Table 1003](#). Identify each cell that does not comply.

CELL VOLTAGE Last 30 minutes at 0.1C ₁ A
≥ 1.50V

Final Charge Voltage Limit
Table 1003

K. Vent valve test

CAUTION: THE CELL OPENINGS MUST BE COVERED WITH A CLEAN DAMP CLOTH TO PREVENT ENTRY OF FOREIGN MATTER.

NOTE: This test is not necessary if all the vent valves are replaced with Saft new valves each year or applicable maintenance interval.

NOTE: It is recommended to do this test while the battery is on charge.

(1) Check the operation of the vent valve ([230](#)) as follows:

- Use [T01](#), finger tighten the vent valve ([230](#)) that contains O-ring ([240](#)) onto [T05](#) fixture.
- Attach the fixture [T05](#) to a compressed air line through an adjustable pressure reducing valve limited to 1.38 bar (20 psi).
- Slowly raise the air pressure to 1.38 bar (20 psi) maximum to test the functionally below.
- Immerse the valve and end of fixture in water, and slowly raise the pressure. Make sure the valve opens between 0.14 to 0.69 bar (2 to 10 psi).

COMPONENT MAINTENANCE MANUAL 1756-1 and 1756-3

- (e) Reuse only those vent valves found to open in the 0.14 to 0.69 bar (2 psi and 10 psi) range. Re-soak vent valves that do not open at 0.69 bar (10 psi) until they do open (refer to [CLEANING](#) on page [4001](#)). Discard vent relief valves which are not gas tight at low pressure.

L. Electrolyte level

This procedure is to be carried out during the last 30 minutes of the final charge (Step 2) at 0.1C₁A.

WARNING: USE CARE NOT TO TILT CELLS WHILE VENT VALVES ARE LOOSENED OR REMOVED; CONTACT OF ELECTROLYTE WITH SKIN CAN CAUSE SEVERE BURNS.

CAUTION: USING ANYTHING OTHER THAN [M01](#) IN NICKEL-CADMIUM CELLS WILL CAUSE ELECTROLYTE CONTAMINATION AND DAMAGE. DO NOT RE-USE WATER REMOVED FROM CELLS.

- (1) Remove the vent valves ([230](#)) with the [T01](#), taking precautions to prevent foreign substances from entering the cell ([220](#)).
 - (a) Clean vent valves ([230](#)) by immersing the valves and their O-rings ([240](#)) in [M01](#) and let them soak to dissolve any salts.
- (2) Insert [T02](#) into the cell opening until the shoulder of the nozzle rests on the valve seat (refer [Figure 1004](#)).

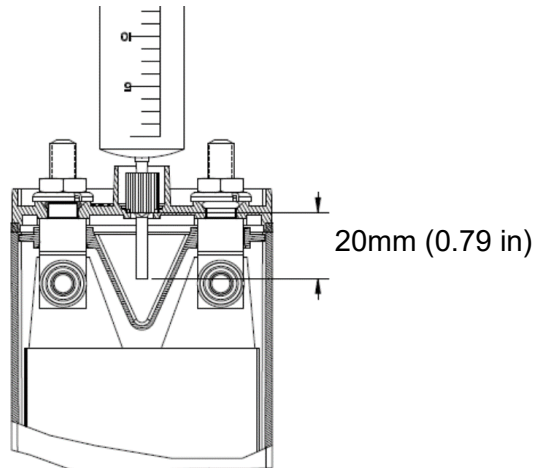

Position of [T02](#) in Cell Vent Seat

Figure 1004

- (3) Withdraw the plunger and check for any liquid in [T02](#).
 - (a) Any excess liquid in the cell will be drawn into the syringe until the electrolyte level is correct.
 - (b) If the liquid level is too low, the syringe will remain empty, indicating that the end of the syringe nozzle did not reach the liquid in the cell.

NOTE: If the quantity of water added per cell exceeds 20 cm³ (1.22 in³), then check the charging system. If the aircraft charging system is functioning properly, the maintenance period may need to be reduced.



COMPONENT MAINTENANCE MANUAL
1756-1 and 1756-3

1. Draw a measured amount of the [M01](#), such as 5 cm³ (0.31 in³) into the syringe and inject it into the cell.
2. With the syringe nozzle resting on the valve seat, slowly withdraw the plunger into [T02](#).
3. If [T02](#) remains empty, repeat steps 1 and 2, above. counting the total number of cm³ added to achieve the correct level.
4. At the point in step 2 when some excess liquid is drawn into the [T02](#), the correct level for that cell has been reached. Expel the excess liquid into a separate container for proper disposal of hazardous waste.
5. Record the amount of water added/removed from each cell in the battery logbook or battery test sheet.

WARNING: CARE SHOULD BE TAKEN TO NOT OVER TIGHTEN THE VENT VALVES ([230](#)) AS STRIPPED THREADS ON EITHER THE VALVE OR CELL COVER MAY ALLOW ELECTROLYTE LEAKAGE WHILE ON THE AIRCRAFT RESULTING IN UNSCHEDULED REMOVALS.

- (4) Using [T01](#), finger tighten the vent valve ([230](#)) on each cell ([220](#)).

M. Capacity test (second discharge)

The purpose of this discharge procedure is to verify minimum battery capacity.

- (1) Prior to doing the capacity test, do [Charge](#) and [Electrolyte level](#).

CAUTION: CARE SHOULD BE TAKEN TO NOT OVER TIGHTEN THE VENT VALVES ([230](#)) AS STRIPPED THREADS ON EITHER THE VALVE OR CELL COVER MAY ALLOW CONTAINMENTS TO ENTER THE CELL ([220](#)). ANY STRIPPED THREADS REQUIRE COMPONENT REPLACEMENT.

- (2) Using [T01](#), verify the vent valve ([230](#)) is finger tight on each cell ([220](#)).
- (3) Discharge the battery at one of the current rates shown in [Table 1004](#) until the battery reaches 20.0V to determine and record the times the first cell reaches 1.0V and battery reaches 20.0V.

NOTE: It is important that the discharge current be continually kept at the selected value, and that the time of discharge is measured accurately.

NOTE: If a cell goes to zero volts or reverses polarity during the discharge, short out that cell's terminals with a [T03](#) for the remainder of the discharge.

DISCHARGE		MINIMUM TIME FOR FIRST CELL TO 1.0V
RATE (C ₁)	CURRENT (AMPS)	
1.0	17.0	60 MINUTES

Capacity Test (Second Discharge)
Table 1004

- (4) If the time until the first cell reaches 1.0V equals or exceeds the values shown in [Table 1004](#) at the discharge rate the capacity is ≥ 100%, allow the battery to rest at least 2 hours.
- (5) If the time the first cell reached is less than the minimum time shown in [Table 1004](#) at the discharge rate, the capacity is < 100%.

N. Sensor harness test

WARNING: A FULLY ASSEMBLED BATTERY MUST BE IN A FULLY DISCHARGED CHARGE STATE TO PREVENT INJURY, REFER TO [CELL SHORTING](#).

- (1) If any part of the sensor harness ([160](#) or [160A](#)) is damaged, the entire assembly must be replaced by performing [DISASSEMBLY](#) and [ASSEMBLY](#).

NOTE: A climate chamber or alternate methods may be used provided the temperatures below are achieved.

NOTE: Refer to [Figure 1005](#) for pinout locations.

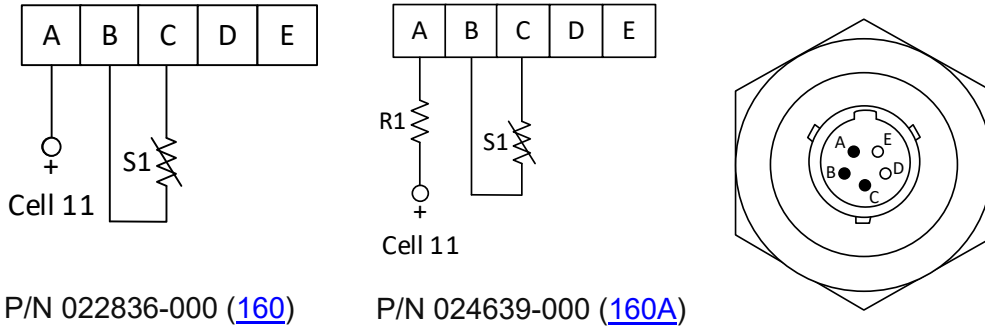

P/N 022836-000 ([160](#))

P/N 024639-000 ([160A](#))

Connector Pinout
Figure 1005

- (2) Sensor harness ([160](#) or [160A](#))

Verify the sensor values at the temperatures as required by [Table 1005](#). Any erratic readings represent a failure and replace with new Saft sensor harness ([160](#) or [160A](#)).

SENSOR P/N	BATTERY TYPE	PINS	VALUES @ +25 ± 10°C (+77 ± 18°F)
022836-000	1756-1	Lug and Pin A	0Ω
		pins B and C	3000Ω ± 180Ω
024639-000	1756-3	Lug and Pin A	4990Ω ± 1%
		pins B and C	3000Ω ± 180Ω

Sensor Values
Table 1005

O. Special testing

These procedures are to be followed for a battery that does not meet capacity or if the end of charge cell voltage was < 1.50V during the final charge. Refer to [Figure 1006](#) flow chart.

NOTE: For a new battery or one removed from the aircraft that has not passed capacity after doing the special testing more than 3 times, it is recommended to replace noncompliant cells with new Saft cells ([220](#)), refer to [All cell replacement](#) recommendation in [REPAIR](#).

NOTE: For battery from long-term storage, several complete charge/discharge cycles may be needed to restore performance.



COMPONENT MAINTENANCE MANUAL
1756-1 and 1756-3

- (1) Special testing decision
For a battery with < 100% capacity, do [Low capacity \(Special testing\)](#). Otherwise for a battery with any cell voltage < 1.50V, do [Supplementary test](#).
- (2) Low capacity (Special testing)
 - (a) Loosen, but do not remove, all vent valves ([230](#)) and fully charge the battery as outlined in [Charge](#) section.
 - (b) For a battery containing any cell with voltage < 1.50V during the final charge, do [Supplementary test](#). Otherwise, do [Capacity test \(Special testing\)](#).
- (3) Supplementary test
 - (a) Charge at 0.1C₁A for an additional 5 hours and monitor the voltage of the individual cells every 30 minutes.
NOTE: The additional 0.1C₁A 5-hour charge may be stopped once all the cells are ≥ 1.50V.
 1. Identify for replacement any cell ([220](#)) with voltage < 1.50V.
 2. During the last 30 minutes of this charge, adjust the [Electrolyte level](#).
 3. Do [Cell replacement](#) in [REPAIR](#) for cells marked for replacement. Otherwise do [Capacity test \(Special testing\)](#).
- (4) Capacity test (Special testing)
CAUTION: CARE SHOULD BE TAKEN TO NOT OVER TIGHTEN THE VENT VALVES ([230](#)) AS STRIPPED THREADS ON EITHER THE VALVE OR CELL COVER MAY ALLOW CONTAINMENTS TO ENTER THE CELL ([220](#)). ANY STRIPPED THREADS REQUIRE COMPONENT REPLACEMENT.
 - (a) Using [T01](#), finger tighten the vent valve ([230](#)) on each cell ([220](#)).
 - (b) Discharge the battery at a rate shown in [Table 1004](#) until the battery reaches 20.0V. Record the time and current the battery reached 20.0V and identify noncompliant cells with voltages < 1.0V.
 - (c) If the time the first cell reaches 1.0V equals or exceeds the values shown in [Table 1004](#) at the applicable discharge rate, return to [Figure 1001](#), [Figure 1002](#) or [Figure 1003](#). Otherwise, repeat [Low capacity \(Special testing\)](#) or refer to [Fault Isolation](#).
 1. For noncompliant cells that have failed this capacity test 3 times, replace with new Saft cells ([220](#)), refer to [Cell replacement](#) in [REPAIR](#).

COMPONENT MAINTENANCE MANUAL 1756-1 and 1756-3

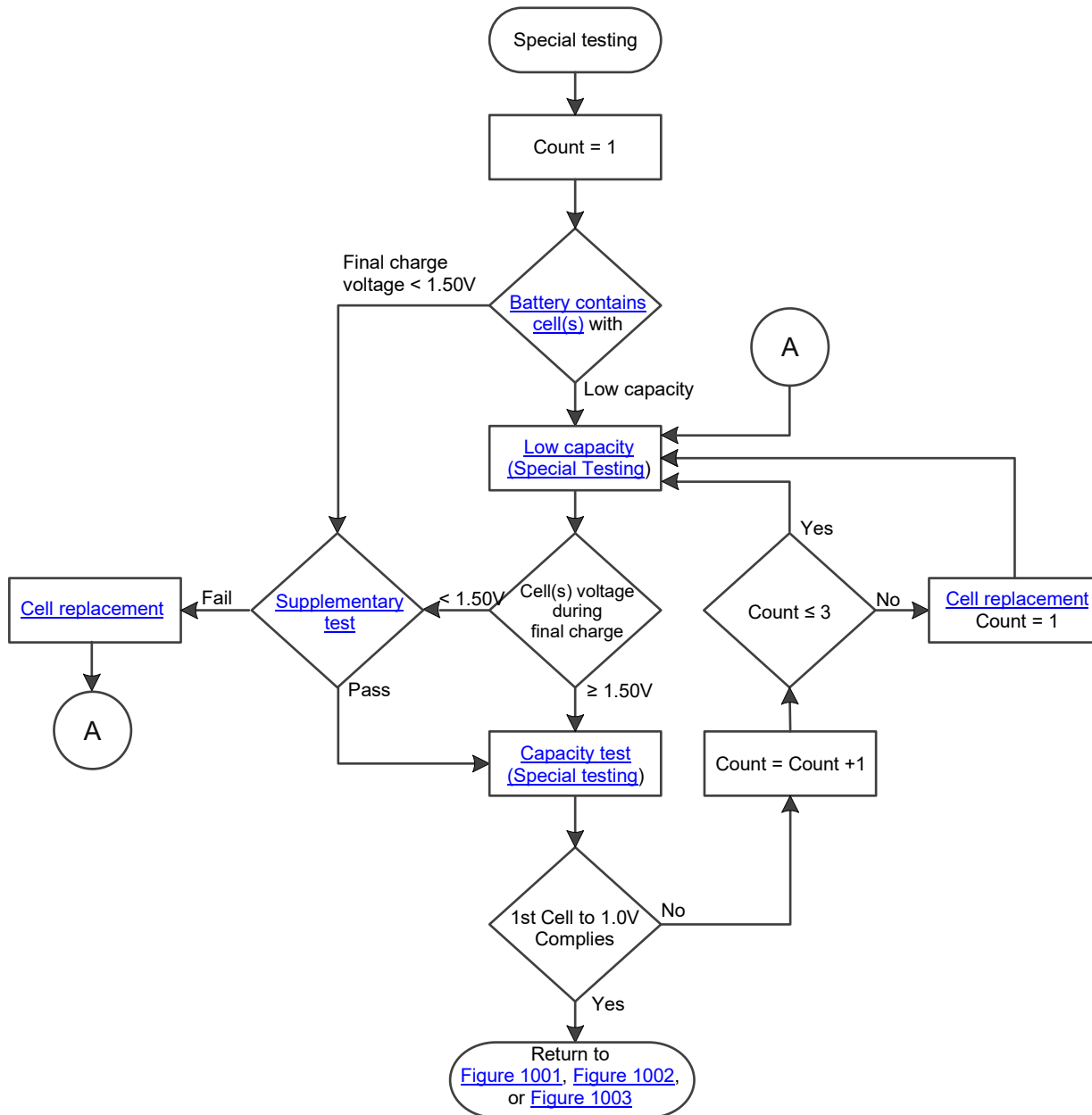

Special Testing Flow Chart
Figure 1006

P. Lower nut tightness

- (1) Remove necessary nuts (070), (140), washers (080), (150), and links (090 to 130). Torque the lower nut (250) per Table 8001.
- (2) Install necessary links (090 to 130), washers (080), (150), and nuts (070), (140). Torque nuts (070), (140) per Table 8001.



COMPONENT MAINTENANCE MANUAL
1756-1 and 1756-3

5. Fault Isolation

Fault isolation information is presented in [Table 1006](#), [Table 1007](#), and [Table 1008](#) as a guide in locating a cause of malfunction and isolating the cause to a specific component.

TROUBLE	PROBABLE CAUSE	REMEDY
(1) No battery voltage	(a) Defective power connector (not making contact). (b) Broken or damaged links	Check electrical connections Replace if required using DISASSEMBLY and ASSEMBLY
(2) Low insulation	(a) Leakage of electrolyte (b) Incorrect electrolyte level (c) Reverse cell polarity (d) Condensation / Contamination (e) Improper cleaning (f) Loose or damage vent valve (g) Damaged cell case (h) Charge rate too high	Do Thorough Cleaning , ASSEMBLY , Charge , Electrolyte level Tighten or replace vent valve, do Thorough Cleaning , ASSEMBLY , Charge , Electrolyte level Do Thorough Cleaning , Cell replacement , ASSEMBLY , Charge , Electrolyte level Investigate the cause of the excessive charge. Do Thorough Cleaning , ASSEMBLY , Charge , Electrolyte level
(3) Loss of battery capacity	(a) Normal wear after long service (b) Exceptionally heavy use	Do Special testing up to three times

Battery Faults
Table 1006



COMPONENT MAINTENANCE MANUAL
1756-1 and 1756-3

TROUBLE	PROBABLE CAUSE	REMEDY
(1) All cells have reserve consumed	(a) Charged more than allowed or charged at high temperature. (b) Previous maintenance has not been done (c) Maintenance interval too long	Examine the cause of the excessive charge. Do Charge , Electrolyte level and be sure what for the next maintenance interval. If this continues a periodical check should be done in between the regular checks.
(2) High water consumption in one or more cells	(a) Damaged separator when the water consumption is less than 30% below the average value of added water in all cells. (b) Cell imbalance when water addition is more than 30% above the average value of added water in all cells.	Do Charge , Supplementary test . Do Thorough Cleaning , Cell replacement , ASSEMBLY , Charge , Electrolyte level
(3) Abnormally high cell voltage at beginning of charge	(a) Dry cell	Add 5 to 10 cm ³ (0.31 to 0.61 in ³) of distilled water, do Electrolyte level during final charge
(4) Zero Voltage on cell	(a) Short-circuited cell	Do Cell replacement
(5) Low cell voltage at end of charge	(a) Separator damage	Do Cell replacement
(6) Low cell capacity	(a) Normal wear from long service	Do Cell replacement
(7) Cell with a swollen case	(a) Cell operated with low electrolyte level, deterioration of separator and damaged plates	Do Cell replacement

Cell Faults
Table 1007



COMPONENT MAINTENANCE MANUAL
1756-1 and 1756-3

TROUBLE	PROBABLE CAUSE	REMEDY
(1) Tarnished or burned terminal connectors	(a) Loose terminal nuts and links	Clean and torque per Table 8001
(2) Exposed copper material on power connector pin	(a) Mechanical damage (a) Electrical arcing	Replace component using DISASSEMBLY and ASSEMBLY
(3) Melted plastic on connectors	(a) Overheat due to contact resistance	Replace component using DISASSEMBLY and ASSEMBLY
(4) Corroded links	(a) Operation in acidic atmosphere (b) Inadequate greasing (c) Mechanical damage to protective nickel-plating	Check room eliminate acid source, replace component using DISASSEMBLY and ASSEMBLY Replace component using DISASSEMBLY and ASSEMBLY Replace component using DISASSEMBLY and ASSEMBLY
(5) Battery case and cover damage with dents, deformations, and visible cracks which affect fit or impede performance.	(a) Various, transport (b) Mechanical stress, drop	Replace component using DISASSEMBLY and ASSEMBLY

Physical Faults
Table 1008



COMPONENT MAINTENANCE MANUAL
1756-1 and 1756-3

PAGE INTENTIONALLY LEFT BLANK

24-32-06

1018
Nov 1/2022



COMPONENT MAINTENANCE MANUAL
1756-1 and 1756-3

DISASSEMBLY

1. General

This section provides step-by-step instructions on disassembling the complete battery.

NOTE: The () part identification numbers herein are [IPL Figure 1](#) item numbers.

2. Detailed Instructions

WARNING: BATTERY CELL ASSEMBLIES DELIVER VERY HIGH CURRENTS WHEN SHORT-CIRCUITED. EXERCISE CAUTION. REMOVE RINGS, WATCHES OR OTHER JEWELRY FROM HANDS AND ARMS.

WARNING: BATTERY MUST BE COMPLETELY DISCHARGED BEFORE CELL ASSEMBLIES CAN BE REMOVED DUE TO POSSIBILITY OF ELECTRIC SHOCK.

WARNING: USE CARE NOT TO TILT BATTERY WHILE VENT VALVES ARE LOOSENEED; CONTACT OF ELECTROLYTE WITH SKIN CAN CAUSE SEVERE BURNS.

A. Preparation

- (1) Discharge the battery at one of the current rates shown in [Table 1004](#) until each cell reaches 1.0V.
- (2) Remove the cover ([030](#)).
- (3) Do [Cell shorting](#)

B. Cell ([220](#)) removal

- (1) Remove the nuts ([070](#)), ([140](#)) and washers ([080](#)), ([150](#)) that attach the links ([090](#) to [130](#)) to the cells ([220](#)).
- (2) Remove the links ([090](#) to [130](#)) from the cell terminals.
- (3) Using [T04](#) attach the threaded end to one of the cell terminals and pull upwards to remove cells ([220](#)) from the battery case ([010](#) or [010A](#)).

C. Disassembly of the cells ([220](#)) is restricted to replacing defective cell hardware ([250](#)), ([260](#)) or ([260A](#)), ([270](#)), ([280](#)) or terminal O-rings ([290](#)). Refer to [Component replacement](#) in [REPAIR](#).

D. Power connector ([040](#)) removal

- (1) Remove the four screws ([060](#)) from the connector.
- (2) Remove the power connector ([040](#)) with its gasket ([050](#)) from the case ([010](#) or [010A](#)).

E. Sensor harness ([160](#) or [160A](#)) removal

- (1) Cut the wire tie.
- (2) Remove the nut ([140](#)) and washer ([150](#)) that attaches the sensor on the terminal. Lift off the lug and sensor plate.
- (3) Remove the jam nut ([200](#)).
- (4) Remove the sensor connector with its gasket ([210](#)) from the case ([010](#) or [010A](#)).

F. Remove all spacers ([020](#)) from the battery case ([010](#) or [010A](#)).

24-32-06

3001
May 15/2023



COMPONENT MAINTENANCE MANUAL
1756-1 and 1756-3

PAGE INTENTIONALLY LEFT BLANK

24-32-06

3002
Mar 14/2022



COMPONENT MAINTENANCE MANUAL
1756-1 and 1756-3

CLEANING

1. General

CAUTION: DO NOT USE PETROLEUM SPIRITS, TRICHLOROETHYLENE, OR OTHER SOLVENTS FOR CLEANING THE BATTERY. USE OF THESE PRODUCTS MAY DETERIORATE THE INTEGRITY OF METAL PARTS.

NOTE: The () part identification numbers herein are [IPL Figure 1](#) item numbers.

- A. The following items are required to for the cleaning procedures (equivalent substitutes can be used):
- (1) Stiff bristled brush (nonmetallic)
 - (2) Dry compressed air source, less than 1.38 bar (20 psi)
 - (3) Safety goggles
 - (4) Lubricant, non-acid petroleum jelly, [M02](#)
 - (5) Soft, clean cloth (two required)
 - (6) Running water
 - (7) Mild Soap, [M03](#)
 - (8) Distilled or de-ionized water, [M01](#)

2. Light Cleaning

A. The following procedures are for an assembled battery with cover ([030](#)), removed.

CAUTION: CARE SHOULD BE TAKEN TO NOT OVER TIGHTEN THE VENT VALVES ([230](#)) AS STRIPPED THREADS ON EITHER THE VALVE OR CELL COVER MAY ALLOW CONTAINMENTS TO ENTER THE CELL ([220](#)). ANY STRIPPED THREADS REQUIRE COMPONENT REPLACEMENT.

- B. Using [T01](#), make sure the vent valve ([230](#)) of each cell ([220](#)) is closed and secure. Do not over-tighten.
- C. Remove white deposits (potassium carbonate) from tops of all cells ([220](#)) using a stiff bristled nonmetallic brush.

WARNING: TO PREVENT INJURY WHEN USING COMPRESSED AIR, DIRECT STREAM AWAY FROM BODY. USE SAFETY GOGGLES TO PREVENT EYE INJURIES FROM FINE DUST PARTICLES.

- D. Disperse residual salts and dust particles from the battery using blasts of clean, dry compressed air not over 1.38 bar (20 psi).
- E. Coat all nuts ([070](#)), ([140](#)), washers ([080](#)), ([150](#)), and links ([090](#) through [130](#)) with [M02](#).
- CAUTION:** SILICONE COATINGS ARE NOT SUITABLE DUE TO THE ALKALINE ELECTROLYTE.

- F. Clean the exterior surfaces of the battery cover ([030](#)) and battery case ([010](#) or [010A](#)) using a soft, clean cloth, moistened with water. Dry with compressed air not over 1.38 bar (20 psi) or a dry clean cloth.



COMPONENT MAINTENANCE MANUAL
1756-1 and 1756-3

3. Thorough Cleaning

- A. The battery must be discharged (refer to [Initial discharge](#) and [Cell shorting](#)) and disassembled (refer [DISASSEMBLY](#)).
- B. Remove greasy residue from power connector ([040](#)) with warm mild soapy [M03](#) water.
- C. After ensuring that the vent valves ([230](#)) are closed, wash each cell ([220](#)) in running water. Do not allow any water to enter the cell. Dry with compressed air not over 1.38 bar (20 psi) or a dry, clean cloth.
- D. Without submerging the connector of sensor harness ([160](#) or [160A](#)), wipe clean with damp cloth and let dry.
- E. Wash the battery case ([010](#) or [010A](#)), cover ([030](#)), spacers ([020](#)), gasket ([050](#)), and cell hardware ([090](#) through [150](#)), in warm mild soapy [M03](#) water to remove dirt and salt deposits. A plastic scraper or a stiff bristled brush (nonmetallic) may be used to aid in the removal of heavy deposits. Rinse away all [M03](#) and dry with compressed air not over 1.38 bar (20 psi) or a dry, clean cloth.



COMPONENT MAINTENANCE MANUAL
1756-1 and 1756-3

CHECK

1. General

This section contains new battery commissioning and component inspection information.

NOTE: All voltage readings are DC unless specifically otherwise stated.

NOTE: All () part identification numbers herein are [IPL Figure 1](#) item numbers.

2. Initial New Battery Commissioning

A. Before the initial charge, thoroughly inspect the battery assembly to ensure no damage has occurred during shipping or storage as follows:

NOTE: For a new battery not receiving its initial commission within one year of its DOM, then battery must follow [Figure 1002](#)

- (1) Inspect the battery case ([010](#) or [010A](#)) and cover ([030](#)) for dents, distortion, or other damage. If found, replace case ([010](#) or [010A](#)) or cover ([030](#)).
- (2) Remove the battery cover ([030](#)).
- (3) Visually verify the power connector ([040](#)) is present and undamaged.
- (4) Visually verify all cells ([220](#)) are positioned for proper polarity per [Figure 7002](#).
- (5) Visually verify all cells ([220](#)) are equipped with a vent valve ([230](#)).
- (6) Tighten all upper cell nuts ([140](#)) and connector nuts ([070](#)) per [Table 8001](#).
- (7) Visually verify the sensor harness ([160](#) or [160A](#)) is present and undamaged.

B. Charge the battery per [Charge](#) on page [1008](#) and level electrolyte per [Electrolyte level](#) on page [1010](#).

C. Perform successful [Battery insulation](#) test and install battery cover ([030](#)), then the battery is ready for service.

3. Component Inspection

A. Cell ([220](#))

- (1) Visually inspect for evidence of electrolyte leakage, cracks, corrosion, burns, holes, or cross-threaded terminals. Replace any defect cells with new Saft cells ([220](#)).
- (2) Excessive salt around a terminal post indicates leakage. Refer to [Terminal O-ring replacement](#) on page [6001](#) for replacement of lower terminal O-ring ([290](#)) if leakage is evident.
- (3) Visually check each cell vent valve ([230](#)) for defective O-rings ([240](#)), cracks, or other physical damage. Replace defective O-rings ([240](#)).
 - (a) Suspect vent valves should be tested in accordance with [Vent valve test](#) and/or be discarded.
- (4) Inspect the upper nuts ([250](#)) and washers ([270](#)), ([280](#)) to ensure it is free of bends, tarnish, corrosion, burns, or loss of plating. Minor tarnish can be polished off with a fine wire brush. Refer to [Cell hardware replacement](#) in [REPAIR](#).

B. Inspect the upper nuts ([070](#)), ([140](#)) and washers ([080](#)), ([150](#)) to ensure it is free of bends, tarnish, corrosion, burns, or loss of plating. Minor tarnish can be polished off with a fine wire brush. Defective hardware should be replaced.

24-32-06

5001
May 15/2023



COMPONENT MAINTENANCE MANUAL
1756-1 and 1756-3

- C. Intercell terminal links ([090](#) through [130](#))
Inspect for bends, tarnish, loss of nickel plating, corrosion, or burns. Tarnish can be polished off with a fine wire brush. Replace any defective intercell links.
- D. Spacers ([020](#))
The spacers ([020](#)) should be clean and free of cracks or holes. Replace any that are defective.
- E. Power connector ([040](#))
CAUTION: A DEFECTIVE BATTERY POWER CONNECTOR CAN CAUSE DANGEROUS OVERHEATING AND IN-SERVICE LOW VOLTAGE DURING DISCHARGE.
- (1) Check the power connector ([040](#)) for evidence of arching, corrosion, cracks, or cross threaded terminals.
 - (2) Using the method in [Battery insulation](#) check on page [1006](#), check the insulation between the positive pin and the connector shell and the negative pin and connector shell.
 - (3) Discard any power connector ([040](#)) that is found to have any of the above noted damage or fails the insulation test. Replace with new Saft power connector ([040](#)).
- F. Sensor harness ([160](#) or [160A](#))
- (1) Inspect electrical connector for bent or loose pins, corrosion, cracks, faulty wire connections, and evidence of arcing.
 - (2) Inspect charge control thermistor and midpoint voltage for damage, loose or broken wire connections, cracks, dents, or other physical defects.
 - (3) Visually check all wiring damage to insulation, cracked or broken wire, and other physical defects.
 - (4) Any evidence of the above conditions, however minor, is grounds for rejection. Discard the damaged unit and replace with a new Saft sensor harness ([160](#) or [160A](#)).
- NOTE:** Sensor harness ([160](#) or [160A](#)) is a non-repairable item and should be discarded if defective.
- G. Inspect cover ([030](#)) and case ([010](#) or [010A](#)) for damage. If found, replace with new Saft cover ([030](#)) or case ([010](#) or [010A](#)) as needed.



COMPONENT MAINTENANCE MANUAL
1756-1 and 1756-3

REPAIR

1. General

This section contains basic battery component procedures for removing and replacing components.

NOTE: The () part identification numbers herein are [IPL Figure 1](#) item numbers.

NOTE: All voltage readings are DC unless specifically otherwise stated.

2. Required Test Equipment

NOTE: Test equipment having equivalent specifications can be used.

Refer to [Special Tools, Fixtures, Equipment, and Consumables](#) for listing of Standard Tools.

3. Component Replacement

A. Cell replacement

Battery containing cell(s) require replacement. Note the [All cell replacement](#) recommendation below.

(1) All cell replacement

(a) For a battery compliant with the following then it is best to assume that all the original cells are or soon will be in unsatisfactory condition. Saft strongly recommends all cells ([220](#)) should be replaced with new Saft cells for a battery having:

1. 3 or more faulty cells are replaced during the same maintenance interval.

Or

2. 1 or more cells are found to be faulty during this maintenance period and 5 of the original cells in the battery had been previously replaced due faults.

3.

NOTE: The recommendation does not apply to the following failures:
terminal thread damage, cell leakage, or cell short-circuit

(2) Do [DISASSEMBLY](#) and [ASSEMBLY](#) to replace cells.

B. Cell hardware replacement

WARNING: USE CARE NOT TO TILT CELLS WHILE LOWER HARDWARE ARE LOOSENED OR REMOVED; CONTACT OF ELECTROLYTE WITH CAN CAUSE SEVERE BURNS.

NOTE: The battery should be discharged prior to starting cell hardware replacement.

(1) Replace necessary cell hardware ([250](#)), ([260](#)) or ([260A](#)), ([270](#)), ([280](#)) by removing and replacing the nuts ([070](#)), ([140](#)), washers ([080](#)), ([150](#)), and links ([090](#) to [130](#)). Torque nuts ([070](#)), ([140](#)), ([250](#)) per [Table 8001](#).



COMPONENT MAINTENANCE MANUAL
1756-1 and 1756-3

- C. Terminal O-ring ([290](#)) replacement
- (1) Remove necessary nuts ([070](#)), ([140](#)), washers ([080](#)), ([150](#)), and links ([090](#) to [130](#)).
 - (2) Remove lower terminal nut ([250](#)), polarity washer ([260](#)) or ([260A](#)), washers ([270](#)), ([280](#)) and terminal O-ring ([290](#)) being careful to prevent anything from falling into the cell opening.
 - (3) Replace O-ring ([290](#)), install washers ([280](#)), ([270](#)), the polarity washer ([260](#)) or ([260A](#)) and torque lower terminal nut ([250](#)) per [Table 8001](#).
 - (4) Install the necessary links ([090](#) to [130](#)), washers ([080](#)), ([150](#)), and torque nuts ([070](#)), ([140](#)) per [Table 8001](#) as required.

ASSEMBLY

1. General

This section contains assembly instructions necessary after disassembly.

NOTE: Make sure all components are clean and dry before re-assembly.

NOTE: All () part identification numbers herein are [IPL Figure 1](#) item numbers.

2. Sensor harness (160 or 160A)

A. Insert the connector of the temperature sensor with its gasket ([210](#)) into the case ([010](#) or [010A](#)), secure and torque the jam nut ([200](#)) to [Table 8001](#).

3. Spacers (020) and Cells (220)

A. Insert all spacers ([020](#)) as shown in [Figure 7001](#) and listed [Table 7001](#).

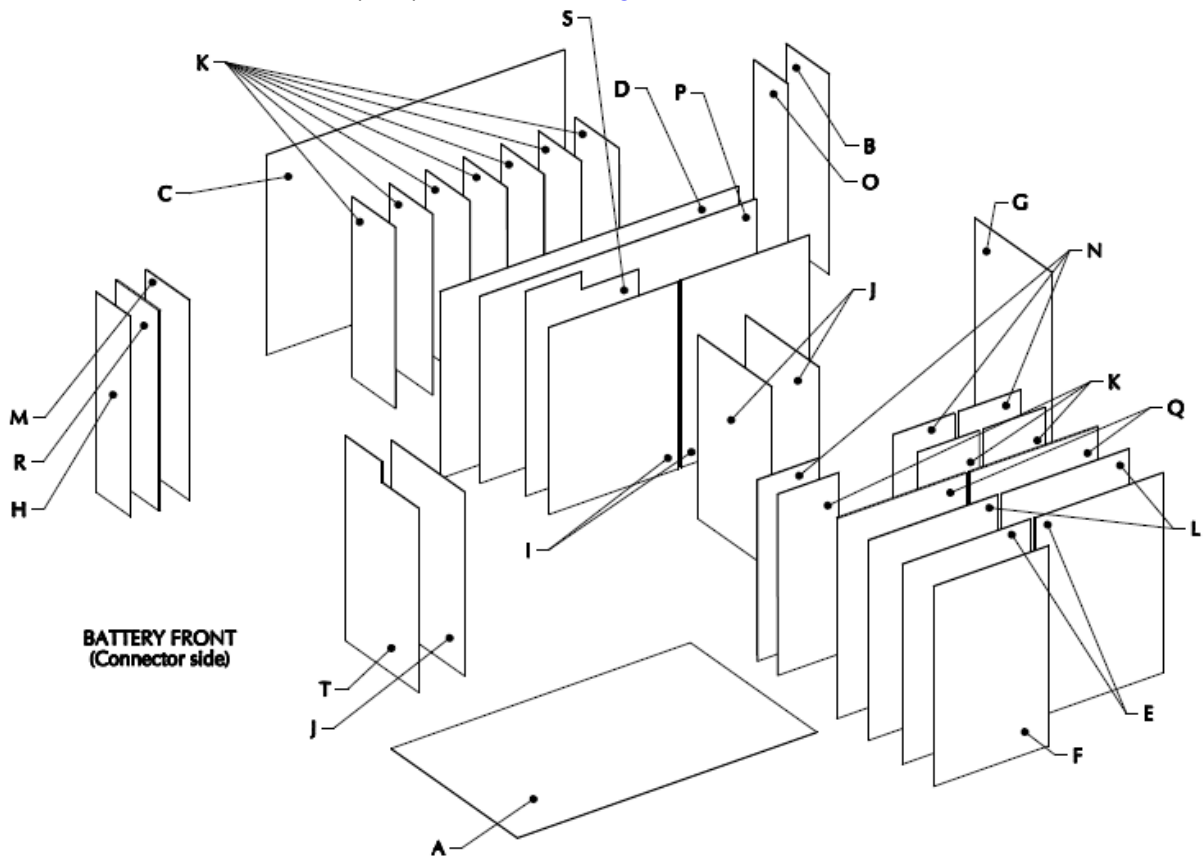

Battery Spacer Kit ([020](#))
Figure 7001



COMPONENT MAINTENANCE MANUAL
1756-1 and 1756-3

ITEM	DESCRIPTION	DIMENSION (IN)	UNITS PER ASSEMBLY
A	Spacer	10.550 x 6.300 x 0.015	1
B	Spacer	2.165 x 6.653 x 0.020	5
C	Spacer	10.512 x 6.653 x 0.020	4
D	Spacer	10.512 x 6.220 x 0.020	1
E	Spacer	4.527 x 6.653 x 0.020	3
F	Spacer	4.055 x 6.653 x 0.020	1
G	Spacer	3.858 x 6.653 x 0.020	3
H	Spacer	1.732 x 6.653 x 0.020	1
I	Spacer	4.528 x 6.220 x 0.020	2
J	Spacer	3.678 x 6.220 x 0.020	4
K	Spacer	2.165 x 6.024 x 0.020	13
L	Spacer	4.527 x 6.653 x 0.032	2
M	Spacer	2.16S x 6.653 x 0.032	4
N	Spacer	2.165 x 6.024 x 0.032	3
O	Spacer	1.700 x 6.653 x 0.032	1
P	Spacer	9.710 x 6.220 x 0.032	1
Q	Spacer	4.527 x 6.653 x 0.062	3
R	Spacer	2.165 x 6.653 x 0.062	4
S	Spacer	4.000 x 6.810 x 0.020 NOTCHED	1
T	Spacer	6.680 x 6.810 x 0.020 NOTCHED	1

Battery Spacer Kit ([020](#))
Table 7001

- B. Insert twenty cells ([220](#)), being careful to position them correctly for polarity as shown in [Figure 7002](#) on page [7003](#).
- C. Push in gently with a piece of softwood placed against the terminals.

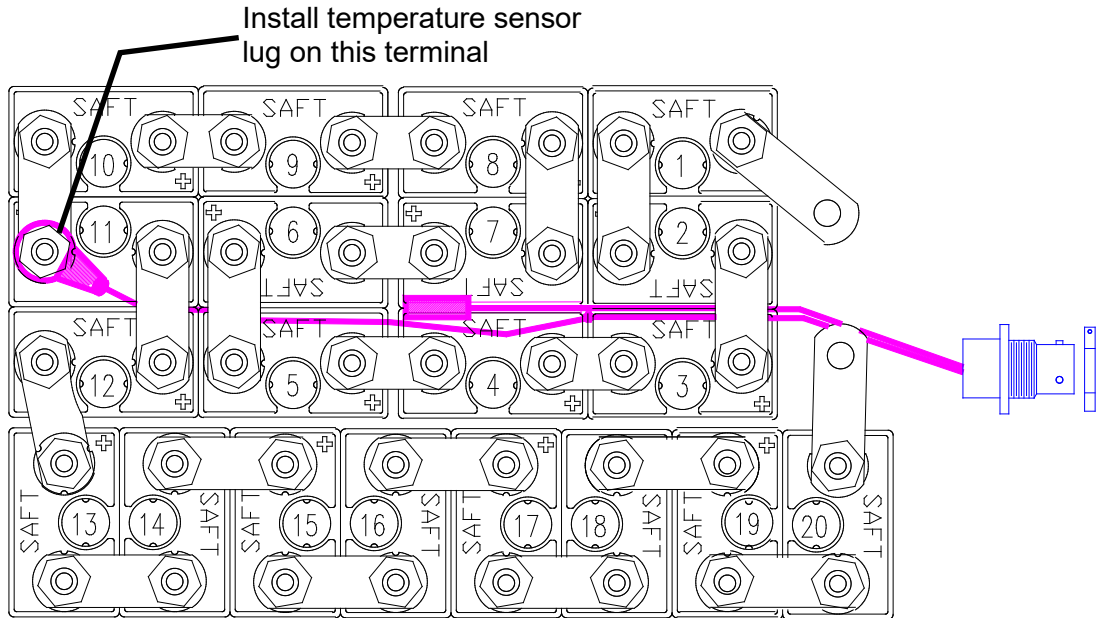

Battery Circuit
Figure 7002

4. Power connector (040)
 - A. Install the power connector (040) with its gasket (050) and torque with the four Sems screws (060) per [Table 8001](#).
5. Complete Battery
 - A. Install the links (090 through 130) on the terminals.
 - B. Lightly lube with [M02](#) the nuts, links, and connector contacts using a nonmetallic brush.
 - C. Install sensor lug to positive terminal of Cell #11 per [Figure 7002](#).
 - D. Install the washers (080), (150) and nuts (070), (140). Torque the nuts per [Table 8001](#).
 - E. Lightly lube with [M02](#) any other components that might be susceptible to atmospheric corrosion.
 - F. Install the cover (030) on the battery case (010 or 010A) and close the battery with the two latches.



COMPONENT MAINTENANCE MANUAL
1756-1 and 1756-3

PAGE INTENTIONALLY LEFT BLANK

24-32-06

7004
Mar 14/2022



COMPONENT MAINTENANCE MANUAL
1756-1 and 1756-3

FITS AND CLEARANCES

1. Torque Table

IPL FIGURE	ITEM NUMBER	TORQUE VALUE		NAME, LOCATION
		Nm	lb _r -in	
1	060	2.3 ± 0.2	20 ± 2	Screw, sems
1	070 , 140	8.0 ± 0.8	71 ± 7	Nut, Upper
1	200	5.93 ± 0.28	52.5 ± 2.5	Nut, Jam
1	250	5.0 ± 0.5	44 ± 4	Nut, Lower

Torque Values
Table 8001

2. Fits and Clearances Table

No fits and clearances required.



COMPONENT MAINTENANCE MANUAL
1756-1 and 1756-3

PAGE INTENTIONALLY LEFT BLANK

24-32-06

8002
Mar 14/2022

SPECIAL TOOLS, FIXTURES, EQUIPMENT, AND CONSUMABLES

1. Special Tools

A. Battery maintenance kit

NOTE: Equivalent tools can be used.

NOTE: A special tool kit (P/N 416161) is available from Saft containing special tools T01, T02, T03, and T04. The tools are housed in a polypropylene box.

- (1) [T02](#) (P/N 416231) is assembled using syringe P/N 105112 and nozzle P/N 016544. [T02](#) (P/N 020915-004) is assembled using syringe P/N 018327-000 and nozzle P/N 017536-004.
- (2) The [T02](#) (syringe) is used in the electrolyte level adjustment and the [T04](#) (cell puller) is used in cell removal.

ITEM	DESCRIPTION	09052 P/N	F6177 P/N
T01	Universal vent wrench	093365-000	413876
	Vent Valve Wrench (Figure 9001)	093382-000	-
T02	Syringe assembly with nozzle 20 mm (0.79 in) (Figure 9002)	020915-004	416231
T03	1.2Ω 3W equalizing resistors	-	164829
T04	Universal cell extraction tool	-	416159
	M8 x 1.25mm Tool (Figure 9003)	017557-000	-
T05	Vent Valve adapter	*024554-000 025098-000	-

* Part replaced by 025098-000

Special Tools
Table 9001

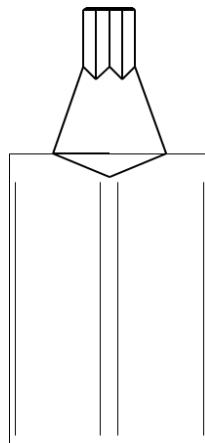

Wrench, Vent Valve
Figure 9001

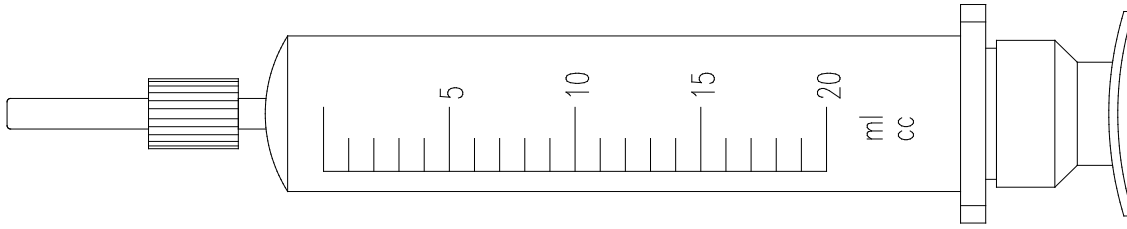

Syringe, 20cm³
Figure 9002

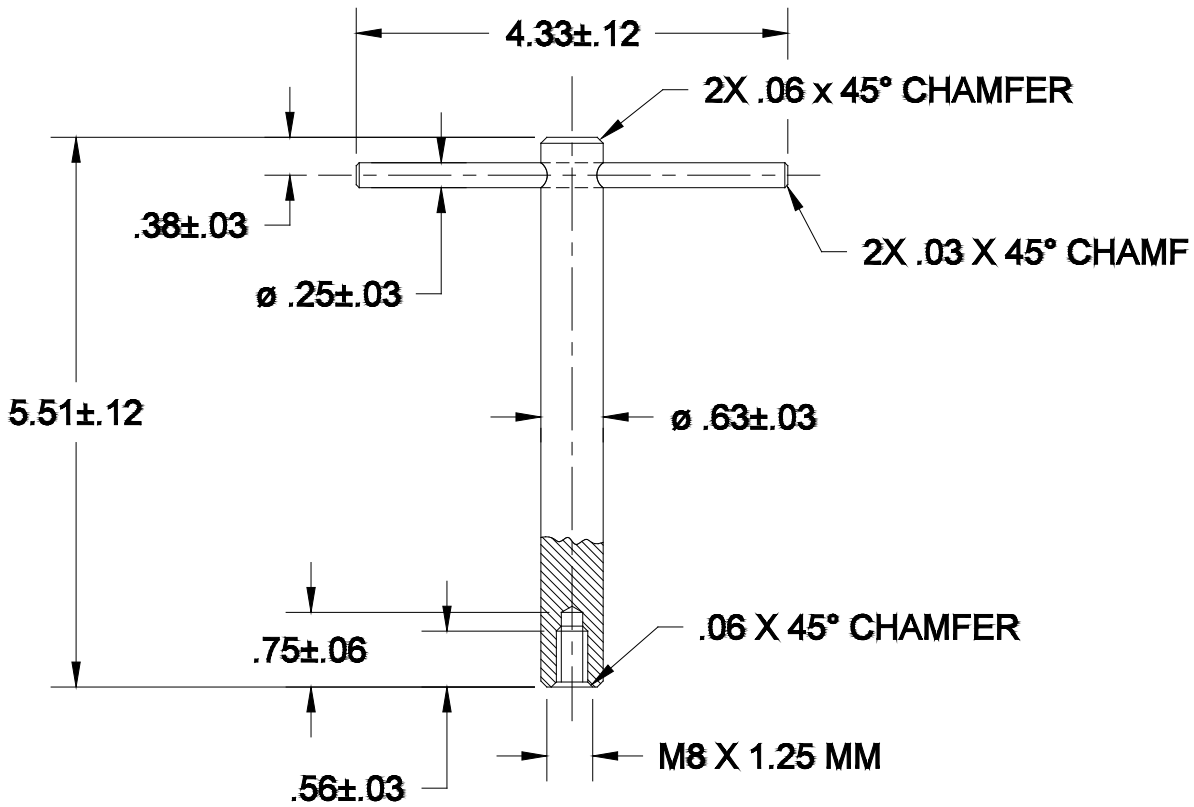

Wrench, Cell Extraction
(Dimensions in inches unless specified otherwise)
Figure 9003



COMPONENT MAINTENANCE MANUAL
1756-1 and 1756-3

2. Standard Tools

- A. The following items are recommended to do the procedures described in this manual. When necessary equivalent substitutes may be used.
- Constant current charger (DC current range 0 – 60A, minimum open DC voltage 40V)
 - Constant current load bank (DC current range 0 – 60 A, DC voltage range 1 – 40V)
 - Megohmmeter (0 – 50 M Ω @ 250 V DC continuous)
 - Precision Multimeter (Volt, Ω , mA) 2000 count, accuracy 1% or better
 - Torque Wrench (Insulated) 0 to 15 N-m (0 to 133 lb \cdot in)
 - Torque Screwdriver 0 to 3.4 N-m (0 to 30 lb \cdot in)
 - Thermometer, Immersion
 - Standard mechanic's tools
 - Safety gloves
 - Protective goggles
 - Safety shoes
 - Eye wash
 - Protective apron.
 - Stiff bristle brush (non-metallic)
 - Small paintbrush (non-metallic)
 - Dry, compressed air source [less than 1.38 bar (20 psi)]
 - Soft, clean cloth (at least two required)

24-32-06

9003
Nov 1/2022



COMPONENT MAINTENANCE MANUAL
1756-1 and 1756-3

3. Consumables

NOTE: Equivalent alternatives can be used for list items.

This paragraph describes the consumables used in the CMM.

ITEM	DESIGNATION PART NUMBER AND SPECIFICATION DESCRIPTION	MANUFACTURER OR SUPPLIER (NAME, ADDRESS, CODE)
M01	Distilled or deionized water @ +20°C ± 5°C (+68°F ± 9°F): Clear, colorless, and odorless while boiling Conductivity < 33 µS/cm 5 < pH < 7 Mn-COD < 30 mg/l (1.7 x 10 ⁻⁵ oz/in ³) (Chemical Oxygen Demand, methodology to evaluate organic or mineral pollution) Chlorines Cl ⁻ < 5 mg/l (2.9 x 10 ⁻⁶ oz/in ³) Sulfates SO ₄ ²⁻ < 10 mg/l (5.8 x 10 ⁻⁶ oz/in ³) STORAGE: dry and clean container without any corrosion and damage; Temperature: +20°C ± 5°C (+68°F ± 9°F). Over 1 year of storage, do an analysis of the liquid.	Local Vendor
M02	Neutral petroleum jelly Density @ +60°C (+140°F) Range = 0.840 to 0.866 kg/l (0.486 to 0.501 oz/in ³) Melting Point Range = +46°C to +52°C (+115°F to +126°F) Acidity/Alkalinity = Neutral to Litmus	Mineral Vaseline NATO: S 743 F: AIR 3565 US: VV-P-236A UK: DEF 2333
M03	Mild Soap	Local Vendor

Consumables
Table 9002

24-32-06

9004
Mar 14/2022



COMPONENT MAINTENANCE MANUAL
1756-1 and 1756-3

ILLUSTRATED PARTS LIST

1. Introduction

A. Purpose

This section provides illustrations and parts breakdown of the battery, which can be disassembled, replaced, and reassembled.

B. Explanation and usage of section

(1) Assembly order indenture system

The Indenture System used in the parts list shows the relationship of one part to another. For a given item, the number of indentures depicts the relationship of the item to the associated next higher assembly.

(2) Effectivity code

Reference letters (A, B, C, etc.) are assigned in the EFF CODE column to each top assembly. The reference letter of the applicable top assembly is also shown in the EFF CODE column for each detail part and subassembly except that no reference letter is shown for detail parts and subassemblies used on all top assemblies.

(3) Quantity per assembly

The UNITS PER ASSY column shows the total number of units required per assembly, per subassembly, and per sub-subassembly as applicable. The letters REF indicates the item is listed for reference purposes.

(4) Parts replacement data

Interchangeability information will be provided in a future manual revision if it becomes applicable.

(5) Service Bulletin incorporation

Service Bulletin incorporation information applicable to the parts list will be provided in a future manual revision if it becomes applicable.

(6) Items not illustrated

Items not illustrated are indicated by a dash (-) ahead of the item numbers in the FIGURE and ITEM NO. column.

24-32-06

10001
Mar 14/2022



COMPONENT MAINTENANCE MANUAL
1756-1 and 1756-3

- (7) Alpha variant item numbers
 - (a) Alpha variants A - Z (except I and O) are assigned to existing item numbers when necessary to show:
 - 1. Added items
 - 2. Service Bulletin modifications
 - 3. Configuration differences
 - 4. Optional parts
 - 5. Product improvement parts (non-service bulletin)
 - (b) Alpha variant item numbers are not shown on the exploded view when the appearance and location of the alpha variant item is the same as the basic item.
- (8) Vendors
The vendor of all parts shown in the parts list is as follows:

CAGE CODE	NAME / ADDRESS	CAGE CODE	NAME / ADDRESS
09052	Saft America Inc. 711 Gil Harbin Industrial Boulevard Valdosta, GA 31601, USA Phone: +1 (229) 247-2331 Fax: +1 (229) 247-8486	F6177	Saft 126 quai Charles Pasqua 92300 Levallois-Perret, France Phone: +33 1 58 63 16 00 Fax: +33 1 58 63 16 18



COMPONENT MAINTENANCE MANUAL
1756-1 and 1756-3

2. Numeric Index

PART NUMBER	AIRLINE STOCK NUMBER	FIGURE NUMBER	ITEM NUMBER	UNITS PER BATTERY
MS3186A111P			200	1
M25988-3-024			210	1
009384-000			050	1
015734-000			090	13
015735-000			100	1
015736-000			110	1
015737-000			120	5
015990-000			230	20
015995-000			070, 140, 250	82
017496-000			220	20
018124-000			080, 150, 270	82
018248-000			030	1
019728-000			130	1
021741-000			040	1
021870-000			280	2
022835-000		1	1	RF
022836-000			160	1
023048-000			010	1
023935-001			260	20
023935-002			260A	20
024637-000		1	1	RF
024638-000			010A	1
024639-000			160A	1
025340-000			020	1
091180-008			240, 290	60
093616-000			060	4

24-32-06

10003
Mar 14/2022

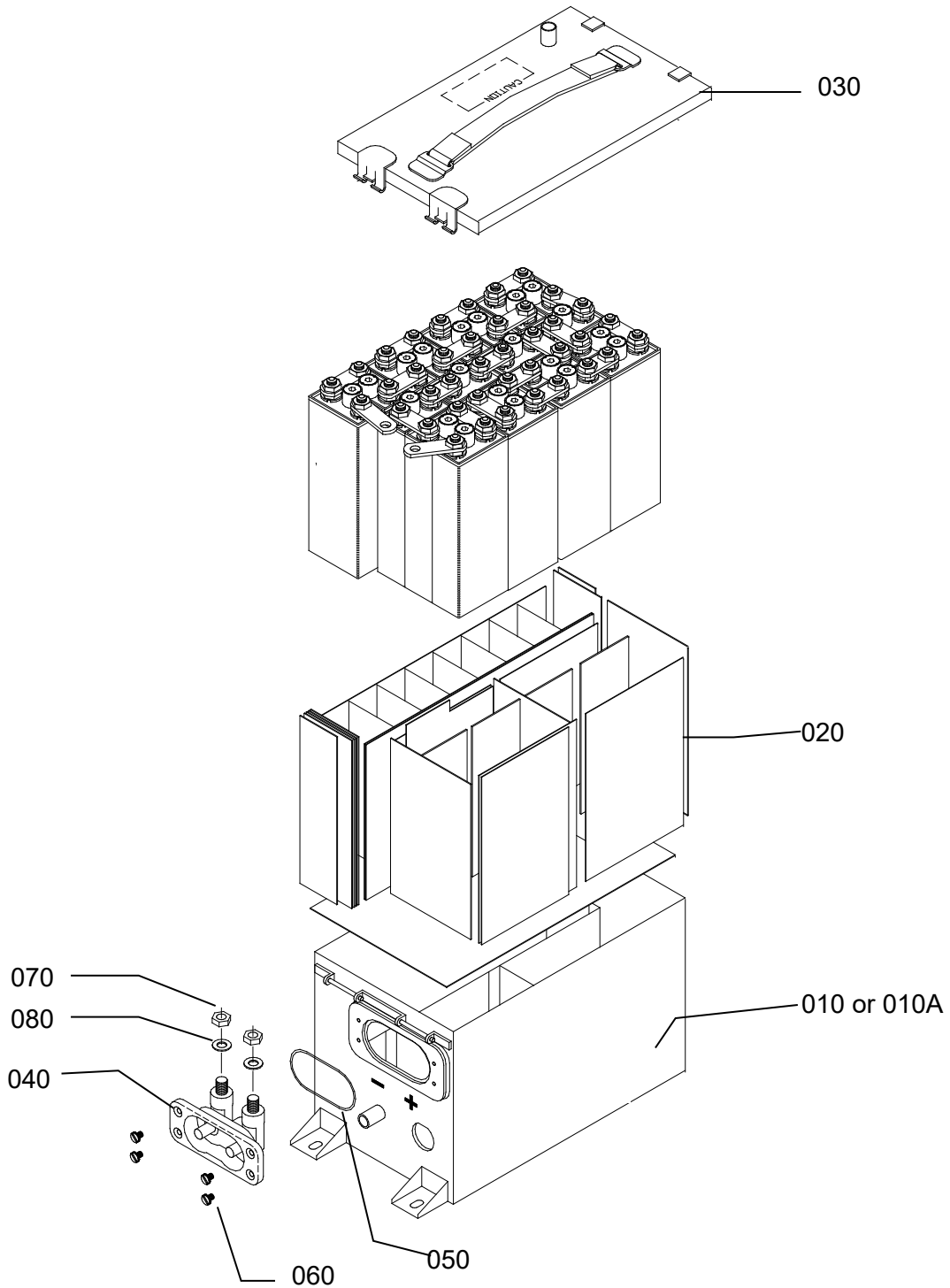

Battery, Exploded View
IPL Figure 1 (Sheet 1 of 4)



COMPONENT MAINTENANCE MANUAL
1756-1 and 1756-3

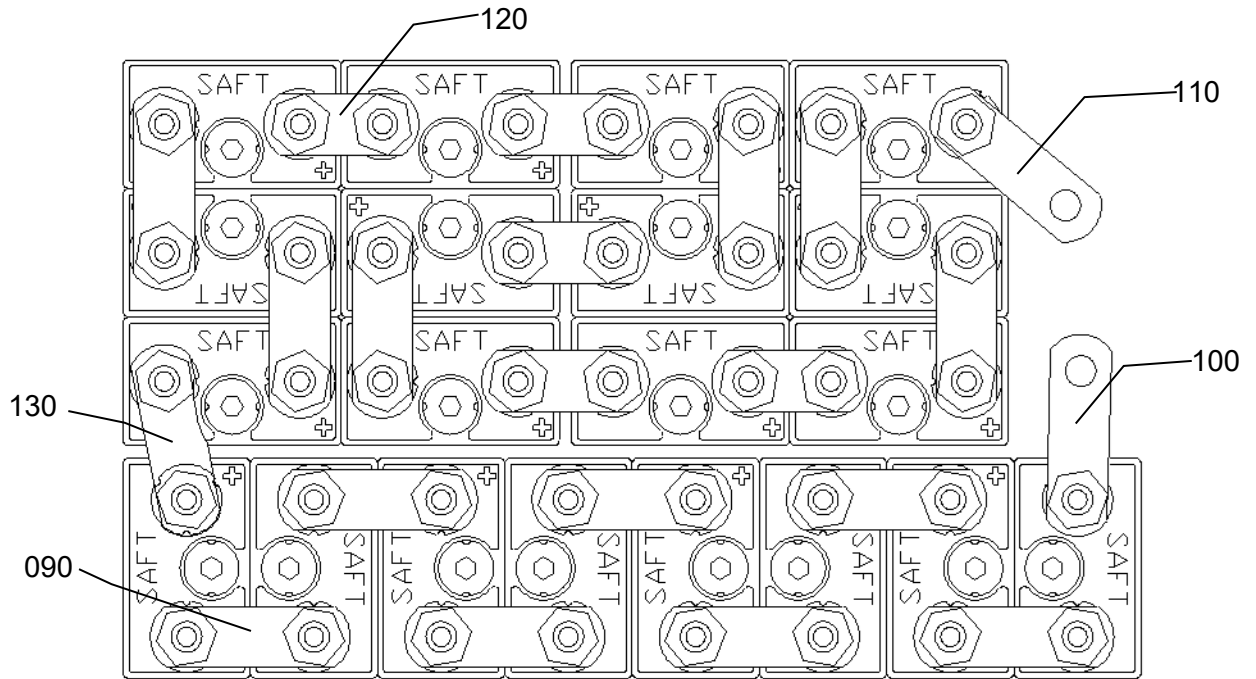

Battery, Exploded View
IPL Figure 1 (Sheet 2 of 4)

24-32-06

10005
Nov 1/2022

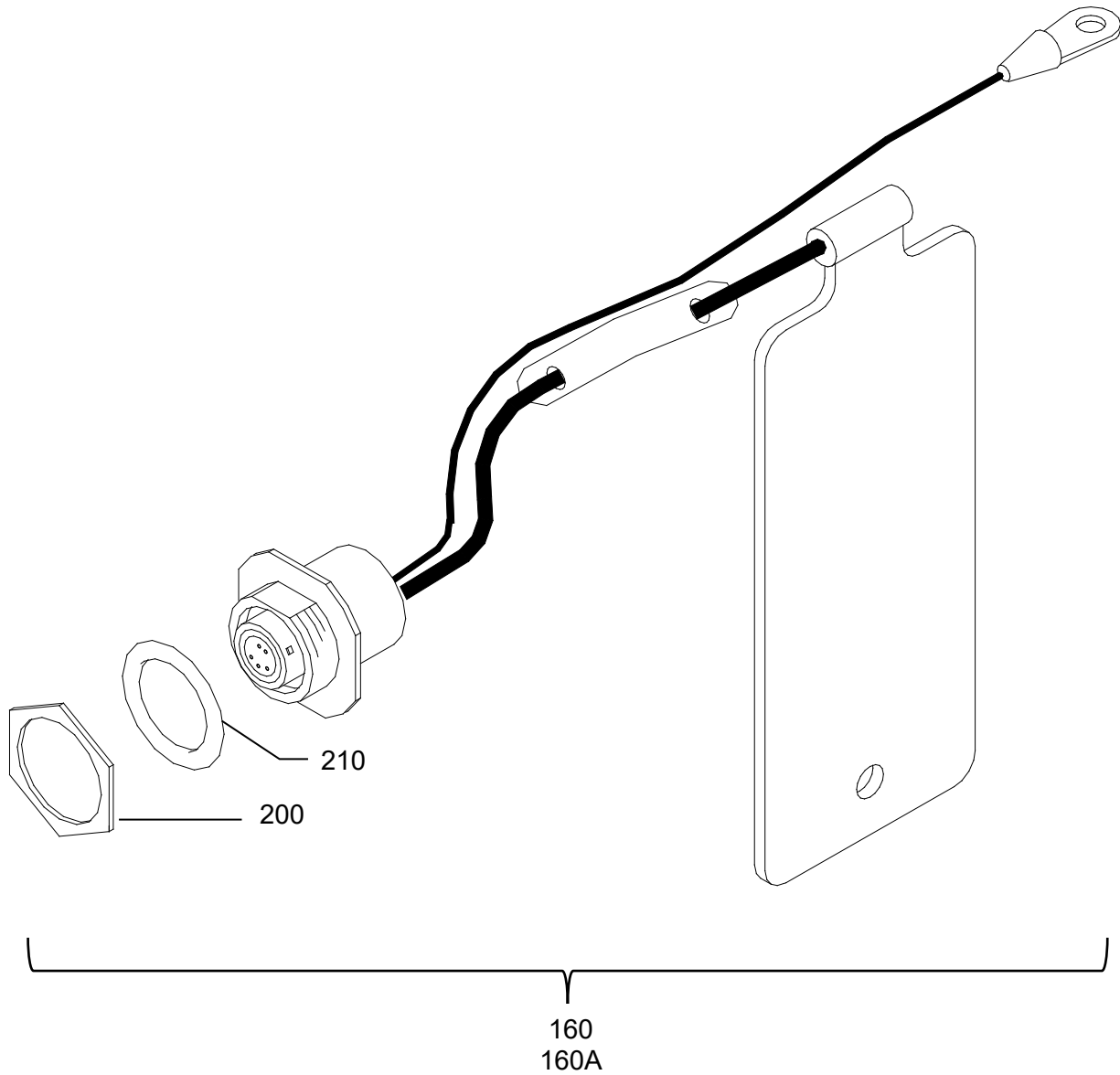

Battery, Exploded View
IPL Figure 1 (Sheet 3 of 4)

COMPONENT MAINTENANCE MANUAL 1756-1 and 1756-3

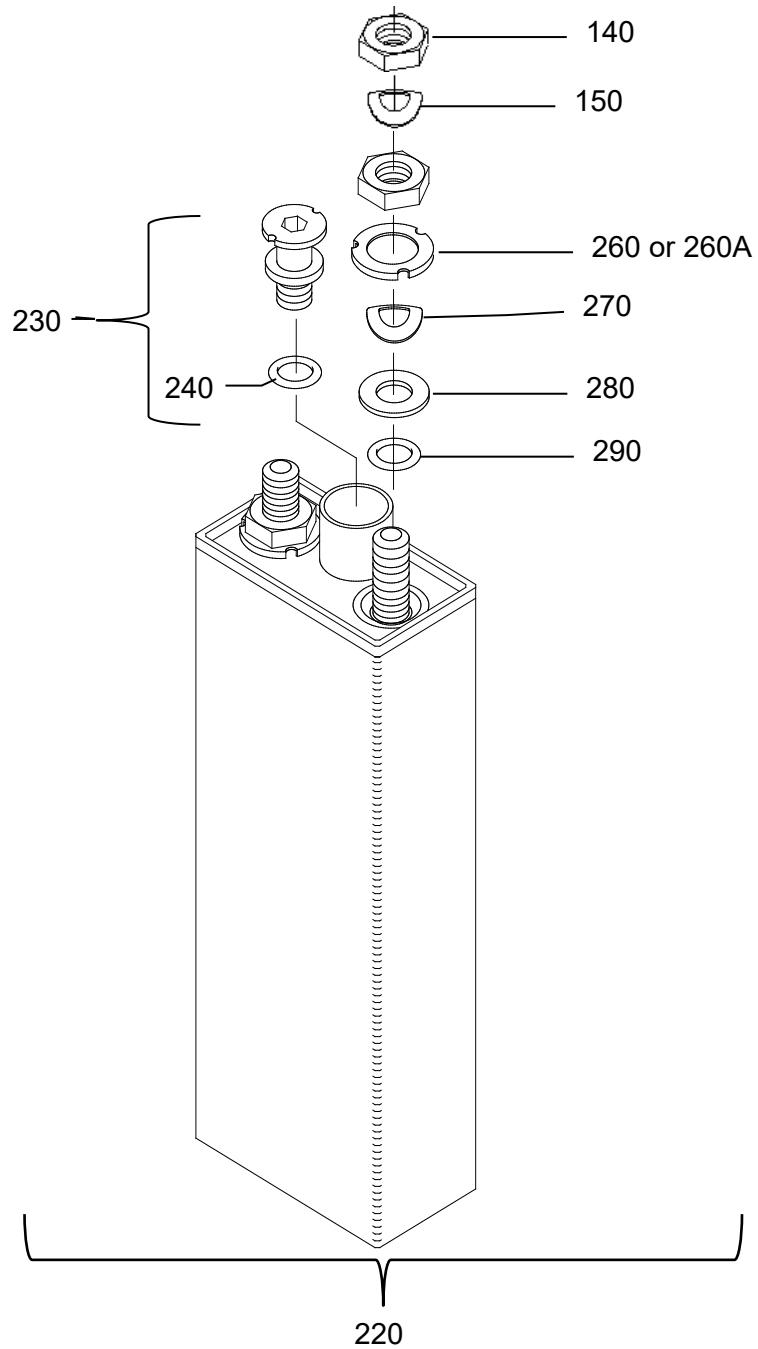

Battery, Exploded View
IPL Figure 1 (Sheet 4 of 4)



COMPONENT MAINTENANCE MANUAL
1756-1 and 1756-3

3. Detail Parts Lists

FIGURE & ITEM	MANUFACTURER'S PART NUMBER	AIRLINE PART NUMBER	DESCRIPTION 1 2 3 4 5 6 7	USAGE CODE	QTY
1 -1	022835-000		1756-1 Battery	A	RF
	024637-000		1756-3 Battery	B	RF
010	023048-000		. Case, Marked 1756-1	A	1
010A	024638-000		. Case, Marked 1756-3	B	1
011	N/A		. . Modification Label	B	1
			N/P		
020	025340-000		. . Kit, Spacer		1
030	018248-000		. Cover Assembly		1
040	021741-000		. Connector, Power		1
050	009384-000		. . Gasket		1
			Attaching Parts		
060	093616-000		. Screws, Sems * * *		4
070	015995-000		. Nut		2
080	018124-000		. Washer, Curved Spring		2
090	015734-000		. Link		13
100	015735-000		. Link		1
110	015736-000		. Link		1
120	015737-000		. Link		5
130	019728-000		. Link		1
140	015995-000		. Nut		40
150	018124-000		. Washer, Curved Spring		40
160	022836-000		. Harness, Sensor	A	1
160A	024639-000		. Harness, Sensor	B	1
			Attaching Parts		
200	MS3186A111P		. Nut * * *		1
210	M25988-3-024		. . O-Ring (TRUE P/N IS M25988/3-024)		1
220	017496-000		. Cell, VP170KH (with hardware)		20
230	015990-000		. . Valve, Vent		1
240	091180-008		. . . O-Ring (.301ID X .070THK)		1
250	015995-000		. . Nut		2
260	023935-001		. . Polarity Washer, Red		1
260A	023935-002		. . Polarity Washer, Blue		1
270	018124-000		. . Washer, Curved Spring		2
280	015999-000		. . Washer, Flat		2
290	091180-008		. . O-Ring		2

DASH (-) ITEM NOT ILLUSTRATED

24-32-06

10008
Nov 1/2022



COMPONENT MAINTENANCE MANUAL
1756-1 and 1756-3

STORAGE (INCLUDING TRANSPORTATION)

1. Storage

- A. Storage preparation and packaging makes sure the equipment is protected against any attack by atmospheric agents.
- B. For a battery which has been cleaned and serviced and is not directly put into service on board an aircraft, different methods can be recommended depending on the purpose and the environment conditions of the "storage".
- C. Keep the batteries and spares in a dry and clean room.

2. Inactive Long-term Storage

A. Procedure

(1) The following must be done to any battery with prior service history.

(a) [Charge](#), [Electrolyte level](#), [Vent valve test](#), and [Capacity test](#).

NOTE: It is not necessary that it be short circuited. There is no need of maintenance operation during the storage period.

NOTE: The standard cardboard packaging is considered unsealed and allows 2 years of storage. Storage is allowed for 10 years if the following conditions are met: sealed packaging and isolated from harmful agents (i.e.: dirt, dust, vibrations, or corrosive atmosphere).

- sealed packaging,
- temperature: +5°C to +35°C (+41°F to +95°F),
- humidity < 90%,
- normal vertical position,
- Isolated from detrimental agents: i.e., dirt, dust, dampness, vibration, corrosive atmosphere.

(2) Saft Ni-Cd batteries may be stored in temperatures ranging from -55°C to +5°C or +35°C to +60°C (-67°F to +41°F or +95°F to +140°F) for an accumulated exposure that does not exceed 30 days.

(3) Lead batteries must not be stored in the same room.

B. Servicing at end of long-term storage

STORAGE TIME	SERVICE PROCEDURE
Less than or equal to 12 months	Do Visual inspection and return to Figure 1002 entry point " C "
More than 12 months	Do Charge and return to Figure 1002 entry point " Regular Check "

Return to Service Following Storage
Table 15001

3. Inactive Standby Storage

The battery is charged after being serviced then stored fully charged in a dedicated room in such a way that it can be installed in the aircraft without further maintenance except as provided within this section. Refer to [Figure 15002](#).

NOTE: At any time during the Inactive standby storage shown in [Figure 15002](#), the battery may be installed on the aircraft or placed into [Inactive Long-Term Storage](#).

NOTE: For a battery previously stored at a temperature below ambient temperature, condensation within the battery may occur, do [Battery insulation](#) before installation.

A. Standby period is the rest time that corresponds to 80% available capacity shown in [Figure 15001](#). For example, maximum 24 days at +30°C (*86°F) or maximum 90 days for temperatures ≤ +23°C (+73°F).

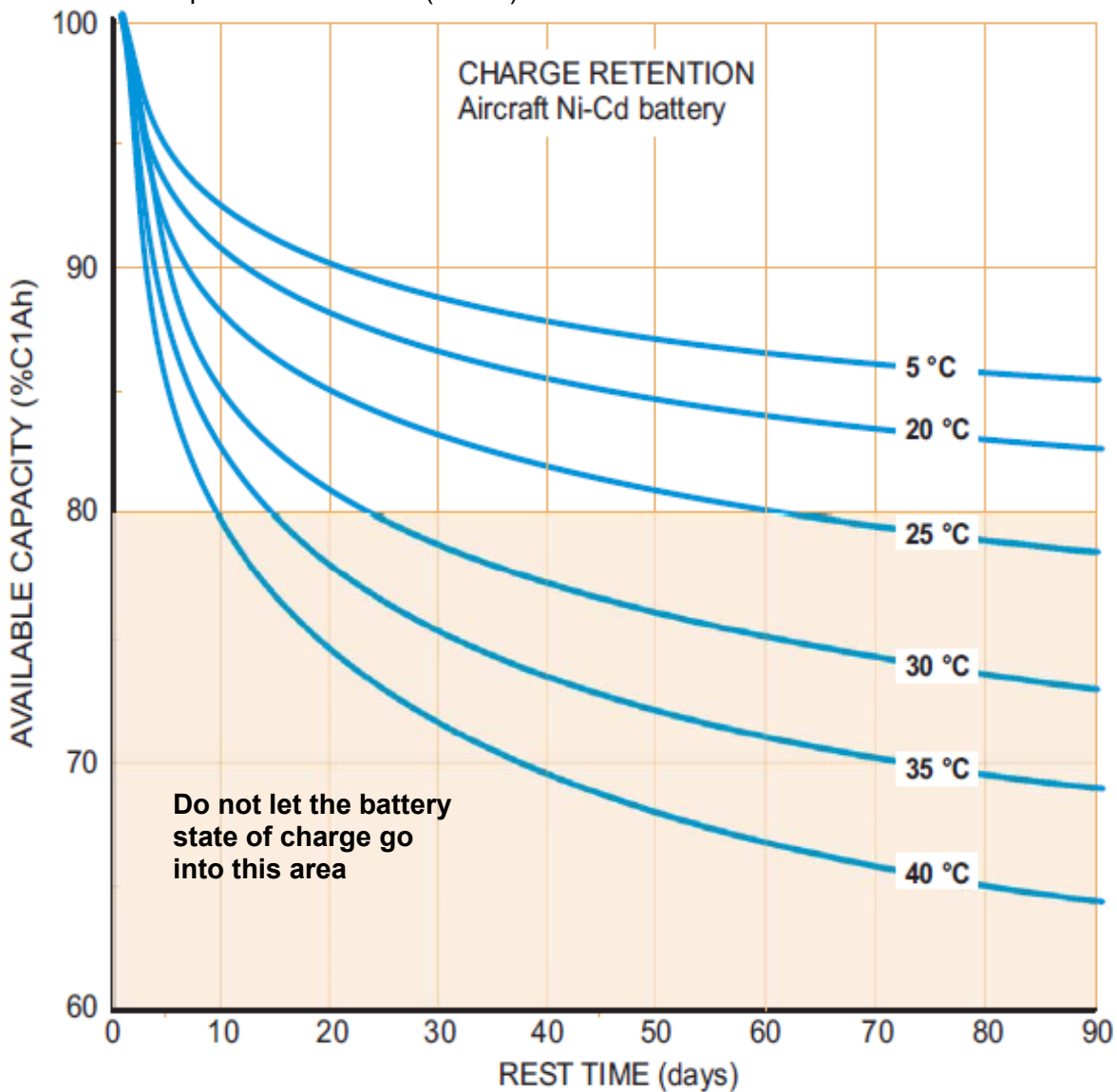

Standby Period
Figure 15001



COMPONENT MAINTENANCE MANUAL
1756-1 and 1756-3

- B. Refresh charge is a quick constant current charge that can be done at the end of a [Standby period](#) to extend the time the battery is in inactive standby storage. The charge is given in [Table 15002](#).

CAUTION: DO NOT DO THE 4 HOURS FINAL CHARGE AT 0.1 C₁A (REFER TO [CHARGE](#)) DURING THIS 'REFRESH' CHARGE OPERATION.

CHARGE RATE	VOLTAGE (END OF "REFRESH" CHARGE)
0.1C ₁ A	30.0V for 20 Cells
0.5C ₁ A	31.0V for 20 Cells
1.0C ₁ A	31.4V for 20 Cells

Refresh Charge
Table 15002

- C. Standby duration consists of a maximum of 3 standby periods with 2 refresh charges. The number of consecutive standby durations is limited to 3. Refer to [Figure 15002](#).
- (1) For a battery completing the first or second standby duration and not immediately installed in the aircraft or sent into long-term storage, do the one of the following:
 - (a) For environments ≤ +30°C (+86°F) do [Battery insulation](#), [Initial discharge](#), [Charge](#), [Electrolyte level](#), and [Battery insulation](#).
 - (b) For environments > +30°C (+86°F) do [Battery insulation](#), [Initial discharge](#), [Cell shorting](#), [Charge](#), [Electrolyte level](#), and [Battery insulation](#).
 - (2) For a battery completing the third consecutive standby durations, the battery can go into [Inactive Long-Term Storage](#) or return to [Figure 1002](#).
- D. Standby storage cycle schedule is limited to the [Standby duration](#) being conducted a maximum of 3 times as shown in [Figure 15002](#).

NOTE: Anytime during this standby storage cycle shown in [Figure 15002](#), the battery may be installed on the aircraft or placed into [Inactive Long-Term Storage](#).

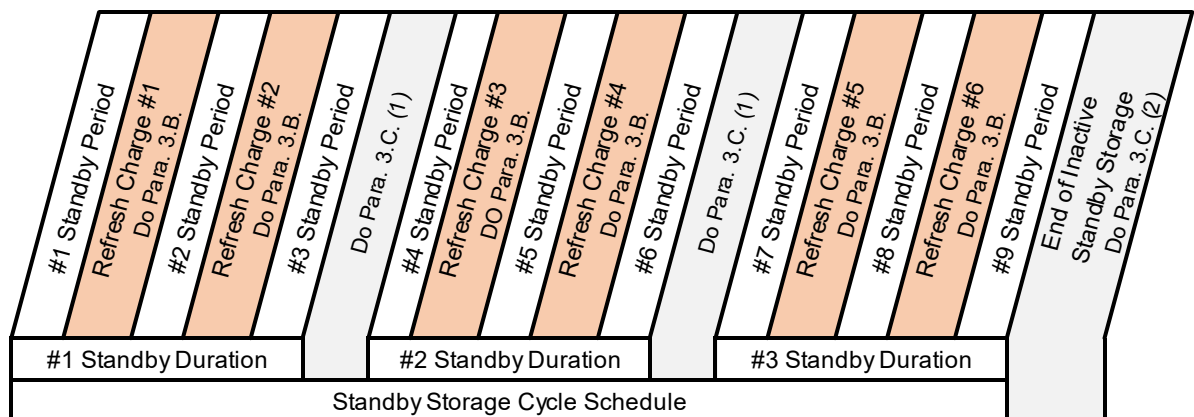

Inactive Standby Storage Schedule
Figure 15002



COMPONENT MAINTENANCE MANUAL
1756-1 and 1756-3

4. Active Standby Mode (trickle charge)

CAUTION: WATER CONSUMPTION OCCURS WHEN THE BATTERY IS CONTINUOUSLY CHARGED, IN AN OVERCHARGE CONDITION. SAFT DOES NOT RECOMMEND THIS METHOD, HOWEVER SOME OPERATORS TAKE RESPONSIBILITY FOR ITS USE.

NOTE: This method is not reliable due to quantity and inaccuracy of water consumption.

This method is not reliable due to quantity and inaccuracy of water consumption.

Example: A 40 Ah battery on a continuous trickle charge of 3 mA/Ah for one month may consume over 35 cm³/cell (2.14 in³/cell) of water.

5. Storage of spare parts

A. Spare Cells

Spare cells must be stored in a vertical upright position, filled, and discharged condition (electrolyte levels are not visible in discharged cells). It is not necessary to short circuit the cells. The vent valves must be installed. The storage conditions are the same as those given in paragraph Inactive long-term storage. No maintenance operation is needed during storage. Before installation in a battery, cells must be visually inspected for damage or leakage and repaired as necessary in accordance with this CMM.

B. Spare O-rings, gaskets, and vent valves

(1) O-rings and gaskets

Six (6) years of storage period starts from the date of manufacture unless otherwise specified on the packaging. The O-rings and gaskets should be protected from exposure to the air, light, and high humidity < 85%. Storage life depends on temperature. It is recommended to store the parts in a cool area < +25°C (+77°F). Above +35°C (+95°F), storage life is reduced to 5 years. Before use the O-rings or gaskets it must be inspected. In case of visible signs of damage, distortion, or deterioration, the part must be discarded.

O-rings must be inspected before use and must be disregarded if there are visible signs of damage, distortion, or deterioration.

(2) Vent valves with O-rings

Six (6) years of storage period starts from the date of manufacture unless otherwise specified on the packaging. The vent valves and O-rings should be protected from exposure of air, light and high humidity (< 85%). Storage life depends on temperature. It is recommended to store the parts in a sealed container (non-PVC) in a cool area < +25°C (+77°F). Above +35°C (+95°F), storage life is reduced to 5 years. Before use the vent valves and O-rings it must be inspected. In case of visible signs of damage, deformation, or deterioration, the vent valve and O-ring must be discarded.

C. Other spares

Other spares, protected from external contamination (i.e. dirt, dust, dampness, vibration, corrosive atmosphere) and high humidity (> 85%), may be stored for unlimited periods. Before use, they must be inspected and any showing visible signs of damage, distortion or deterioration must be discarded.



COMPONENT MAINTENANCE MANUAL
1756-1 and 1756-3

6. Transportation procedure

The battery is normally discharged before packing. If it is necessary to transport a charged battery, make sure that the output terminals are protected against short circuit.

The battery should then be packed vertically in its original container. If the original container is not available, the international and/or local packaging regulations applicable to the mode of transport and destination must be followed.

According to the IATA / IMDG dangerous goods regulations, Saft ships all existing nickel-cadmium batteries or cells for aircraft under the classification UN2795 (wet, filled with alkali).

24-32-06

15005
Nov 1/2022



COMPONENT MAINTENANCE MANUAL
1756-1 and 1756-3

PAGE INTENTIONALLY LEFT BLANK

24-32-06

15006
Nov 1/2022