

No. EC155-71A015

Civil version(s): B, B1



ALERT SERVICE BULLETIN

CORRECTIVE MEASURE

POWER PLANT - Firewall

Modification of the material of the firewall edging

Related to modification 0771C59

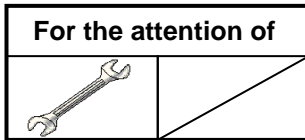
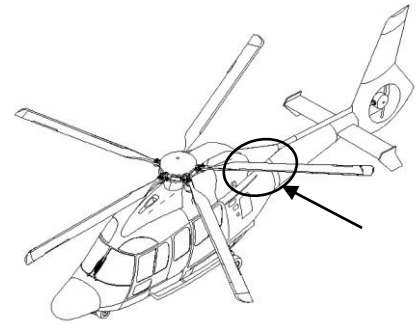

Revision No.	Date of issue
Revision 0	2022-10-25

Summary:

The function of this ALERT SERVICE BULLETIN is to replace the aluminum stiffener on the center firewall with a titanium stiffener in order to ensure the correct behavior of the central firewall seal in case of fire.

Compliance:

It is mandatory to comply with this ALERT SERVICE BULLETIN.

No. EC155-71A015

1. PLANNING INFORMATION

1.A. EFFECTIVITY



CAUTION

MAKE SURE THAT THE MODIFICATIONS RELATED TO THIS ALERT SERVICE BULLETIN AGREE WITH THE HELICOPTER CONFIGURATION AT THIS TIME. IF THE MODIFICATIONS DO NOT AGREE WITH THE HELICOPTER CONFIGURATION:

- PREPARE THE NECESSARY ADAPTATION WORK.
- GET THE APPROVAL BY THE APPLICABLE LOCAL AIR TRANSPORT AUTHORITIES.
- COMPLY WITH THE AIRWORTHINESS REQUIREMENTS.

THIS ALERT SERVICE BULLETIN IS WRITTEN FOR THE INITIAL HELICOPTER CONFIGURATION SPECIFIED IN THE INDIVIDUAL INSPECTION LOG BOOK. IT INCLUDES ONLY THE POST-DELIVERY CONFIGURATION CHANGES WHICH ARE KNOWN AND APPROVED BY AIRBUS HELICOPTERS.

1.A.1. Helicopters/installed equipment or parts

Helicopter versions B, B1 equipped with stiffener (axial U trimming) P/N: 365A58-1475-20.

1.A.2. Non-installed equipment or parts

Stiffener (axial U trimming) P/N: 365A58-1475-20.

1.B. ASSOCIATED REQUIREMENTS

Not applicable.

1.C. REASON

The investigation following a fire in a left engine compartment highlighted the failure of the upper stiffener of the central firewall. This part being in aluminum, it can lead to a distortion of the firewall and a loss of tightness of the central firewall seal if submitted to a fire.

Airbus Helicopters introduces modification 0771C59 to replace the aluminum stiffener on the center firewall with a titanium stiffener in order to ensure the correct behavior of the central firewall seal in case of fire.

No. EC155-71A015

1.D. DESCRIPTION

This ALERT SERVICE BULLETIN includes the work steps that follow:

- Removal of the aluminum stiffener from the engine firewall
- Installation of the titanium stiffener on the engine firewall.

1.E. COMPLIANCE

1.E.1. Compliance at H/C manufacturer level

Helicopters/installed equipment or parts:

For Airbus Helicopters, it is necessary to comply with the instructions of paragraph [3.](#) of this ALERT SERVICE BULLETIN before the delivery of the helicopter.

Non-installed equipment or parts:

For Airbus Helicopters, it is necessary to comply with the instructions of paragraph [3.](#) of this ALERT SERVICE BULLETIN before the delivery of the helicopter

1.E.2. Compliance in service

Helicopters/installed equipment or parts:

It is the operator who does the work on the helicopter.

Comply with paragraph [3.](#) within 600 FH or no later than within 24 months after you received this ALERT SERVICE BULLETIN. Refer to the issue date on the page footer.

Non-installed equipment or parts:

When you receive this ALERT SERVICE BULLETIN, discard the stock of part listed in paragraph [1.A.2.](#)

1.F. APPROVAL

Approval of modifications:

The information or instructions relate to modification 0771C59, which was approved through CRD DA07.71C59B Rev.2 on April 04, 2022 under the authority of EASA Design Organization Approval No. 21J.700 for civil version helicopters subject to an Airworthiness Certificate.



Approval of this document:

The technical information contained in this ALERT SERVICE BULLETIN Revision 0 was approved on October 11, 2022 under the authority of EASA Design Organization Approval No. 21J.700 for civil version helicopters subject to an Airworthiness Certificate.

1.G. MANPOWER



Airbus Helicopters recommends that the personnel who will do this ALERT SERVICE BULLETIN have this qualification:

Qualification: 1 Airframe Technician.



The man-hours are an estimate given for information only and for a standard helicopter configuration.

Estimated Man-hours: 7 hours for the Airframe Technician.



The helicopter downtime is an estimate given for information only and for a standard helicopter configuration.

The estimate of the helicopter downtime is one day.

1.H. WEIGHT AND BALANCE



Weight: + 0.06 kg

Moment:

- Longitudinal: + 0.3 m.kg

After you complete the work, record the new weight and moment in your applicable document.

1.I. POWER CONSUMPTION

Not changed.

1.J. SOFTWARE UPGRADES/UPDATES

Not applicable.

1.K. REFERENCES

These documents are necessary to comply with this ALERT SERVICE BULLETIN:

Standard Practices Manual (MTC):

- MTC: 20-02-04-401: Installation of rivets - pitch and edge distance - Riveting
- MTC: 20-02-04-601: General riveting acceptance requirements - Riveting
- MTC: 20-02-05-401: Joining by riveting - Joining
- MTC: 20-02-05-404: Assembly by screws and nuts - Joining
- MTC: 20-02-09-101: Crack detection through dye-penetrant inspection: General
- MTC: 20-02-09-601: Checking structural parts / components using the dye penetrant procedure
- MTC: 20-03-01-102: General repair instructions - Unriveting principle - General repair instructions
- MTC: 20-03-02-102: Identification of standardized rivets - General rivet replacement principles
- MTC: 20-03-02-401: Installation of normal rivets - General rivet replacement principles
- MTC: 20-04-05-402: Application of Primer EPOXY P05-P20 - Paint and primer application procedure

No. EC155-71A015

MTC: 20-05-01-222: Application of PR 1771 B2 sealant - General sealing procedures
MTC: 20-05-01-227: Application of Jointing Compound CA 1010 - General sealing procedures
MTC: 20-07-02-201: Helicopter parked in a repair shop - Safety instructions
MTC: 20-07-03-408: Appearance checks on an aircraft after inspection or repair - Technical instructions
MTC: 20-08-05-103: Monitoring of parts in operation - marking - service life customization - General rules applicable to aircraft

Aircraft Maintenance Manual (AMM):

AMM: 53-54-00-061: Removal / Installation - Engine Cowlings
AMM: 71-30-00-961: Replacement of Cowlings Seals on Firewall

Information Notice (IN):

IN 3481-I-00: The Marketplace: an AirbusWorld eOrdering service
IN 3785-I-00: Introduction of the digital Service Bulletin reporting service SB Insight
IN 3686-I-00: Publishing of complementary Instructions for Continued Airworthiness through Delivery Notes

1.L. OTHER AFFECTED PUBLICATIONS



CAUTION

TO COMPLY WITH THIS ALERT SERVICE BULLETIN, THE OPERATOR MUST MAKE SURE THAT ALL THE MAINTENANCE DOCUMENTS NECESSARY FOR THE MAINTENANCE OF THIS INSTALLATION ARE AVAILABLE. IF THEY ARE NOT AVAILABLE, THE OPERATOR MUST CONTACT AIRBUS HELICOPTERS TO GET THESE DOCUMENTS.

The changes to Instructions for Continued Airworthiness (ICA) which are required as a result of this ALERT SERVICE BULLETIN will be incorporated in the next Normal Revision.
Refer to DN.105.0003.0 until the information is available in the published technical documentation.

NOTE

You can find more information about Delivery Notes in Information Notice IN 3686-I-00.

1.M. PART INTERCHANGEABILITY OR MIXABILITY

Interchangeability:

PRE MOD and POST MOD components are not interchangeable.

Mixability:

This ALERT SERVICE BULLETIN has no effect on mixability.

No. EC155-71A015

2. EQUIPMENT OR PARTS INFORMATION

2.A. EQUIPMENT OR PARTS: PRICE - AVAILABILITY - PROCUREMENT

Price

For information about the price of the modification kits and/or components, or for aid, contact the Airbus Helicopters Network Sales and Customer Relations Department.

Availability

Contact the Sales and Customer Relations Department to know the delivery lead times.

Procurement

Send an order for the necessary quantities to the Airbus Helicopters Network Sales and Customer Relations Department:

Airbus Helicopters
Etablissement de Marignane
Direction Ventes et Relations Client
13725 MARIIGNANE CEDEX
FRANCE

In the purchase order, write the information that follows:

- The mode of transport
- The destination
- The serial numbers of the helicopters to change.

2.B. LOGISTIC INFORMATION

Not applicable.

No. EC155-71A015

2.C. EQUIPMENT OR PARTS REQUIRED PER HELICOPTER/COMPONENT

Kits to be ordered for one helicopter or one assembly:

Key Word	Qty	New Reference	Item	Former Reference →	Instruction
FIREWALL RETROFIT KIT		365A07-71C5-9272			
Stiffener	1	365A58-1475-2151	1	365A58-1475-20	Discard
Solid universal head rivet	7	NAS1398C3-1	2		
Hex. head bolt	17	22125TK050012X	3		
Washer	17	23111CA050	4		
Self-locking hex. nut	17	ASN52320BH050N	5		

Equipment or parts to be ordered separately:

Key Word	Qty	New Reference	Item	Former Reference →	Instruction
Bracket		365A58-1102-NY	12		Replace if in unsatisfactory condition
Rivet (blind)	2	ASNA0078E403	13		

Consumables to be ordered separately:

Refer to the Work Cards and Tasks identified in this ALERT SERVICE BULLETIN or use equivalents.

Key Word	Qty	Reference	CM	Item
Interposition sealant	0.25 L	ECS7009	CM518	11
Sealing compound	0.25 L	ECS0045-3232	CM6068	14

You can send an order for the consumables from the AirbusWorld Marketplace through e-ordering (IN 3481-I-00).

If you cannot get access to e-ordering, please contact your Logistic Focal Point.

Special tools:

Refer to the Tasks and Work Cards identified in this ALERT SERVICE BULLETIN or use equivalents.

2.D. EQUIPMENT OR PARTS TO BE RETURNED

Not applicable.

3. ACCOMPLISHMENT INSTRUCTIONS

3.A. GENERAL

- Comply with the general instructions on the installation of rivets, pitch and edge distance. Refer to Work Card 20-02-04-401 (MTC).
- Comply with the general riveting acceptance requirements. Refer to Work Card 20-02-04-601 (MTC).
- Comply with the general crack detection instructions with dye-penetrant. Refer to Work Card 20-02-09-101 (MTC)
- Comply with the general checking procedure on the structural parts / components with dye-penetrant. Refer to Work Card 20-02-09-601 (MTC).
- Comply with the general instructions to join by riveting. Refer to Work Card 20-02-05-401 (MTC).
- Comply with the general instructions on the identification of standardized rivets. Refer to Work Card 20-03-02-102 (MTC).

Unless specified differently, tighten the bolts to the standard torque. Refer to Work Card 20-02-05-404 (MTC).

3.B. WORK STEPS



CAUTION

MAKE SURE THAT YOU PREVENT ALL POSSIBLE FOREIGN OBJECT DAMAGE (FOD).

3.B.1. Preliminary steps

- Park the helicopter in a hangar. Refer to Work Card 20-07-02-201 (MTC).
- Disconnect all the electrical power supplies.
- Remove and/or open all applicable cowlings, panels, doors and other items of equipment to get access to the different work areas.
- Remove the cowlings and fairings. Refer to Task 53-54-00-061 (AMM).

3.B.2. Procedure

NOTE 1

Cutout and drilling: Work Card 20-04-04-401 (MTC) gives information on deburring and protection.

NOTE 2

Paint touch-ups are the responsibility of the operator. You will find information in Work Card 20-04-05-402 (MTC).

No. EC155-71A015

3.B.2.a. Removal of the aluminum stiffener from the firewall ([Figure 1](#))

Refer to DETAIL A, DETAIL C, DETAIL D and DETAIL E:

- Remove the rivets (c) from the stiffener (a). Refer to Work Card 20-03-01-102 (MTC).
- If the center rivet (d) is installed on the gusset (e) (DETAIL C):
 - . Remove the rivet (d). Refer to Work Card 20-03-01-102 (MTC).
- Remove and discard (DETAIL B):
 - . The stiffener (a)
 - . The bolts (b)
 - . The washers (j)
 - . The nuts (k).
- Remove and keep (DETAIL A, DETAIL B):
 - . The cover strip (g)
 - . The fireproof seal (h)
 - . The clamps (m).
- If the bracket (f) is in unsatisfactory condition (DETAIL D):
 - . Remove the rivet (n)
 - . Remove and discard the bracket (f).

3.B.2.b. Installation of the titanium stiffener on the firewall ([Figure 2](#))

- Put in position the stiffener (1) on the firewall to agree with the existing holes.
- If there is a hole (A) on the gusset (e) (DETAIL A):
 - . Counter-drill the hole (A) to 2.4 mm diameter on the stiffener (1).
- Counterdrill the holes (B) to 5,5 mm diameter to agree with the existing firewall holes.
- Counterdrill the holes (C) to 2,4 mm diameter to agree with the existing firewall holes.
- Deburr and apply protection with interposition sealant (11) to the holes (A), (B) and (C). Refer to Work Card 20-05-01-227 (MTC).
- If the bracket (f) is removed:
 - . Replace it with a new bracket (12) (SECTION B-B). Refer to paragraph [2.C.](#)
 - . Install the new bracket (12) on the firewall with rivets (13).
- Install all the rivets (2) on the stiffener (1), the gusset (e) and the bracket (12) or (f) with the sealing compound (14) (DETAIL A and DETAIL C). Refer to Work Card 20-03-02-401 (MTC) and Work Card 20-05-01-222 (MTC).
- Do a check of the cover strip (g) and the fireproof seal (h) to replace if necessary (SECTION B-B). Refer to Work Card 71-30-10-702 (AMM).
- Install the stiffener (1), the cover strip (g) and the seal (h) (DETAIL A, DETAIL C and SECTION B-B) with:
 - . The bolts (3)
 - . The washers (4)
 - . The nuts (5)
 - . The clamps (m) (not shown)
 - . The sealing compound (14). Refer to Work Card 20-05-01-222 (MTC).

No. EC155-71A015



CAUTION

MAKE SURE THAT THE ENGINE FIXED COWLING IS IN CONTACT WITH THE FIREPROOF SEAL (h). IF NECESSARY, ADJUST THE POSITION OF THE SEAL (h).

- Tighten the bolts (3) to the standard torque.

3.B.3. Final steps

- Clean and apply the close-up procedure to the work areas and the helicopter. Refer to Work Card 20-07-03-408 (MTC).
- Install or close all cowlings, panels, doors and items of equipment that you removed and/or opened during the preliminary steps (paragraph [3.B.1.](#) of this ALERT SERVICE BULLETIN).
- Install the cowlings and fairings. Refer to Task 53-54-00-061 (AMM).
- Remove the access equipment.
- Connect all the electrical power supplies.
- Set the helicopter to flight condition.

3.C. RECORD OF COMPLIANCE

Compliance with this document:

- Record the full compliance with this ALERT SERVICE BULLETIN, with the revision number, in the helicopter documents.
- Record the full compliance with this ALERT SERVICE BULLETIN (see IN 3785-I-00 for instructions): QR code or hypertext link



NOTE 3

The recording of compliance with ALERT SERVICE BULLETINS in the SB Insight tool does not replace the recording in the helicopter documents.

[ASB EC155-71A015](#)

Tracking of modifications in the documentation:

Record the modification 0771C59 in the helicopter documents.

Identification of modifications on equipment or parts:

Identify the parts. Refer to the table below and Work Card 20-08-05-103 (MTC).

Key Word	Former P/N	New Reference	MOD	Marking type
Firewall	365A58-1450-0702	365A58-1450-0703	0771C59	Indelible ink

3.D. OPERATING AND MAINTENANCE INSTRUCTIONS

Not applicable.

No. EC155-71A015

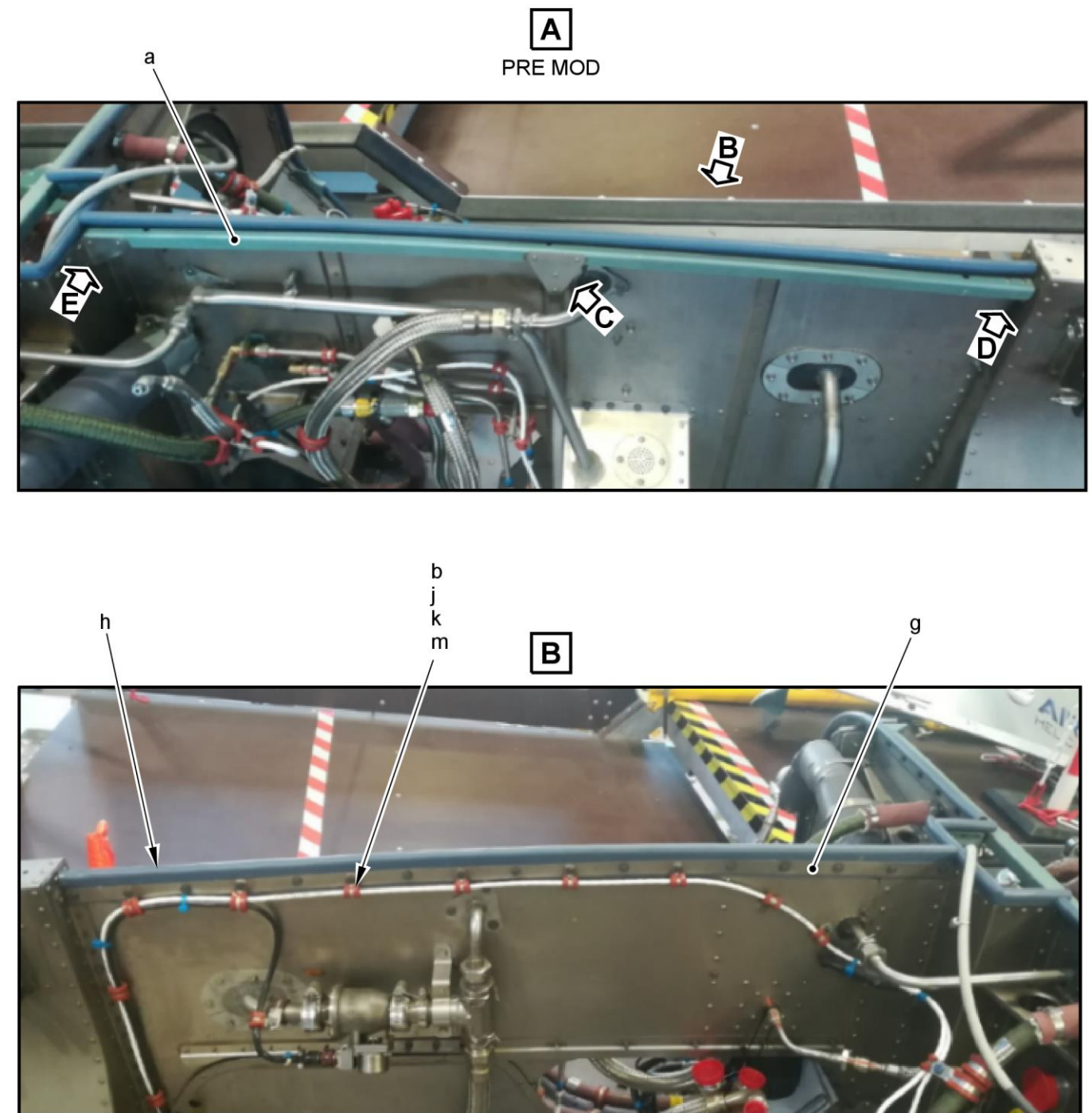
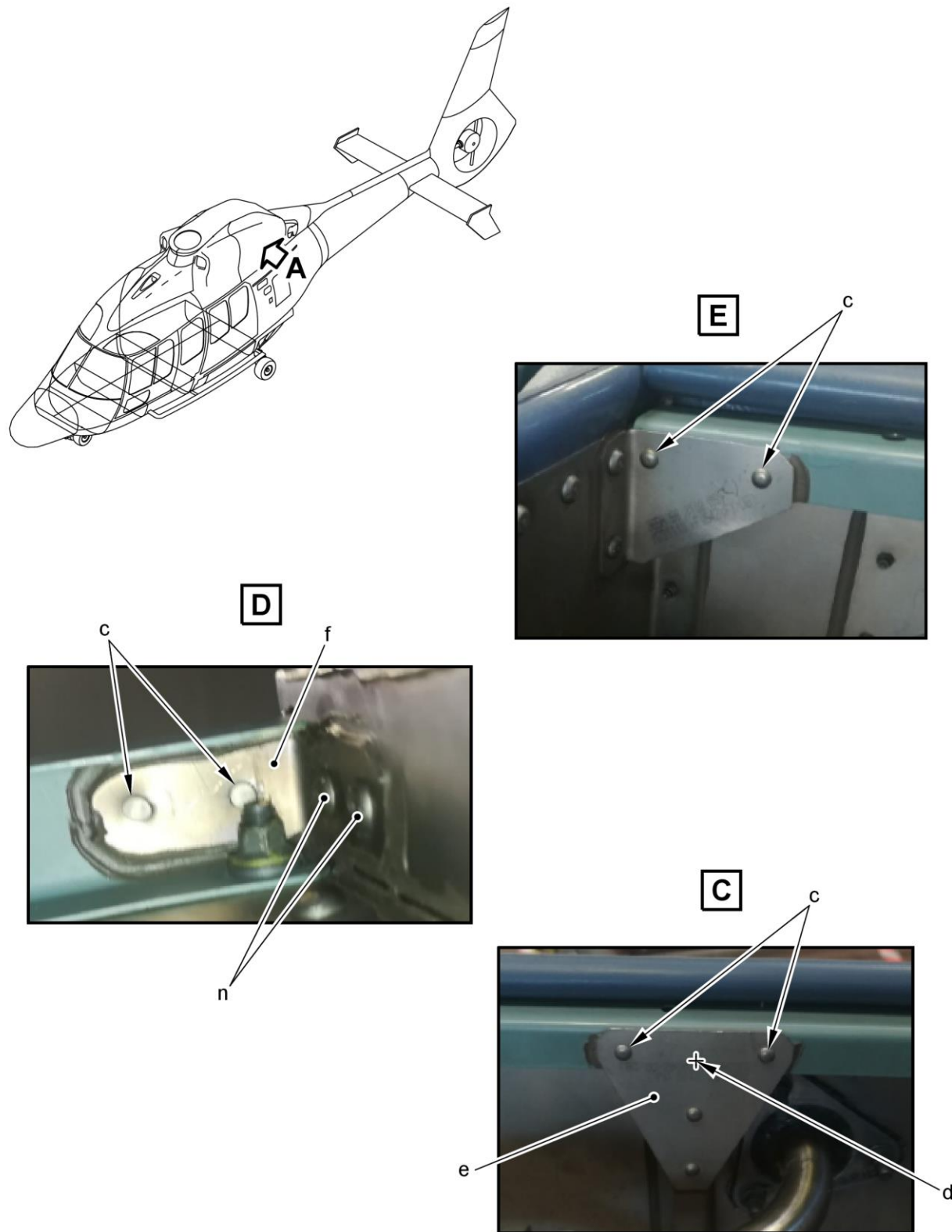

Back to paragraph [3.B.2.a.](#)

Figure 1

No. EC155-71A015

PAGE KEPT BLANK DELIBERATELY

No. EC155-71A015

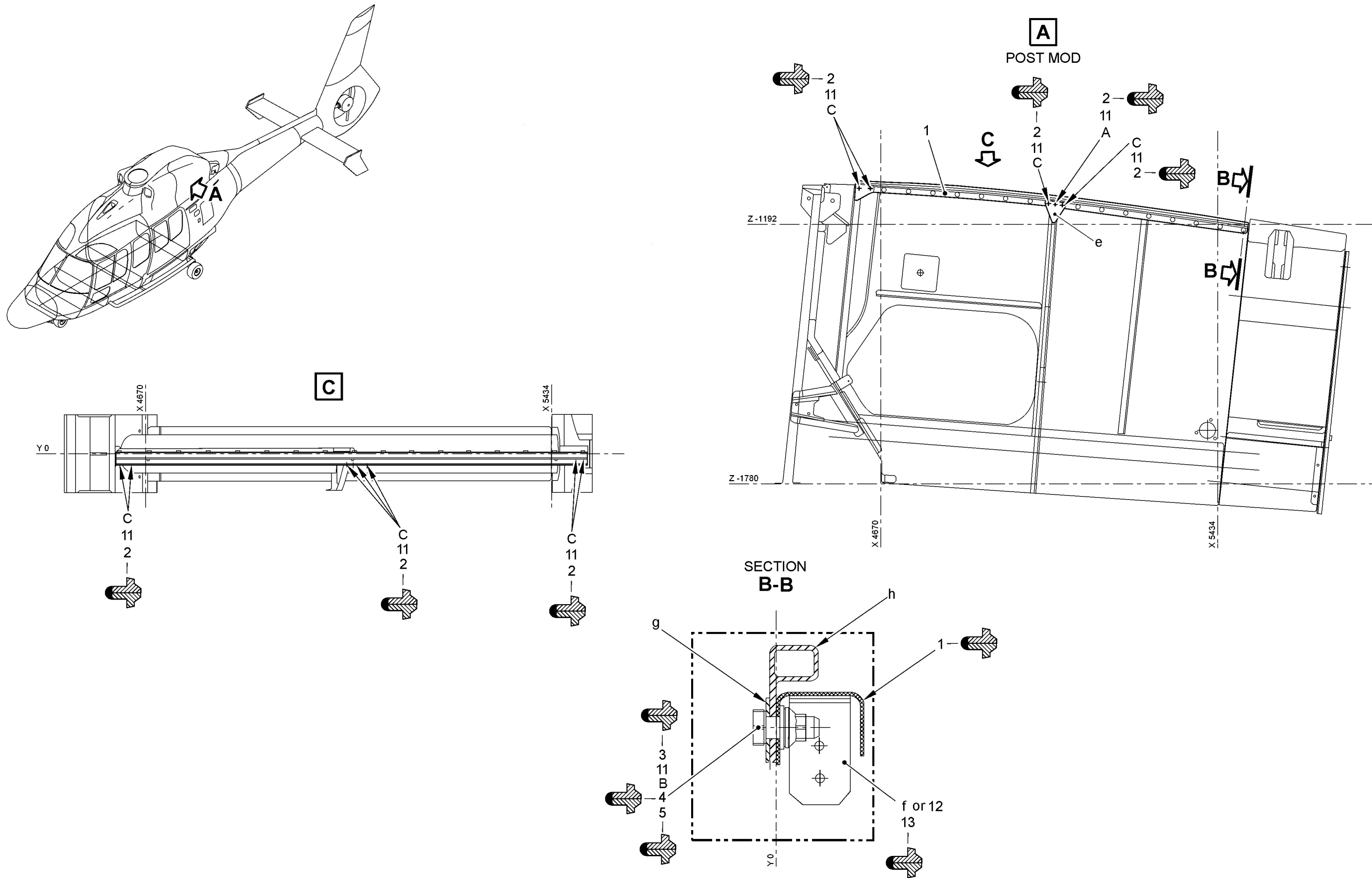

Figure 2

Back to paragraph [3.B.2.b.](#)