



No. EC155-25A160

Civil version(s): B, B1

ALERT SERVICE BULLETIN

PROTECTIVE MEASURE

EQUIPMENT AND FURNISHINGS - Main Rotor Flight Controls
Check of the shear-button safety-cap on the collective pitch handle

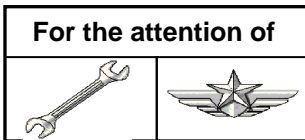
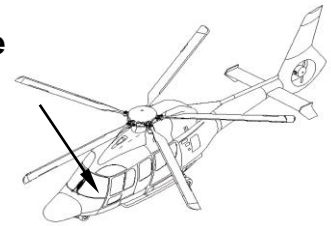

Revision No.	Date of issue
Revision 0	2022-10-04

Summary:

The purpose of this ALERT SERVICE BULLETIN is to check that the spring of the shear-button safety-cap on the collective pitch handle operates correctly.

Compliance:

It is mandatory to comply with this ALERT SERVICE BULLETIN.

No. EC155-25A160

1. PLANNING INFORMATION

1.A. EFFECTIVITY

1.A.1. Helicopters/installed equipment or parts

Helicopters EC155 versions B and B1 equipped with a hoist (removable and/or fixed parts) and that have collective pitch handle MP/N 704A41-1101-32 on pilot and co-pilot collective sticks (Figure 1).



Figure 1 - Collective pitch handle

1.A.2. Non-installed equipment or parts

- Collective sticks with collective pitch handle MP/N MP/N 704A41-1101-32.
- Collective pitch handle MP/N MP/N 704A41-1101-32.

1.B. ASSOCIATED REQUIREMENTS

Not applicable.

No. EC155-25A160

1.C. REASON

Airbus Helicopters has been informed about an unintentional activation of the hoist shear device during night flight.

During the technical investigations, it has been identified that the effect of ageing of the

shear-button safety-cap may lead to an improper functioning of the shear-button protection.

The shear-button safety-cap is fitted with a spring which is supposed to maintain the safety-cap in a frank and effective position either closed or fully open. The correct mechanical effect of the spring is to prevent the safety-cap from staying in middle position.

The purpose of this ALERT SERVICE BULLETIN is to check that the spring of the shear-button safety-cap on the collective pitch handle operates correctly.

1.D. DESCRIPTION

This ALERT SERVICE BULLETIN includes the work steps that follow:

- Do a check of the safety-caps.
- If necessary, replace the spring of the safety-caps.
- Complete and send the response form to Airbus Helicopters.

1.E. COMPLIANCE

1.E.1. Compliance at H/C manufacturer level

Not applicable.

1.E.2. Compliance in service

Helicopters/installed equipment or parts:

The operator must do the work on the helicopter.

Comply with paragraph [3](#). Refer to Table No. 1:

Table No. 1	
Helicopter configuration	Compliance time
Helicopters with hoist removable parts installed	Not more than 50 flight hours after you received the revision 0 of this ALERT SERVICE BULLETIN (refer to the issue date on the page footer).
Helicopters with only hoist fixed parts installed	Before installation of removable parts of the hoist or within 150 flight hours (the first limit you meet is applicable) after you received the revision 0 of this ALERT SERVICE BULLETIN (refer to the issue date on the page footer).

No. EC155-25A160

Interpretation of the results:

- If the safety-cap does not stay in a middle position between the open position and the closed position (Figure 2) during each step:
 - . The spring of the safety-cap on the collective pitch handle operates correctly.
 - . Do the steps in paragraph [3.B.4](#).



Figure 2 - Correct positions

- If the safety-cap stays in middle position between the open position and the closed position (Figure 3) or the safety-cap is not fully closed in closed position (Figure 3) minimum one time:
 - . The spring of the safety-cap on the collective pitch handle does not operate correctly.
 - . Replace the spring of the safety-cap within 150 flight hours following application of paragraph 3.B.2. Refer to paragraph [3.B.3](#).
 - .. Until you replace the spring of the safety-cap:
 - It is forbidden to use the hoist by night.
 - Locally make a label.
 - Attach it to the instrument panel, refer to [Appendix 4.B](#).



Figure 3 - Incorrect positions

No. EC155-25A160

Non-installed equipment or parts:

The operator must do the work on non-installed equipment.

Before you install the collective stick or collective pitch handle identified in paragraph [1.A.2.](#), do a check of the safety-cap when applicable as given in paragraph [3.B.2.](#)

Interpretation of the results:

- If the safety-cap does not stay in middle position between open and close position ([Figure 2](#)) during each step:
 - . The spring of the safety-cap on the collective pitch handle operates correctly.
 - . The collective sticks with collective pitch handle or the collective pitch handle can be installed.
- If the safety-cap stay in middle position between open and close position or if the safety-cap is not fully closed in closed position ([Figure 3](#)) minimum one time:
 - . The spring of the safety-cap on the collective pitch handle does not operate correctly.
 - . Replace the spring of the safety-cap before installation, refer to paragraph [3.B.3.](#)

1.F. APPROVAL

Approval of modifications:

Not applicable.



Approval of this document:

The technical information contained in this ALERT SERVICE BULLETIN Revision 0 was approved on October 04, 2022 under the authority of EASA Design Organization Approval No. 21J.700 for civil version helicopters subject to an Airworthiness Certificate.

1.G. MANPOWER



Airbus Helicopters recommends that the personnel who will do this ALERT SERVICE BULLETIN have this qualification:

Qualification: 1 Technician



The man-hours are an estimate given for information only and for a standard helicopter configuration.

Estimated man-hours: 10 minutes for the technician to do the check of the safety-caps.

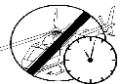

The helicopter downtime is an estimate given for information only and for a standard helicopter configuration.

The estimate of the helicopter downtime is 10 minutes (excluding time for replacement of the spring of the safety-cap).

1.H. WEIGHT AND BALANCE

Not applicable.

No. EC155-25A160

1.I. POWER CONSUMPTION

Not applicable.

1.J. SOFTWARE UPGRADES/UPDATES

Not applicable.

1.K. REFERENCES

These documents are necessary to comply with this ALERT SERVICE BULLETIN:

Standard Practices Manual (MTC):

MTC: 20-01-01-301: Use of greases - Miscellaneous products used on helicopters

MTC: 20-02-06-409: Safetying with Loctite compound - Safetying and locking assemblies

MTC: 20-07-03-406: Instructions applicable when working on an aircraft electrical circuit and power generating systems - Technical instructions

MTC: 20-07-03-408: Appearance checks on an aircraft after an inspection or repair - Technical instructions

Information Notices (IN):

IN: 3041-I-00: In need of your Technical Support? Contact us 24/7/365!

IN: 3481-I-00: The Marketplace: an AirbusWorld eOrdering service

IN: 3785-I-00: Introduction of the digital Service Bulletin reporting service SB Insight

1.L. OTHER AFFECTED PUBLICATIONS

Not applicable.

1.M. PART INTERCHANGEABILITY OR MIXABILITY

Not applicable.

No. EC155-25A160

2. EQUIPMENT OR PARTS INFORMATION

2.A. EQUIPMENT OR PARTS: PRICE - AVAILABILITY - PROCUREMENT

Price

For information about the price of the modification kits and/or components, or for aid, contact the Airbus Helicopters Network Sales and Customer Relations Department.

Availability

Contact the Sales and Customer Relations Department to know the delivery lead time.

Procurement

Send an order for the necessary quantities to the Airbus Helicopters Network Sales and Customer Relations Department:

Airbus Helicopters
Etablissement de Marignane
Direction des Ventes et Relation Client
13725 MARIIGNANE CEDEX
FRANCE

In the purchase order, write the information that follows:

- The mode of transport
- The destination
- The serial numbers of the helicopters to change.

2.B. LOGISTIC INFORMATION

Not applicable.

No. EC155-25A160

2.C. EQUIPMENT OR PARTS REQUIRED PER HELICOPTER/COMPONENT

Equipment or parts to be ordered separately:

Key Word	Qty	New P/N	Item	Old P/N →	Instruction
Spring	AR	100571	1	100571	Replace if necessary

Consumables to be ordered separately:

Refer to the Work Cards given in this ALERT SERVICE BULLETIN and list below:

Key Word	Qty	P/N	CM	Item
Locking compound	AR	ASNA-4017	621	2
Grease	AR	DCSEA354/A	115	3

You can order the consumables from the AirbusWorld Marketplace through e-ordering (IN No. 3481-I-00). If you cannot get access to e-ordering, please contact your Logistic Focal Point.

2.D. EQUIPMENT OR PARTS TO BE RETURNED

Not applicable.

No. EC155-25A160

3. ACCOMPLISHMENT INSTRUCTIONS

3.A. GENERAL

- Comply with the instructions for safetying with Loctite compound. Refer to Work Card 20-02-06-409 (MTC).
- Comply with the instruction for the use of greases. Refer to Work Card 20-01-01-301 (MTC).

3.B. WORK STEPS

Only the procedure for the left collective stick is given. Do the same procedure for the right collective stick.

3.B.1. Preliminary steps

Disconnect all the electrical power supplies. Refer to Work Card 20-07-03-406 (MTC).

No. EC155-25A160

3.B.2. Check of the correct operation of the safety-cap

NOTE 1

Correct operation:

The safety-cap has a bi-stable behavior. It can only be in the fully open or fully closed position.

- Make sure that the safety-cap (a) on the collective pitch handle (b) is in the fully closed position, refer to Figure 4.

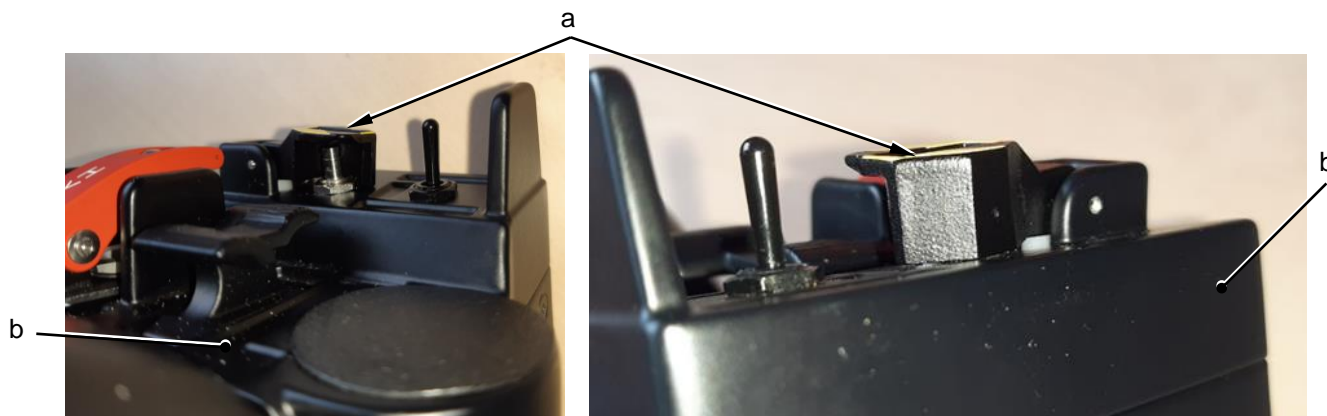

Figure 4 - Fully close position of the safety-cap

- Put the thumb below the safety-cap (a) of the collective pitch handle (b), refer to Figure 5.

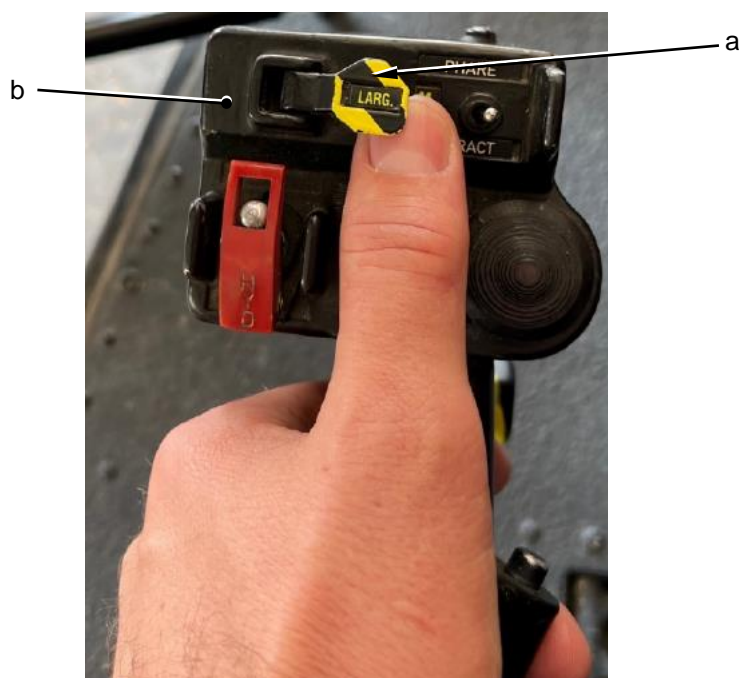

Figure 5 - Position of the thumb

No. EC155-25A160

- Do the steps that follow to do the check of the safety-cap (a):
 - . Put the thumb below the safety-cap (a).
 - . Lift the safety-cap (a) with your thumb, refer to Figure 6.
 - . Remove the thumb.
 - . Make sure that the safety-cap (a) go back to the fully closed position or move to the fully open position.
 - . If necessary close the safety-cap (a).

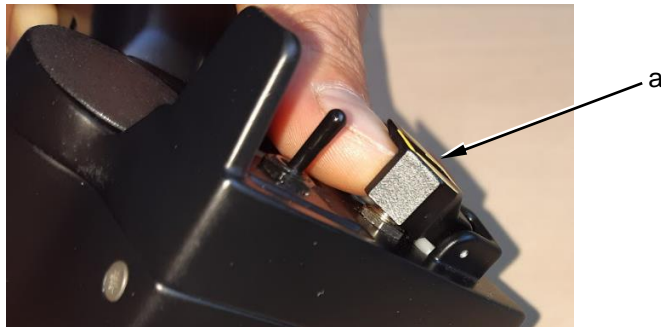

Figure 6 - Step1

- . Put the thumb below the safety-cap (a).
- . Lift the safety-cap (a) with your thumb, refer to Figure 7.
- . Remove the thumb.
- . Make sure that the safety-cap (a) goes back to the fully closed position or moves to the fully open position.
- . If necessary close the safety-cap (a).

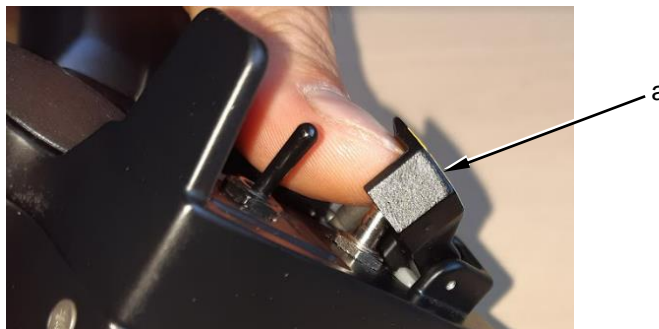

Figure 7 - Step2

No. EC155-25A160

- . Put the thumb below the safety-cap (a).
- . Lift the safety-cap (a) with your thumb, refer to Figure 8.
- . Remove the thumb.
- . Make sure that the safety-cap (a) goes back to the fully closed position or moves to the fully open position.
- . If necessary close the safety-cap (a).

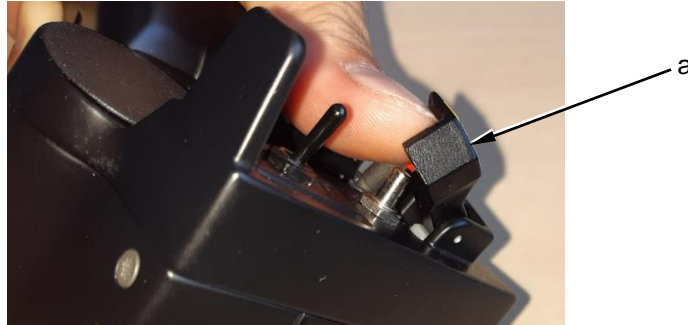

Figure 8 - Step3

- Fully open the safety-cap (a).
- Make sure that it stays in the open position.
- Close the safety-cap (a).
- Make sure that the safety-cap (a) is fully closed ([Figure 4](#))
- Do all these steps three times minimum.



NOTE 2

The video available by QR code or link below shows the essential steps of this ALERT SERVICE BULLETIN.
<https://dai.ly/k1ebJEjw0EjBEiyi8D4>

- Interpret the results, refer to paragraph [1.E.2](#).

3.B.3. Replacement of the spring of the safety-cap ([Figure 9](#) and [Figure 10](#))



CAUTION

THE SPRING (e) AND THE PUSH ROD (d) CAN BE EJECTED DURING THE REMOVAL PROCEDURE.

- Removal of the safety-cap (a):
 - . Remove the pin (c) from the collective pitch handle (b).
 - . Remove the safety-cap (a).
 - . Remove the push rod (d) and the spring (e).
 - . Discard the spring (e).

No. EC155-25A160

- Installation of the safety-cap (a):
 - . Apply grease (3) to the push rod (d).
 - . Put the new spring (1) and the push rod (d).
 - . Install the safety-cap (a) with the pin (c).
 - . Lock the pin (c) with locking compound (2).
 - . Make sure that the open and closed positions of the safety-cap (a) are correct:
 - .. Move the safety-cap (a) three times minimum.
 - .. Make sure that it is free to move.



Figure 9 - Position of the safety-cap and pin

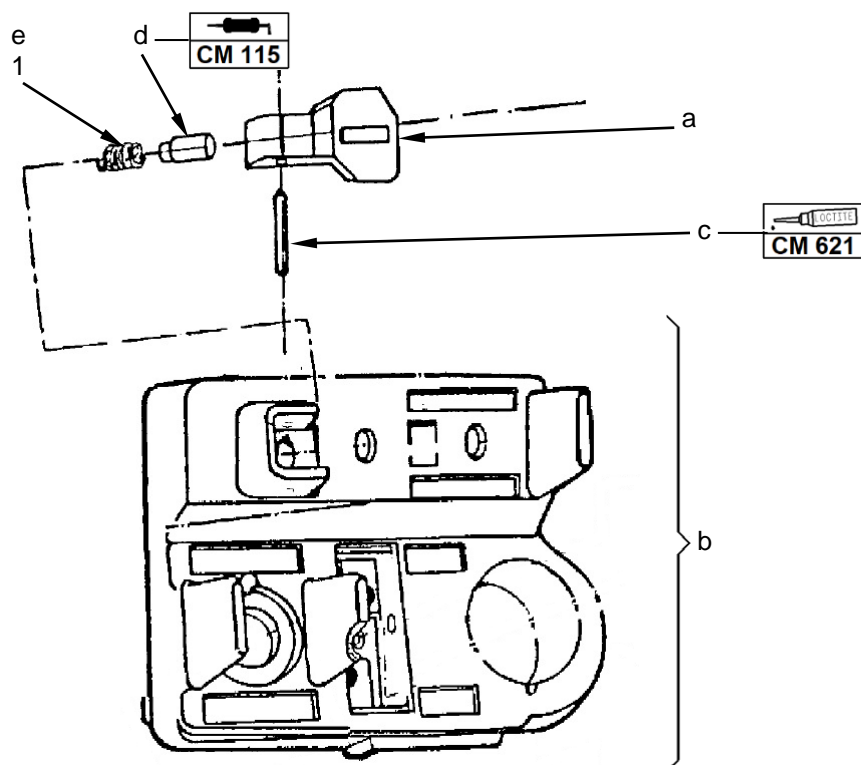

Figure 10 - Replacement of the spring of the safety-cap

No. EC155-25A160

- If installed in paragraph [1.E.2.](#), remove and discard the locally made label (h) (not shown) from the instrument panel (not shown).

3.B.4. Final steps

- Do an aspect check on the helicopter after inspection or repair, refer to Work Card 20-07-03-408 (MTC).
- Complete the response form.
- Send to Airbus Helicopters, refer to [Appendix 4.A.](#)
- Connect all the electrical power supplies, refer to Work Card 20-07-03-406 (MTC).

3.C. RECORD OF COMPLIANCE

Compliance with this document:

- Record the full compliance with this ALERT SERVICE BULLETIN, with the revision number, in the helicopter documents.
- Record compliance with this ALERT SERVICE BULLETIN (see IN 3785-I-00 for instructions):
QR code or hypertext link



NOTE 3

The recording of compliance with ALERT SERVICE BULLETIN in the SB Insight tool does not replace the recording in the helicopter documents.

[ASB EC155 25A160](#)

3.D. OPERATING AND MAINTENANCE INSTRUCTIONS

Not applicable.

No. EC155-25A160

4. APPENDIX

4.A. ALERT SERVICE BULLETIN response form

Response Form for ALERT SERVICE BULLETIN No.25A160

“Check of the shear-button safety-cap on the collective pitch handle”

Return response form on SB Insight tool when you comply with paragraph [3.C.](#) of this ALERT SERVICE BULLETIN.

In case you would not have access to the Technical Request Management, please send your response form to the following email address: customersupport.helicopters@airbus.com

This ALERT SERVICE BULLETIN response form will be used by Airbus Helicopters to define an adequate interval to integrate such safety-cap verification into the Master Servicing Manual (MSM).

Please write in e-mail title the ALERT SERVICE BULLETIN reference - ALERT SERVICE BULLETIN title - Retex

More details about Airbus Helicopters Technical Support organization and way to raise Technical Event available in IN 3041-I-00.

	SB ID Card Questionnaire Questionnaire for EC155-25A160	Page 1 of 2
<hr/>		
SB ID Card		
Title PROTECTIVE MEASURE - EQUIPMENT AND FURNISHINGS - Main Rotor Flight Controls - Check of the shear button safety cap on the handle collective pitch		
Description The purpose of this ALERT SERVICE BULLETIN is to check that the spring of the shear button safety cap on the handle collective pitch works correctly.		
<hr/>		
Compliance information		
Applied on: On aircraft		
AC S/N:	TTSN:	
<hr/>		
Questionnaire		
Did you change the spring on the pilot collective pitch grip ? *		
<input type="checkbox"/> Yes <input type="checkbox"/> No		
Part Number pilot handle collective pitch *		
.....		
.....		
Serial Number pilot handle collective pitch *		
.....		
.....		
Flight hours pilot handle collective pitch *		
..... FH (Flight Hours)		
Did you change the spring on the co-pilot collective pitch grip ? *		
<input type="checkbox"/> Yes <input type="checkbox"/> No		
Part Number copilot handle collective pitch *		
.....		
.....		
.....		

No. EC155-25A160

AIRBUS
Airbus Helicopters

SB ID Card Questionnaire
Questionnaire for EC155-25A160

Page 2 of 2

Serial Number copilot handle collective pitch *

.....
.....

Flight hours copilot handle collective pitch *

..... FH (Flight Hours)

No. EC155-25A160

4.B. Locally made label

- Characteristics of the locally made label (4) or (5):
 - Text to read: **IT IS FORBIDDEN TO USE THE HOIST BY NIGHT.**
 - Font in white color with a red background or in red color with a white background.
 - Font size more than or equal to: 4 mm (.157 in).
 - The locally made label (4) or (5) must not be easily erasable.
 - The locally made label (4) or (5) must not be easily damageable.
- Example of locally made label:

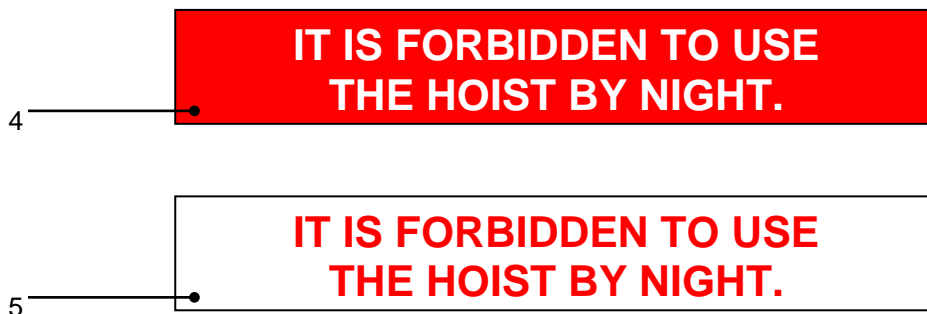

- Attach the locally made label (4) or (5) to the instrument panel (not shown) so that the limitations indicated on the locally made label (4) or (5) are visible to the pilot and the copilot.