

## Airworthiness Directive

### ▶ Federal Register Information

#### ▼ Header Information

DEPARTMENT OF TRANSPORTATION

Federal Aviation Administration

14 CFR Part 39

Amendment 39-5552; AD 87-04-19

Airworthiness Directives; EON CORPORATION: Applies to EON Corporation TSO C22 Safety Belt Assemblies Incorporating E6000 Buckle Assemblies

**PDF Copy (If Available):**

#### ▼ Preamble Information

AGENCY: Federal Aviation Administration, DOT

DATES: Effective March 18, 1987.

#### ▼ Regulatory Information

**87-04-19 EON CORPORATION:** Amendment 39-5552. Applies to EON Corporation TSO C22 safety belt assemblies incorporating E6000 buckle assemblies.

Compliance is required within 30 days after the effective date of this AD, unless previously accomplished.

To prevent inadvertent opening of safety belt assemblies, accomplish the following:

A. Inspect all EON Corporation TSO C22 safety belt assemblies to determine if they use E6000 buckle assemblies. If a safety belt assembly with E6000 buckles is installed, remove and replace it with another FAA-approved safety belt assembly. The removed belts, if not destroyed, must have the TSO approval markings either permanently obliterated or removed.

NOTE: This type of buckle assembly has a front cover plate which is pivoted at one end and is pulled at the other end through an arc to release the latch from the buckle. The E6000 buckle assemblies can be identified by the type of catch they use. Figure 1 (following) shows the configuration of the catch and how it is located within the buckle assembly.

B. Alternate means of compliance which provide an acceptable level of safety may be used when approved by the Manager, Western Aircraft Certification Office, FAA, Northwest Mountain Region.

This amendment becomes effective March 18, 1987.

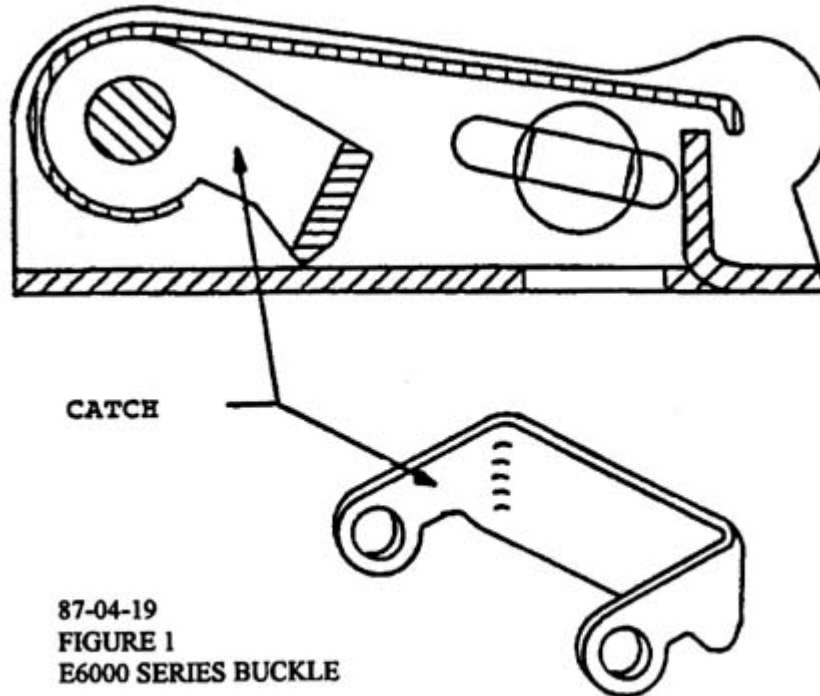

▼ Footer Information

▼ Comments

[FAA.gov Home](#) | [Privacy Policy](#) | [Web Policies & Notices](#) | [Contact Us](#) | [Help](#)

[Readers & Viewers: PDF Reader](#) | [MS Word Viewer](#) | [MS PowerPoint Viewer](#) | [MS Excel Viewer](#) | [WinZip](#)