

DOCUMENT N.

189G0000M006



ISSUE

V
TITLE MAINTENANCE REVIEW BOARD REPORT AW189 HELICOPTER
COMPILED

GIACOMO GIBILISCO	date
	14 June 2024
 Electronically approved	

SPECIALISTS

AREA APPROVAL

GIACOMO GIBILISCO	date		Luca Castaldi	date
	14 June 2024			14 June 2024
 Electronically approved			 Electronically approved	

AUTHORIZATION

GIORGIO DOSSENA	date
	14 June 2024
 Electronically approved	

VERIFICATION / AIRWORTHINESS

date	date	date	date
date	date	date	date
date	date	date	date
date	date	date	date
date	date	date	date
date	date	date	date
			Airworthiness N.A.

The document has been electronically approved.

© Copyright 2024 Leonardo S.p.a.

This document contains information that is confidential and proprietary to Leonardo S.p.a. ('the Company') and is supplied on the express condition that it may not be disclosed to any third party, or reproduced in whole or in part, or used for manufacture, or used for any purpose other than for which it is supplied, without the prior written consent of the Company. Every permitted disclosure, reproduction, adaptation or publication of this document in whole or in part and in any manner or form shall prominently contain this notice.



REVISION HISTORY

ISSUE REFERENCE	CHANGE DESCRIPTION	ISSUE DATE
A	Initial Issue	Jan 2014
B	Introduction of AW189ER (Underbelly), new kits and design improvements	Jul 2014
C	Introduction of new kits and design improvements	March 2015
D	Introduction of new kits and design improvements	September 2015
E	Introduction of new kits and design improvements	January 2016
F	Introduction of new kits and design improvements	June 2016
G	Introduction of new kits and design improvements. See detailed summary of changes	January 2017
H	Introduction of new kits and design improvements. See detailed summary of changes	July 2017
I	Introduction of new kits and design improvements. See detailed summary of changes	February 2018
J	Introduction of new kits and design improvements. See detailed summary of changes	June 2018
K	Introduction of new kits and design improvements. See detailed summary of changes	December 2018
L	Introduction of new kits and design improvements. See detailed summary of changes	June 2019
M	Introduction of new kits and design improvements. Aneto 1K ENGINE tasks added. See detailed summary of changes	December 2019
N	Introduction of new kits and design improvements. See detailed summary of changes	June 2020
O	Introduction of new kits and design improvements. See detailed summary of changes	December 2020
P	Introduction of new kits and design improvements. See detailed summary of changes	June 2021
Q	Introduction of new kits and design improvements. See detailed summary of changes	December 2021
R	Introduction of new kits and design improvements. See detailed summary of changes	June 2022
S	Introduction of new kits and design improvements. See detailed summary of changes	December 2022



ISSUE REFERENCE	CHANGE DESCRIPTION	ISSUE DATE
T	Introduction of new kits and design improvements. See detailed summary of changes	June 2023
U	Introduction of new kits and design improvements. See detailed summary of changes	December 2023
V	Introduction of new kits and design improvements. See detailed summary of changes	June 2024

**DISTRIBUTION LIST**

LEONARDO DEPT. REPRESENTATIVE EXTERNAL COMPANY	NOTES	N. COPIES
EASA MRB Chair	F. Tanzi	1
Distributed in accordance with PSE publication site policy	LHs 189 Operators	-
LHs 189 Chief Project Engineer (CPE)	G. Dossena	1
LHs SRS Office Manager	L. Castaldi	1
LHs 189 ISC Chairman, WG1/2/3/4/6 Team Leader	G. Gibilisco	1
LHs 189 Product Support Engineering (PSE)	A.Piccin; M. Modè; C. Chirullo	3
LHs 189 CPE Office / WG5 Leader	C. Rimoldi; F. Veronelli	2

© Copyright 2024 Leonardo S.p.a.

This document contains information that is confidential and proprietary to Leonardo S.p.a. ('the Company') and is supplied on the express condition that it may not be disclosed to any third party, or reproduced in whole or in part, or used for manufacture, or used for any purpose other than for which it is supplied, without the prior written consent of the Company. Every permitted disclosure, reproduction, adaptation or publication of this document in whole or in part and in any manner or form shall prominently contain this notice



TABLE OF CONTENTS

TABLE OF CONTENTS	5
APPROVAL / ACCEPTANCE LETTERS	7
EASA LETTER	8
FAA LETTER	9
TCCA LETTER	10
SUMMARY OF CHANGES	11
SECTION A - INTRODUCTION	13
1. MRB PREAMBLE	13
1.1 DESIGN STANDARD	14
2. BASIS FOR STANDARDS AND PROCEDURES	15
3. REVISION POLICY	16
4. TEMPORARY REVISION POLICY	16
5. OVERALL PROGRAMME DESCRIPTION	17
5.1 SECTION C	17
5.2 SECTION D	18
5.3 SECTION E	19
6. TASK CODES	20
7. TASKS INTERVALS	21
8. SAMPLING PROGRAMME	22
SECTION B - GENERAL RULES FOR THE USE OF THE AW189 MRBR	23
1. GENERAL RULES	23
2. INTERFACES WITH AMPI CHAPTER 4	28
3. MRBR INTERVAL NOTES	29
4. PLANNING NOTES	30
5. PERMITTED VARIATION OF TASKS FREQUENCIES	31
5.1 GENERAL RULE	31
5.2 MAXIMUM PERMITTED VARIATIONS	33
SECTION C - ROTORCRAFT SYSTEMS AND POWERPLANT	34
1. GENERAL	34
2. ROTORCRAFT SYSTEMS AND POWERPLANT SECTION RULES	34
3. EXPLANATION OF SYSTEMS AND POWERPLANT SECTION FORMAT	38
4. SAMPLING PROGRAMME	42
ROTOR AND TRANSMISSION CORROSION SAMPLING PROGRAMME	42
5. LIST OF TASKS	45
SECTION D - STRUCTURE	208
1. GENERAL	208
2. ROTORCRAFT STRUCTURE CLASSIFICATION	209
3. STRUCTURE SECTION RULES	211
4. CORROSION PREVENTION AND CONTROL PROGRAMME	213
4.1 BACKGROUND	213
4.2 MANUFACTURER BASELINE CPCP	213
4.3 OPERATOR CPCP	214
5. EXPLANATION OF STRUCTURE SECTION FORMAT	215
6. LIST OF TASK	218



SECTION E - ZONAL INSPECTIONS	255
1. GENERAL	255
2. ZONAL INSPECTIONS SECTION RULES	257
3. EXPLANATION OF ZONAL INSPECTIONS SECTION FORMAT	259
4. LIST OF TASKS	262
SECTION F - LIGHTNING/HIRF (L/HIRF) & FUEL TANK SAFETY (FTS) INTERFACES	273
1 LIGHTNING / HIRF	273
1.1 INTERNAL LINE REPLACEABLE UNIT (LRU) L/HIRF PROTECTION COMPONENTS	273
1.2 EXTERNAL ON ROTORCRAFT L/HIRF PROTECTION COMPONENTS	274
2 FUEL TANK SAFETY (FTS)	274
SECTION G - REQUIREMENTS FOR U.S. OPERATORS	275
APPENDIX 1 - AIRWORTHINESS LIMITATIONS SECTION	App 1-1
1.1 RETIREMENT LIFE	App 1-1
1.2 MANDATORY INSPECTIONS	App 1-1
1.3 CMRs	App 1-1
APPENDIX 2 ROTORCRAFT ZONES AND ACCESS	App 2-1
1. AW189	App 2-1
2. AW189ER (using "UB" suffix when different to AW189)	App 2-16
3. AW189 and AW189ER Access Panels Numbering	App 2-34
APPENDIX 3 - ADMINISTRATION	App 3-1
APPENDIX 4 - DEFINITIONS	App 4-1
APPENDIX 5 - ABBREVIATIONS	App 5-1
APPENDIX 6 - LIST OF MAINTENANCE SIGNIFICANT ITEMS (MSIs) AND STRUCTURAL SIGNIFICANT ITEMS (SSIs)	App 6-1
6.1 LIST OF MSIs	App 6-1
6.2 LIST OF non-MSIs	App 6-8
6.3 LIST OF SSIs	App 6-9
6.4 LIST OF OTHER STRUCTURE	App 6-12
6.5 LIST OF MSIs WITHOUT TASK SELECTED	App 6-15
6.6 LIST OF SSIs WITHOUT TASK SELECTED	App 6-20
6.7 LIST OF GENERAL VISUAL INSPECTIONS (GVI) SATISFIED BY ZONAL INSPECTIONS	App 6-21
6.8 LIST OF ZONES NOT COVERED BY ZONAL INSPECTIONS	App 6-23
APPENDIX 7- DELETED TASK LIST	App 7-1
APPENDIX 8 - STRUCTURAL INSPECTIONS REPORTING SYSTEM	App 8-1



APPROVAL / ACCEPTANCE LETTERS

Approval / Acceptance letters of the Document No 189G0000M006 issue V (Maintenance Review Board Report for AW189 Helicopter) are reported in the next pages.



EASA LETTER



 Ref. Ares(2024)4545026 - 24/06/2024

Raffaele Iovinella
Section Manager - Aircraft Maintenance & CAMO
Flight Standards

Leonardo S.p.A. - Helicopters
Attn: Mr Giacomo GIBILISCO
Via Giovanni Agusta, 520
21017 - Cascina Costa di Samarate (VA)
ITALY

Cologne, 21.06.2024

Subject:

EASA Approval of the Leonardo S.p.A Helicopters AW189 Maintenance Review Board (MRB) Report Issue V dated June 2024;
Reference: 189G0000M006

Dear Sir,

This report outlines the initial minimum maintenance requirements to be used in the development of an approved continuous airworthiness maintenance program for the airframe, engines, systems and components of the Leonardo S.p.A - Helicopters AW189 model aircraft.

The tasks and their frequencies listed in this report form part of the Instructions for Continued Airworthiness as required by CS-29 paragraph 29.1529 and Appendix A. The requirements in the report have been developed using Maintenance Steering Group 3 logic.

The European Aviation Safety Agency (EASA) hereby agrees that this report can be used, as a starting basis, for the continuing airworthiness management of the Leonardo S.p.A - Helicopters AW189 model aircraft according to Annex I of Commission Regulation (EU) No 1321/2014 (Part M) as amended.

The scope of this approval covers Sections A to F, Appendix 6 and Appendix 7 of the above referred document in subject.

This Leonardo S.p.A - Helicopters AW189 MRBR Issue V Approval Letter is issued under the provisions of the Technical Implementation Procedures (TIP) for Airworthiness and Environmental Certification between the Federal Aviation Administration of the United States of America and the European Aviation Safety Agency of the European Union, revision 7.

This Leonardo S.p.A. Helicopters AW189 MRBR Issue V Approval Letter is issued under the provisions of the Technical Implementation Procedures (TIP) for Airworthiness and Environmental Certification between the Government of Canada and the European Union, revision 4.

Yours Sincerely,

Raffaele Iovinella

Copy: ISC Chair: Giacomo GIBILISCO
EASA MRB Chair and Project Manager: Francesca TANZI
EASA Project Certification Manager (PCM): Jerzy-Roman GORDON
EASA Propulsion Project Certification Manager (PCM) for General Electric CT7-2E1: Angus ABRAMS
EASA Propulsion Project Certification Manager (PCM) for Safran Aneto 1K: Omiros KASTANIS



An agency of the European Union

TE.CSERV.00162-007

Postal address: Postfach 10 12 53
50452 Cologne, Germany
Visiting address: Konrad-Adenauer-Ufer 3
50668 Cologne, Germany

Tel.: +49 221 89990 4331
E-mail: raffaele.iovinella@easa.europa.eu
Web: www.easa.europa.eu
ISO 9001 Certified

Page 1 of 1

© Copyright 2024 Leonardo S.p.a.

This document contains information that is confidential and proprietary to Leonardo S.p.a. ('the Company') and is supplied on the express condition that it may not be disclosed to any third party, or reproduced in whole or in part, or used for manufacture, or used for any purpose other than for which it is supplied, without the prior written consent of the Company. Every permitted disclosure, reproduction, adaptation or publication of this document in whole or in part and in any manner or form shall prominently contain this notice



FAA LETTER

This revision of the AW189 Maintenance Review Board Report is issued under the provisions of the Technical Implementation Procedures (TIP) for Airworthiness and Environmental Certification between the Federal Aviation Administration of the United States of America and the European Aviation Safety Agency of the European Union.



TCCA LETTER

This revision of the Maintenance Review Board Report (MRBR) for AW189 helicopter is issued under the provisions of the Technical Implementation Procedures (TIP) for Airworthiness and Environmental Certification between the Government of Canada and the European Union.



SUMMARY OF CHANGES

MRBR ISSUE V

MRBR has been amended to address revision of tasks applicability for axelcut, cabin hooks on roof and to add tasks associated to MSI 95-63-00 applicable for Flotation and Liferaft kit made by DART supplier.

SECTION A

No change

SECTION B

No change

SECTION C

TASK TABLE:

REV CODE (R,N,D)	MRBR TASK REFERENCE	CHANGE DESCRIPTION
R	259300M-13	Applicability column clarified. Task applicable to any configuration installing an axelcut manual cable cutter.
R	259800M-01	Applicability column amended to include hooks installation on cabin roof when used to support lifeline.
R	956100M-02	Inteval format change from 12 MH to 1 YR
R	956100M-03	Inteval format change from 12 MH to 1 YR
N	956300M-01	New task applicable to DART Flotation kit
N	956300M-02	New task applicable to DART Flotation kit
N	956300M-03	New task applicable to DART Flotation kit
N	956300M-04	New task applicable to DART Flotation kit
N	956300M-05	New task applicable to DART Flotation with liferaft kit
N	956300M-06	New task applicable to DART Flotation kit
N	956300M-07	New task applicable to DART Flotation with liferaft kit
N	956300M-08	New task applicable to DART Flotation with liferaft kit
N	956300M-09	New task applicable to DART Flotation with liferaft kit
N	956300M-10	New task applicable to DART Flotation with liferaft kit
N	956300M-11	New task applicable to DART Flotation with liferaft kit
N	956300M-12	New task applicable to DART Flotation with liferaft kit
N	956300M-13	New task applicable to DART Flotation with liferaft kit
N	956300M-14	New task applicable to DART Flotation with liferaft kit
N	956300M-15	New task applicable to DART Flotation kit
N	956300M-16	New task applicable to DART Flotation with liferaft kit

SECTION D

TASK TABLE:

No change



SECTION E

No change

SECTION F

No change

SECTION G

No change

APPENDIXES

- Appendix 3 – Updated list of participants
- Appendix 6 – Updated list of MSI with no task selected
Updated list of GVI covered by Zonal



SECTION A - INTRODUCTION

1. MRB PREAMBLE

This report outlines the initial minimum scheduled maintenance/inspection requirements to be used in the development of an approved/accepted continuous airworthiness maintenance programme for the airframe, engines, systems and zones of the Leonardo Helicopters AW189 helicopter powered by General Electric CT7-2E1 or Safran Aneto 1K engines.

The maintenance requirements identified within this report have been developed in the frame of the AW189 Type Certification process and, together with the Airworthiness Limitations and Certification Maintenance Requirements form part of the Instructions for Continued Airworthiness as required by EASA Certification Specification CS29.1529 and CS29 Appendix A and FAA Code of Federal Regulations 14 CFR § 29.1529 and CFR § 29 Appendix A and TCCA Airworthiness Manual Chapter 529.1529 Appendix A.

This Maintenance Review Board Report, together with the Airworthiness Limitations Section plus a limited number of Maintenance Requirements derived from a different certification process and published within AMPI Chapter 5 are the basis for Operator's continuous airworthiness maintenance programme.

This MRB Report is approved by EASA and FAA and TCCA. All changes to this document must be approved by EASA, FAA and TCCA.

The responsible EASA Member State's National Authorities surveyor / FAA inspector / TCCA inspector shall ascertain that all of the applicable scheduled maintenance / inspection requirements in this report are included in the Operator's initial continuous airworthiness maintenance programme.



1.1 DESIGN STANDARD

The AW189 helicopter is a twin engine, single main rotor multi-role helicopter, designed essentially for civil applications. The helicopter includes protection for operation in an off-shore environment.

The main characteristics of the helicopter are summarised below.

- Fully articulated 5 blades main rotor with hydraulic dampers;
- Fully articulated 4 blades tail rotor with elastomeric dampers;
- General Electric CT7-2E1 or Safran Aneto 1K engines and Safran Power Unit (ex Microturbo) APU 60 Auxiliary Power Unit.
- Main Gearbox with sprag type freewheels on the engine input drives.
- Mixed construction fuselage using metallic and composite components
- Retractable wheeled landing gear, with brakes
- Mechanical Fixed Flight Control System and control rods to operate servos
- Digital Automatic Flight control System with series and parallel actuators
- Integrated avionic system with Full Glass Cockpit.

In addition this MRBR covers various design configurations (options/kits) of the helicopter, the maintenance requirements of which are identified within the applicability column.

In particular this MRBR covers the Extended Range configuration for which the applicable tasks can be found in a dedicated AW189ER applicability column.

The AW189ER is equipped with three additional transfer tanks to increase the total fuel capacity to approximately 2600 litres thus extending the helicopter range.

Within this report the terms “AW189ER”, “Underbelly Tank” and “UB” are to be considered equivalent.

Operators shall refer to the following criteria to define applicability:

- AW189 identifies the helicopters which have MSN 49XXX or 91XXX or 93XXX (MSN series 93XXX identifies AW189 with Aneto 1K engine installation).
- AW189ER identifies the helicopters which have MSN 89XXX or 92XXX

Rotorcraft Zones and Access specific to Underbelly configuration is provided in Appendix 2.2 using “UB” suffix when different to basic configuration.



2. BASIS FOR STANDARDS AND PROCEDURES

The scheduled maintenance tasks and intervals contained in this document have been developed, under the control of the Industry Steering Committee (ISC), by maintenance working groups, composed of members of the manufacturers, Operators and regulatory maintenance review board advisors (EASA, FAA, TCCA) according to recommendations of EASA Work Instruction WI.CSERV.00007 Maintenance Review Board Team and FAA Advisory Circular 121-22 Maintenance Review Board Procedures and TCCA TP13850 Civil Aviation Scheduled Maintenance Instruction Development Process Manual.

The MRB report is based on recommendations of USA Air Transport Association MSG-3 Document "Operator / Manufacturer Scheduled Maintenance Development" Revision 2011.1 plus procedures detailed in the Maintenance Review Board Policy and Procedures Handbook for the AW189 helicopter (Doc. No.: 189G0000M005) accepted by EASA and FAA.

The MRB Report has been developed assuming that the rotorcraft is operated where contamination with a salt laden atmosphere can be expected.

The AW189 MRB Report has been developed for, and is applicable to, rotorcraft flying up to 1600FH/year including low utilization.

The following assumptions have also been taken into account:

- A. Average Number of Landings per FH: 8
- B. Maximum Number of Rotor brake application per landing: 1

Regular use of the rotorcraft is assumed to be a normal operating condition. For periods of non-operation, additional instructions have to be considered in accordance with the AW189 technical publication such as parking and storage procedures.

MRBR Calendar driven tasks which are due during aircraft or component non-operation period can be performed before aircraft return to service or component re-installation (e.g. single rescue hoist kit).



3. REVISION POLICY

The effectiveness of scheduled maintenance is continuously analyzed by the manufacturer by examination of:

- Operational reliability (Reliability Control Programme);
- Corrosion Prevention and Control Programme (CPCP) performance results;
- Results of real performance of scheduled tasks (according to in service reports);
- Type design modifications

A periodic review is organized by the manufacturer to review the result of these analyses and define appropriate actions in accordance with 189G0000M005 “Maintenance Review Board Policy and Procedures Handbook” for AW 189 helicopter.

4. TEMPORARY REVISION POLICY

When there is an urgent safety or major operational issue, a Temporary Revision will be issued by the manufacturer, approved by EASA and FAA, and delivered to Operators.

The temporary revisions will be subject to a full assessment at the next periodic review following the guidelines as per Paragraph 2.3.3 of 189G0000M005 “Maintenance Review Board Policy and Procedures Handbook” for AW 189 helicopter.



5. OVERALL PROGRAMME DESCRIPTION

The maintenance tasks and their intervals are presented in the following sections:

- Systems & Powerplant / Rotor / Rotor drive system ([Section C](#))
- Structure ([Section D](#))
- Zonal Inspection ([Section E](#))

5.1 SECTION C

The Systems & Powerplant / Rotor / Rotor drive system section provides specific tasks for Maintenance Significant Items (MSI), considering their failure effects category (FEC).

Stand-alone maintenance tasks derived from the Enhanced Zonal Analysis Procedure (EZAP) and the Lightning / High Intensity Radiated Field (L/HIRF) Analysis are also shown in the System and Powerplant section under ATA Chapter 20.

Scheduled maintenance requirements related to Fuel Tank Ignition Prevention in Section C are reported with “FTS” marker in the source column and are identified within MSI 28-90-00 for AW189 and MSI 28-90-01 for AW189ER .

NOTE: FTS marker is not intended to imply a level of skill of maintenance staff required to accomplish the task.

Those MSIs with no scheduled maintenance tasks selected during MSG-3 analysis are not incorporated in the System and Powerplant section but are listed in a dedicated section of [Appendix 6](#).

The list of all MSIs is also reported under [Appendix 6](#).



5.2 SECTION D

The Structure Section defines inspections for Structural Significant Items (SSI) developed through evaluation of their Environmental Deterioration (ED) and Accidental Damage (AD) characteristics and highlights tasks related to Corrosion Prevention and Control Programme (CPCP).

Those SSIs with no scheduled maintenance tasks selected during MSG-3 analysis are not incorporated in the Structure section but are listed in a dedicated section of [Appendix 6](#).

A list of all SSIs is also reported under [Appendix 6](#).



5.3 SECTION E

The Zonal Inspections Section defines General Visual Inspections (GVI) for the zones of the rotorcraft which include system installations, structures, L/HIRF devices and EWIS.

The Zonal Inspections Section may also cover GVIs coming from analyses of MSI. The list of MSI tasks covered by zonal tasks is given in [Appendix 6](#) of this report.

All tasks related to Electrical Wiring Interconnection Systems (EWIS) requirements are derived from an Enhanced Zonal Analysis Procedure (EZAP) and are located in both Section C and Section E of the MRBR.

Scheduled maintenance requirements related to Fuel Tank Ignition Prevention in Section E are reported with “FTS” marker in the source column and are identified within MSI 28-90-00 for AW189 and MSI 28-90-01 for AW189ER .

NOTE: FTS marker is not intended to imply a level of skill of maintenance staff required to accomplish the task.



6. TASK CODES

Task codes used in this Report are presented in Table 1:

TASK TYPE	TASK CODE	TASK DESCRIPTION EXAMPLE
LUBRICATION	LU	LUBRICATION OF NOSE LANDING GEAR RETRACT ACTUATOR
SERVICING	SV	SERVICING (HYDRAULIC FLUID REPLACEMENT) OF THE HYDRAULIC SYSTEM CIRCUIT 1 AND CIRCUIT 2
OPERATIONAL CHECK	OC	OPERATIONAL CHECK OF POWER CONTROL MODULE (PCM) 1 FLIGHT CONTROL SHUT OFF VALVE
VISUAL CHECK	VC	VISUAL CHECK OF POWER CONTROL MODULE (PCM) 1 DIFFERENTIAL POP-OUT INDICATORS
GENERAL VISUAL INSPECTION	GVI	GENERAL VISUAL INSPECTION OF LOWER HALF OF FUSELAGE
DETAILED INSPECTION	DI	DETAILED INSPECTION OF CAPTAIN AND FIRST OFFICER SEATS ADJUSTMENT AND LOCKING MECHANISMS OF VERTICAL AND HORIZONTAL DIRECTION INCLUDING SEAT RETRACTION
SPECIAL DETAILED INSPECTION	SDI	SPECIAL DETAILED INSPECTION (BOROSCOPIC INSPECTION) OF COMBUSTION CHAMBER
FUNCTIONAL CHECK	FC	FUNCTIONAL CHECK (FORCE MEASUREMENT) OF THE FLYING CONTROLS MOVEMENT
RESTORATION	RST	RESTORATION (ELECTROLYTE ADJUSTMENT) OF AIRCRAFT BATTERY
DISCARD	DIS	DISCARD FIRE EXTINGUISHER CARTRIDGE

TABLE 1

Task type definitions are available in [Appendix 4](#) "Definitions".



7. TASKS INTERVALS

Periodicity of the scheduled maintenance has been established by the MSG-3 process based on the usage parameters Rotorcraft Flight Hours, Rotorcraft Landing, APU hours, APU cycles, hoist lifts, external load cycles and Calendar Time, whichever is most suitable to determine the degree of deterioration and / or technical condition of systems and airframe during rotorcraft operation.

Task interval parameters expressed in this report may be converted to individual Operator units suitable for their operation (i.e. Rotorcraft Flight Hours, Rotorcraft Landing or Calendar Time) provided this conversion does not result in the Operator exceeding the initial requirements of this report.

Although this MRBR does not contain requirements to establish packaged maintenance checks, some planning and accomplishment notes are provided in this report in accordance with definitions stated in Section B paragraph 3. All tasks have individual intervals that provide Operators with flexibility for Operator Maintenance Programme (OMP) development.

Operators are allowed to package tasks based on their real utilization provided that, this packaging does not result in the Operator exceeding the initial requirements of this report.

For utilization of permitted variation of task frequencies refer to Section B paragraph 5.

For adjustment of OMP task interval refer to Section B paragraph 1.



8. SAMPLING PROGRAMME

Sampling is an examination of a specific number of items at defined intervals in order to validate that there are no unexpected degradation characteristics.

LHs has elected to develop a sampling program for corrosion detection on some Rotor and Transmission Elements. For details refers to [Section C Paragraph 4.](#)



SECTION B - GENERAL RULES FOR THE USE OF THE AW189 MRBR

1. GENERAL RULES

For the use of all sections of this document the Operator should be guided by the following:

- 1) The reliability of the systems, equipment and rotorcraft shall be monitored by each Operator's system for continuous analysis and surveillance as required by the Operator's Regulatory Authority.
- 2) Operators whose real rotorcraft utilization exceeds 1600FH/Year, should contact Leonardo Helicopters and must adjust their Maintenance Program (as applicable) in agreement with Operator's Regulatory Authority.
- 3) Operators shall provide the manufacturer with information about failures and defects identified as a result of scheduled maintenance in accordance with requests from the manufacturer and any requirements of the Regulatory Authority. Reporting shall include when no findings or no failures are observed during scheduled maintenance.
- 4) It is the responsibility of each Operator to adjust their maintenance programme in accordance with their National Requirements, and to comply with existing rules with respect to reporting events having effects on the continued airworthiness of the rotorcraft to their Regulatory Authority and to the manufacturer.
- 5) It is the responsibility of each Operator to adjust their maintenance programme, based on in-service experience, considering specific environmental conditions such as:
 - Regular exposure to highly corrosive environment;
 - Regular exposure to sandstorms and dust;
 - Regular operations in areas of high humidity;
 - Regular operations in areas of high temperature;
 - Exposure to volcanic ash.



- 6) It is the responsibility of each Operator to adjust their maintenance programme, based on in-service experience, considering specific operations such as:
 - under slung load;
 - Emergency Medical Services (EMS)
 - Fire fighting

- 7) This MRBR is not intended to cover operational requirements (e.g water draining, de-icing, mooring) or Unscheduled Maintenance (e.g. Conditional or Opportunity Inspections). Reference to the appropriate Technical Publications, published by LHs or any System/Component OEM, has to be made.

- 8) No recommendation is made for scheduled fuel analysis. Operators who suspect the quality of their fuel supplies or who operate in an environment known to promote microbiological growth are recommended to introduce a fuel sample analysis and consider the use of additives to minimize the potential for such growth.

- 9) The individual check intervals listed in this Report may be optimized by the Operator following the completion of the required series or sequence of checks and the satisfactory review of check results and approval by the responsible National Aviation Authority (NAA), or in accordance with the operator's NAA approved reliability programme. Individual task intervals may be optimized based on satisfactory substantiation by the Operator, and review and approval by their responsible NAA or in accordance with the Operator's NAA-approved reliability programme.

NOTE

The Operator shall consider the following parameters for task interval adjustments:

- For Systems and Powerplant Section C, the Failure Effect Category (FEC);
- For Structure Section D, the CPCP reference.
- For Zonal Inspections Section E, the source column e.g. coverage of the General Visual Inspections transferred from Systems & Powerplant analysis as listed in [Appendix 6](#);



- 10) Service Bulletins (SB) implementation can impact applicability (according to rotorcraft modification) or intervals of maintenance tasks.
- 11) Within this report the terms "check" and "inspection" are not intended to imply a level of skill of maintenance staff required to accomplish the task.
- 12) Lubrication requirements specified in this report arise from the MSG–3 analysis process and do not represent the total lubrication provisions for the rotorcraft. Additional lubrication information could be contained in recommended manufacturer’s maintenance publications.
- 13) If a MRBR task is performed by flight crew according to approved operational documents, performance of such tasks conforms to the requirements of this document.
- 14) The use of Non-Destructive Inspection (NDI) methods, such as "X-ray", "ultrasonic", "eddy current", "radio isotope", etc, which are approved by the TC Holder, can provide an alternative to the methods prescribed in this Report. Each Operator should notify its National Aviation Authority of the use of an acceptable alternate method.
- 15) Those tasks for which the interval is expressed in APU Hours or Cycles, the APU Total Hours / Cycles shall be managed by the Operator and calculated using the following formula:

$$APU \text{ Total hours/Cycles } (t) = H/C \text{ APU hour/cycles counter } (t) - H/C \text{ APU hour/cycles counter } (t_0) + APU \text{ total/cycles hours } (t_0)$$

(t₀) = at time of APU installation

For brand new APU the “APU total hours/cycles (t₀)” is zero.

For first APU installation on the helicopter the “H/C APU hour counter (t₀)” is zero.



It is essential that Operators properly record the APU hour / cycles counter indication at each APU removal from the helicopter.

APU hours/cycles counter is available on the monitoring system installed on cockpit.

NOTE: It is not possible to reset the H/C APU hour/cycles counter.

As an alternative, Operators may develop conversion factors (i.e., APU hour to flight hours) with the approval of their National Aviation Authority for incorporation into their own scheduled maintenance programme, provided this conversion does not result in the Operator exceeding the initial requirements of this report.

- 16) Whenever more than one usage parameter interval is assigned to a task, and when not stated otherwise, the interval expiring first shall apply.
- 17) When a task is accomplished earlier than its due time, the subsequent due time shall be calculated starting from its actual completion.
- 18) Means of access (such as doors and panels) opened or removed during scheduled maintenance inspections, and not having a separate defined task, shall receive a General Visual Inspection together with the relevant Inspection.
- 19) Access information provided in this MRBR are normally derived from the standard configuration and constitutes the minimum requirements. The Operators shall consider additional access due to customized installations/covers.
- 20) It is the responsibility of each Operator to adjust their maintenance programme considering additional vendor recommendations related to Customer Furnished Equipment (CFE).
- 21) If the aircraft is equipped with a Polycon Radio System, whose transceivers are typically stored off-aircraft, the Operator is recommended to establish a system to monitor the Transceiver battery life.
- 22) The starting point for calculation of the due dates (T zero) or due times of all aircraft maintenance tasks are defined as follows (whether the intervals are quoted in Rotorcraft Flight Hours (FH), Rotorcraft Landing (RL) or Calendar Time):



- For Flight Hours and Landings – from First Flight as reported in the helicopter log book
- For Calendar Time – from the first aircraft run up before aircraft delivery as reported in the helicopter log book
- For Time - controlled Items (off aircraft calendar tasks which are to be controlled independently from the airframe) – The starting point will be considered as the first installation date unless otherwise specified.

NOTE: the above general guidance may be adjusted in agreement with the Competent Aviation Authority

- 23) New issues of the MRB report which introduce new tasks or change existing tasks, must be evaluated for incorporation into the operators maintenance program (OMP).

Incorporation (where required) in the OMP should be within six months of the date of receipt of the new issue of the MRB report by the operator.

After incorporation in the OMP, the new or changed task shall be accomplished at the next suitable point in that program within the frequency designated for these tasks unless otherwise specified.

NOTE: this LHs guidance does not take precedence over any applicable National Requirements or Regulations but may be adjusted in agreement with the Competent Aviation Authority.

NOTE: The guidelines herein do not apply to the intervals of tasks resulting from Airworthiness Directives (AD) or Airworthiness Limitation Section (ALS).



2. INTERFACES WITH AMPI CHAPTER 4

Hereafter are reported the general rules in relation to Air vehicle Maintenance Planning Information (AMPI) Chapter 4:

- Tasks and intervals related to CMRs, Mandatory Inspections and Retirement Life shall not be modified.

Tasks and intervals related to CMRs, Mandatory Inspections and Retirement Life are referred to in [Appendix 1](#).

Life-limited parts must be retired in accordance with the limits contained in Airworthiness Limitations Section of the engine and helicopter AMPI Ch.04.



3. MRBR INTERVAL NOTES

The purpose of the following general programme notes is to provide a single source of information that may be referenced repeatedly throughout this MRBR.

NOTE_A Refer to:

- Engine: Engine Maintenance Manual (either GE CT7-2E1 or SAFRAN Aneto-1K as applicable)
- APU: CMM

NOTE_B Depending on helicopter operating environment, utilization and in-service experience, a lower interval may be considered by the Operators.

NOTE_C Refer to Air Vehicle Maintenance Planning Information (AMPI) Chapter 4 Section 04-10



4. PLANNING NOTES

Wherever considered suitable, planning/accomplishment information are provided to the Operators by means of following specific notes reported in the task title:

- “*should be accomplished in conjunction with / before / after XXX*” : Operators are suggested to accomplish a task in conjunction with the referred task/event for economical or planning reasons.
- “*to be accomplished in conjunction with / before / after XXX*” : Operators are to accomplish a task strictly following the information provided by this note for technical reasons.
- “*off aircraft*”: a component removal from the rotorcraft is necessary to accomplish the task. Considering that in certain cases a shop visit is also necessary, the Operator should consider the opportunity of material procurement.
- “*Identical to*” : the technical content of the task is the same as another task derived from another MSG-3 analysis
- “*Credit for accomplishment can be taken from*” : Operator could take credit for accomplishment of one task from the completion of another referenced one.
- “*covered by / covers*” : the technical content of the task is covered by / covers the requirement of the referenced one



5. PERMITTED VARIATION OF TASKS FREQUENCIES

NOTE: See also [Section G](#) “Requirements for U.S. Operators”

NOTE 2: This Section B paragraph 5 does not apply to Canadian operators.

5.1 GENERAL RULE

Under normal operating conditions, an established interval for accomplishment of scheduled maintenance cannot be exceeded.

However, circumstances may exist that justify, under controlled conditions, use of a variation for a maintenance interval configurable as a onetime extension of an interval for an individual helicopter.

The variation procedure shall respect following rules:

- The Operator may vary the period described by this MRBR provided that such a variation is within the limits of subparagraph 5.2 of this section.
- A variation can be applied only when the period prescribed by this MRBR (or supporting documents when applicable) cannot be complied with due to circumstances which could not reasonably have been foreseen by the Operator or by its contracted Maintenance Organization.
- Permitted variations cannot be assumed as “maintenance planning tool”
- Permitted variations DO NOT apply to:
 - Airworthiness Directive
 - National Requirements
 - Life limited part intervals specified by a manufacturer or identified in aircraft or engine Type Certification Data Sheets
 - Interval specified in MMEL
 - Airworthiness Limitations, including CMRs
 - Discard Tasks
 - Overhaul tasks



- IGB and TGB servicing (oil replacement), ref to tasks [652100M-05](#) and [652200M-06](#)
- Following additional Tasks:
 - [259100M-02](#)
 - [259100M-03](#)
 - [259100M-04](#)
 - [259100M-11](#)
 - [259100M-12](#)
 - [259100M-18](#)
 - [259100M-19](#)
 - [259200M-03](#)
 - [259200M-05](#)
 - [259300M-02](#)
 - [259300M-03](#)
 - [259300M-04](#)
 - [259300M-11](#)
 - [259300M-18](#)
 - [259300M-19](#)
 - [259300M-20](#)
- When a permitted variation is used, it is non-cumulative, therefore the subsequent interval shall be computed as per the original scheduled interval (and related variation).

Examples:

- *Task interval: 100 FH. Maximum variation: 10 FH. If the task is conducted at 105 FH, the subsequent task must be performed as per original schedule at 200 FH (+ 10 FH)*
 - *Task interval: 24 months. Maximum variation: 30 days. If the task is conducted at 25 months, the subsequent task must be performed as per original schedule at 48 months (+ 30 days).*
- Variations greater than permitted intervals shall have prior approval of National Aviation Authority



5.2 MAXIMUM PERMITTED VARIATIONS

The maximum permitted variations are indicated below:

a. Items Controlled by Flying Hours

<u>Period Involved</u>	<u>Maximum Variation of Prescribed Period</u>
Up to (and including) 400 FH	+ 10%
More than 400 FH	+ 50 FH

b. Items Controlled by Calendar Time

<u>Period Involved</u>	<u>Maximum Variation of Prescribed Period</u>
Below 60 days	+ 10%
More than 60 days (included) up to 12 months	+ 6 days
More than 12 months (included)	+ 1 month

c. Item Controlled by APU HRS and CYCLE

<u>Period Involved</u>	<u>Maximum Variation of Prescribed Period</u>
Up to (and including) 400 APU Hours/ Cycles	+ 10%
More than 400 APU Hours / Cycles	+ 40 APU Hours / Cycles

d. Items Controlled by More than one limit

For items controlled by more than 1 limit, i.e. items controlled by flying hours and calendar time, the more restrictive limit shall be applied.



SECTION C - ROTORCRAFT SYSTEMS AND POWERPLANT

1. GENERAL

This section covers all rotorcraft systems, rotor drive system, powerplant and APU.

The specific tasks resulting from the supplementary Rotor/Rotor Drive System (RDSI) are also reported in this section.

In addition specific stand-alone tasks resulting from the Enhanced Zonal Analysis Procedure (EZAP) and the L/HIRF Analysis are shown in ATA Chapter 20 of this section. Information concerning L/HIRF and interface with fuel tank safety (FTS) / fuel tank ignition prevention can be found in Section F.

2. ROTORCRAFT SYSTEMS AND POWERPLANT SECTION RULES

- 1) This process does not specifically include detailed shop maintenance procedures. Off-aircraft detailed procedures are controlled by individual operators and are in accordance with the manufacturer's Instructions for Continued Airworthiness.
- 2) Operators should take the opportunity during Engine / APU removals and disassembly to perform off-aircraft inspections and parts / assembly restoration, according to the intervals established by the Engine / APU manufacturer, as per Engine Shop and Maintenance Manuals.
- 3) Operators are recommended to add in their OMP a Visual Check (VC) – i.e. failure finding task with a lesser intensity than a GVI - to be performed as a routine task within the following zones:
 - Zone 450; access panel 451A
 - Zone 461; access panel 461A
 - Zone 463; access panel 463A

This additional recommended Visual Check will have the aim of:

- Checking hydraulic fluid level;
- Verifying system (e.g. hydraulic, fuel, engine, etc.) pop-out indicators status;
- Absence of major leaks, complete failure or obvious damage in visible areas,

The Visual Check frequency can be initially established at 50FH/bi-weekly and then adjusted by Operators according to their own experience/findings.



For engine oil level check refer to recommendations within Engine Maintenance Manual. In case of particular engine operating conditions (e.g. salt laden, erosive) additional or more frequent tasks may be required according to recommendations in Engine Maintenance Manual.

For engine erosive environment refer to definition contained in SAFRAN letter 2731/09.

- 4) Torque Check requirements specified in this report arise from the MSG-3 analysis process and do not represent the total torque check provisions for the rotorcraft. Operators are recommended to consider additional torque check information provided in manufacturer’s maintenance publications, such as Main and Tail Rotor Head re-torque check within 5 to 10 flight hours after component installation.

- 5) Systems and Powerplant information provided in this section is presented in sequence / order by ATA assigned subject numbers. The list of ATA Specification 2200 assigned subject numbers / titles is provided in Table 2:

ATA	DESCRIPTION
18	VIBRATION AND NOISE ANALYSIS & ATTENUATION
20	STANDARD PRACTICE – AIRFRAME (EWIS, L/HIRF)
21	AIR CONDITIONING
22	AUTO FLIGHT
23	COMMUNICATIONS
24	ELECTRICAL POWER
25	EQUIPMENT & FURNISHING
26	FIRE PROTECTION
28	FUEL
29	HYDRAULIC POWER
30	ICE AND RAIN PROTECTION
31	INDICATING / RECORDING SYSTEMS
32	LANDING GEAR
33	LIGHTS
34	NAVIGATION
35	OXYGEN
46	SYSTEMS INTEGRATION AND DISPLAY
49	AIRBORNE AUXILIARY POWER
52	DOORS
53	FUSELAGE



ATA	DESCRIPTION
55	STABILISER
56	WINDOWS AND CANOPIES
62	MAIN ROTOR
63	MAIN ROTOR DRIVE
64	TAIL ROTOR
65	TAIL ROTOR DRIVE
67	ROTOR FLIGHT CONTROLS
71	POWER PLANT INSTALLATION
72	ENGINES
73	ENGINE FUEL AND CONTROL
74	IGNITION
75	AIR
76	ENGINE CONTROLS
77	ENGINE INDICATING
78	EXHAUST
79	OIL
93	SURVEILLANCE
95	CREW ESCAPE AND SAFETY
97	IMAGE RECORDING

TABLE 2

- 6) All MSIs as listed in [Appendix 6](#) of this report have been subjected to the MSG-3 analysis; this process has resulted in the identification of maintenance tasks which are contained in this section.
Those MSIs for which a task was not generated during the analysis are identified in [Appendix 6](#).
- 7) MSG-3 analysis allocates scheduled maintenance tasks against Failure Effect Categories (FEC), depending on the consequence of failure.
- 8) Scheduled maintenance tasks derived from MSG-3 analysis and subsequently transferred to the Zonal Inspections Section are listed, by ATA Chapter, in [Appendix 6](#).
- 9) Tasks arising from the Enhanced Zonal Analysis Procedure (EZAP), which are not consolidated in the Zonal Inspections Section are included within ATA chapter 20 of this section and have no Failure Effect Category quoted.



- 10) For tasks pertaining to Rotor and Rotor Drive System (ATA 62, ATA, 63, ATA 64 and ATA 65) refer also to Section D Paragraph 3.2, 3.3 and 3.4.



3. EXPLANATION OF SYSTEMS AND POWERPLANT SECTION FORMAT

Detailed information concerning the format of the tasks is presented in Table 3.

REVISION STATUS	MRBR TASK NUMBER	TASK CODE	TASK TITLE	SOURCE	INTERVAL	SAMPLING	FEC	APPLICABILITY	ZONE	ACCESS & REMARKS
1	2	3	4	5	6	7	8	9	10	11

TABLE 3

1 – This column shows the revision status of each MRB Report Task as follows:

- N: New Item
- R: Revised Item
- D: Deleted Item
- “(blank): Unchanged Item

In the first issue of the approved MRB Report this column will be blank. Revision status references will be added at subsequent revisions.

2 – This column indicates the MRBR task reference, e.g. 293201M-01. It is composed of 10 characters as follows:

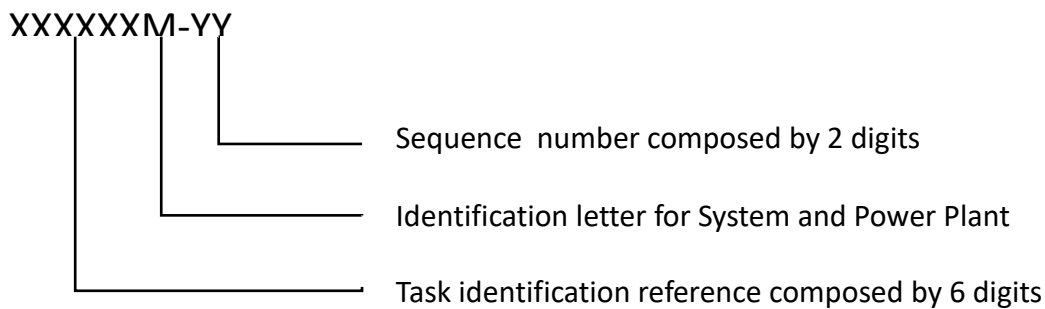

- For tasks derived from System and Powerplant analysis, task identification coincides with the MSI number.



- For stand-alone tasks established by Enhanced Zonal Analysis Procedure, task identification is made up of 6 digits (first 3 digits 201 – identification of EZAP related task, second 3 digits – reference to relevant zone number) plus 2 digits sequentially generated (i.e. 201ZZZM-0X).
- For stand-alone tasks established by L/HIRF Analysis Procedure, task identification is made up of 6 digits (first 3 digits 202 – identification of L/HIRF related task, second 3 digits – reference to relevant zone number) plus 2 digits sequentially generated (i.e. 202ZZZM-0X).

3 – This column identifies the task code according to Table 1.

4 – This column identifies the MSI title and the description of each task identified through the MRB report development process.

If the wording “NOTE” is used in other columns its explanation is reported in this column.

5– This column specifies the source for task selection, following codes are used:

- MSI, for tasks resulting from MSI analysis
- RDSI (AD), for tasks resulting from accidental damage (AD) analysis during supplemental RDSI analysis. For the objective of AD inspection, refer to Section D
- RDSI (ED), for tasks resulting from environmental deterioration (ED) and fretting corrosion analysis during supplemental RDSI analysis. For the objective of ED inspection, refer to Section D
- CPCP, for the objective of this source, refer to Section D
- EZAP, for stand-alone tasks resulting from Enhanced Zonal Analysis
- L/HIRF , for stand-alone tasks resulting from L/HIRF Analysis
- FTS, for tasks related to Fuel Tank Safety (MSI 28-90-00, MSI 28-90-01)

Multiple sources are referred when applicable.



6 – This column specifies the task interval in terms of Rotorcraft Flight Hours (FH), Rotorcraft Landing (RL), APU Hours (APU_HR), APU Cycles (APU_C), hoist lifts, external load cycles, or Calendar Time as applicable

The Calendar Time is represented by means of following measure units:

- DY = Days
- MH = Months
- YR = Years

The calendar interval is expressed using the highest available measure unit, for example:

- 12 MH is indicated as 1YR
- 18 MH remains unchanged.

The meaning of MRBR Interval notes, such as NOTE_A, is provided in section B.

Whenever more than one usage parameter interval is assigned to a task, and when not stated otherwise, the interval expiring first shall apply

7 - This Column specifies if a sampling requirement is applicable and provides associated interval in terms of Rotorcraft Flight Hours (FH), Rotorcraft Landing (RL), APU Hours (APU_HR), APU Cycles (APU_C) or Calendar Time as applicable.

Sampling Program is described [Section C Paragraph 4.](#)

When no Sampling Inspection is required, hyphens (“-”) are placed in this column.

8 – This column identifies the Failure Effect Category (FEC) of the task resulting from the MSI analysis depending on the consequence of failure, hereafter the codes used:

- FEC 5: Evident Safety Effects
- FEC 6: Evident Operational Effects
- FEC 7: Evident Economic Effects
- FEC 8: Hidden Safety Effects
- FEC 9: Hidden Non-Safety Effects

If multiple FECs have been identified for one task in the MSG-3 Analysis, all of them are indicated in this column. For stand-alone tasks identified during EZAP or L/HIRF analysis, hyphens (“-”) are placed in this column



9 – Applicability information is presented in 2 sub-columns, one for the AW189 and the other for AW189ER (for definition refer to Section A Para 1.1)

These applicability columns indicate the rotorcraft type and modification status, as necessary, to which the task is applicable.

Here after some examples of applicability information which might be provided for each sub-column:

- “YES”
- “NO”
- “with Rotor Brake kit ”;
- “S/N from xxxx to xxxx
- “post SB xxxx”
- “with CT7-2E1 engine installation”
- “with Aneto-1K engine installation”
- Others as applicable

10 – This column reports the zone(s) reference for stand-alone EWIS, L/HIRF and RDSI tasks. Other tasks will not have a zonal reference.

11 – This column reports information about access, removal or disassembly requirements for stand-alone EWIS, L/HIRF and RDSI tasks. Other tasks will not have access and remarks reference



4. SAMPLING PROGRAMME

ROTOR AND TRANSMISSION CORROSION SAMPLING PROGRAMME

Sampling requirement applies to the following tasks:

ATA 62

- [621000M-05](#)
- [622000M-06](#)
- [622000M-14](#)
- [622000M-17](#)
- [623000M-02](#)

ATA 63

- [632000M-07](#)

ATA 64

- [641000M-07](#)
- [642000M-03](#)
- [642000M-08](#)
- [643000M-03](#)
- [643000M-11](#)

ATA 65

- [651000M-12](#)
- [651000M-05](#)
- [652200M-12](#)
- [652200M-07](#)
- [652100M-06](#)



4.1.1 ROTOR AND TRANSMISSION CORROSION SAMPLING PROGRAM RULES

1. Determination of Operator Sample:

For each operator the sample size will consist of oldest aircraft(s) in the fleet in accordance with the below table.

The oldest aircraft are defined as the aircraft with the highest age in years since their initial manufacturer’s delivery date.

SAMPLE SIZE DETERMINATION TABLE

Operator H/C Fleet	Sample Size
1	1
2	1
3	1
4	1
5	2
6	2
7	2
8	2
9	3
10	3
11	3
12	3
13	4
14	4
15	4
16	4
17	4
18	5
19	5
20	5
21	5
22	5
23	5
24	5
25	6
26	6
27	6
28	6
29	6
30	6

NOTE: If the H/C number in the fleet is greater than 30 than the following formula applies:

Sample Size = 10*0.30+ 10*0.20 +[(N-20)*0.10]

Where N = Number of H/C in the Fleet

If the number of aircraft selected is not a whole number, the sample size must be corrected to the nearest whole number.



NOTE: If the operational conditions within an operator's fleet differ significantly (e.g. a sub-fleet is permanently based in a different climate condition) it is recommended to consider dedicated sample for this sub-fleet.

2. Any significant changes to an operators fleet, including buying and/or selling aircraft and retiring aircraft from the fleet, will require a review of the Sample.
3. When additional aircraft is included in the Sample, no retroactive maintenance is required i.e. all inspections are to be performed at their next due date according to the Sampling Intervals.
4. An aircraft which may be in the fleet for a limited time (e.g. less than 1 YR) should not be selected as Sample Candidate.
5. After each Sampling Inspection (with/without Finding) a Sampling Report shall be sent to AW. See [Appendix 8](#).
6. Sampling program applies to all operators World-wide.
Sampling Interval is included into the List of Tasks (paragraph 5).
7. Sampling will no longer be required (and will be removed from the MRBR) after availability and assessment of additional LH engineering data or after assessment of sampling data by LH (and manufacturer baseline CPCP adjustment) over a maximum of 8 years period (starting from the first entry into service), whichever occurs first.
8. In order to collect service feedback on execution of the aforementioned sampling tasks, a suitable table with limited number of parameters (e.g. H/C tail number, FH, landing, task execution outcome including "no finding") is available on LEONARDO Customer Website Portal and must be provided to Leonardo Product Support.



5. LIST OF TASKS

REVISION STATUS	MRB-R TASK NUMBER	TASK CODE	TASK TITLE	SOURCE	INTERVAL	SAMPLING	FEC	APPLICABILITY		ZONE	ACCESS & REMARKS
								AW189	AW189ER		
ATA 18 – VIBRATION AND NOISE ANALYSIS & ATTENUATION											
MSI 18-61-00: PASSIVE ATTENUATION UNDERBELLY TANK											
	186100M-01	GVI	GENERAL VISUAL INSPECTION OF PASSIVE VIBRATION ABSORBER (PVA)	MSI	3200 FH ; 4 YR	-	9	NO	YES	-	-
	186100M-02	GVI	GENERAL VISUAL INSPECTION OF AFT PASSIVE VIBRATION ABSORBER (PVA)	MSI	3200 FH ; 4 YR	-	9	NO	WITH AFT PVA KIT	-	-
MSI 18-62-00: MAST VIBRATION ABSORBER KIT											
	186200M-01	-	TASK DELETED WITH MRBR ISSUE E	-	-	-	-	-	-	-	-
	186200M-02	DI	DETAILED INSPECTION OF MAST VIBRATION ABSORBER INSTALLATION COMPONENTS	MSI	400 FH	-	6	WITH MAST VIBRATION ABSORBER KIT	WITH MAST VIBRATION ABSORBER KIT	-	-
	186200M-03	DIS	DISCARD OF THE MAST VIBRATION ROD ASSEMBLY	MSI	1770 FH	-	6	WITH MAST VIBRATION ABSORBER KIT	WITH MAST VIBRATION ABSORBER KIT	-	-
ATA 20 – STANDARD PRACTICE – AIRFRAME (EWIS, L/HIRF)											
STAND-ALONE TASKS GENERATED BY EWIS											

© Copyright 2024 Leonardo S.p.a.

This document contains information that is confidential and proprietary to Leonardo S.p.a. ('the Company') and is supplied on the express condition that it may not be disclosed to any third party, or reproduced in whole or in part, or used for manufacture, or used for any purpose other than for which it is supplied, without the prior written consent of the Company. Every permitted disclosure, reproduction, adaptation or publication of this document in whole or in part and in any manner or form shall prominently contain this notice



AW189 Maintenance Review Board Report

189G0000M006

Issue V

Page 46 of 275

REVISION STATUS	MRB-R TASK NUMBER	TASK CODE	TASK TITLE	SOURCE	INTERVAL	SAMPLING	FEC	APPLICABILITY		ZONE	ACCESS & REMARKS
								AW189	AW189ER		
	201111M-01	RST	RESTORATION (CLEANING ONLY IF CONTAMINATED) OF EWIS IN THE LH/RH NOSE AVIONICS BAYS, IN THE LH/RH LOWER NOSE AND IN THE NOSE FAIRING COMPARTMENT	EZAP	1 YR	-	-	YES	YES	111 ; 112 ; 114 ; 115 ; 116	ACCESS: 111A ; LH/RH LOWER NOSE ACCESS PANELS
	201111M-02	GVI	GENERAL VISUAL INSPECTION OF HIGH ENERGY EWIS (115VAC) IN THE LH/RH NOSE AVIONICS BAYS AND IN THE NOSE FAIRING COMPARTMENT (INTERNAL)	EZAP	2 YR	-	-	YES	YES	114 ; 115 ; 116	ACCESS: 111A
	201113M-01	RST	RESTORATION (CLEANING ONLY IF CONTAMINATED) OF EWIS IN THE NOSE LANDING GEAR COMPARTMENT NOTE: SHOULD BE ACCOMPLISHED IN CONJUNCTION WITH 201124M-01	EZAP	1 YR	-	-	YES	YES	113	ACCESS: NLG EXTENDED ; NLG DOORS (IF INSTALLED)

© Copyright 2024 Leonardo S.p.a.

This document contains information that is confidential and proprietary to Leonardo S.p.a. ('the Company') and is supplied on the express condition that it may not be disclosed to any third party, or reproduced in whole or in part, or used for manufacture, or used for any purpose other than for which it is supplied, without the prior written consent of the Company. Every permitted disclosure, reproduction, adaptation or publication of this document in whole or in part and in any manner or form shall prominently contain this notice



AW189 Maintenance Review Board Report

189G0000M006

Issue V

Page 47 of 275

REVISION STATUS	MRB-R TASK NUMBER	TASK CODE	TASK TITLE	SOURCE	INTERVAL	SAMPLING	FEC	APPLICABILITY		ZONE	ACCESS & REMARKS
								AW189	AW189ER		
	201121M-01	GVI	GENERAL VISUAL INSPECTION OF EWIS IN THE COCKPIT LOWER FUSELAGE AND IN THE DUCTS OF THE NOSE LANDING GEAR RETRACTION ACTUATOR COMPARTMENT (INTERNAL) ACCESS NOTE: REMOVE THE STARBOARD AND PORT FORWARD FLOATATION ASSEMBLIES INSTEAD OF PANELS 121A AND 126A IF THE FLOATATION KIT IS INSTALLED	EZAP	8 YR	-	-	YES	NO	121 ; 122 ; 123 ; 124	ACCESS: 121A ; 122A ; 123A ; 124A ; 125A ; 126A ; NOTE

© Copyright 2024 Leonardo S.p.a.

This document contains information that is confidential and proprietary to Leonardo S.p.a. ('the Company') and is supplied on the express condition that it may not be disclosed to any third party, or reproduced in whole or in part, or used for manufacture, or used for any purpose other than for which it is supplied, without the prior written consent of the Company. Every permitted disclosure, reproduction, adaptation or publication of this document in whole or in part and in any manner or form shall prominently contain this notice



AW189 Maintenance Review Board Report

189G0000M006

Issue V

Page 48 of 275

REVISION STATUS	MRB-R TASK NUMBER	TASK CODE	TASK TITLE	SOURCE	INTERVAL	SAMPLING	FEC	APPLICABILITY		ZONE	ACCESS & REMARKS
								AW189	AW189ER		
	201121M-02	GVI	GENERAL VISUAL INSPECTION OF EWIS IN THE COCKPIT LOWER FUSELAGE AND IN THE DUCTS OF THE NOSE LANDING GEAR RETRACTION ACTUATOR COMPARTMENT (INTERNAL) ACCESS NOTE: REMOVE THE STARBOARD AND PORT FORWARD FLOATATION ASSEMBLIES INSTEAD OF PANELS 121A AND 126A IF THE FLOATATION KIT IS INSTALLED	EZAP	8 YR	-	-	NO	YES	121UB ; 122UB ; 123UB ; 124	ACCESS: 121A ; 122A ; 123A ; 124A ; 125A ; 126A ; NOTE
	201124M-01	RST	RESTORATION (CLEANING ONLY IF CONTAMINATED) OF EWIS IN THE NOSE LANDING GEAR (NLG) RETRACTION ACTUATOR COMPARTMENT NOTE: SHOULD BE ACCOMPLISHED IN CONJUNCTION WITH 201113M-01	EZAP	1 YR	-	-	YES	YES	124	ACCESS: NLG COMPARTMENT, NLG EXTENDED

© Copyright 2024 Leonardo S.p.a.

This document contains information that is confidential and proprietary to Leonardo S.p.a. ('the Company') and is supplied on the express condition that it may not be disclosed to any third party, or reproduced in whole or in part, or used for manufacture, or used for any purpose other than for which it is supplied, without the prior written consent of the Company. Every permitted disclosure, reproduction, adaptation or publication of this document in whole or in part and in any manner or form shall prominently contain this notice



AW189 Maintenance Review Board Report

189G0000M006

Issue V

Page 49 of 275

REVISION STATUS	MRB-R TASK NUMBER	TASK CODE	TASK TITLE	SOURCE	INTERVAL	SAMPLING	FEC	APPLICABILITY		ZONE	ACCESS & REMARKS
								AW189	AW189ER		
	201125M-01	GVI	GENERAL VISUAL INSPECTION OF EWIS IN THE COCKPIT UNDERBELLY FUSELAGE (INTERNAL)	EZAP	4 YR	-	-	NO	YES	128UB	ACCESS: 129A ; 129B
	201130M-01	GVI	GENERAL VISUAL INSPECTION OF EWIS IN THE CENTER FORWARD CABIN LOWER FUSELAGE AND IN THE LEFT AND RIGHT CENTER CABIN LOWER FUSELAGE (INTERNAL)	EZAP ; L/HIRF ; FTS	4 YR	-	-	YES	NO	132 ; 134 ; 141 ; 145 ; 146	ACCESS: 141A ; 142A ; 221A ; 222A ; 223A ; 134A ; 145D (IF INSTALLED) REMOVAL: CABIN SEATS
	201131M-01	GVI	GENERAL VISUAL INSPECTION OF EWIS IN THE LOWER AND UNDERBELLY FUSELAGE SIDES (INTERNAL)	EZAP	4 YR	-	-	NO	YES	136UB ; 137UB ; 146UB	ACCESS: 221C ; 221G ; 136A ; 146A ; 146B ; 137A ; 145A ; 145B
	201134M-01	GVI	GENERAL VISUAL INSPECTION OF EWIS IN THE CENTRE CABIN LOWER FUSELAGE (INTERNAL)	EZAP	4 YR	-	-	NO	YES	134UB ; 143UB	ACCESS: 221E ; 222D ; 223E REMOVAL: CABIN SEAT
	201135M-01	GVI	GENERAL VISUAL INSPECTION OF EWIS IN THE UNDERBELLY FUEL TANK COMPARTMENTS (INTERNAL)	EZAP ; FTS	4 YR	-	-	NO	YES	135UB ; 138UB ; 139UB	ACCESS: 139A ; 147A ; 138A ; 148A ; 135A ; 149B

© Copyright 2024 Leonardo S.p.a.

This document contains information that is confidential and proprietary to Leonardo S.p.a. ('the Company') and is supplied on the express condition that it may not be disclosed to any third party, or reproduced in whole or in part, or used for manufacture, or used for any purpose other than for which it is supplied, without the prior written consent of the Company. Every permitted disclosure, reproduction, adaptation or publication of this document in whole or in part and in any manner or form shall prominently contain this notice



AW189 Maintenance Review Board Report

189G0000M006

Issue V

Page 50 of 275

REVISION STATUS	MRB-R TASK NUMBER	TASK CODE	TASK TITLE	SOURCE	INTERVAL	SAMPLING	FEC	APPLICABILITY		ZONE	ACCESS & REMARKS
								AW189	AW189ER		
	201147M-01	GVI	GENERAL VISUAL INSPECTION OF EWIS IN THE UNDERBELLY FUEL TANKS LH/RH HOSE COMPARTMENTS (INTERNAL)	EZAP	2 YR	-	-	NO	YES	147UB ; 148UB	(FROM ABOVE) ACCESS: 223E REMOVAL: CABIN SEATS OR (FROM BELOW) ACCESS: 147B ; 148B
	201151M-01	GVI	GENERAL VISUAL INSPECTION OF EWIS IN THE LEFT AND RIGHT FUEL COMPARTMENT (INTERNAL)	EZAP ; FTS	4 YR	-	-	YES	YES	151 ; 152	ACCESS: 153B ; 154B ; 155A ; 229G ; 229H ; ENG/APU SOV'S & XFEED VALVE COVERS
	201151M-02	GVI	GENERAL VISUAL INSPECTION OF EWIS IN THE LEFT AND RIGHT MAIN FUEL TANK COMPARTMENTS AND LOWER COWLING COMPARTMENTS (INTERNAL)	EZAP ; FTS	4 YR	-	-	NO	YES	151UB ; 152UB ; 157UB ; 158UB ; 159UB	ACCESS: 229G ; 229H ; 229N ; ENG/APU SOV'S & XFEED VALVE COVERS ; 153A ; 153B ; 154A ; 154B ; 155B
	201153M-01	GVI	GENERAL VISUAL INSPECTION OF EWIS IN THE MAIN LANDING GEAR (MLG) COMPARTMENTS	EZAP	4 YR	-	-	YES	YES	153 ; 154	ACCESS: 156A ; 157A

© Copyright 2024 Leonardo S.p.a.

This document contains information that is confidential and proprietary to Leonardo S.p.a. ('the Company') and is supplied on the express condition that it may not be disclosed to any third party, or reproduced in whole or in part, or used for manufacture, or used for any purpose other than for which it is supplied, without the prior written consent of the Company. Every permitted disclosure, reproduction, adaptation or publication of this document in whole or in part and in any manner or form shall prominently contain this notice



AW189 Maintenance Review Board Report

189G0000M006

Issue V

Page 51 of 275

REVISION STATUS	MRB-R TASK NUMBER	TASK CODE	TASK TITLE	SOURCE	INTERVAL	SAMPLING	FEC	APPLICABILITY		ZONE	ACCESS & REMARKS
								AW189	AW189ER		
	201160M-01	GVI	GENERAL VISUAL INSPECTION OF HIGH ENERGY EWIS IN THE LEFT AND RIGHT REAR UPPER AND LOWER FUSELAGE (INTERNAL)	EZAP; L/HIRF	2 YR	-	-	YES	YES	161 ; 162 ; 163 ; 164	ACCESS: 161A ; 165B ; 165G ; 166A ; 168A ; 169A REMOVAL: CEILING LINERS, HEAVY DUTY BAGGAGE COMPARTMENT KIT (if installed)
	201170M-01	RST	RESTORATION (CLEANING ONLY IF CONTAMINATED) OF EWIS IN THE CABIN ROOF AND UPPER FUSELAGE	EZAP	4 YR	-	-	YES	YES	170 ; 180 ; 190	ACCESS: 226A; 226B; 226C; 226D; 226E; 226F; 226G; 226H; 226J; 226K; 227A; 227B; 227C; 227D; 227E; 227F; 227G; 227H; 227J; 227K; 227L; 227M; 227N; 227P; 227Q; 228A; 228B; 228C; 229J; 229K.

© Copyright 2024 Leonardo S.p.a.

This document contains information that is confidential and proprietary to Leonardo S.p.a. ('the Company') and is supplied on the express condition that it may not be disclosed to any third party, or reproduced in whole or in part, or used for manufacture, or used for any purpose other than for which it is supplied, without the prior written consent of the Company. Every permitted disclosure, reproduction, adaptation or publication of this document in whole or in part and in any manner or form shall prominently contain this notice



AW189 Maintenance Review Board Report

189G0000M006

Issue V

Page 52 of 275

REVISION STATUS	MRB-R TASK NUMBER	TASK CODE	TASK TITLE	SOURCE	INTERVAL	SAMPLING	FEC	APPLICABILITY		ZONE	ACCESS & REMARKS
								AW189	AW189ER		
	201170M-02	DI	DETAILED INSPECTION OF EWIS IN THE CABIN ROOF AND UPPER FUSELAGE (INTERNAL)	EZAP	8 YR	-	-	YES	YES	170 ; 180 ; 190	ACCESS: 226A; 226B; 226C; 226D; 226E; 226F; 226G; 226H; 226J; 226K; 227A; 227B; 227C; 227D; 227E; 227F; 227G; 227H; 227J; 227K; 227L; 227M; 227N; 227P; 227Q; 228A; 228B; 228C; 229J; 229K.
	201210M-01	RST	RESTORATION (CLEANING ONLY IF CONTAMINATED) OF EWIS INSTALLED BEHIND THE INSTRUMENT PANEL	EZAP	4 YR	-	-	YES	YES	210	ACCESS: 213 ; 214 REMOVAL: GLARE SHIELD (INCLUDING ECS DIFFUSER COVERS) ; PFD & MFD (IF NECESSARY)
	201210M-02	GVI	GENERAL VISUAL INSPECTION OF EWIS BEHIND THE INSTRUMENT PANEL	EZAP ; L/HIRF	6 YR	-	-	YES	YES	210	ACCESS: 213 ; 214 REMOVAL: GLARE SHIELD (INCLUDING ECS DIFFUSER COVERS)

© Copyright 2024 Leonardo S.p.a.

This document contains information that is confidential and proprietary to Leonardo S.p.a. ('the Company') and is supplied on the express condition that it may not be disclosed to any third party, or reproduced in whole or in part, or used for manufacture, or used for any purpose other than for which it is supplied, without the prior written consent of the Company. Every permitted disclosure, reproduction, adaptation or publication of this document in whole or in part and in any manner or form shall prominently contain this notice



AW189 Maintenance Review Board Report

189G0000M006

Issue V

Page 53 of 275

REVISION STATUS	MRB-R TASK NUMBER	TASK CODE	TASK TITLE	SOURCE	INTERVAL	SAMPLING	FEC	APPLICABILITY		ZONE	ACCESS & REMARKS
								AW189	AW189ER		
	201210M-03	RST	RESTORATION (CLEANING ONLY IF CONTAMINATED) OF EWIS INSTALLED BELOW THE INTERSEAT CONSOLE	EZAP	2 YR	-	-	YES	YES	210	ACCESS: 217A (OR 217B AND 217C) ; INTERSEAT CONSOLE EXTENSION LATERAL ACCESS PANELS (OR APPROPRIATE CONTENTS OF THE EXTENSION) (IF INSTALLED)
	201210M-04	GVI	GENERAL VISUAL INSPECTION OF EWIS BELOW THE INTERSEAT CONSOLE	EZAP	2 YR	-	-	YES	YES	210	ACCESS: 217A (OR 217B AND 217C) ; INTERSEAT CONSOLE EXTENSION LATERAL ACCESS PANELS (OR APPROPRIATE CONTENTS OF THE EXTENSION) (IF INSTALLED)
	201310M-01	RST	RESTORATION (CLEANING ONLY IF CONTAMINATED) OF EWIS IN THE TAIL CONE AND IN THE TAIL PYLON	EZAP	2 YR	-	-	YES	YES	310 ; 320	ACCESS: 311A, 322A, 321A

© Copyright 2024 Leonardo S.p.a.

This document contains information that is confidential and proprietary to Leonardo S.p.a. ('the Company') and is supplied on the express condition that it may not be disclosed to any third party, or reproduced in whole or in part, or used for manufacture, or used for any purpose other than for which it is supplied, without the prior written consent of the Company. Every permitted disclosure, reproduction, adaptation or publication of this document in whole or in part and in any manner or form shall prominently contain this notice



AW189 Maintenance Review Board Report

189G0000M006

Issue V

Page 54 of 275

REVISION STATUS	MRB-R TASK NUMBER	TASK CODE	TASK TITLE	SOURCE	INTERVAL	SAMPLING	FEC	APPLICABILITY		ZONE	ACCESS & REMARKS
								AW189	AW189ER		
	201400M-01	DI	DETAILED INSPECTION OF FULL ICE PROTECTION SYSTEM (FIPS) ELECTRICAL CABLES INSTALLED ON MAIN ROTOR AND TAIL ROTOR ASSEMBLIES	EZAP	1 YR	-	-	WITH FIPS KIT	WITH FIPS KIT	410 ; 430	ACCESS: 451A, 496A
	201450M-01	RST	RESTORATION (CLEANING ONLY IF CONTAMINATED) OF EWIS IN THE FORWARD FAIRING COMPARTMENT	EZAP	1 YR	-	-	YES	YES	450	REMOVAL: 451A
	201450M-02	DI	DETAILED INSPECTION OF EWIS IN THE FORWARD FAIRING COMPARTMENT (INTERNAL)	EZAP ; L/HIRF	2 YR	-	-	YES	YES	450	REMOVAL: 451A
	201460M-01	RST	RESTORATION (CLEANING ONLY IF CONTAMINATED) OF EWIS IN THE ENGINE/APU COMPARTMENTS AND IN THE EXHAUSTS FAIRING COMPARTMENT	EZAP	1 YR	-	-	YES	YES	461 ; 462 ; 463 ; 480	ACCESS: 461A ; 462A ; 463A ; 481A
	201460M-02	GVI	GENERAL VISUAL INSPECTION OF HIGH ENERGY EWIS (115/200 VAC) IN THE ENGINE/APU COMPARTMENTS AND IN THE EXHAUSTS FAIRING COMPARTMENT (INTERNAL)	EZAP	2 YR	-	-	YES	YES	461 ; 462 ; 463 ; 480	ACCESS: 461A ; 462A ; 463A ; 481A

© Copyright 2024 Leonardo S.p.a.

This document contains information that is confidential and proprietary to Leonardo S.p.a. ('the Company') and is supplied on the express condition that it may not be disclosed to any third party, or reproduced in whole or in part, or used for manufacture, or used for any purpose other than for which it is supplied, without the prior written consent of the Company. Every permitted disclosure, reproduction, adaptation or publication of this document in whole or in part and in any manner or form shall prominently contain this notice



AW189 Maintenance Review Board Report

189G0000M006

Issue V

Page 55 of 275

REVISION STATUS	MRB-R TASK NUMBER	TASK CODE	TASK TITLE	SOURCE	INTERVAL	SAMPLING	FEC	APPLICABILITY		ZONE	ACCESS & REMARKS
								AW189	AW189ER		
	201460M-03	SDI	SPECIAL DETAILED INSPECTION (BOROSCOPE INSPECTION) OF HIGH ENERGY EWIS (115/200 VAC) BELOW THE APU COMPARTMENT (INTERNAL)	EZAP ; L/HIRF	1 YR	-	-	YES	YES	464	ACCESS: 481A
	201470M-01	RST	RESTORATION (CLEANING ONLY IF CONTAMINATED) OF EWIS IN THE ENGINE AIR INTAKE COMPARTMENTS, INCLUDING THE ZONE BETWEEN THE ENGINE AIR INTAKES (INTERNAL)	EZAP	1 YR	-	-	YES	YES	470	ACCESS: 451A ; 471A ; 472A
	201470M-02	GVI	GENERAL VISUAL INSPECTION OF EWIS (HIGH ENERGY ONLY) IN THE ENGINE AIR INTAKE COMPARTMENTS, INCLUDING THE ZONE BETWEEN THE ENGINE AIR INTAKES (INTERNAL)	EZAP	2 YR	-	-	YES	YES	470	ACCESS: 451A ; 471A ; 472A
	201490M-01	RST	RESTORATION (CLEANING ONLY IF CONTAMINATED) OF EWIS IN THE DRIVE SHAFT COMPARTMENT	EZAP	1 YR	-	-	YES	YES	490	REMOVAL: UPPER LEADING EDGE FAIRING AND TGB FAIRING ASSY
STAND-ALONE TASKS GENERATED BY L/HIRF											

© Copyright 2024 Leonardo S.p.a.

This document contains information that is confidential and proprietary to Leonardo S.p.a. ('the Company') and is supplied on the express condition that it may not be disclosed to any third party, or reproduced in whole or in part, or used for manufacture, or used for any purpose other than for which it is supplied, without the prior written consent of the Company. Every permitted disclosure, reproduction, adaptation or publication of this document in whole or in part and in any manner or form shall prominently contain this notice



AW189 Maintenance Review Board Report

189G0000M006

Issue V

Page 56 of 275

REVISION STATUS	MRB-R TASK NUMBER	TASK CODE	TASK TITLE	SOURCE	INTERVAL	SAMPLING	FEC	APPLICABILITY		ZONE	ACCESS & REMARKS
								AW189	AW189ER		
	202100M-01	DI	DETAILED INSPECTION OF THE LIGHTNING DIVERTER AND THE DIVERTER ATTACHMENTS ON THE RADOME	L/HIRF	2 YR	-	-	YES	YES	114	ACCESS: EXTERNAL
	202100M-02	GVI	GENERAL VISUAL INSPECTION OF THE LIGHTNING CABLE/CONDUCTOR OF THE HOIST	L/HIRF	1 YR	-	-	WITH SINGLE OR DUAL RESCUE HOIST KIT	WITH SINGLE OR DUAL RESCUE HOIST KIT	180	REMOVAL: SINGLE/DUAL HOIST COVER
	202100M-03	GVI	GENERAL VISUAL INSPECTION OF THE ICE DETECTOR BONDING PLATE (VISIBLE PART)	L/HIRF	1 YR	-	-	WITH LIPS/FIPS KIT	WITH LIPS/FIPS KIT	100	REMOVAL: ICE DETECTOR HEAD ACCESS COVER
	202100M-04	DI	DETAILED INSPECTION OF THE ICE DETECTOR CONNECTORS	L/HIRF	1 YR	-	-	WITH LIPS/FIPS KIT	WITH LIPS/FIPS KIT	100	REMOVAL: ICE DETECTOR HEAD ACCESS COVER
	202100M-05	FC	FUNCTIONAL CHECK (CONTINUITY CHECK) OF THE LIGHTNING DIVERTER ON THE GLIDESLOPE FAIRING.	L/HIRF	2 YR	-	-	NO	WITH EXTERNAL GLIDESLOPE ANTENNA KIT	100	ACCESS: EXTERNAL
	202149M-01	DI	DETAILED INSPECTION OF THE CARGO HOOK ASSEMBLY BONDING STRAP	L/HIRF	1 YR	-	-	WITH CARGO HOOK KIT	WITH CARGO HOOK KIT	149	ACCESS: 149C

© Copyright 2024 Leonardo S.p.a.

This document contains information that is confidential and proprietary to Leonardo S.p.a. ('the Company') and is supplied on the express condition that it may not be disclosed to any third party, or reproduced in whole or in part, or used for manufacture, or used for any purpose other than for which it is supplied, without the prior written consent of the Company. Every permitted disclosure, reproduction, adaptation or publication of this document in whole or in part and in any manner or form shall prominently contain this notice



AW189 Maintenance Review Board Report

189G0000M006

Issue V

Page 57 of 275

REVISION STATUS	MRB-R TASK NUMBER	TASK CODE	TASK TITLE	SOURCE	INTERVAL	SAMPLING	FEC	APPLICABILITY		ZONE	ACCESS & REMARKS
								AW189	AW189ER		
	202149M-02	DI	DETAILED INSPECTION OF THE CARGO HOOK CONNECTORS	L/HIRF	1 YR	-	-	WITH CARGO HOOK KIT	WITH CARGO HOOK KIT	100, 200, 300 & 400 (external)	ACCESS: EXTERNAL
	202310M-01	GVI	GENERAL VISUAL INSPECTION OF THE BONDING STRAP BETWEEN THE UPPER TRAILING EDGE OF THE TAIL PYLON AND THE TAIL GEAR BOX (TGB) FAIRING	L/HIRF	2 YR	-	-	YES	YES	320	ACCESS: 322A
	202400M-01	GVI	GENERAL VISUAL INSPECTION OF THE BONDING STRAPS INSTALLED ON THE MAIN ROTOR AND TAIL ROTOR ASSEMBLIES	L/HIRF	1 YR	-	-	YES	YES	400	ACCESS: 451A

© Copyright 2024 Leonardo S.p.a.

This document contains information that is confidential and proprietary to Leonardo S.p.a. ('the Company') and is supplied on the express condition that it may not be disclosed to any third party, or reproduced in whole or in part, or used for manufacture, or used for any purpose other than for which it is supplied, without the prior written consent of the Company. Every permitted disclosure, reproduction, adaptation or publication of this document in whole or in part and in any manner or form shall prominently contain this notice



AW189 Maintenance Review Board Report

189G0000M006

Issue V

Page 58 of 275

REVISION STATUS	MRB-R TASK NUMBER	TASK CODE	TASK TITLE	SOURCE	INTERVAL	SAMPLING	FEC	APPLICABILITY		ZONE	ACCESS & REMARKS
								AW189	AW189ER		
	202400M-02	DI	DETAILED INSPECTION OF THE BONDING STRIPS ON THE MAIN ROTOR BLADES INCLUDING THE SEGMENT IN CONTACT WITH THE METALLIC PLATE FIXED ON THE MAIN ROTOR HUB INTERVAL NOTE: SHOULD BE ACCOMPLISHED IN CONJUNCTION WITH 202400M-03	L/HIRF	1 YR	-	-	YES	YES	400	ACCESS: 451A
	202400M-03	DI	DETAILED INSPECTION OF THE METALLIC PLATES INSTALLED IN THE MAIN ROTOR AND TAIL ROTOR ASSEMBLIES INTERVAL NOTE: SHOULD BE ACCOMPLISHED IN CONJUNCTION WITH 202400M-02	L/HIRF	1 YR	-	-	YES	YES	400	ACCESS: 451A

© Copyright 2024 Leonardo S.p.a.

This document contains information that is confidential and proprietary to Leonardo S.p.a. ('the Company') and is supplied on the express condition that it may not be disclosed to any third party, or reproduced in whole or in part, or used for manufacture, or used for any purpose other than for which it is supplied, without the prior written consent of the Company. Every permitted disclosure, reproduction, adaptation or publication of this document in whole or in part and in any manner or form shall prominently contain this notice



AW189 Maintenance Review Board Report

189G0000M006

Issue V

Page 59 of 275

REVISION STATUS	MRB-R TASK NUMBER	TASK CODE	TASK TITLE	SOURCE	INTERVAL	SAMPLING	FEC	APPLICABILITY		ZONE	ACCESS & REMARKS
								AW189	AW189ER		
	202490M-01	GVI	GENERAL VISUAL INSPECTION OF THE BONDING STRAP IN THE TAIL ROTOR DRIVE SHAFT COMPARTMENT	L/HIRF	1 YR	-	-	YES	YES	490	ACCESS: EXHAUST SLIDING FAIRING COMPARTMENT
ATA 21: AIR CONDITIONING											
MSI 21-20-00: VENTILATION											
	212000M-01	GVI	GENERAL VISUAL INSPECTION OF CABINET COOLING DUCT NOTE: APPLICABLE ONLY TO P/N 8G2120A08811 AND 8G2120F00411 CREDIT FOR ACCOMPLISHMENT CAN BE TAKEN FROM <u>300200M-07</u>	MSI	4 YR	-	9	WITH AVIONIC COOLING EQUIPMENT INSTALLATION	WITH AVIONIC COOLING EQUIPMENT INSTALLATION	-	-
MSI 21-40-00: HEATING											
	214000M-01	OC	OPERATIONAL CHECK OF ENGINE 1 SHUT OFF VALVE	MSI	1600 FH ; 2 YR	-	8	WITH CT7-2E1 ENGINE INSTALLATION	WITH CT7-2E1 ENGINE INSTALLATION	-	-
	214000M-02	OC	OPERATIONAL CHECK OF ENGINE 2 SHUT OFF VALVE	MSI	1600 FH ; 2 YR	-	8	WITH CT7-2E1 ENGINE INSTALLATION	WITH CT7-2E1 ENGINE INSTALLATION	-	-

© Copyright 2024 Leonardo S.p.a.

This document contains information that is confidential and proprietary to Leonardo S.p.a. ('the Company') and is supplied on the express condition that it may not be disclosed to any third party, or reproduced in whole or in part, or used for manufacture, or used for any purpose other than for which it is supplied, without the prior written consent of the Company. Every permitted disclosure, reproduction, adaptation or publication of this document in whole or in part and in any manner or form shall prominently contain this notice



AW189 Maintenance Review Board Report

189G0000M006

Issue V

Page 60 of 275

REVISION STATUS	MRB-R TASK NUMBER	TASK CODE	TASK TITLE	SOURCE	INTERVAL	SAMPLING	FEC	APPLICABILITY		ZONE	ACCESS & REMARKS
								AW189	AW189ER		
	214000M-03	OC	OPERATIONAL CHECK OF APU SHUT OFF VALVE	MSI	1600 FH ; 2 YR	-	8	YES	YES	-	-
	214000M-04	FC	FUNCTIONAL CHECK OF THE DUCT OVER TEMPERATURE SWITCH (DOTS) SETTING OFF AIRCRAFT	MSI	1600 FH ; 2 YR	-	6 ; 8	YES	YES	-	-
MSI 21-50-00: COOLING KIT											
	215000M-01		TASK DELETED WITH MRBR ISSUE L								
ATA 22: AUTO FLIGHT											
MSI 22-10-00: AUTOPILOT											

© Copyright 2024 Leonardo S.p.a.

This document contains information that is confidential and proprietary to Leonardo S.p.a. ('the Company') and is supplied on the express condition that it may not be disclosed to any third party, or reproduced in whole or in part, or used for manufacture, or used for any purpose other than for which it is supplied, without the prior written consent of the Company. Every permitted disclosure, reproduction, adaptation or publication of this document in whole or in part and in any manner or form shall prominently contain this notice



AW189 Maintenance Review Board Report

189G0000M006

Issue V

Page 61 of 275

REVISION STATUS	MRB-R TASK NUMBER	TASK CODE	TASK TITLE	SOURCE	INTERVAL	SAMPLING	FEC	APPLICABILITY		ZONE	ACCESS & REMARKS
								AW189	AW189ER		
	221000M-01	RST	RESTORATION (OVERHAUL) OF TAIL ROTOR SERVO-ACTUATOR OFF AIRCRAFT NOTE: IDENTICAL TO 673000M-06	MSI	5000 FH	-	6	YES	YES	-	-
	221000M-02	GVI	GENERAL VISUAL INSPECTION OF TAIL ROTOR SERVO-ACTUATOR NOTE: IDENTICAL TO 673000M-05	MSI	400 FH	-	6	YES	YES	-	-
ATA 23: COMMUNICATIONS											
MSI 23-15-00: SATCOM SKYTRACK											
	231500M-01	DI	DETAILED INSPECTION OF SATCOM SKYTRAC BATTERY PACK	MSI	1 YR	-	9	WITH SATCOM SKYTRAC KIT	WITH SATCOM SKYTRAC KIT	-	-
	231500M-02	-	TASK DELETED WITH MRBR ISSUE H	-	-	-	-	-	-	-	-
MSI 23-30-00: VISUAL / AUDIO PAX ADDRESS SYSTEM KIT											

© Copyright 2024 Leonardo S.p.a.

This document contains information that is confidential and proprietary to Leonardo S.p.a. ('the Company') and is supplied on the express condition that it may not be disclosed to any third party, or reproduced in whole or in part, or used for manufacture, or used for any purpose other than for which it is supplied, without the prior written consent of the Company. Every permitted disclosure, reproduction, adaptation or publication of this document in whole or in part and in any manner or form shall prominently contain this notice



AW189 Maintenance Review Board Report

189G0000M006

Issue V

Page 62 of 275

REVISION STATUS	MRB-R TASK NUMBER	TASK CODE	TASK TITLE	SOURCE	INTERVAL	SAMPLING	FEC	APPLICABILITY		ZONE	ACCESS & REMARKS
								AW189	AW189ER		
	233000M-01	DI	DETAILED INSPECTION OF THE PASSENGER ADDRESS MONITOR ATTACHMENTS	MSI	3200 FH	-	8	WITH VISUAL / AUDIO PAX ADDRESS SYSTEM KIT	WITH VISUAL / AUDIO PAX ADDRESS SYSTEM KIT	-	-
MSI 23-50-00: AUDIO INTEGRATING AND VOICE COMMAND SYSTEMS											
	235000M-01	OC	OPERATIONAL CHECK OF ICS MANUAL EMERGENCY MODE	MSI	2 YR	-	9	WITHOUT ICS SAR KIT	WITHOUT ICS SAR KIT	-	-
MSI 23-52-00: SAR ICS KIT											
	235200M-01	OC	OPERATIONAL CHECK OF ICS MANUAL EMERGENCY MODE	MSI	2 YR	-	9	WITH ICS SAR KIT	WITH ICS SAR KIT	-	-
ATA 24: ELECTRIC POWER											
MSI 24-20-00: AC GENERATION											
	242000M-01	RST	RESTORATION (OVERHAUL) OF STARTER GENERATOR OFF AIRCRAFT	MSI	2400 FH	-	6	YES	YES	-	-
	242000M-02	RST	RESTORATION (OVERHAUL) OF APU GENERATOR OFF AIRCRAFT	MSI	3000 APU_H	-	9	YES	YES	-	-

© Copyright 2024 Leonardo S.p.a.

This document contains information that is confidential and proprietary to Leonardo S.p.a. ('the Company') and is supplied on the express condition that it may not be disclosed to any third party, or reproduced in whole or in part, or used for manufacture, or used for any purpose other than for which it is supplied, without the prior written consent of the Company. Every permitted disclosure, reproduction, adaptation or publication of this document in whole or in part and in any manner or form shall prominently contain this notice



AW189 Maintenance Review Board Report

189G0000M006

Issue V

Page 63 of 275

REVISION STATUS	MRB-R TASK NUMBER	TASK CODE	TASK TITLE	SOURCE	INTERVAL	SAMPLING	FEC	APPLICABILITY		ZONE	ACCESS & REMARKS
								AW189	AW189ER		
	242000M-03	-	TASK DELETED WITH MRBR ISSUE G	-	-	-	-	-	-	-	-
	242000M-04	GVI	GENERAL VISUAL INSPECTION OF APU GENERATOR QUICK ATTACHMENT DEVICE (QAD)	MSI	400 FH	-	9	YES	YES	-	-
	242000M-05	GVI	GENERAL VISUAL INSPECTION OF ENGINE STARTER GENERATOR QUICK ATTACHMENT DEVICE (QAD)	MSI	400 FH	-	6	YES	YES	-	-
	242000M-06	OC	OPERATIONAL CHECK OF THE GROUND FAULT INTERRUPTER	MSI	6 MH	-	8 ; 9	WITH AC UTILITY SOCKET KIT	WITH AC UTILITY SOCKET KIT	-	-

© Copyright 2024 Leonardo S.p.a.

This document contains information that is confidential and proprietary to Leonardo S.p.a. ('the Company') and is supplied on the express condition that it may not be disclosed to any third party, or reproduced in whole or in part, or used for manufacture, or used for any purpose other than for which it is supplied, without the prior written consent of the Company. Every permitted disclosure, reproduction, adaptation or publication of this document in whole or in part and in any manner or form shall prominently contain this notice



AW189 Maintenance Review Board Report

189G0000M006

Issue V

Page 64 of 275

REVISION STATUS	MRB-R TASK NUMBER	TASK CODE	TASK TITLE	SOURCE	INTERVAL	SAMPLING	FEC	APPLICABILITY		ZONE	ACCESS & REMARKS
								AW189	AW189ER		
	242000M-07	FC	FUNCTIONAL CHECK (DIMENSIONAL CHECK) OF THE STARTER GENERATOR DRIVE SHAFT INTERVAL NOTE: SG P/N 8G2420V00551 MOD std=<9 (PRE SB189-235) - 400 FH SG P/N 8G2420V00551 MOD std=>10 (POST SB189-235) / SG P/N 8G2420V00451 / SG P/N 8G2420V00651 - 1200 FH	MSI	NOTE	-	6	YES	YES	-	-
MSI 24-30-00: DC GENERATION											
	243000M-01	RST	RESTORATION (DEEP CYCLE) OF MAIN BATTERY OFF AIRCRAFT	MSI	1 YR	-	9	YES	YES	-	-
	243000M-02	OC	OPERATIONAL CHECK OF DC SYSTEM AUTOMATIC RECONFIGURATION AS PER POWER SOURCE LOGIC	MSI	2400 FH	-	9	YES	YES	-	-

© Copyright 2024 Leonardo S.p.a.

This document contains information that is confidential and proprietary to Leonardo S.p.a. ('the Company') and is supplied on the express condition that it may not be disclosed to any third party, or reproduced in whole or in part, or used for manufacture, or used for any purpose other than for which it is supplied, without the prior written consent of the Company. Every permitted disclosure, reproduction, adaptation or publication of this document in whole or in part and in any manner or form shall prominently contain this notice



AW189 Maintenance Review Board Report

189G0000M006

Issue V

Page 65 of 275

REVISION STATUS	MRB-R TASK NUMBER	TASK CODE	TASK TITLE	SOURCE	INTERVAL	SAMPLING	FEC	APPLICABILITY		ZONE	ACCESS & REMARKS
								AW189	AW189ER		
	243000M-03	FC	FUNCTIONAL CHECK (VOLTAGE AND FAIL INDICATION CHECK) OF EMERGENCY BUS VOLTAGE AND FAIL INDICATION	MSI	2400 FH	-	9	YES	YES	-	-
	243000M-04	-	TASK DELETED WITH MRBR ISSUE G	-	-	-	-	-	-	-	-
	243000M-05	FC	FUNCTIONAL CHECK (RESISTANCE MEASUREMENT) OF MAIN BATTERY TEMPERATURE SENSOR OFF AIRCRAFT NOTE: SHOULD BE ACCOMPLISHED IN CONJUNCTION WITH 243000M-01	MSI	1 YR	-	9	YES	YES	-	-
ATA 25: EQUIPMENT / FURNISHINGS											
MSI 25-10-00: FLIGHT COMPARTMENT											

© Copyright 2024 Leonardo S.p.a.

This document contains information that is confidential and proprietary to Leonardo S.p.a. ('the Company') and is supplied on the express condition that it may not be disclosed to any third party, or reproduced in whole or in part, or used for manufacture, or used for any purpose other than for which it is supplied, without the prior written consent of the Company. Every permitted disclosure, reproduction, adaptation or publication of this document in whole or in part and in any manner or form shall prominently contain this notice



AW189 Maintenance Review Board Report

189G0000M006

Issue V

Page 66 of 275

REVISION STATUS	MRB-R TASK NUMBER	TASK CODE	TASK TITLE	SOURCE	INTERVAL	SAMPLING	FEC	APPLICABILITY		ZONE	ACCESS & REMARKS
								AW189	AW189ER		
	251000M-01	DI	DETAILED INSPECTION OF PILOT/CO-PILOT SEAT STRUCTURE AND ATTACHMENT POINTS TO TRACKS, INCLUDING TRACKS AND LOCKING PINS	MSI	2 YR	-	6; 8	YES	YES	-	-
	251000M-02	DI	DETAILED INSPECTION OF PILOT/ CO-PILOT SEAT BELT	MSI	1 YR	-	8	YES	YES	-	-
	251000M-03	OC	OPERATIONAL CHECK OF THE SEAT BELT LOCKING AND INERTIAL MECHANISM	MSI	1 YR	-	8	YES	YES	-	-
	251000M-04	-	TASK DELETED WITH MRBR ISSUE B	-	-	-	-	-	-	-	-
MSI 25-21-00: PASSENGER/OPERATING CREW											
	252100M-01	DI	DETAILED INSPECTION OF CABIN SEAT STRUCTURE AND ATTACHMENT POINTS, INCLUDING TRACKS	MSI	2 YR	-	8; 9	YES	YES	-	-
	252100M-02	DI	DETAILED INSPECTION OF CABIN SEAT BELT	MSI	1 YR	-	8	YES	YES	-	-
	252100M-03	OC	OPERATIONAL CHECK OF CABIN SEAT BELT LOCKING AND INERTIAL MECHANISM	MSI	1 YR	-	8	YES	YES	-	-
	252100M-04	-	TASK DELETED WITH MRBR ISSUE B	-	-	-	-	-	-	-	-

© Copyright 2024 Leonardo S.p.a.

This document contains information that is confidential and proprietary to Leonardo S.p.a. ('the Company') and is supplied on the express condition that it may not be disclosed to any third party, or reproduced in whole or in part, or used for manufacture, or used for any purpose other than for which it is supplied, without the prior written consent of the Company. Every permitted disclosure, reproduction, adaptation or publication of this document in whole or in part and in any manner or form shall prominently contain this notice



AW189 Maintenance Review Board Report

189G0000M006

Issue V

Page 67 of 275

REVISION STATUS	MRB-R TASK NUMBER	TASK CODE	TASK TITLE	SOURCE	INTERVAL	SAMPLING	FEC	APPLICABILITY		ZONE	ACCESS & REMARKS
								AW189	AW189ER		
	252100M-05	DI	DETAILED INSPECTION OF FOURTH ROW SEAT STRUCTURE AND ATTACHMENT POINTS, INCLUDING FITTINGS	MSI	2 YR	-	8; 9	YES	YES	-	-
	252100M-06	DI	DETAILED INSPECTION OF TROOP SEAT ASSEMBLY	MSI	2 YR	-	8	WITH FOLDING TROOP SEATS	WITH FOLDING TROOP SEATS	-	-
	252100M-07	DI	DETAILED INSPECTION OF TROOP SEAT FLOOR / CEILING SEAT TRACK	MSI	2 YR	-	8	WITH FOLDING TROOP SEATS	WITH FOLDING TROOP SEATS	-	-
	252100M-08	DI	DETAILED INSPECTION OF 4TH ROW (REAR ROW) CENTRE CABIN SEAT FOLDING INSTALLATION	MSI	1 YR	-	8; 9	WITH 4TH ROW FOLDING CABIN SEATS	WITH 4TH ROW FOLDING CABIN SEATS	-	-
	252100M-09	FC	FUNCTIONAL CHECK (GAP MEASUREMENT) OF TROOP SEAT ENERGY ABSORBING DEVICE	MSI	1 YR	-	8	WITH FOLDING TROOP SEATS	WITH FOLDING TROOP SEATS	-	-
	252100M-10	DIS	DISCARD TROOP SEAT RESTRAINT SYSTEM INTERVAL NOTE: 12 YR FROM MANUFACTURING	MSI	NOTE	-	8	WITH FOLDING TROOP SEATS	WITH FOLDING TROOP SEATS	-	-
MSI 25-24-00: SAR CABIN INTERIOR KIT											

© Copyright 2024 Leonardo S.p.a.

This document contains information that is confidential and proprietary to Leonardo S.p.a. ('the Company') and is supplied on the express condition that it may not be disclosed to any third party, or reproduced in whole or in part, or used for manufacture, or used for any purpose other than for which it is supplied, without the prior written consent of the Company. Every permitted disclosure, reproduction, adaptation or publication of this document in whole or in part and in any manner or form shall prominently contain this notice



AW189 Maintenance Review Board Report

189G0000M006

Issue V

Page 68 of 275

REVISION STATUS	MRB-R TASK NUMBER	TASK CODE	TASK TITLE	SOURCE	INTERVAL	SAMPLING	FEC	APPLICABILITY		ZONE	ACCESS & REMARKS
								AW189	AW189ER		
	252400M-01	-	TASK DELETED WITH MRBR ISSUE P	-	-	-	-	-	-	-	-
	252400M-02	-	TASK DELETED WITH MRBR ISSUE P	-	-	-	-	-	-	-	-
	252400M-03	-	TASK DELETED WITH MRBR ISSUE P	-	-	-	-	-	-	-	-
	252400M-04	-	TASK DELETED WITH MRBR ISSUE P	-	-	-	-	-	-	-	-
	252400M-05	-	TASK DELETED WITH MRBR ISSUE P	-	-	-	-	-	-	-	-
	252400M-06	-	TASK DELETED WITH MRBR ISSUE P	-	-	-	-	-	-	-	-

© Copyright 2024 Leonardo S.p.a.

This document contains information that is confidential and proprietary to Leonardo S.p.a. ('the Company') and is supplied on the express condition that it may not be disclosed to any third party, or reproduced in whole or in part, or used for manufacture, or used for any purpose other than for which it is supplied, without the prior written consent of the Company. Every permitted disclosure, reproduction, adaptation or publication of this document in whole or in part and in any manner or form shall prominently contain this notice



AW189 Maintenance Review Board Report

189G0000M006

Issue V

Page 69 of 275

REVISION STATUS	MRB-R TASK NUMBER	TASK CODE	TASK TITLE	SOURCE	INTERVAL	SAMPLING	FEC	APPLICABILITY		ZONE	ACCESS & REMARKS
								AW189	AW189ER		
	252400M-07	-	TASK DELETED WITH MRBR ISSUE P	-	-	-	-	-	-	-	-
	252400M-08	-	TASK DELETED WITH MRBR ISSUE P	-	-	-	-	-	-	-	-
MSI 25-25-00: CEILING ROPE KIT (TASKS TRANSFERRED TO ZONAL)											
MSI 25-50-00: CARGO RESTRAINT SYSTEMS											
	255000M-01	DI	DETAILED INSPECTION OF THE CARGO NET	MSI	800FH ; 1 YR	-	8 ; 9	WITH CARGO RESTRAINT SYSTEM KIT OR TUNNEL NET KIT OR HEAVY DUTY BAGGAGE COMPARTMENT KITS	WITH CARGO RESTRAINT SYSTEM KIT OR TUNNEL NET KIT OR HEAVY DUTY BAGGAGE COMPARTMENT KITS	-	-

© Copyright 2024 Leonardo S.p.a.

This document contains information that is confidential and proprietary to Leonardo S.p.a. ('the Company') and is supplied on the express condition that it may not be disclosed to any third party, or reproduced in whole or in part, or used for manufacture, or used for any purpose other than for which it is supplied, without the prior written consent of the Company. Every permitted disclosure, reproduction, adaptation or publication of this document in whole or in part and in any manner or form shall prominently contain this notice



AW189 Maintenance Review Board Report

189G0000M006

Issue V

Page 70 of 275

REVISION STATUS	MRB-R TASK NUMBER	TASK CODE	TASK TITLE	SOURCE	INTERVAL	SAMPLING	FEC	APPLICABILITY		ZONE	ACCESS & REMARKS
								AW189	AW189ER		
	255000M-02	DI	DETAILED INSPECTION OF STOWAGE PROVISION FLOOR ANCHOR POINTS AND WALL RAILS	MSI	2 YR	-	8	WITH ADDITIONAL TUNNEL STOWAGE ZONE KIT	WITH ADDITIONAL TUNNEL STOWAGE ZONE KIT	-	-
	255000M-03	DI	DETAILED INSPECTION OF BAGGAGE COMPARTMENT BOXES IN CABIN AND FITTINGS	MSI	2 YR	-	8	WITH BAGGAGE COMPARTMENT BOXES IN CABIN KIT	WITH BAGGAGE COMPARTMENT BOXES IN CABIN KIT	-	-
	255000M-04	GVI	GENERAL VISUAL INSPECTION OF HEAVY DUTY BAGGAGE COMPARTMENT BARRIER PANELS NOTE: COVERS <u>258000M-01</u>	MSI	400FH ; 1 YR NOTE_B	-	9	WITH HEAVY DUTY BAGGAGE COMPARTMENT KIT	WITH HEAVY DUTY BAGGAGE COMPARTMENT KIT	-	-
MSI 25-61-00: ELT KIT											
	256100M-01	OC	OPERATIONAL CHECK OF EMERGENCY LOCATOR TRANSMITTER (ELT) INCLUDING G-SWITCH	MSI	1 YR	-	8	WITH ELT KIT	WITH ELT KIT	-	-

© Copyright 2024 Leonardo S.p.a.

This document contains information that is confidential and proprietary to Leonardo S.p.a. ('the Company') and is supplied on the express condition that it may not be disclosed to any third party, or reproduced in whole or in part, or used for manufacture, or used for any purpose other than for which it is supplied, without the prior written consent of the Company. Every permitted disclosure, reproduction, adaptation or publication of this document in whole or in part and in any manner or form shall prominently contain this notice



AW189 Maintenance Review Board Report

189G0000M006

Issue V

Page 71 of 275

REVISION STATUS	MRB-R TASK NUMBER	TASK CODE	TASK TITLE	SOURCE	INTERVAL	SAMPLING	FEC	APPLICABILITY		ZONE	ACCESS & REMARKS
								AW189	AW189ER		
	256100M-02	DIS	DISCARD EMERGENCY LOCATOR TRANSMITTER (ELT) BATTERY INTERVAL NOTE: EXPIRY DATE REPORTED IN THE ELT TAG	MSI	NOTE	-	8	WITH ELT KIT	WITH ELT KIT	-	-
MSI 25-62-00: ADELT KIT											
	256200M-01	OC	OPERATIONAL CHECK OF AUTOMATIC DEPLOYABLE EMERGENCY LOCATOR TRANSMITTER (ADELT)	MSI	1 YR	-	8	WITH ADELT KIT	WITH ADELT KIT	-	-
	256200M-02	DI	DETAILED INSPECTION OF SYSTEM INTERFACE UNIT (SIU) AND THE GASKET SEAL NOTE: SHOULD BE ACCOMPLISHED IN CONJUNCTION WITH <u>256200M-04</u>	MSI	1YR	-	8	WITH ADELT KIT	WITH ADELT KIT	-	-
	256200M-03	RST	RESTORATION (OVERHAUL) OF SYSTEM INTERFACE UNIT (SIU) OFF AIRCRAFT	MSI	10 YR	-	8	WITH ADELT KIT	WITH ADELT KIT	-	-

© Copyright 2024 Leonardo S.p.a.

This document contains information that is confidential and proprietary to Leonardo S.p.a. ('the Company') and is supplied on the express condition that it may not be disclosed to any third party, or reproduced in whole or in part, or used for manufacture, or used for any purpose other than for which it is supplied, without the prior written consent of the Company. Every permitted disclosure, reproduction, adaptation or publication of this document in whole or in part and in any manner or form shall prominently contain this notice



AW189 Maintenance Review Board Report

189G0000M006

Issue V

Page 72 of 275

REVISION STATUS	MRB-R TASK NUMBER	TASK CODE	TASK TITLE	SOURCE	INTERVAL	SAMPLING	FEC	APPLICABILITY		ZONE	ACCESS & REMARKS
								AW189	AW189ER		
	256200M-04	DIS	DISCARD SYSTEM INTERFACE UNIT (SIU) BATTERY INTERVAL NOTE: 1 YR OR WITHIN BATTERY EXPIRY DATE NOTE: SHOULD BE ACCOMPLISHED IN CONJUNCTION WITH <u>256200M-02</u>	MSI	NOTE	-	8	WITH ADELT KIT	WITH ADELT KIT	-	-
	256200M-05	DI	DETAILED INSPECTION OF CPI BEACON & BEACON RELEASE UNIT OFF AIRCRAFT	MSI	1 YR	-	8	WITH ADELT KIT	WITH ADELT KIT	-	-
	256200M-06	RST	RESTORATION (OVERHAUL) OF BEACON RELEASE UNIT INTERVAL NOTE: 10 YR FROM MANUFACTURING DATE (SEE EXPIRY DATE ON BRU TAG) OFF AIRCRAFT	MSI	NOTE	-	8	WITH ADELT KIT	WITH ADELT KIT	-	-

© Copyright 2024 Leonardo S.p.a.

This document contains information that is confidential and proprietary to Leonardo S.p.a. ('the Company') and is supplied on the express condition that it may not be disclosed to any third party, or reproduced in whole or in part, or used for manufacture, or used for any purpose other than for which it is supplied, without the prior written consent of the Company. Every permitted disclosure, reproduction, adaptation or publication of this document in whole or in part and in any manner or form shall prominently contain this notice



AW189 Maintenance Review Board Report

189G0000M006

Issue V

Page 73 of 275

REVISION STATUS	MRB-R TASK NUMBER	TASK CODE	TASK TITLE	SOURCE	INTERVAL	SAMPLING	FEC	APPLICABILITY		ZONE	ACCESS & REMARKS
								AW189	AW189ER		
	256200M-07	DIS	DISCARD CPI BEACON BATTERY OFF AIRCRAFT INTERVAL NOTE: EXPIRY DATE REPORTED IN THE BEACON TAG	MSI	NOTE	-	8	WITH ADELT KIT	WITH ADELT KIT	-	-
	256200M-08	-	TASK DELETED WITH MRBR ISSUE C	-	-	-	-	-	-	-	-
	256200M-09	OC	OPERATIONAL CHECK OF AUTOMATIC DEPLOYABLE EMERGENCY LOCATOR TRANSMITTER (ADELT) WATER ACTIVATED SWITCH	MSI	3 YR	-	8	WITH ADELT KIT	WITH ADELT KIT	-	-
	256200M-10	DI	DETAILED INSPECTION OF AUTOMATIC DEPLOYABLE EMERGENCY LOCATOR TRANSMITTER (ADELT) WATER ACTIVATED SWITCH	MSI	1 YR	-	8	WITH ADELT KIT	WITH ADELT KIT	-	-

© Copyright 2024 Leonardo S.p.a.

This document contains information that is confidential and proprietary to Leonardo S.p.a. ('the Company') and is supplied on the express condition that it may not be disclosed to any third party, or reproduced in whole or in part, or used for manufacture, or used for any purpose other than for which it is supplied, without the prior written consent of the Company. Every permitted disclosure, reproduction, adaptation or publication of this document in whole or in part and in any manner or form shall prominently contain this notice



AW189 Maintenance Review Board Report

189G0000M006

Issue V

Page 74 of 275

REVISION STATUS	MRB-R TASK NUMBER	TASK CODE	TASK TITLE	SOURCE	INTERVAL	SAMPLING	FEC	APPLICABILITY		ZONE	ACCESS & REMARKS
								AW189	AW189ER		
	256200M-11	FC	FUNCTIONAL CHECK (CONTINUITY CHECK) OF AUTOMATIC DEPLOYABLE EMERGENCY LOCATOR TRANSMITTER (ADELT) COCKPIT CONTROL PANEL SWITCHES	MSI	3 YR	-	8	WITH ADELT KIT	WITH ADELT KIT	-	-
MSI 25-63-00: FIRST AID KIT											
	256300M-01	DI	DETAILED INSPECTION OF FIRST AID KIT	MSI	1 YR	-	8	WITH FIRST AID KIT (LH)	WITH FIRST AID KIT (LH)	-	-
MSI 25-65-00: UNDERWATER LOCATOR BEACON KIT											
	256500M-01	FC	FUNCTIONAL CHECK (VOLTAGE AND SIGNAL OUTPUT) OF UNDERWATER LOCATOR BEACON (ULB)	MSI	6 MH	-	9	WITH UNDERWATER LOCATOR BEACON KIT	WITH UNDERWATER LOCATOR BEACON KIT	-	-
	256500M-02	DIS	DISCARD UNDERWATER LOCATOR BEACON (ULB) BATTERY INTERVAL NOTE : EXPIRY DATE REPORTED ON THE ULB TAG	MSI	NOTE	-	9	WITH UNDERWATER LOCATOR BEACON KIT	WITH UNDERWATER LOCATOR BEACON KIT	-	-
MSI 25-80-00: INSULATION AND LINING											

© Copyright 2024 Leonardo S.p.a.

This document contains information that is confidential and proprietary to Leonardo S.p.a. ('the Company') and is supplied on the express condition that it may not be disclosed to any third party, or reproduced in whole or in part, or used for manufacture, or used for any purpose other than for which it is supplied, without the prior written consent of the Company. Every permitted disclosure, reproduction, adaptation or publication of this document in whole or in part and in any manner or form shall prominently contain this notice



AW189 Maintenance Review Board Report

189G0000M006

Issue V

Page 75 of 275

REVISION STATUS	MRB-R TASK NUMBER	TASK CODE	TASK TITLE	SOURCE	INTERVAL	SAMPLING	FEC	APPLICABILITY		ZONE	ACCESS & REMARKS
								AW189	AW189ER		
	258000M-01	GVI	GENERAL VISUAL INSPECTION OF BAGGAGE COMPARTMENT LINERS NOTE: CREDIT FOR ACCOMPLISHMENT CAN BE TAKEN FROM 255000M-04	MSI	400 FH ; 1 YR	-	8 ; 9	YES	YES	-	-
	258000M-02	DI	DETAILED INSPECTION OF BAGGAGE COMPARTMENT LINER SEALS	MSI	3200 FH ; 4 YR	-	8	YES	YES	-	-
MSI 25-84-00: SEA TRAY											
	258400M-01	DI	DETAILED INSPECTION OF SEA TRAY AND CABIN FLOOR	MSI	1 YR ; NOTE_B	-	9	WITH SEA TRAY KITS	WITH SEA TRAY KITS	-	-
	258400M-02	DI	DETAILED INSPECTION OF FLEXIBLE SEA TRAY AND ROW SEAT PROTECTORS	MSI	1 MH ; NOTE_B	-	9	WITH FLEXIBLE SEA TRAY KIT	WITH FLEXIBLE SEA TRAY KIT	-	-
MSI 25-91-00: SINGLE RESCUE HOIST											
	259100M-01	GVI	GENERAL VISUAL INSPECTION OF HOIST OIL LEVEL INTERVAL NOTE: 1 MH OR 3 HOURS OF HOIST OPERATION	MSI	NOTE	-	6	WITH SINGLE RESCUE HOIST KIT	WITH SINGLE RESCUE HOIST KIT	-	-

© Copyright 2024 Leonardo S.p.a.

This document contains information that is confidential and proprietary to Leonardo S.p.a. ('the Company') and is supplied on the express condition that it may not be disclosed to any third party, or reproduced in whole or in part, or used for manufacture, or used for any purpose other than for which it is supplied, without the prior written consent of the Company. Every permitted disclosure, reproduction, adaptation or publication of this document in whole or in part and in any manner or form shall prominently contain this notice



AW189 Maintenance Review Board Report

189G0000M006

Issue V

Page 76 of 275

REVISION STATUS	MRB-R TASK NUMBER	TASK CODE	TASK TITLE	SOURCE	INTERVAL	SAMPLING	FEC	APPLICABILITY		ZONE	ACCESS & REMARKS
								AW189	AW189ER		
	259100M-02	SV	SERVICING (OIL REPLACEMENT) OF HOIST ASSEMBLY	MSI	6 MH ; 400 HOIST LIFTS	-	6	WITH SINGLE RESCUE HOIST KIT	WITH SINGLE RESCUE HOIST KIT	-	-
	259100M-03	LU	LUBRICATION OF THE HOIST CABLE, HOIST BALL SPLINE SHAFT AND LEVEL WIND SCREW INTERVAL NOTE: 1 MH OR 3 HOURS OF HOIST OPERATION	MSI	NOTE	-	5 ; 6	WITH SINGLE RESCUE HOIST KIT	WITH SINGLE RESCUE HOIST KIT	-	-
	259100M-04	FC	FUNCTIONAL CHECK (DIMENSIONAL CHECK) OF HOIST CABLE INTERVAL NOTE: 1 MH OR 3 HOURS OF HOIST OPERATION	MSI	NOTE	-	5	WITH SINGLE RESCUE HOIST KIT	WITH SINGLE RESCUE HOIST KIT	-	-
	259100M-05	DI	DETAILED INSPECTION OF THE HOIST HOOK ASSEMBLY	MSI	3 MH	-	5	WITH SINGLE RESCUE HOIST KIT	WITH SINGLE RESCUE HOIST KIT	-	-

© Copyright 2024 Leonardo S.p.a.

This document contains information that is confidential and proprietary to Leonardo S.p.a. ('the Company') and is supplied on the express condition that it may not be disclosed to any third party, or reproduced in whole or in part, or used for manufacture, or used for any purpose other than for which it is supplied, without the prior written consent of the Company. Every permitted disclosure, reproduction, adaptation or publication of this document in whole or in part and in any manner or form shall prominently contain this notice



AW189 Maintenance Review Board Report

189G0000M006

Issue V

Page 77 of 275

REVISION STATUS	MRB-R TASK NUMBER	TASK CODE	TASK TITLE	SOURCE	INTERVAL	SAMPLING	FEC	APPLICABILITY		ZONE	ACCESS & REMARKS
								AW189	AW189ER		
	259100M-06	DIS	DISCARD HOIST CABLE CUTTER CARTRIDGE INTERVAL NOTE: 5 YR FROM MANUFACTURING	MSI	NOTE	-	8	WITH SINGLE RESCUE HOIST KIT	WITH SINGLE RESCUE HOIST KIT	-	-
	259100M-07	OC	OPERATIONAL CHECK OF THE HOIST CABLE CUT SWITCHES	MSI	1 YR	-	8	WITH SINGLE RESCUE HOIST KIT	WITH SINGLE RESCUE HOIST KIT	-	-
	259100M-08	GVI	GENERAL VISUAL INSPECTION OF MANUAL CABLE CUTTER	MSI	1 YR	-	8	WITH SINGLE RESCUE HOIST KIT	WITH SINGLE RESCUE HOIST KIT	-	-
	259100M-09	-	TASK DELETED WITH MRBR ISSUE C	-	-	-	-	-	-	-	-

© Copyright 2024 Leonardo S.p.a.

This document contains information that is confidential and proprietary to Leonardo S.p.a. ('the Company') and is supplied on the express condition that it may not be disclosed to any third party, or reproduced in whole or in part, or used for manufacture, or used for any purpose other than for which it is supplied, without the prior written consent of the Company. Every permitted disclosure, reproduction, adaptation or publication of this document in whole or in part and in any manner or form shall prominently contain this notice



AW189 Maintenance Review Board Report

189G0000M006

Issue V

Page 78 of 275

REVISION STATUS	MRB-R TASK NUMBER	TASK CODE	TASK TITLE	SOURCE	INTERVAL	SAMPLING	FEC	APPLICABILITY		ZONE	ACCESS & REMARKS
								AW189	AW189ER		
	259100M-10	RST	RESTORATION (OVERHAUL) OF HOIST ASSEMBLY OFF AIRCRAFT INTERVAL NOTE: 10 YR or 111 HOURS OF HOIST OPERATION	MSI	NOTE	-	5 ; 8	WITH SINGLE RESCUE HOIST KIT	WITH SINGLE RESCUE HOIST KIT	-	-
	259100M-11	OC	OPERATIONAL CHECK OF HOIST LIMIT SWITCH ASSEMBLY INTERVAL NOTE: 52 HOURS OF HOIST OPERATION OR 6 MH	MSI	NOTE	-	8	WITH SINGLE RESCUE HOIST KIT	WITH SINGLE RESCUE HOIST KIT	-	-
	259100M-12	OC	OPERATIONAL CHECK OF HOIST CABLE ANTI-FOUL ASSEMBLY INTERVAL NOTE: 52 HOURS OF HOIST OPERATION OR 6 MH	MSI	NOTE	-	9	WITH SINGLE RESCUE HOIST KIT	WITH SINGLE RESCUE HOIST KIT	-	-
	259100M-13	GVI	GENERAL VISUAL INSPECTION OF THE HOIST OPERATOR HARNES / TETHER	MSI	120 DY	-	5	WITH SINGLE RESCUE HOIST KIT	WITH SINGLE RESCUE HOIST KIT	-	-

© Copyright 2024 Leonardo S.p.a.

This document contains information that is confidential and proprietary to Leonardo S.p.a. ('the Company') and is supplied on the express condition that it may not be disclosed to any third party, or reproduced in whole or in part, or used for manufacture, or used for any purpose other than for which it is supplied, without the prior written consent of the Company. Every permitted disclosure, reproduction, adaptation or publication of this document in whole or in part and in any manner or form shall prominently contain this notice



AW189 Maintenance Review Board Report

189G0000M006

Issue V

Page 79 of 275

REVISION STATUS	MRB-R TASK NUMBER	TASK CODE	TASK TITLE	SOURCE	INTERVAL	SAMPLING	FEC	APPLICABILITY		ZONE	ACCESS & REMARKS
								AW189	AW189ER		
	259100M-14	DI	DETAILED INSPECTION OF THE CABIN CEILING HOOKS	MSI	2 YR	-	5	WITH SINGLE RESCUE HOIST KIT	WITH SINGLE RESCUE HOIST KIT	-	-
	259100M-15	GVI	GENERAL VISUAL INSPECTION OF THE WINCHMAN HARNESS	MSI	30 DY	-	5	WITH SINGLE RESCUE HOIST KIT	WITH SINGLE RESCUE HOIST KIT	-	-
	259100M-16	DIS	DISCARD THE WINCHMAN HARNESS. INTERVAL NOTE: 7 YR FROM ENTRY INTO SERVICE ; 10 YR FROM MANUFACTURING	MSI	NOTE	-	5	WITH SINGLE RESCUE HOIST KIT	WITH SINGLE RESCUE HOIST KIT	-	-
	259100M-17	DI	DETAILED INSPECTION OF THE HOIST ASSEMBLY MOUNTING AND FAIRING	MSI	2 YR	-	5; 9	WITH SINGLE RESCUE HOIST KIT	WITH SINGLE RESCUE HOIST KIT	-	-

© Copyright 2024 Leonardo S.p.a.

This document contains information that is confidential and proprietary to Leonardo S.p.a. ('the Company') and is supplied on the express condition that it may not be disclosed to any third party, or reproduced in whole or in part, or used for manufacture, or used for any purpose other than for which it is supplied, without the prior written consent of the Company. Every permitted disclosure, reproduction, adaptation or publication of this document in whole or in part and in any manner or form shall prominently contain this notice



AW189 Maintenance Review Board Report

189G0000M006

Issue V

Page 80 of 275

REVISION STATUS	MRB-R TASK NUMBER	TASK CODE	TASK TITLE	SOURCE	INTERVAL	SAMPLING	FEC	APPLICABILITY		ZONE	ACCESS & REMARKS
								AW189	AW189ER		
	259100M-18	DI	DETAILED INSPECTION OF THE HOIST CABLE PATH	MSI	1 YR	-	6	WITH SINGLE RESCUE HOIST KIT	WITH SINGLE RESCUE HOIST KIT	-	-
	259100M-19	GVI	GENERAL VISUAL INSPECTION OF THE HOIST CABLE INTERVAL NOTE: 52 HOURS OF HOIST OPERATION OR 6 MH	MSI	NOTE	-	5	WITH SINGLE RESCUE HOIST KIT	WITH SINGLE RESCUE HOIST KIT	-	-
	259100M-20	DIS	DISCARD THE HOIST OPERATOR HARNESS AND TETHER NOTE: IDENTICAL TO 259300M-21	MSI	10 YR FROM MANUFACTURING	-	5	WITH SINGLE RESCUE HOIST KIT	WITH SINGLE RESCUE HOIST KIT	-	-
MSI 25-92-00: CARGO HOOK KIT											
	259200M-01	GVI	GENERAL VISUAL INSPECTION OF THE EXTERNAL CARGO HOOK ASSEMBLY COMPONENTS	MSI	800 FH ; 1 YR	-	6; 9	WITH CARGO HOOK KIT	WITH CARGO HOOK KIT	-	-

© Copyright 2024 Leonardo S.p.a.

This document contains information that is confidential and proprietary to Leonardo S.p.a. ('the Company') and is supplied on the express condition that it may not be disclosed to any third party, or reproduced in whole or in part, or used for manufacture, or used for any purpose other than for which it is supplied, without the prior written consent of the Company. Every permitted disclosure, reproduction, adaptation or publication of this document in whole or in part and in any manner or form shall prominently contain this notice



AW189 Maintenance Review Board Report

189G0000M006

Issue V

Page 81 of 275

REVISION STATUS	MRB-R TASK NUMBER	TASK CODE	TASK TITLE	SOURCE	INTERVAL	SAMPLING	FEC	APPLICABILITY		ZONE	ACCESS & REMARKS
								AW189	AW189ER		
	259200M-02	RST	RESTORATION (OVERHAUL) OF THE CARGO HOOK ASSEMBLY OFF AIRCRAFT INTERVAL NOTE: 5 YR OR EVERY 1500 EXTERNAL LOAD CYCLES	MSI	NOTE	-	6 ; 8; 9	WITH CARGO HOOK KIT	WITH CARGO HOOK KIT	-	-
	259200M-03	OC	OPERATIONAL CHECK OF CARGO HOOK EMERGENCY RELEASE FUNCTION	MSI	1 YR	-	8	WITH CARGO HOOK KIT	WITH CARGO HOOK KIT	-	-
	259200M-04	DIS	DISCARD CARGO HOOK PRESSURE CARTRIDGE INTERVAL NOTE: 13 YR FROM MANUFACTURING, 5 YR FROM FIRST INSTALLATION	MSI	NOTE	-	8	WITH CARGO HOOK KIT	WITH CARGO HOOK KIT	-	-

© Copyright 2024 Leonardo S.p.a.

This document contains information that is confidential and proprietary to Leonardo S.p.a. ('the Company') and is supplied on the express condition that it may not be disclosed to any third party, or reproduced in whole or in part, or used for manufacture, or used for any purpose other than for which it is supplied, without the prior written consent of the Company. Every permitted disclosure, reproduction, adaptation or publication of this document in whole or in part and in any manner or form shall prominently contain this notice



AW189 Maintenance Review Board Report

189G0000M006

Issue V

Page 82 of 275

REVISION STATUS	MRB-R TASK NUMBER	TASK CODE	TASK TITLE	SOURCE	INTERVAL	SAMPLING	FEC	APPLICABILITY		ZONE	ACCESS & REMARKS
								AW189	AW189ER		
	259200M-05	OC	OPERATIONAL CHECK OF CARGO HOOK RELATCH MECHANISM	MSI	1 YR	-	9	WITH CARGO HOOK KIT	WITH CARGO HOOK KIT	-	-
MSI 25-93-00: DUAL RESCUE HOIST											
	259300M-01	GVI	GENERAL VISUAL INSPECTION OF HOIST OIL LEVEL INTERVAL NOTE: 1 MH OR 3 HOURS OF HOIST OPERATION	MSI	NOTE	-	6	WITH DUAL RESCUE HOIST KIT	WITH DUAL RESCUE HOIST KIT	-	-
	259300M-02	SV	SERVICING (OIL REPLACEMENT) OF HOIST ASSEMBLY	MSI	6 MH ; 400 HOIST LIFTS	-	6	WITH DUAL RESCUE HOIST KIT	WITH DUAL RESCUE HOIST KIT	-	-
	259300M-03	LU	LUBRICATION OF HOIST CABLE, HOIST BALL SPLINE SHAFT AND LEVEL WIND SCREW INTERVAL NOTE: 1 MH OR 3 HOURS OF HOIST OPERATION	MSI	NOTE	-	8; 6	WITH DUAL RESCUE HOIST KIT	WITH DUAL RESCUE HOIST KIT	-	-

© Copyright 2024 Leonardo S.p.a.

This document contains information that is confidential and proprietary to Leonardo S.p.a. ('the Company') and is supplied on the express condition that it may not be disclosed to any third party, or reproduced in whole or in part, or used for manufacture, or used for any purpose other than for which it is supplied, without the prior written consent of the Company. Every permitted disclosure, reproduction, adaptation or publication of this document in whole or in part and in any manner or form shall prominently contain this notice



AW189 Maintenance Review Board Report

189G0000M006

Issue V

Page 83 of 275

REVISION STATUS	MRB-R TASK NUMBER	TASK CODE	TASK TITLE	SOURCE	INTERVAL	SAMPLING	FEC	APPLICABILITY		ZONE	ACCESS & REMARKS
								AW189	AW189ER		
	259300M-04	FC	FUNCTIONAL CHECK (DIMENSIONAL CHECK) OF HOIST CABLE INTERVAL NOTE: 1 MH, OR 3 HOURS OF HOIST OPERATION	MSI	NOTE	-	8	WITH DUAL RESCUE HOIST KIT	WITH DUAL RESCUE HOIST KIT	-	-
	259300M-05	DI	DETAILED INSPECTION OF HOOK ASSEMBLY	MSI	3 MH	-	8	WITH DUAL RESCUE HOIST KIT	WITH DUAL RESCUE HOIST KIT	-	-
	259300M-06	DIS	DISCARD HOIST ASSEMBLY CABLE CUTTER CARTRIDGE INTERVAL NOTE: 5 YR FROM MANUFACTURING	MSI	NOTE	-	8 ; 9	WITH DUAL RESCUE HOIST KIT	WITH DUAL RESCUE HOIST KIT	-	-
	259300M-07	OC	OPERATIONAL CHECK OF THE HOIST CABLE CUT SWITCHES	MSI	1 YR	-	8; 9	WITH DUAL RESCUE HOIST KIT	WITH DUAL RESCUE HOIST KIT	-	-
	259300M-08	GVI	GENERAL VISUAL INSPECTION OF MANUAL CABLE CUTTER	MSI	1 YR	-	8; 9	WITH DUAL RESCUE HOIST KIT	WITH DUAL RESCUE HOIST KIT	-	-

© Copyright 2024 Leonardo S.p.a.

This document contains information that is confidential and proprietary to Leonardo S.p.a. ('the Company') and is supplied on the express condition that it may not be disclosed to any third party, or reproduced in whole or in part, or used for manufacture, or used for any purpose other than for which it is supplied, without the prior written consent of the Company. Every permitted disclosure, reproduction, adaptation or publication of this document in whole or in part and in any manner or form shall prominently contain this notice



AW189 Maintenance Review Board Report

189G0000M006

Issue V

Page 84 of 275

REVISION STATUS	MRB-R TASK NUMBER	TASK CODE	TASK TITLE	SOURCE	INTERVAL	SAMPLING	FEC	APPLICABILITY		ZONE	ACCESS & REMARKS
								AW189	AW189ER		
	259300M-09	-	TASK DELETED WITH MRBR ISSUE C	-	-	-	-	-	-	-	-
	259300M-10	RST	RESTORATION (OVERHAUL) OF HOIST ASSEMBLY OFF AIRCRAFT INTERVAL NOTE: 10 YR OR 111 HOIST OPERATING HOURS	MSI	NOTE	-	8 ; 9	WITH DUAL RESCUE HOIST KIT	WITH DUAL RESCUE HOIST KIT	-	-
	259300M-11	OC	OPERATIONAL CHECK OF DUAL HOIST LIMIT SWITCH ASSEMBLY INTERVAL NOTE: 52 HOURS OF HOIST OPERATION OR 6 MH	MSI	NOTE	-	8	WITH DUAL RESCUE HOIST KIT	WITH DUAL RESCUE HOIST KIT	-	-
	259300M-12	DI	DETAILED INSPECTION OF HOIST ASSEMBLY MOUNTING AND FAIRING	MSI	2 YR	-	8; 9	WITH DUAL RESCUE HOIST KIT	WITH DUAL RESCUE HOIST KIT	-	-

© Copyright 2024 Leonardo S.p.a.

This document contains information that is confidential and proprietary to Leonardo S.p.a. ('the Company') and is supplied on the express condition that it may not be disclosed to any third party, or reproduced in whole or in part, or used for manufacture, or used for any purpose other than for which it is supplied, without the prior written consent of the Company. Every permitted disclosure, reproduction, adaptation or publication of this document in whole or in part and in any manner or form shall prominently contain this notice



AW189 Maintenance Review Board Report

189G0000M006

Issue V

Page 85 of 275

REVISION STATUS	MRB-R TASK NUMBER	TASK CODE	TASK TITLE	SOURCE	INTERVAL	SAMPLING	FEC	APPLICABILITY		ZONE	ACCESS & REMARKS
								AW189	AW189ER		
R	259300M-13	LU	LUBRICATION OF AXELCUT MANUAL CABLE CUTTER	MSI	6 MH	-	8; 9	WITH ANY KIT INSTALLING AXELCUT MANUAL CABLE CUTTER	WITH ANY KIT INSTALLING AXELCUT MANUAL CABLE CUTTER	-	-
	259300M-14	GVI	GENERAL VISUAL INSPECTION OF HOIST OPERATOR HARNESS / TETHER	MSI	120 DY	-	5	WITH DUAL RESCUE HOIST KIT	WITH DUAL RESCUE HOIST KIT	-	-
	259300M-15	DI	DETAILED INSPECTION OF CABIN CEILING HOOKS	MSI	2 YR	-	5	WITH DUAL RESCUE HOIST KIT	WITH DUAL RESCUE HOIST KIT	-	-
	259300M-16	GVI	GENERAL VISUAL INSPECTION OF WINCHMAN HARNESS	MSI	30 DY	-	5	WITH DUAL RESCUE HOIST KIT	WITH DUAL RESCUE HOIST KIT	-	-
	259300M-17	DIS	DISCARD THE WINCHMAN HARNESS. INTERVAL NOTE: 7 YR FROM ENTRY INTO SERVICE ; 10 YR FROM MANUFACTURING	MSI	NOTE	-	5	WITH DUAL RESCUE HOIST KIT	WITH DUAL RESCUE HOIST KIT	-	-

© Copyright 2024 Leonardo S.p.a.

This document contains information that is confidential and proprietary to Leonardo S.p.a. ('the Company') and is supplied on the express condition that it may not be disclosed to any third party, or reproduced in whole or in part, or used for manufacture, or used for any purpose other than for which it is supplied, without the prior written consent of the Company. Every permitted disclosure, reproduction, adaptation or publication of this document in whole or in part and in any manner or form shall prominently contain this notice



AW189 Maintenance Review Board Report

189G0000M006

Issue V

Page 86 of 275

REVISION STATUS	MRB-R TASK NUMBER	TASK CODE	TASK TITLE	SOURCE	INTERVAL	SAMPLING	FEC	APPLICABILITY		ZONE	ACCESS & REMARKS
								AW189	AW189ER		
	259300M-18	OC	OPERATIONAL CHECK OF HOIST CABLE ANTI-FOUL ASSEMBLY INTERVAL NOTE: 52 HOURS OF HOIST OPERATION OR 6 MH	MSI	NOTE	-	9	WITH DUAL RESCUE HOIST KIT	WITH DUAL RESCUE HOIST KIT		
	259300M-19	DI	DETAILED INSPECTION OF THE HOIST CABLE PATH	MSI	1 YR	-	6	WITH DUAL RESCUE HOIST KIT	WITH DUAL RESCUE HOIST KIT	-	-
	259300M-20	GVI	GENERAL VISUAL INSPECTION OF THE HOIST CABLE INTERVAL NOTE: 52 HOURS OF HOIST OPERATION OR 6 MH	MSI	NOTE	-	8	WITH DUAL RESCUE HOIST KIT	WITH DUAL RESCUE HOIST KIT	-	-

© Copyright 2024 Leonardo S.p.a.

This document contains information that is confidential and proprietary to Leonardo S.p.a. ('the Company') and is supplied on the express condition that it may not be disclosed to any third party, or reproduced in whole or in part, or used for manufacture, or used for any purpose other than for which it is supplied, without the prior written consent of the Company. Every permitted disclosure, reproduction, adaptation or publication of this document in whole or in part and in any manner or form shall prominently contain this notice



AW189 Maintenance Review Board Report

189G0000M006

Issue V

Page 87 of 275

REVISION STATUS	MRB-R TASK NUMBER	TASK CODE	TASK TITLE	SOURCE	INTERVAL	SAMPLING	FEC	APPLICABILITY		ZONE	ACCESS & REMARKS
								AW189	AW189ER		
	259300M-21	DIS	DISCARD THE HOIST OPERATOR HARNESS AND TETHER NOTE: IDENTICAL TO 259100M-20	MSI	10 YR FROM MANUFACTURING	-	5	WITH DUAL RESCUE HOIST KIT	WITH DUAL RESCUE HOIST KIT	-	-
MSI 25-98-00: CABIN CEILING RINGS											
R	259800M-01	GVI	GENERAL VISUAL INSPECTION OF CABIN CEILING RINGS AND HANDLES	MSI	2 YR	-	9	WITH CABIN CEILING RINGS (CABIN ROOF HARD POINTS) KIT OR WITH INTERNAL HAND HOLD KIT OR SAFETY HOOKS INSTALLATION	WITH CABIN CEILING RINGS (CABIN ROOF HARD POINTS) KIT OR WITH INTERNAL HAND HOLD KIT OR SAFETY HOOKS INSTALLATION	-	-
	259800M-02	DI	DETAILED INSPECTION OF CABIN CEILING HOOKS	MSI	2 YR	-	5	WITH CABIN CEILING SAFETY HOOKS KIT	WITH CABIN CEILING SAFETY HOOKS KIT	-	-

© Copyright 2024 Leonardo S.p.a.

This document contains information that is confidential and proprietary to Leonardo S.p.a. ('the Company') and is supplied on the express condition that it may not be disclosed to any third party, or reproduced in whole or in part, or used for manufacture, or used for any purpose other than for which it is supplied, without the prior written consent of the Company. Every permitted disclosure, reproduction, adaptation or publication of this document in whole or in part and in any manner or form shall prominently contain this notice



AW189 Maintenance Review Board Report

189G0000M006

Issue V

Page 88 of 275

REVISION STATUS	MRB-R TASK NUMBER	TASK CODE	TASK TITLE	SOURCE	INTERVAL	SAMPLING	FEC	APPLICABILITY		ZONE	ACCESS & REMARKS
								AW189	AW189ER		
	259800M-03	DI	DETAILED INSPECTION OF CEILING REINFORCED HARD POINTS RINGS	MSI	2 YR	-	5	AW189 WITH CABIN REINFORCED HARD POINTS KIT	AW189 WITH CABIN REINFORCED HARD POINTS KIT	-	-
ATA 26: FIRE PROTECTION											
MSI 26-10-00: DETECTION											
	261000M-01	OC	OPERATIONAL CHECK OF THE ENGINE AND APU FIRE DETECTION SENSORS	MSI	3200 FH ; 8 YR	-	8	YES	YES	-	-
	261000M-02	OC	OPERATIONAL CHECK OF BAGGAGE COMPARTMENT SMOKE DETECTOR	MSI	3200 FH ; 8 YR	-	8	YES	YES	-	-
	261000M-03	DI	DETAILED INSPECTION OF THE FIRE DETECTION SENSOR IN THE ENGINE BAY INTERVAL NOTE: TO BE ACCOMPLISHED AT ENGINE REMOVAL	MSI	NOTE	-	6	YES	YES	-	-

© Copyright 2024 Leonardo S.p.a.

This document contains information that is confidential and proprietary to Leonardo S.p.a. ('the Company') and is supplied on the express condition that it may not be disclosed to any third party, or reproduced in whole or in part, or used for manufacture, or used for any purpose other than for which it is supplied, without the prior written consent of the Company. Every permitted disclosure, reproduction, adaptation or publication of this document in whole or in part and in any manner or form shall prominently contain this notice



AW189 Maintenance Review Board Report

189G0000M006

Issue V

Page 89 of 275

REVISION STATUS	MRB-R TASK NUMBER	TASK CODE	TASK TITLE	SOURCE	INTERVAL	SAMPLING	FEC	APPLICABILITY		ZONE	ACCESS & REMARKS
								AW189	AW189ER		
	261000M-04	DI	DETAILED INSPECTION OF THE FIRE DETECTION SENSOR IN THE APU BAY INTERVAL NOTE: TO BE ACCOMPLISHED AT APU REMOVAL	MSI	NOTE	-	6	YES	YES	-	-
MSI 26-20-00: EXTINGUISHING											
	262000M-01	-	TASK DELETED WITH MRBR. IS.N	-	-	-	-	-	-	-	-
	262000M-02	DIS	DISCARD FIRE BOTTLES CARTRIDGE INTERVAL NOTE: NOT EXCEEDING 15 YR FROM MANUFACTURING	MSI	12YR; NOTE	-	8	WITH CT7-2E1 ENGINE INSTALLATION	WITH CT7-2E1 ENGINE INSTALLATION	-	-

© Copyright 2024 Leonardo S.p.a.

This document contains information that is confidential and proprietary to Leonardo S.p.a. ('the Company') and is supplied on the express condition that it may not be disclosed to any third party, or reproduced in whole or in part, or used for manufacture, or used for any purpose other than for which it is supplied, without the prior written consent of the Company. Every permitted disclosure, reproduction, adaptation or publication of this document in whole or in part and in any manner or form shall prominently contain this notice



AW189 Maintenance Review Board Report

189G0000M006

Issue V

Page 90 of 275

REVISION STATUS	MRB-R TASK NUMBER	TASK CODE	TASK TITLE	SOURCE	INTERVAL	SAMPLING	FEC	APPLICABILITY		ZONE	ACCESS & REMARKS
								AW189	AW189ER		
	262000M-03	FC	FUNCTIONAL CHECK (WEIGHT CHECK) OF PORTABLE FIRE EXTINGUISHERS OFF AIRCRAFT NOTE: SHOULD BE ACCOMPLISHED IN CONJUNCTION WITH 262000M-10	MSI	1 YR	-	8	YES	YES	-	-
	262000M-04	DIS	DISCARD PORTABLE FIRE EXTINGUISHERS INTERVAL NOTE: 10 YEARS FROM MANUFACTURING FOR FIRE FIGHTING ENTERPRISES LTD. 6 YEARS FROM MANUFACTURING FOR H3R 12 YEARS FROM MANUFACTURING FOR P3 HAFEX	MSI	NOTE	-	8	YES	YES	-	-

© Copyright 2024 Leonardo S.p.a.

This document contains information that is confidential and proprietary to Leonardo S.p.a. ('the Company') and is supplied on the express condition that it may not be disclosed to any third party, or reproduced in whole or in part, or used for manufacture, or used for any purpose other than for which it is supplied, without the prior written consent of the Company. Every permitted disclosure, reproduction, adaptation or publication of this document in whole or in part and in any manner or form shall prominently contain this notice



AW189 Maintenance Review Board Report

189G0000M006

Issue V

Page 91 of 275

REVISION STATUS	MRB-R TASK NUMBER	TASK CODE	TASK TITLE	SOURCE	INTERVAL	SAMPLING	FEC	APPLICABILITY		ZONE	ACCESS & REMARKS
								AW189	AW189ER		
	262000M-05	OC	OPERATIONAL CHECK OF ENGINE / APU BLEED AIR AND FUEL SHUT OFF VALVES NOTE: COVERS 282000M-01 AND 282100M-01	MSI	1600 FH ; 2 YR	-	8	YES	YES	-	-
	262000M-06	OC	OPERATIONAL CHECK OF THE FIRE EXTINGUISHING DISTRIBUTION PIPEWORK (ENGINES / APU)	MSI	1 YR	-	8	YES	YES	-	-
	262000M-07	FC	FUNCTIONAL CHECK (BALL SEAL BEHAVIOUR) OF FIRE PROTECTION "TEE" CHECK VALVE OFF AIRCRAFT	MSI	1 YR	-	8	YES	YES	-	-
	262000M-08	OC	OPERATIONAL CHECK OF TEMPERATURE COMPENSATED PRESSURE SWITCH (TCPS) PRESSURE INDICATION CIRCUITS	MSI	1 YR	-	9	YES	YES	-	-
	262000M-09	DI	DETAILED INSPECTION OF ENGINE / APU FIRE EXTINGUISHER BOTTLES AND DISCHARGE OUTLET VALVES	MSI	5 YR	-	6	YES	YES	-	-

© Copyright 2024 Leonardo S.p.a.

This document contains information that is confidential and proprietary to Leonardo S.p.a. ('the Company') and is supplied on the express condition that it may not be disclosed to any third party, or reproduced in whole or in part, or used for manufacture, or used for any purpose other than for which it is supplied, without the prior written consent of the Company. Every permitted disclosure, reproduction, adaptation or publication of this document in whole or in part and in any manner or form shall prominently contain this notice



AW189 Maintenance Review Board Report

189G0000M006

Issue V

Page 92 of 275

REVISION STATUS	MRB-R TASK NUMBER	TASK CODE	TASK TITLE	SOURCE	INTERVAL	SAMPLING	FEC	APPLICABILITY		ZONE	ACCESS & REMARKS
								AW189	AW189ER		
	262000M-10	DI	DETAILED INSPECTION OF PORTABLE FIRE EXTINGUISHERS NOTE: SHOULD BE ACCOMPLISHED IN CONJUNCTION WITH 262000M-03	MSI	1 YR	-	8	WITH FIRE FIGHTING ENTERPRISES LTD PORTABLE FIRE EXTINGUISHER	WITH FIRE FIGHTING ENTERPRISES LTD PORTABLE FIRE EXTINGUISHER	-	-
	262000M-11	OC	OPERATIONAL CHECK OF ENGINES AND APU FIRE EXTINGUISHING FIRING CIRCUITS	MSI	1600 FH ; 2 YR	-	8	YES	YES	-	-
	262000M-12	GVI	GENERAL VISUAL INSPECTION OF ENGINE FIRE EXTINGUISHER BOTTLES MOUNTINGS	MSI	1 YR	-	9	YES	YES	-	-
	262000M-13	VC	VISUAL CHECK OF PORTABLE FIRE EXTINGUISHER	MSI	1 MH	-	8	WITH H3R OR P3 HAFEX PORTABLE FIRE EXTINGUISHER	WITH H3R OR P3 HAFEX PORTABLE FIRE EXTINGUISHER	-	-
	262000M-14	DIS	DISCARD FIRE BOTTLES CARTRIDGE INTERVAL NOTE: NOT EXCEEDING 15 YR FROM MANUFACTURING	MSI	10 YR; NOTE	-	8	WITH ANETO-1K ENGINE INSTALLATION	NO	-	-

ATA 28: FUEL

© Copyright 2024 Leonardo S.p.a.

This document contains information that is confidential and proprietary to Leonardo S.p.a. ('the Company') and is supplied on the express condition that it may not be disclosed to any third party, or reproduced in whole or in part, or used for manufacture, or used for any purpose other than for which it is supplied, without the prior written consent of the Company. Every permitted disclosure, reproduction, adaptation or publication of this document in whole or in part and in any manner or form shall prominently contain this notice



AW189 Maintenance Review Board Report

189G0000M006

Issue V

Page 93 of 275

REVISION STATUS	MRB-R TASK NUMBER	TASK CODE	TASK TITLE	SOURCE	INTERVAL	SAMPLING	FEC	APPLICABILITY		ZONE	ACCESS & REMARKS
								AW189	AW189ER		
MSI 28-10-00: FUEL STORAGE											
	281000M-01	DI	DETAILED INSPECTION OF FUEL TANK SUMP AREAS AND BAY DRAIN OUTLETS (MAIN FUEL TANKS AND FORWARD AUXILIARY IF INSTALLED)	MSI	800 FH	-	8	YES	NO	-	-
	-	-	TASK DELETED WITH MRBR ISS	-	-	-	-	-	-	-	-
MSI 28-11-00: FUEL STORAGE UNDERBELLY TANK											
	281100M-01	DI	DETAILED INSPECTION OF MAIN FUEL TANKS AND TRANSFER UNDERBELLY FUEL TANKS SUMP AREAS	MSI	800 FH ; 1 YR	-	8	NO	YES	-	-
	281100M-02	DI	DETAILED INSPECTION OF TRANSFER/REFUEL INTERCONNECTION FUEL HOSES NOTE: IDENTICAL TO 282100M-02 AND 288000M-03	MSI	800 FH ; 1 YR	-	8	NO	YES	-	-
MSI 28-20-00: FUEL DISTRIBUTION											

© Copyright 2024 Leonardo S.p.a.

This document contains information that is confidential and proprietary to Leonardo S.p.a. ('the Company') and is supplied on the express condition that it may not be disclosed to any third party, or reproduced in whole or in part, or used for manufacture, or used for any purpose other than for which it is supplied, without the prior written consent of the Company. Every permitted disclosure, reproduction, adaptation or publication of this document in whole or in part and in any manner or form shall prominently contain this notice



AW189 Maintenance Review Board Report

189G0000M006

Issue V

Page 94 of 275

REVISION STATUS	MRB-R TASK NUMBER	TASK CODE	TASK TITLE	SOURCE	INTERVAL	SAMPLING	FEC	APPLICABILITY		ZONE	ACCESS & REMARKS
								AW189	AW189ER		
	282000M-01	OC	OPERATIONAL CHECK OF FUEL SHUT OFF VALVES (SOV) AUTOMATIC CLOSURE FUNCTION NOTE: COVERED BY 262000M-05	MSI	1600 FH ; 2 YR	-	8	YES	NO	-	-
MSI 28-21-00: FUEL DISTRIBUTION UNDERBELLY TANK											
	282100M-01	OC	OPERATIONAL CHECK OF ENGINE / APU FUEL SHUT OFF VALVES NOTE: COVERED BY 262000M-05	MSI	1600 FH ; 2 YR	-	8	NO	YES	-	-
	282100M-02	DI	DETAILED INSPECTION OF TRANSFER/REFUEL INTERCONNECTION FUEL HOSES NOTE: IDENTICAL TO 281100M-02	MSI	800 FH ; 1 YR	-	8	NO	YES	-	-
MSI 28-40-00: FUEL INDICATING											
	284000M-01	-	TASK DELETED WITH MRBR ISSUE B	-	-	-	-	-	-	-	-
MSI 28-80-00: FUEL VENTING											

© Copyright 2024 Leonardo S.p.a.

This document contains information that is confidential and proprietary to Leonardo S.p.a. ('the Company') and is supplied on the express condition that it may not be disclosed to any third party, or reproduced in whole or in part, or used for manufacture, or used for any purpose other than for which it is supplied, without the prior written consent of the Company. Every permitted disclosure, reproduction, adaptation or publication of this document in whole or in part and in any manner or form shall prominently contain this notice



AW189 Maintenance Review Board Report

189G0000M006

Issue V

Page 95 of 275

REVISION STATUS	MRB-R TASK NUMBER	TASK CODE	TASK TITLE	SOURCE	INTERVAL	SAMPLING	FEC	APPLICABILITY		ZONE	ACCESS & REMARKS
								AW189	AW189ER		
	288000M-01	GVI	GENERAL VISUAL INSPECTION OF MAIN TANK VENT LINES	MSI	1600 FH ; 4 YR	-	8	YES	YES	-	-
	288000M-02	DI	DETAILED INSPECTION OF FLAME ARRESTOR NOTE: AS ALTERNATIVE A SPECIAL DETAILED INSPECTION (BOROSCOPE INSPECTION OF FLAME ARRESTOR FROM LOWER PART OF FUEL VENT LINE) COULD BE PERFORMED	MSI	1600 FH ; 4 YR	-	8	YES	YES	-	-
	288000M-03	DI	DETAILED INSPECTION OF TRANSFER/REFUEL INTERCONNECTION FUEL HOSES NOTE: IDENTICAL TO 281100M-02	MSI	800 FH ; 1 YR	-	8	NO	YES	-	-
	288000M-04	DI	DETAILED INSPECTION OF CENTRAL UNDERBELLY TANK VENT LINES FOR ATTACHMENT AND SECURITY OF CONNECTIONS	MSI	1600 FH ; 2 YR	-	8	NO	YES	-	-
ATA 29: HYDRAULIC POWER											

© Copyright 2024 Leonardo S.p.a.

This document contains information that is confidential and proprietary to Leonardo S.p.a. ('the Company') and is supplied on the express condition that it may not be disclosed to any third party, or reproduced in whole or in part, or used for manufacture, or used for any purpose other than for which it is supplied, without the prior written consent of the Company. Every permitted disclosure, reproduction, adaptation or publication of this document in whole or in part and in any manner or form shall prominently contain this notice



AW189 Maintenance Review Board Report

189G0000M006

Issue V

Page 96 of 275

REVISION STATUS	MRB-R TASK NUMBER	TASK CODE	TASK TITLE	SOURCE	INTERVAL	SAMPLING	FEC	APPLICABILITY		ZONE	ACCESS & REMARKS
								AW189	AW189ER		
MSI 29-10-00: HYDRAULIC MAIN											
	291000M-01	SV	SERVICING (HYDRAULIC FLUID REPLACEMENT) OF THE HYDRAULIC SYSTEM CIRCUIT 1 AND CIRCUIT 2	MSI	1600 FH ; 2 YR	-	6	YES	YES	-	-
	291000M-02	OC	OPERATIONAL CHECK OF POWER CONTROL MODULE (PCM) 1 FLIGHT CONTROL SHUT OFF VALVE	MSI	800 FH	-	9	YES	YES	-	-
	291000M-03	OC	OPERATIONAL CHECK OF POWER CONTROL MODULE (PCM) 2 FLIGHT CONTROL SHUT OFF VALVE	MSI	800 FH	-	9	YES	YES	-	-
	291000M-04	OC	OPERATIONAL CHECK OF POWER CONTROL MODULE (PCM) 2 UTILITY SHUT OFF VALVE AUTOMATIC ISOLATION FUNCTION NOTE: SHOULD BE ACCOMPLISHED IN CONJUNCTION WITH 293000M-01	MSI	800 FH	-	9	YES	YES	-	-

© Copyright 2024 Leonardo S.p.a.

This document contains information that is confidential and proprietary to Leonardo S.p.a. ('the Company') and is supplied on the express condition that it may not be disclosed to any third party, or reproduced in whole or in part, or used for manufacture, or used for any purpose other than for which it is supplied, without the prior written consent of the Company. Every permitted disclosure, reproduction, adaptation or publication of this document in whole or in part and in any manner or form shall prominently contain this notice



AW189 Maintenance Review Board Report

189G0000M006

Issue V

Page 97 of 275

REVISION STATUS	MRB-R TASK NUMBER	TASK CODE	TASK TITLE	SOURCE	INTERVAL	SAMPLING	FEC	APPLICABILITY		ZONE	ACCESS & REMARKS
								AW189	AW189ER		
	291000M-05	OC	OPERATIONAL CHECK OF POWER CONTROL MODULE (PCM) 1 UTILITY SHUT OFF VALVE AUTOMATIC ISOLATION FUNCTION NOTE: SHOULD BE ACCOMPLISHED IN CONJUNCTION WITH 293000M-01	MSI	800 FH	-	9	YES	YES	-	-
	291000M-06	OC	OPERATIONAL CHECK OF TAIL ROTOR SHUT OFF VALVE AUTOMATIC ISOLATION FUNCTION NOTE: SHOULD BE ACCOMPLISHED IN CONJUNCTION WITH 293000M-01	MSI	800 FH	-	9	YES	YES	-	-
	291000M-07	OC	OPERATIONAL CHECK OF POWER CONTROL MODULE (PCM) 1 HYDRAULIC VALVES	MSI	3200 FH	-	8	YES	YES	-	-
	291000M-08	OC	OPERATIONAL CHECK OF POWER CONTROL MODULE (PCM) 2 HYDRAULIC VALVES	MSI	3200 FH	-	8	YES	YES	-	-
MSI 29-30-00: INDICATING											

© Copyright 2024 Leonardo S.p.a.

This document contains information that is confidential and proprietary to Leonardo S.p.a. ('the Company') and is supplied on the express condition that it may not be disclosed to any third party, or reproduced in whole or in part, or used for manufacture, or used for any purpose other than for which it is supplied, without the prior written consent of the Company. Every permitted disclosure, reproduction, adaptation or publication of this document in whole or in part and in any manner or form shall prominently contain this notice



AW189 Maintenance Review Board Report

189G0000M006

Issue V

Page 98 of 275

REVISION STATUS	MRB-R TASK NUMBER	TASK CODE	TASK TITLE	SOURCE	INTERVAL	SAMPLING	FEC	APPLICABILITY		ZONE	ACCESS & REMARKS
								AW189	AW189ER		
	293000M-01	FC	FUNCTIONAL CHECK OF POWER CONTROL MODULE (PCM) 1 AND 2 MINIMUM LEVEL MONITORING NOTE: SHOULD BE ACCOMPLISHED IN CONJUNCTION WITH 291000M-01	MSI	1600 FH ; 2 YR	-	9	YES	YES	-	-
ATA 30: ICE AND RAIN PROTECTION											
MSI 30-01-00: LIMITED ICE PROTECTION SYSTEM KIT											
	300100M-01	DI	DETAILED INSPECTION OF ICE DETECTOR MEASURING HEAD OFF AIRCRAFT	MSI	800 FH ; 1 YR	-	6 ; 9	WITH LIPS KIT	WITH LIPS KIT	-	-
	300100M-02	RST	RESTORATION (OVERHAUL) OF IPS BLEED AIR SHUT-OFF VALVE OFF AIRCRAFT	MSI	10000 FH	-	6	WITH LIPS KIT	WITH LIPS KIT	-	-
MSI 30-02-00: FULL ICE PROTECTION SYSTEM											

© Copyright 2024 Leonardo S.p.a.

This document contains information that is confidential and proprietary to Leonardo S.p.a. ('the Company') and is supplied on the express condition that it may not be disclosed to any third party, or reproduced in whole or in part, or used for manufacture, or used for any purpose other than for which it is supplied, without the prior written consent of the Company. Every permitted disclosure, reproduction, adaptation or publication of this document in whole or in part and in any manner or form shall prominently contain this notice



AW189 Maintenance Review Board Report

189G0000M006

Issue V

Page 99 of 275

REVISION STATUS	MRB-R TASK NUMBER	TASK CODE	TASK TITLE	SOURCE	INTERVAL	SAMPLING	FEC	APPLICABILITY		ZONE	ACCESS & REMARKS
								AW189	AW189ER		
	300200M-01	DI	DETAILED INSPECTION OF ICE DETECTOR MEASURING HEAD OFF AIRCRAFT	MSI	800 FH ; 1 YR	-	9	WITH FIPS KIT	WITH FIPS KIT	-	-
	300200M-02	RST	RESTORATION (OVERHAUL) OF IPS BLEED AIR SHUT-OFF VALVE OFF AIRCRAFT	MSI	10000 FH	-	9	WITH FIPS KIT	WITH FIPS KIT	-	-
	300200M-03	RST	RESTORATION (OVERHAUL) OF FIPS XMS GENERATOR OFF AIRCRAFT	MSI	3000 FH	-	6	WITH FIPS KIT	WITH FIPS KIT	-	-
	300200M-04	RST	RESTORATION (OVERHAUL) OF FIPS MAIN ROTOR SLIP RING ASSEMBLY OFF AIRCRAFT	MSI	1500 FH	-	6	WITH FIPS KIT	WITH FIPS KIT	-	-
	300200M-05	DIS	DISCARD FIPS MAIN ROTOR SLIP RING ASSEMBLY	MSI	3000 FH	-	6	WITH FIPS KIT	WITH FIPS KIT	-	-

© Copyright 2024 Leonardo S.p.a.

This document contains information that is confidential and proprietary to Leonardo S.p.a. ('the Company') and is supplied on the express condition that it may not be disclosed to any third party, or reproduced in whole or in part, or used for manufacture, or used for any purpose other than for which it is supplied, without the prior written consent of the Company. Every permitted disclosure, reproduction, adaptation or publication of this document in whole or in part and in any manner or form shall prominently contain this notice



AW189 Maintenance Review Board Report

189G0000M006

Issue V

Page 100 of 275

REVISION STATUS	MRB-R TASK NUMBER	TASK CODE	TASK TITLE	SOURCE	INTERVAL	SAMPLING	FEC	APPLICABILITY		ZONE	ACCESS & REMARKS
								AW189	AW189ER		
	300200M-06	DI	DETAILED INSPECTION OF MAIN ROTOR HEAD FIPS COMPONENTS NOTE: SHOULD BE ACCOMPLISHED IN CONJUNCTION WITH <u>622000M-01</u>	MSI	400 FH	-	6	WITH FIPS KIT	WITH FIPS KIT	-	-
	300200M-07	GVI	GENERAL VISUAL INSPECTION OF CABINET COOLING DUCT	MSI	4 YR	-	9	WITH FIPS KIT	WITH FIPS KIT	-	-
	300200M-08	-	TASK DELETED WITH MRBR ISSUE H	-	-	-	-	-	-	-	-
	300200M-09	FC	FUNCTIONAL CHECK (WEAR MEASUREMENT) OF THE FIPS TAIL ROTOR SLIP RING ASSEMBLY BRUSH BLOCK	MSI	400 FH	-	6	WITH FIPS KIT	WITH FIPS KIT	-	-
	300200M-10	RST	RESTORATION (OVERHAUL) OF FIPS TAIL ROTOR SLIP RING ASSEMBLY OFF AIRCRAFT	MSI	1200 FH	-	6	WITH FIPS KIT	WITH FIPS KIT	-	-

© Copyright 2024 Leonardo S.p.a.

This document contains information that is confidential and proprietary to Leonardo S.p.a. ('the Company') and is supplied on the express condition that it may not be disclosed to any third party, or reproduced in whole or in part, or used for manufacture, or used for any purpose other than for which it is supplied, without the prior written consent of the Company. Every permitted disclosure, reproduction, adaptation or publication of this document in whole or in part and in any manner or form shall prominently contain this notice



AW189 Maintenance Review Board Report

189G0000M006

Issue V

Page 101 of 275

REVISION STATUS	MRB-R TASK NUMBER	TASK CODE	TASK TITLE	SOURCE	INTERVAL	SAMPLING	FEC	APPLICABILITY		ZONE	ACCESS & REMARKS
								AW189	AW189ER		
	300200M-11	DI	DETAILED INSPECTION OF TAIL ROTOR HEAD FIPS COMPONENTS NOTE: SHOULD BE ACCOMPLISHED IN CONJUNCTION WITH <u>641000M-01</u>	MSI	400 FH	-	6	WITH FIPS KIT	WITH FIPS KIT	-	-
	300200M-12	GVI	GENERAL VISUAL INSPECTION OF FIPS GENERATOR QUICK ATTACHMENT DEVICE (QAD)	MSI	400 FH	-	6	WITH FIPS KIT	WITH FIPS KIT	-	-
MSI 30-20-00: AIR INTAKES											
	302000M-01	DI	DETAIL INSPECTION OF AIR INTAKE CONTROLLERS SHOCK MOUNTS NOTE: APPLICABLE ONLY TO INSTALLATION P/N 8G7160P00511	MSI	1600 FH ; 2 YR	-	9	YES	YES	-	-
MSI 30-40-00: WINDOWS , WINDSHIELDS, CANOPIES & DOORS											
	304000M-01	GVI	GENERAL VISUAL INSPECTION OF WINDSHIELD WASHING COMPONENTS	MSI	1 YR	-	9	WITH WINDSHIELD WASHER KIT	WITH WINDSHIELD WASHER KIT	-	-

© Copyright 2024 Leonardo S.p.a.

This document contains information that is confidential and proprietary to Leonardo S.p.a. ('the Company') and is supplied on the express condition that it may not be disclosed to any third party, or reproduced in whole or in part, or used for manufacture, or used for any purpose other than for which it is supplied, without the prior written consent of the Company. Every permitted disclosure, reproduction, adaptation or publication of this document in whole or in part and in any manner or form shall prominently contain this notice



AW189 Maintenance Review Board Report

189G0000M006

Issue V

Page 102 of 275

REVISION STATUS	MRB-R TASK NUMBER	TASK CODE	TASK TITLE	SOURCE	INTERVAL	SAMPLING	FEC	APPLICABILITY		ZONE	ACCESS & REMARKS
								AW189	AW189ER		
MSI 30-70-00: WATER DRAINS											
	307000M-01	OC	OPERATIONAL CHECK OF MAIN GEARBOX FAN EXHAUST DUCT DRAIN AND DRAIN PIPE	MSI	1600 FH ; 2 YR	-	9	YES	YES	-	-
ATA 31: INDICATING / RECORDING SYSTEMS											
MSI 31-21-00: INDEPENDENT INSTRUMENT STAND-BY COMPASS											
	312100M-01	GVI	GENERAL VISUAL INSPECTION OF STAND-BY COMPASS	MSI	2 YR	-	6	YES	YES	-	-
MSI 31-31-00: COCKPIT VOICE/FLIGHT DATA RECORDER											
	313100M-01	FC	FUNCTIONAL CHECK (RECORDING FIDELITY) OF FLIGHT DATA RECORDER	MSI	2 YR	-	9	YES	YES	-	-
	313100M-02	OC	OPERATIONAL CHECK OF COCKPIT VOICE RECORDER SYSTEM	MSI	6 MH	-	9	YES	YES	-	-
	313100M-03	FC	FUNCTIONAL CHECK (VOLTAGE AND SIGNAL OUTPUT) OF FLIGHT DATA RECORDER (FDR) UNDERWATER LOCATOR BEACON (ULB)	MSI	6 MH	-	9	YES	YES	-	-

© Copyright 2024 Leonardo S.p.a.

This document contains information that is confidential and proprietary to Leonardo S.p.a. ('the Company') and is supplied on the express condition that it may not be disclosed to any third party, or reproduced in whole or in part, or used for manufacture, or used for any purpose other than for which it is supplied, without the prior written consent of the Company. Every permitted disclosure, reproduction, adaptation or publication of this document in whole or in part and in any manner or form shall prominently contain this notice



AW189 Maintenance Review Board Report

189G0000M006

Issue V

Page 103 of 275

REVISION STATUS	MRB-R TASK NUMBER	TASK CODE	TASK TITLE	SOURCE	INTERVAL	SAMPLING	FEC	APPLICABILITY		ZONE	ACCESS & REMARKS
								AW189	AW189ER		
	313100M-04	DIS	DISCARD UNDERWATER LOCATOR BEACON (ULB) BATTERY INTERVAL NOTE : EXPIRY DATE REPORTED ON THE ULB TAG	MSI	NOTE	-	9	YES	YES	-	-
	313100M-05	FC	FUNCTIONAL CHECK (FLIGHT DATA READ OUT) OF FLIGHT DATA RECORDER	MSI	1 YR	-	9	YES	YES	-	-
	313100M-06	OC	OPERATIONAL CHECK OF FLIGHT DATA RECORDER (FDR) AUTOMATIC STOP RECORDING LOGICS	MSI	1 YR	-	9	YES	YES	-	-
	313100M-07	FC	FUNCTIONAL CHECK OF RECORDER INDEPENDENT POWER SUPPLY (RIPS) INTERNAL TIMER	MSI	1 YR	-	9	YES	YES	-	-
ATA 32: LANDING GEAR											
MSI 32-10-00: MAIN GEAR											
	321000M-01	DI	DETAILED INSPECTION OF MLG SHOCK ABSORBERS	MSI	800 FH	-	5	YES	YES	-	-

© Copyright 2024 Leonardo S.p.a.

This document contains information that is confidential and proprietary to Leonardo S.p.a. ('the Company') and is supplied on the express condition that it may not be disclosed to any third party, or reproduced in whole or in part, or used for manufacture, or used for any purpose other than for which it is supplied, without the prior written consent of the Company. Every permitted disclosure, reproduction, adaptation or publication of this document in whole or in part and in any manner or form shall prominently contain this notice



AW189 Maintenance Review Board Report

189G0000M006

Issue V

Page 104 of 275

REVISION STATUS	MRB-R TASK NUMBER	TASK CODE	TASK TITLE	SOURCE	INTERVAL	SAMPLING	FEC	APPLICABILITY		ZONE	ACCESS & REMARKS
								AW189	AW189ER		
	321000M-02	DI	DETAILED INSPECTION OF MLG LEVERS AND TRAILING ARMS NOTE: ROTORCRAFT JACKED	MSI	800 FH	-	5 ; 6	YES	YES	-	-
	321000M-03	-	TASK DELETED WITH MRBR ISSUE E	-	-	-	-	-	-	-	-
	321000M-04	SV	SERVICING (N2 ADJUSTMENT) OF THE MLG SHOCK ABSORBERS NOTE: ROTORCRAFT JACKED	MSI	1600 FH	-	5 ; 6	YES	YES	-	-
	321000M-05	LU	LUBRICATION OF MLG NOTE: SHOULD BE ACCOMPLISHED IN CONJUNCTION WITH 321001S-01 AND WITH 322000M-04	MSI	400 FH ; 1 YR	-	5 ; 6	YES	YES	-	-
	321000M-06	DIS	DISCARD MLG SHOCK ABSORBERS	MSI	NOTE_C	-	5	YES	YES	-	-
	321000M-07	DIS	DISCARD MLG LEVERS	MSI	NOTE_C	-	5	YES	YES	-	-
	321000M-08	DIS	DISCARD MLG TRAILING ARMS	MSI	NOTE_C	-	5	YES	YES	-	-

© Copyright 2024 Leonardo S.p.a.

This document contains information that is confidential and proprietary to Leonardo S.p.a. ('the Company') and is supplied on the express condition that it may not be disclosed to any third party, or reproduced in whole or in part, or used for manufacture, or used for any purpose other than for which it is supplied, without the prior written consent of the Company. Every permitted disclosure, reproduction, adaptation or publication of this document in whole or in part and in any manner or form shall prominently contain this notice



AW189 Maintenance Review Board Report

189G0000M006

Issue V

Page 105 of 275

REVISION STATUS	MRB-R TASK NUMBER	TASK CODE	TASK TITLE	SOURCE	INTERVAL	SAMPLING	FEC	APPLICABILITY		ZONE	ACCESS & REMARKS
								AW189	AW189ER		
	321000M-09	SV	SERVICING (OIL REPLACEMENT) OF MLG SHOCK ABSORBER INTERVAL NOTE: 20000 RL AND THEN REPEAT EVERY 15000 RL OFF AIRCRAFT	MSI	NOTE	-	5 ; 6	YES	YES	-	-
MSI 32-20-00: NOSE GEAR											
	322000M-01	DI	DETAILED INSPECTION OF NLG SHOCK STRUT AND TORQUE LINKS	MSI	800 FH	-	5 ; 6	YES	YES	-	-
	322000M-02	DI	DETAILED INSPECTION OF NLG SHOCK ABSORBER	MSI	800 FH	-	5	YES	YES	-	-
	322000M-03	SV	SERVICING (N2 ADJUSTMENT) OF THE NLG SHOCK ABSORBER NOTE: ROTORCRAFT JACKED	MSI	1600 FH	-	5	YES	YES	-	-

© Copyright 2024 Leonardo S.p.a.

This document contains information that is confidential and proprietary to Leonardo S.p.a. ('the Company') and is supplied on the express condition that it may not be disclosed to any third party, or reproduced in whole or in part, or used for manufacture, or used for any purpose other than for which it is supplied, without the prior written consent of the Company. Every permitted disclosure, reproduction, adaptation or publication of this document in whole or in part and in any manner or form shall prominently contain this notice



AW189 Maintenance Review Board Report

189G0000M006

Issue V

Page 106 of 275

REVISION STATUS	MRB-R TASK NUMBER	TASK CODE	TASK TITLE	SOURCE	INTERVAL	SAMPLING	FEC	APPLICABILITY		ZONE	ACCESS & REMARKS
								AW189	AW189ER		
	322000M-04	LU	LUBRICATION OF NLG NOTE: SHOULD BE ACCOMPLISHED IN CONJUNCTION WITH 321000M-05	MSI	400 FH ; 1 YR	-	5 ; 6	YES	YES	-	-
	322000M-05	DIS	DISCARD NLG SHOCK STRUT (INCLUDING SHOCK ABSORBER)	MSI	NOTE_C	-	5	YES	YES	-	-
	322000M-06	GVI	GENERAL VISUAL INSPECTION OF NLG SHOCK STRUT SHEAR PLATE NUT LOCKING WIRE APPLICABILITY NOTE: ONLY TO P/N 8G3220V00231	MSI	4000 RL	-	5	NOTE	NOTE	-	-
	322000M-07	SV	SERVICING (OIL REPLACEMENT) OF NLG SHOCK ABSORBER OFF AIRCRAFT INTERVAL NOTE: 40000 RL FROM FIRST INSTALLATION, 20000 RL FROM LAST SERVICING	MSI	NOTE	-	5	YES	YES	-	-

© Copyright 2024 Leonardo S.p.a.

This document contains information that is confidential and proprietary to Leonardo S.p.a. ('the Company') and is supplied on the express condition that it may not be disclosed to any third party, or reproduced in whole or in part, or used for manufacture, or used for any purpose other than for which it is supplied, without the prior written consent of the Company. Every permitted disclosure, reproduction, adaptation or publication of this document in whole or in part and in any manner or form shall prominently contain this notice



AW189 Maintenance Review Board Report

189G0000M006

Issue V

Page 107 of 275

REVISION STATUS	MRB-R TASK NUMBER	TASK CODE	TASK TITLE	SOURCE	INTERVAL	SAMPLING	FEC	APPLICABILITY		ZONE	ACCESS & REMARKS
								AW189	AW189ER		
MSI 32-30-00: EXTENSION & RETRACTION / EMERGENCY LOWERING											
	323000M-01	GVI	GENERAL VISUAL INSPECTION OF LANDING GEAR CONTROL VALVE	MSI	400 FH ; 1 YR	-	6	YES	YES	-	-
	323000M-02	GVI	GENERAL VISUAL INSPECTION OF LANDING GEAR RETRACTION ACTUATOR	MSI	400 FH ; 1 YR	-	5 ; 6 ; 8	YES	YES	-	-
	323000M-03	FC	FUNCTIONAL CHECK (RETRACTION EXTENSION TIME) OF LANDING GEAR IN NORMAL OPERATION NOTE 1: ROTORCRAFT JACKED NOTE 2: SHOULD BE ACCOMPLISHED IN CONJUNCTION WITH 323000M-05 AND 326000M-01	MSI	1 YR	-	6	YES	YES	-	-
	323000M-04	OC	OPERATIONAL CHECK OF THE LANDING GEAR CONTROL PANEL (LGCP) LEVER LOCK MECHANISM NOTE: ROTORCRAFT JACKED	MSI	1 YR	-	8	YES	YES	-	-

© Copyright 2024 Leonardo S.p.a.

This document contains information that is confidential and proprietary to Leonardo S.p.a. ('the Company') and is supplied on the express condition that it may not be disclosed to any third party, or reproduced in whole or in part, or used for manufacture, or used for any purpose other than for which it is supplied, without the prior written consent of the Company. Every permitted disclosure, reproduction, adaptation or publication of this document in whole or in part and in any manner or form shall prominently contain this notice



AW189 Maintenance Review Board Report

189G0000M006

Issue V

Page 108 of 275

REVISION STATUS	MRB-R TASK NUMBER	TASK CODE	TASK TITLE	SOURCE	INTERVAL	SAMPLING	FEC	APPLICABILITY		ZONE	ACCESS & REMARKS
								AW189	AW189ER		
	323000M-05	OC	OPERATIONAL CHECK OF LANDING GEAR EMERGENCY EXTENSION FUNCTION NOTE 1: ROTORCRAFT JACKED NOTE 2: SHOULD BE ACCOMPLISHED IN CONJUNCTION WITH 323000M-03 AND 326000M-01	MSI	1 YR	-	8	YES	YES	-	-
	323000M-06	RST	RESTORATION (OVERHAUL) OF LANDING GEAR CONTROL VALVE APPLICABLE TO P/N 8G3230V00231 ONLY OFF AIRCRAFT	MSI	8000 RL	-	8	YES	YES	-	-

© Copyright 2024 Leonardo S.p.a.

This document contains information that is confidential and proprietary to Leonardo S.p.a. ('the Company') and is supplied on the express condition that it may not be disclosed to any third party, or reproduced in whole or in part, or used for manufacture, or used for any purpose other than for which it is supplied, without the prior written consent of the Company. Every permitted disclosure, reproduction, adaptation or publication of this document in whole or in part and in any manner or form shall prominently contain this notice



AW189 Maintenance Review Board Report

189G0000M006

Issue V

Page 109 of 275

REVISION STATUS	MRB-R TASK NUMBER	TASK CODE	TASK TITLE	SOURCE	INTERVAL	SAMPLING	FEC	APPLICABILITY		ZONE	ACCESS & REMARKS
								AW189	AW189ER		
	323000M-07	DIS	DISCARD LANDING GEAR CONTROL VALVE INTERVAL NOTE: 10000 FH APPLICABLE ONLY TO P/N 8G3230V00231; 160000 RL APPLICABLE ONLY TO P/N 8G3230V00232	MSI	NOTE	-	8	YES	YES	-	-
	323000M-08	RST	RESTORATION (OVERHAUL) OF MAIN LANDING GEAR RETRACTING ACTUATOR NOTE: APPLICABLE TO P/N 8G3210V00831 ONLY OFF AIRCRAFT	MSI	8000 RL	-	5	YES	YES	-	-
	323000M-09	RST	RESTORATION (OVERHAUL) OF NOSE LANDING GEAR RETRACTING ACTUATOR INTERVAL NOTE: 8000 RL FOR P/N 8G3220V00331 AND 8G3220V00332; 80000 RL FOR P/N 8G3220V00333 AND 8G3220V00334 OFF AIRCRAFT	MSI	NOTE	-	5	YES	YES	-	-

© Copyright 2024 Leonardo S.p.a.

This document contains information that is confidential and proprietary to Leonardo S.p.a. ('the Company') and is supplied on the express condition that it may not be disclosed to any third party, or reproduced in whole or in part, or used for manufacture, or used for any purpose other than for which it is supplied, without the prior written consent of the Company. Every permitted disclosure, reproduction, adaptation or publication of this document in whole or in part and in any manner or form shall prominently contain this notice



AW189 Maintenance Review Board Report

189G0000M006

Issue V

Page 110 of 275

REVISION STATUS	MRB-R TASK NUMBER	TASK CODE	TASK TITLE	SOURCE	INTERVAL	SAMPLING	FEC	APPLICABILITY		ZONE	ACCESS & REMARKS
								AW189	AW189ER		
	323000M-10	DIS	DISCARD MAIN LANDING GEAR RETRACTING ACTUATOR INTERVAL NOTE: 10000FH APPLICABLE ONLY TO P/N 8G3210V00831 AND NOTE_C APPLICABLE TO ALL P/N	MSI	NOTE	-	5	YES	YES	-	-
	323000M-11	DIS	DISCARD NOSE LANDING GEAR RETRACTING ACTUATOR	MSI	NOTE_C	-	5	YES	YES	-	-
MSI 32-40-00: WHEELS & BRAKES											
	324000M-01	DI	DETAILED INSPECTION OF NLG AND MLG WHEEL ASSY INTERVAL NOTE: TO BE ACCOMPLISHED AT TYRE REMOVAL	MSI	NOTE	-	6	YES	YES	-	-
	324000M-02	DI	DETAILED INSPECTION OF MLG INDICATION PINS (WITH PARKING BRAKE ENABLED)	MSI	400 FH	-	6 ; 9	YES	YES	-	-

© Copyright 2024 Leonardo S.p.a.

This document contains information that is confidential and proprietary to Leonardo S.p.a. ('the Company') and is supplied on the express condition that it may not be disclosed to any third party, or reproduced in whole or in part, or used for manufacture, or used for any purpose other than for which it is supplied, without the prior written consent of the Company. Every permitted disclosure, reproduction, adaptation or publication of this document in whole or in part and in any manner or form shall prominently contain this notice



AW189 Maintenance Review Board Report

189G0000M006

Issue V

Page 111 of 275

REVISION STATUS	MRB-R TASK NUMBER	TASK CODE	TASK TITLE	SOURCE	INTERVAL	SAMPLING	FEC	APPLICABILITY		ZONE	ACCESS & REMARKS
								AW189	AW189ER		
	324000M-03	LU	LUBRICATION (GREASING) OF NLG AND MLG WHEEL BEARINGS NOTE: SHOULD BE ACCOMPLISHED IN CONJUNCTION WITH 324000M-04	MSI	1 YR	-	6	YES	YES	-	-
	324000M-04	DI	DETAILED INSPECTION OF NLG & MLG WHEEL BEARINGS NOTE: SHOULD BE ACCOMPLISHED IN CONJUNCTION WITH 324000M-03	MSI	1 YR	-	6	YES	YES	-	-
MSI 32-60-00: POSITION & WARNING											

© Copyright 2024 Leonardo S.p.a.

This document contains information that is confidential and proprietary to Leonardo S.p.a. ('the Company') and is supplied on the express condition that it may not be disclosed to any third party, or reproduced in whole or in part, or used for manufacture, or used for any purpose other than for which it is supplied, without the prior written consent of the Company. Every permitted disclosure, reproduction, adaptation or publication of this document in whole or in part and in any manner or form shall prominently contain this notice



AW189 Maintenance Review Board Report

189G0000M006

Issue V

Page 112 of 275

REVISION STATUS	MRB-R TASK NUMBER	TASK CODE	TASK TITLE	SOURCE	INTERVAL	SAMPLING	FEC	APPLICABILITY		ZONE	ACCESS & REMARKS
								AW189	AW189ER		
	326000M-01	OC	OPERATIONAL CHECK OF THE LANDING GEAR EMERGENCY EXTENSION INDICATIONS NOTE 1: ROTORCRAFT JACKED NOTE 2: TO BE ACCOMPLISHED IN CONJUNCTION WITH 323000M-05	MSI	1 YR	-	9	YES	YES	-	-
ATA 33: LIGHTS											
MSI 33-10-00: FLIGHT / COCKPIT COMPARTMENT LIGHTING											
	331000M-01	OC	OPERATIONAL CHECK OF THE STORM LIGHTS	MSI	1 YR	-	9	YES	YES	-	-
MSI 33-42-00: SEARCHLIGHT KIT											
	334200M-01	-	TASK DELETED WITH MRBR ISSUE L	-	-	-	-	-	-	-	-
	334200M-02	-	TASK DELETED WITH MRBR ISSUE C	-	-	-	-	-	-	-	-
	334200M-03	-	TASK DELETED WITH MRBR ISSUE C	-	-	-	-	-	-	-	-

© Copyright 2024 Leonardo S.p.a.

This document contains information that is confidential and proprietary to Leonardo S.p.a. ('the Company') and is supplied on the express condition that it may not be disclosed to any third party, or reproduced in whole or in part, or used for manufacture, or used for any purpose other than for which it is supplied, without the prior written consent of the Company. Every permitted disclosure, reproduction, adaptation or publication of this document in whole or in part and in any manner or form shall prominently contain this notice



AW189 Maintenance Review Board Report

189G0000M006

Issue V

Page 113 of 275

REVISION STATUS	MRB-R TASK NUMBER	TASK CODE	TASK TITLE	SOURCE	INTERVAL	SAMPLING	FEC	APPLICABILITY		ZONE	ACCESS & REMARKS
								AW189	AW189ER		
	334200M-04	-	TASK DELETED WITH MRBR ISSUE C	-	-	-	-	-	-	-	-
	334200M-05	-	TASK DELETED WITH MRBR ISSUE C	-	-	-	-	-	-	-	-
	334200M-06	-	TASK DELETED WITH MRBR ISSUE L	-	-	-	-	-	-	-	-
	334200M-07	DI	DETAILED INSPECTION OF THE SEARCHLIGHT DRAIN HOLES	MSI	100 FH ; NOTE_B	-	9	WITH TRAKKA SEARCHLIGHT KIT	WITH TRAKKA SEARCHLIGHT KIT	-	-
	334200M-08	FC	FUNCTIONAL CHECK (BONDING CHECK) OF THE SEARCHLIGHT	MSI	1200 FH ; 1 YR	-	9	WITH TRAKKA SEARCHLIGHT KIT	WITH TRAKKA SEARCHLIGHT KIT	-	-
	334200M-09	-	TASK DELETED WITH MRBR ISSUE C	-	-	-	-	-	-	-	-
	334200M-10	DI	DETAILED INSPECTION OF THE SEARCHLIGHT SUPPORT ASSEMBLY	MSI	1600 FH	-	6; 9	WITH TRAKKA SEARCHLIGHT KIT	WITH TRAKKA SEARCHLIGHT KIT	-	-
	334200M-11	-	TASK DELETED WITH MRBR ISSUE L	-	-	-	-	-	-	-	-

© Copyright 2024 Leonardo S.p.a.

This document contains information that is confidential and proprietary to Leonardo S.p.a. ('the Company') and is supplied on the express condition that it may not be disclosed to any third party, or reproduced in whole or in part, or used for manufacture, or used for any purpose other than for which it is supplied, without the prior written consent of the Company. Every permitted disclosure, reproduction, adaptation or publication of this document in whole or in part and in any manner or form shall prominently contain this notice



AW189 Maintenance Review Board Report

189G0000M006

Issue V

Page 114 of 275

REVISION STATUS	MRB-R TASK NUMBER	TASK CODE	TASK TITLE	SOURCE	INTERVAL	SAMPLING	FEC	APPLICABILITY		ZONE	ACCESS & REMARKS
								AW189	AW189ER		
	334200M-12	DI	DETAILED INSPECTION OF TRAKKA SEARCHLIGHT ASSEMBLY	MSI	400 HR ; 1 YR	-	6; 9	WITH TRAKKA SEARCHLIGHT KIT	WITH TRAKKA SEARCHLIGHT KIT	-	-
MSI 33-50-00: EMERGENCY LIGHTING											
	335000M-01	OC	OPERATIONAL CHECK OF THE ELECTRICAL POWER SUPPLY UNIT (EPSU)	MSI	1 YR	-	8	YES	YES	-	-
	335000M-02	OC	OPERATIONAL CHECK OF EMERGENCY LIGHTS IN AUTOMATIC MODE	MSI	1 YR	-	8	YES	YES	-	-
	335000M-03	OC	OPERATIONAL CHECK OF THE HEELS SYSTEM	MSI	1 YR	-	8	WITH HEELS KIT	WITH HEELS KIT	-	-
	335000M-04	DIS	DISCARD THE HEELS BATTERY INTERVAL NOTE: 3YR OR EXPIRY DATE REPORTED ON BATTERY TAG	MSI	NOTE	-	8	WITH HEELS KIT	WITH HEELS KIT	-	-
	335000M-05	OC	OPERATIONAL CHECK OF CABIN EMERGENCY LIGHTS PUSHBUTTON	MSI	1 YR	-	8	YES	YES	-	-
	335000M-06	OC	OPERATIONAL CHECK OF EMERGENCY LIGHTS IN MANUAL MODE	MSI	1 YR	-	8	YES	YES	-	-
	335000M-07	DIS	DISCARD THE EPSU BATTERY	MSI	3 YR	-	8	YES	YES	-	-

© Copyright 2024 Leonardo S.p.a.

This document contains information that is confidential and proprietary to Leonardo S.p.a. ('the Company') and is supplied on the express condition that it may not be disclosed to any third party, or reproduced in whole or in part, or used for manufacture, or used for any purpose other than for which it is supplied, without the prior written consent of the Company. Every permitted disclosure, reproduction, adaptation or publication of this document in whole or in part and in any manner or form shall prominently contain this notice



AW189 Maintenance Review Board Report

189G0000M006

Issue V

Page 115 of 275

REVISION STATUS	MRB-R TASK NUMBER	TASK CODE	TASK TITLE	SOURCE	INTERVAL	SAMPLING	FEC	APPLICABILITY		ZONE	ACCESS & REMARKS
								AW189	AW189ER		
ATA 34: NAVIGATION											
MSI 34-10-00: FLIGHT ENVIRONMENT DATA											
	341000M-01	SV	SERVICING (DRAINING) OF THE PITOT STATIC LINES	MSI	1200 FH; NOTE_B	-	6	YES	YES	-	-
	341000M-02	GVI	GENERAL VISUAL INSPECTION OF SELECTOR VALVE FILTER	MSI	4 YR	-	9	YES	YES	-	-
	341000M-03	DI	DETAILED INSPECTION OF PITOT SUPPORT AND COVER	MSI	6 MH	-	9	YES	YES	-	-
MSI 34-21-00: ISIS											
	342100M-01	OC	OPERATIONAL CHECK OF THE EMERGENCY POWER SUPPLY	MSI	6 MH	-	9	WITH ISIS EMERGENCY POWER SUPPLY KIT	WITH ISIS EMERGENCY POWER SUPPLY KIT	-	-
	342100M-02	RST	RESTORATION (DEEP CYCLE) OF THE EMERGENCY POWER SUPPLY OFF AIRCRAFT	MSI	1 YR	-	9	WITH ISIS EMERGENCY POWER SUPPLY KIT	WITH ISIS EMERGENCY POWER SUPPLY KIT	-	-
MSI 34-22-00: AHRS											

© Copyright 2024 Leonardo S.p.a.

This document contains information that is confidential and proprietary to Leonardo S.p.a. ('the Company') and is supplied on the express condition that it may not be disclosed to any third party, or reproduced in whole or in part, or used for manufacture, or used for any purpose other than for which it is supplied, without the prior written consent of the Company. Every permitted disclosure, reproduction, adaptation or publication of this document in whole or in part and in any manner or form shall prominently contain this notice



AW189 Maintenance Review Board Report

189G0000M006

Issue V

Page 116 of 275

REVISION STATUS	MRB-R TASK NUMBER	TASK CODE	TASK TITLE	SOURCE	INTERVAL	SAMPLING	FEC	APPLICABILITY		ZONE	ACCESS & REMARKS
								AW189	AW189ER		
	342200M-01	OC	OPERATIONAL CHECK OF ATTITUDE HEADING AND REFERENCE SYSTEM (AHRS) REVERSIONARY SWITCH NOTE: COVERED BY 463000M-01	MSI	2 YR	-	9	YES	YES	-	-
ATA 46: SYSTEMS INTEGRATION AND DISPLAY											
MSI 46-20-00: PROCESSING AND INTEGRATION											
	462000M-01	OC	OPERATIONAL CHECK OF AUTOMATIC & MANUAL AIRCRAFT MANAGEMENT MISSION COMPUTER (AMMC) REVERSIONARY FUNCTIONALITY	MSI	2 YR	-	9	YES	YES	-	-
MSI 46-30-00: DISPLAY											
	463000M-01	OC	OPERATIONAL CHECK OF ATTITUDE HEADING REFERENCE SYSTEM (AHRS) / AIR DATA SYSTEM (ADS) / DISPLAY UNIT (DU) REVERSIONARY SWITCHES NOTE: COVERS 342200M-01	MSI	2 YR	-	9	YES	YES	-	-

© Copyright 2024 Leonardo S.p.a.

This document contains information that is confidential and proprietary to Leonardo S.p.a. ('the Company') and is supplied on the express condition that it may not be disclosed to any third party, or reproduced in whole or in part, or used for manufacture, or used for any purpose other than for which it is supplied, without the prior written consent of the Company. Every permitted disclosure, reproduction, adaptation or publication of this document in whole or in part and in any manner or form shall prominently contain this notice



AW189 Maintenance Review Board Report

189G0000M006

Issue V

Page 117 of 275

REVISION STATUS	MRB-R TASK NUMBER	TASK CODE	TASK TITLE	SOURCE	INTERVAL	SAMPLING	FEC	APPLICABILITY		ZONE	ACCESS & REMARKS
								AW189	AW189ER		
ATA 49: AIRBORNE AUXILIARY POWER											
MSI 49-10-00: APU MOUNTS											
	491000M-01	GVI	GENERAL VISUAL INSPECTION OF THE APU MOUNTING BEARINGS INTERVAL NOTE: CAN ALSO BE ACCOMPLISHED AT ENGINE REMOVAL	MSI	2 YR	-	9	YES	YES	-	-
	491000M-02	DI	DETAILED INSPECTION OF THE PLENUM	MSI	400 FH	-	6	YES	YES	-	-
	491000M-03	OC	OPERATIONAL CHECK OF THE PLENUM DRAIN	MSI	1600 FH	-	9	YES	YES	-	-
	491000M-04	GVI	GENERAL VISUAL INSPECTION OF THE AIR COOLED OIL COOLER DUCT	MSI	400 FH	-	6	YES	YES	-	-
	491000M-05	DI	DETAILED INSPECTION OF APU MOUNTING SPHERICAL BEARINGS INTERVAL NOTE: TO BE ACCOMPLISHED AT APU REMOVAL	MSI	NOTE	-	6	YES	YES	-	-
MSI 49-11-00: APU INLET BARRIER FILTER KIT											

© Copyright 2024 Leonardo S.p.a.

This document contains information that is confidential and proprietary to Leonardo S.p.a. ('the Company') and is supplied on the express condition that it may not be disclosed to any third party, or reproduced in whole or in part, or used for manufacture, or used for any purpose other than for which it is supplied, without the prior written consent of the Company. Every permitted disclosure, reproduction, adaptation or publication of this document in whole or in part and in any manner or form shall prominently contain this notice



AW189 Maintenance Review Board Report

189G0000M006

Issue V

Page 118 of 275

REVISION STATUS	MRB-R TASK NUMBER	TASK CODE	TASK TITLE	SOURCE	INTERVAL	SAMPLING	FEC	APPLICABILITY		ZONE	ACCESS & REMARKS
								AW189	AW189ER		
	491100M-01	DI	DETAILED INSPECTION OF APU INLET BARRIER FILTERS AND INSTALLATION	MSI	400 FH ; 1 YR	-	6 ; 9	WITH APU INLET BARRIER FILTER KIT	WITH APU INLET BARRIER FILTER KIT	-	-
	491100M-02	FC	FUNCTIONAL CHECK OF THE APU INLET BARRIER FILTER BYPASS MECHANISM	MSI	400 FH ; 1 YR	-	6 ; 9	WITH APU INLET BARRIER FILTER KIT	WITH APU INLET BARRIER FILTER KIT	-	-
MSI 49-20-00: APU-ENGINE											
	492000M-01	SDI	SPECIAL DETAILED INSPECTION (BOROSCOPE INSPECTION) OF APU ENGINE PARTS NOTE: SHOULD BE ACCOMPLISHED IN CONJUNCTION WITH 492000M-07	MSI	200 APU_H	-	5 ; 6	YES	YES	-	-

© Copyright 2024 Leonardo S.p.a.

This document contains information that is confidential and proprietary to Leonardo S.p.a. ('the Company') and is supplied on the express condition that it may not be disclosed to any third party, or reproduced in whole or in part, or used for manufacture, or used for any purpose other than for which it is supplied, without the prior written consent of the Company. Every permitted disclosure, reproduction, adaptation or publication of this document in whole or in part and in any manner or form shall prominently contain this notice



AW189 Maintenance Review Board Report

189G0000M006

Issue V

Page 119 of 275

REVISION STATUS	MRB-R TASK NUMBER	TASK CODE	TASK TITLE	SOURCE	INTERVAL	SAMPLING	FEC	APPLICABILITY		ZONE	ACCESS & REMARKS
								AW189	AW189ER		
	492000M-02	RST	RESTORATION (CHEMICAL WASH) OF THE APU INTERNAL PARTS NOTE: SHOULD BE ACCOMPLISHED IN CONJUNCTION WITH 723000M-04	MSI	150 FH	-	6	YES	YES	-	-
	492000M-03	RST	RESTORATION (WATER WASH) OF THE APU INTERNAL PARTS NOTE: SHOULD BE ACCOMPLISHED IN CONJUNCTION WITH 723000M-04	MSI	150 FH ; NOTE_B	-	6	YES	YES	-	-
	492000M-04	FC	FUNCTIONAL CHECK (POWER CHECK) OF APU	MSI	50 APU_H; 1 YR NOTE_B	-	6	YES	YES	-	-
	492000M-05	DIS	DISCARD APU TURBINE SHAFT	MSI	NOTE_A	-	5 ; 6	YES	YES	-	-
	492000M-06	DIS	DISCARD APU COMPRESSOR	MSI	NOTE_A	-	5 ; 6	YES	YES	-	-

© Copyright 2024 Leonardo S.p.a.

This document contains information that is confidential and proprietary to Leonardo S.p.a. ('the Company') and is supplied on the express condition that it may not be disclosed to any third party, or reproduced in whole or in part, or used for manufacture, or used for any purpose other than for which it is supplied, without the prior written consent of the Company. Every permitted disclosure, reproduction, adaptation or publication of this document in whole or in part and in any manner or form shall prominently contain this notice



AW189 Maintenance Review Board Report

189G0000M006

Issue V

Page 120 of 275

REVISION STATUS	MRB-R TASK NUMBER	TASK CODE	TASK TITLE	SOURCE	INTERVAL	SAMPLING	FEC	APPLICABILITY		ZONE	ACCESS & REMARKS
								AW189	AW189ER		
	492000M-07	VC	VISUAL CHECK OF APU FRONT BEARING LABYRINTH PORT NOTE: SHOULD BE ACCOMPLISHED IN CONJUNCTION WITH 492000M-01	MSI	200 APU_H	-	9	YES	YES	-	-
	492000M-08	GVI	GENERAL VISUAL INSPECTION OF APU ATTACHMENTS	MSI	400 FH	-	9	YES	YES	-	-
	492000M-09	GVI	GENERAL VISUAL INSPECTION OF APU OIL SYSTEM NOTE: COVERED BY 499000M-02	MSI	400 FH	-	6	YES	YES	-	-
MSI 49-30-00: APU FUEL AND CONTROL											
	493000M-01	DIS	DISCARD APU FUEL FILTER ELEMENT	MSI	800 APU_H	-	6 ; 9	YES	YES	-	-
	493000M-02	GVI	GENERAL VISUAL INSPECTION OF APU FUEL EQUIPMENT	MSI	400 FH	-	9	YES	YES	-	-
MSI 49-40-00: APU IGNITION/STARTING											
	494000M-01	DI	DETAILED INSPECTION OF APU ELECTRICAL STARTER MOTOR (ESM) BRUSHES	MSI	2000 APU_C	-	6	YES	YES	-	-
MSI 49-80-00: EXHAUST											

© Copyright 2024 Leonardo S.p.a.

This document contains information that is confidential and proprietary to Leonardo S.p.a. ('the Company') and is supplied on the express condition that it may not be disclosed to any third party, or reproduced in whole or in part, or used for manufacture, or used for any purpose other than for which it is supplied, without the prior written consent of the Company. Every permitted disclosure, reproduction, adaptation or publication of this document in whole or in part and in any manner or form shall prominently contain this notice



AW189 Maintenance Review Board Report

189G0000M006

Issue V

Page 121 of 275

REVISION STATUS	MRB-R TASK NUMBER	TASK CODE	TASK TITLE	SOURCE	INTERVAL	SAMPLING	FEC	APPLICABILITY		ZONE	ACCESS & REMARKS
								AW189	AW189ER		
	498000M-01	DI	DETAILED INSPECTION OF APU EXHAUST EJECTOR WELDS, MOUNTING AND SECURITY OF ATTACHMENT	MSI	800 FH	-	9	YES	YES	-	-
MSI 49-90-00: OIL											
	499000M-01	DIS	DISCARD APU OIL FILTER ELEMENT	MSI	400 APU_H	-	6 ; 9	YES	YES	-	-
	499000M-02	GVI	GENERAL VISUAL INSPECTION OF APU OIL SYSTEM NOTE: COVERS 492000M-09	MSI	400 FH	-	6	YES	YES	-	-
ATA 52: DOORS											
MSI 52-11-00: CREW											
	521100M-01	DI	DETAILED INSPECTION OF CREW DOOR LOCKING MECHANISM	MSI	3200 FH	-	6	YES	YES	-	-
MSI 52-12-00: PASSENGER (CABIN) DOORS											

© Copyright 2024 Leonardo S.p.a.

This document contains information that is confidential and proprietary to Leonardo S.p.a. ('the Company') and is supplied on the express condition that it may not be disclosed to any third party, or reproduced in whole or in part, or used for manufacture, or used for any purpose other than for which it is supplied, without the prior written consent of the Company. Every permitted disclosure, reproduction, adaptation or publication of this document in whole or in part and in any manner or form shall prominently contain this notice



AW189 Maintenance Review Board Report

189G0000M006

Issue V

Page 122 of 275

REVISION STATUS	MRB-R TASK NUMBER	TASK CODE	TASK TITLE	SOURCE	INTERVAL	SAMPLING	FEC	APPLICABILITY		ZONE	ACCESS & REMARKS
								AW189	AW189ER		
	521200M-01	DI	DETAILED INSPECTION OF DOOR HANDLE / LOCKING MECHANISM OFF AIRCRAFT NOTE: SHOULD BE ACCOMPLISHED IN CONJUNCTION WITH 521200M-02 AND 521200M-03	MSI	3200 FH ; 4 YR	-	6	WITH SLIDING DOORS	WITH SLIDING DOORS	-	-
	521200M-02	DI	DETAILED INSPECTION OF THE HINGE-TROLLEY ASSY AND DOOR RAILS NOTE: SHOULD BE ACCOMPLISHED IN CONJUNCTION WITH 521200M-03 AND 521200M-01	MSI	3200 FH ; 4 YR	-	6	WITH SLIDING DOORS	WITH SLIDING DOORS	-	-

© Copyright 2024 Leonardo S.p.a.

This document contains information that is confidential and proprietary to Leonardo S.p.a. ('the Company') and is supplied on the express condition that it may not be disclosed to any third party, or reproduced in whole or in part, or used for manufacture, or used for any purpose other than for which it is supplied, without the prior written consent of the Company. Every permitted disclosure, reproduction, adaptation or publication of this document in whole or in part and in any manner or form shall prominently contain this notice



AW189 Maintenance Review Board Report

189G0000M006

Issue V

Page 123 of 275

REVISION STATUS	MRB-R TASK NUMBER	TASK CODE	TASK TITLE	SOURCE	INTERVAL	SAMPLING	FEC	APPLICABILITY		ZONE	ACCESS & REMARKS
								AW189	AW189ER		
	521200M-03	DI	DETAILED INSPECTION OF LOCKING PIN MECHANISM NOTE: SHOULD BE ACCOMPLISHED IN CONJUNCTION WITH 521200M-01 AND 521200M-02	MSI	3200 FH ; 4 YR	-	9	WITH SLIDING DOORS	WITH SLIDING DOORS	-	-
MSI 52-12-01: HINGED PASSENGERS DOOR											
	521201M-01	DI	DETAILED INSPECTION OF CABIN DOOR HANDLE / LOCKING MECHANISM	MSI	3200 FH ; 4 YR	-	6 ; 9	WITH HINGED PASSENGERS DOOR KIT	WITH HINGED PASSENGERS DOOR KIT	-	-
MSI 52-30-00: CARGO (TASK TRANSFERRED TO ZONAL)											
	523000M-01	-	TASK DELETED WITH MRBR ISSUE C	-	-	-	-	-	-	-	-
MSI 52-40-00: SERVICE											
	524000M-01	-	TASK DELETED WITH MRBR ISSUE C	-	-	-	-	-	-	-	-
	524000M-02	-	TASK DELETED WITH MRBR ISSUE C	-	-	-	-	-	-	-	-

© Copyright 2024 Leonardo S.p.a.

This document contains information that is confidential and proprietary to Leonardo S.p.a. ('the Company') and is supplied on the express condition that it may not be disclosed to any third party, or reproduced in whole or in part, or used for manufacture, or used for any purpose other than for which it is supplied, without the prior written consent of the Company. Every permitted disclosure, reproduction, adaptation or publication of this document in whole or in part and in any manner or form shall prominently contain this notice



AW189 Maintenance Review Board Report

189G0000M006

Issue V

Page 124 of 275

REVISION STATUS	MRB-R TASK NUMBER	TASK CODE	TASK TITLE	SOURCE	INTERVAL	SAMPLING	FEC	APPLICABILITY		ZONE	ACCESS & REMARKS
								AW189	AW189ER		
	524000M-03	GVI	GENERAL VISUAL INSPECTION OF REAR SLIDING COWLING AT EJECTOR NOZZLE MOUNTINGS AND APU EJECTOR INTERFACE	MSI	200 FH	-	8	YES	YES	-	-
	524000M-04	GVI	GENERAL VISUAL INSPECTION OF ENGINE AIR INTAKE PANELS, FORWARD SLIDING COWLING, REAR SLIDING COWLING.	MSI	200 FH	-	6; 9	YES	YES	-	-
MSI 52-62-00: PASSENGER ELECTRICAL FOLDABLE FOOTSTEPS KIT											
	526200M-01	DI	DETAILED INSPECTION OF ELECTRICAL FOLDABLE FOOTSTEP MECHANISM	MSI	100 FH ; 6 MH	-	6	WITH ELECTRICAL FOLDABLE FOOTSTEP KIT	NO	-	-
MSI 52-70-00: DOOR WARNING											
	527000M-01	OC	OPERATIONAL CHECK OF DOOR MICRO-SWITCHES	MSI	3200 FH	-	9	YES	YES	-	-
MSI 52-80-00: NOSE LANDING GEAR DOORS KIT											

© Copyright 2024 Leonardo S.p.a.

This document contains information that is confidential and proprietary to Leonardo S.p.a. ('the Company') and is supplied on the express condition that it may not be disclosed to any third party, or reproduced in whole or in part, or used for manufacture, or used for any purpose other than for which it is supplied, without the prior written consent of the Company. Every permitted disclosure, reproduction, adaptation or publication of this document in whole or in part and in any manner or form shall prominently contain this notice



AW189 Maintenance Review Board Report

189G0000M006

Issue V

Page 125 of 275

REVISION STATUS	MRB-R TASK NUMBER	TASK CODE	TASK TITLE	SOURCE	INTERVAL	SAMPLING	FEC	APPLICABILITY		ZONE	ACCESS & REMARKS
								AW189	AW189ER		
	528000M-01	DI	DETAILED INSPECTION OF THE NOSE LANDING GEAR DOORS AND OPERATING MECHANISM REMARK: SHOULD BE ACCOMPLISHED IN CONJUNCTION WITH 322000M-01	MSI	800 FH	-	6 ; 9	WITH NOSE LANDING GEAR DOORS KIT	WITH NOSE LANDING GEAR DOORS KIT	-	-
ATA 55: STABILISERS											
MSI 55-10-00: STABILISER (HORIZONTAL)											
	551000M-01	OC	OPERATIONAL CHECK OF TAIL PLANE FOR ABSENCE OF PLAY	MSI	400 FH	-	9	YES	YES	-	-
ATA 56: WINDOWS AND CANOPIES											
MSI 56-10-00: FLIGHT COMPARTMENT											
	561000M-01	-	TASK DELETED WITH MRBR ISSUE B	-	-	-	-	-	-	-	-
	561000M-02	DIS	DISCARD COCKPIT DOOR EMERGENCY EXIT WINDOW SEALS AND FILLER WEDGES. INTERVAL NOTE: 4 YR; 2 YR FOR A417AF001WB / A417AG002WB	MSI	NOTE	-	8	YES	YES	-	-

© Copyright 2024 Leonardo S.p.a.

This document contains information that is confidential and proprietary to Leonardo S.p.a. ('the Company') and is supplied on the express condition that it may not be disclosed to any third party, or reproduced in whole or in part, or used for manufacture, or used for any purpose other than for which it is supplied, without the prior written consent of the Company. Every permitted disclosure, reproduction, adaptation or publication of this document in whole or in part and in any manner or form shall prominently contain this notice



AW189 Maintenance Review Board Report

189G0000M006

Issue V

Page 126 of 275

REVISION STATUS	MRB-R TASK NUMBER	TASK CODE	TASK TITLE	SOURCE	INTERVAL	SAMPLING	FEC	APPLICABILITY		ZONE	ACCESS & REMARKS
								AW189	AW189ER		
	561000M-03	GVI	GENERAL VISUAL INSPECTION OF COCKPIT DOOR WINDOW EMERGENCY RELEASE DEVICE PULL STRAPS OR TABS	MSI	2 YR	-	8	YES	YES	-	-
	561000M-04	DIS	DISCARD COCKPIT DOOR EMERGENCY EXIT WINDOW PULL TABS	MSI	4 YR	-	8	YES	YES	-	-
MSI 56-20-00: FUSELAGE COMPARTMENT											
	562000M-01	-	TASK DELETED WITH MRBR ISSUE B	-	-	-	-	-	-	-	-
	562000M-02	DIS	DISCARD ALL CABIN EMERGENCY EXIT WINDOW SEALS AND FILLER WEDGES INTERVAL NOTE: 4 YR; 2 YR FOR A417AF001WB / A417AG002WB	MSI	NOTE	-	8	YES	YES	-	-

© Copyright 2024 Leonardo S.p.a.

This document contains information that is confidential and proprietary to Leonardo S.p.a. ('the Company') and is supplied on the express condition that it may not be disclosed to any third party, or reproduced in whole or in part, or used for manufacture, or used for any purpose other than for which it is supplied, without the prior written consent of the Company. Every permitted disclosure, reproduction, adaptation or publication of this document in whole or in part and in any manner or form shall prominently contain this notice



AW189 Maintenance Review Board Report

189G0000M006

Issue V

Page 127 of 275

REVISION STATUS	MRB-R TASK NUMBER	TASK CODE	TASK TITLE	SOURCE	INTERVAL	SAMPLING	FEC	APPLICABILITY		ZONE	ACCESS & REMARKS
								AW189	AW189ER		
	562000M-03	GVI	GENERAL VISUAL INSPECTION OF ALL CABIN WINDOW EMERGENCY RELEASE DEVICE PULL STRAPS OR TABS	MSI	2 YR	-	8	YES	YES	-	-
	562000M-04	DIS	DISCARD ALL CABIN EMERGENCY EXIT WINDOW PULL TABS	MSI	4 YR	-	8	YES	YES	-	-
MSI 56-21-00: BUBBLE WINDOWS											
	562100M-01	OC	OPERATIONAL CHECK OF BUBBLE WINDOW EMERGENCY RELEASE DEVICE	MSI	2 YR	-	8	WITH BUBBLE WINDOWS KIT	WITH BUBBLE WINDOWS KIT	-	-
ATA 62: MAIN ROTOR											
MSI - RDSI 62-10-00: ROTOR BLADES											
	621000M-01	GVI	GENERAL VISUAL INSPECTION OF MAIN ROTOR BLADE	MSI ; RDSI (AD)	400 FH ; NOTE_B	-	5 ; 8 ; 9	YES	YES	410	ACCESS: EXTERNAL

© Copyright 2024 Leonardo S.p.a.

This document contains information that is confidential and proprietary to Leonardo S.p.a. ('the Company') and is supplied on the express condition that it may not be disclosed to any third party, or reproduced in whole or in part, or used for manufacture, or used for any purpose other than for which it is supplied, without the prior written consent of the Company. Every permitted disclosure, reproduction, adaptation or publication of this document in whole or in part and in any manner or form shall prominently contain this notice



AW189 Maintenance Review Board Report

189G0000M006

Issue V

Page 128 of 275

REVISION STATUS	MRB-R TASK NUMBER	TASK CODE	TASK TITLE	SOURCE	INTERVAL	SAMPLING	FEC	APPLICABILITY		ZONE	ACCESS & REMARKS
								AW189	AW189ER		
	621000M-02	SDI	SPECIAL DETAILED INSPECTION (TAP TEST) OF THE MAIN ROTOR BLADE	MSI	1600 FH	-	5 ; 9	YES	YES	-	REMOVAL: MAIN ROTOR BLADE RECOMMENDED
	621000M-03	DIS	DISCARD MAIN ROTOR BLADE	MSI	NOTE_C	-	5	YES	YES	-	-
	621000M-04	FC	FUNCTIONAL CHECK (CONTINUITY CHECK) OF MAIN ROTOR BLADE INTERVAL NOTE: SHOULD BE ACCOMPLISHED IN CONJUNCTION WITH 622000M-04	MSI	400 FH ; 1 YR	-	8	YES	YES	-	-
	621000M-05	DI	DETAILED INSPECTION OF THE MAIN ROTOR BLADE ASSY	RDSI (ED) ; CPCP	4 YR ; NOTE_B	1 YR	5 ; 8	YES	YES	410	ACCESS: EXTERNAL REMOVAL: MAIN ROTOR BLADE RECOMMENDED
	621000M-06	GVI	GENERAL VISUAL INSPECTION OF THE MAIN ROTOR BLADE BUSHES FOR FRETTING EVIDENCE	RDSI (ED) ; CPCP	3200 FH	-	5 ; 8	YES	YES	410	ACCESS: EXTERNAL REMOVAL: MAIN ROTOR BLADE RECOMMENDED

© Copyright 2024 Leonardo S.p.a.

This document contains information that is confidential and proprietary to Leonardo S.p.a. ('the Company') and is supplied on the express condition that it may not be disclosed to any third party, or reproduced in whole or in part, or used for manufacture, or used for any purpose other than for which it is supplied, without the prior written consent of the Company. Every permitted disclosure, reproduction, adaptation or publication of this document in whole or in part and in any manner or form shall prominently contain this notice



AW189 Maintenance Review Board Report

189G0000M006

Issue V

Page 129 of 275

REVISION STATUS	MRB-R TASK NUMBER	TASK CODE	TASK TITLE	SOURCE	INTERVAL	SAMPLING	FEC	APPLICABILITY		ZONE	ACCESS & REMARKS
								AW189	AW189ER		
	621000M-07	-	TASK DELETED WITH MRBR ISSUE D	-	-	-	-	-	-	-	-
MSI - RDSI 62-20-00: ROTOR HEAD(S)											
	622000M-01	GVI	GENERAL VISUAL INSPECTION OF MAIN ROTOR HEAD ASSEMBLY AND COMPONENTS	MSI	400 FH	-	5 ; 6 ; 8	YES	YES	-	-
	622000M-02	FC	FUNCTIONAL CHECK (PLAY CHECK) OF MAIN ROTOR DAMPER SPHERICAL MOUNTINGS	MSI	200 FH	-	6	YES	YES	-	-
	622000M-03	DI	DETAILED INSPECTION OF BEANIE AND ATTACHMENT INTERFACES	MSI	1600 FH	-	5	YES	YES	-	-
	622000M-04	FC	FUNCTIONAL CHECK (CONTINUITY CHECK) OF MAIN ROTOR BLADE TO MAIN ROTOR HEAD CONNECTIONS INTERVAL NOTE: SHOULD BE ACCOMPLISHED IN CONJUNCTION WITH 621000M-04	MSI	400 FH ; 1 YR	-	8	YES	YES	-	-

© Copyright 2024 Leonardo S.p.a.

This document contains information that is confidential and proprietary to Leonardo S.p.a. ('the Company') and is supplied on the express condition that it may not be disclosed to any third party, or reproduced in whole or in part, or used for manufacture, or used for any purpose other than for which it is supplied, without the prior written consent of the Company. Every permitted disclosure, reproduction, adaptation or publication of this document in whole or in part and in any manner or form shall prominently contain this notice



AW189 Maintenance Review Board Report

189G0000M006

Issue V

Page 130 of 275

REVISION STATUS	MRB-R TASK NUMBER	TASK CODE	TASK TITLE	SOURCE	INTERVAL	SAMPLING	FEC	APPLICABILITY		ZONE	ACCESS & REMARKS
								AW189	AW189ER		
	622000M-05	DI	DETAILED INSPECTION OF MAIN ROTOR BLADE BOLTS	MSI	1600 FH	-	5	YES	YES	-	REMOVAL: MAIN ROTOR BLADE BOLTS
	622000M-06	DI	DETAILED INSPECTION OF MAIN ROTOR HEAD ASSY	MSI ; RDSI (ED) ; CPCP	1600 FH ; 4 YR ; NOTE_B	1 YR	5 ; 6 ; 8 ; 9	YES	YES	410	REMOVAL: BEANIE
	622000M-07	OC	OPERATIONAL CHECK OF MAIN ROTOR FLAP LIMITERS	MSI	400 FH	-	8	YES	YES	-	-
	622000M-08	DI	DETAILED INSPECTION OF MAIN ROTOR TENSION LINK	MSI	1600 FH	-	5 ; 8	YES	YES	-	-
	622000M-09	DI	DETAILED INSPECTION OF MAIN ROTOR ELASTOMERIC SPHERICAL BEARING	MSI	400 FH	-	5 ; 6	YES	YES	-	-
	622000M-10	DIS	DISCARD MAIN ROTOR HUB ASSEMBLY	MSI	NOTE_C	-	5	YES	YES	-	-
	622000M-11	VC	VISUAL CHECK OF MAIN ROTOR LEAD LAG DAMPER OIL LEVEL	MSI	50 FH	-	9	YES	YES	-	-

© Copyright 2024 Leonardo S.p.a.

This document contains information that is confidential and proprietary to Leonardo S.p.a. ('the Company') and is supplied on the express condition that it may not be disclosed to any third party, or reproduced in whole or in part, or used for manufacture, or used for any purpose other than for which it is supplied, without the prior written consent of the Company. Every permitted disclosure, reproduction, adaptation or publication of this document in whole or in part and in any manner or form shall prominently contain this notice



AW189 Maintenance Review Board Report

189G0000M006

Issue V

Page 131 of 275

REVISION STATUS	MRB-R TASK NUMBER	TASK CODE	TASK TITLE	SOURCE	INTERVAL	SAMPLING	FEC	APPLICABILITY		ZONE	ACCESS & REMARKS
								AW189	AW189ER		
	622000M-12	RST	RESTORATION (OVERHAUL) OF MAIN ROTOR LEAD LAG DAMPER INTERVAL NOTE: 2400 FH FOR P/N 4F6220V00251 AND 8G6220V00151; 3000FH FOR P/N 8G6220V00251 OFF AIRCRAFT	MSI	NOTE	-	5 ; 6	YES	YES	-	-
	622000M-13	DI	DETAILED INSPECTION OF MAIN ROTOR HUB NOTE: SHOULD BE ACCOMPLISHED IN CONJUNCTION WITH 622000M-18	MSI	3200 FH	-	5	YES	YES	-	REMOVAL: ROTOR HUB
	622000M-14	DI	DETAILED INSPECTION OF MAIN ROTOR HEAD COMPLETE ASSEMBLY	MSI ; RDSI (ED) ; CPCP	1600 FH ; 4 YR	1 YR	5 ; 6 ; 8	YES	YES	410	ACCESS: BEANIE REMOVAL: MAIN ROTOR HUB

© Copyright 2024 Leonardo S.p.a.

This document contains information that is confidential and proprietary to Leonardo S.p.a. ('the Company') and is supplied on the express condition that it may not be disclosed to any third party, or reproduced in whole or in part, or used for manufacture, or used for any purpose other than for which it is supplied, without the prior written consent of the Company. Every permitted disclosure, reproduction, adaptation or publication of this document in whole or in part and in any manner or form shall prominently contain this notice



AW189 Maintenance Review Board Report

189G0000M006

Issue V

Page 132 of 275

REVISION STATUS	MRB-R TASK NUMBER	TASK CODE	TASK TITLE	SOURCE	INTERVAL	SAMPLING	FEC	APPLICABILITY		ZONE	ACCESS & REMARKS
								AW189	AW189ER		
	622000M-15	GVI	GENERAL VISUAL INSPECTION OF THE MAIN ROTOR PITCH ARM ASSEMBLY & BLADE BOLTS FOR FRETTING EVIDENCE	RDSI (ED) ; CPCP	1600 FH	-	5 ; 8	YES	YES	410	ACCESS: EXTERNAL
	622000M-16	DI	DETAIL INSPECTION OF THE MAIN ROTOR HUB TENSION BOLTS AGAINST THE REACTION WASHER / HUB RING NUT	RDSI (ED) ; CPCP	1600 FH	-	5 ; 8	YES	YES	410	REMOVAL: BEANIE, TENSION BOLTS, RING NUT AND SPECIAL WASHER
	622000M-17	DI	DETAILED INSPECTION OF THE MAIN ROTOR CONICAL RING UPPER	RDSI (ED) ; CPCP	2 YR ; NOTE_B	1 YR	5 ; 8	YES	YES	410	REMOVAL: BEANIE
	622000M-18	GVI	GENERAL VISUAL INSPECTION OF THE MAIN ROTOR HUB INTERFACE FOR FRETTING EVIDENCE NOTE: SHOULD BE ACCOMPLISHED IN CONJUNCTION WITH 622000M-13	RDSI (ED) ; CPCP	3200 FH	-	5 ; 8	YES	YES	410	ACCESS: BEANIE REMOVAL: MAIN ROTOR HUB

© Copyright 2024 Leonardo S.p.a.

This document contains information that is confidential and proprietary to Leonardo S.p.a. ('the Company') and is supplied on the express condition that it may not be disclosed to any third party, or reproduced in whole or in part, or used for manufacture, or used for any purpose other than for which it is supplied, without the prior written consent of the Company. Every permitted disclosure, reproduction, adaptation or publication of this document in whole or in part and in any manner or form shall prominently contain this notice



AW189 Maintenance Review Board Report

189G0000M006

Issue V

Page 133 of 275

REVISION STATUS	MRB-R TASK NUMBER	TASK CODE	TASK TITLE	SOURCE	INTERVAL	SAMPLING	FEC	APPLICABILITY		ZONE	ACCESS & REMARKS
								AW189	AW189ER		
	622000M-19	GVI	GENERAL VISUAL INSPECTION OF THE MAIN ROTOR HEAD COMPONENTS	RDSI (AD)	800 FH	-	5 ; 8	YES	YES	410	ACCESS: EXTERNAL
	622000M-20	DI	DETAILED INSPECTION OF THE MAIN ROTOR ELASTOMERIC SPHERICAL BEARING (METALLIC INTERFACES)	RDSI (ED)	4 YR ; NOTE_B	-	5 ; 8	YES	YES	410	ACCESS: EXTERNAL
	622000M-21	FC	FUNCTIONAL CHECK (TORQUE CHECK) OF THE MAIN ROTOR ELASTOMERIC BEARING OUTER MEMBER BOLTS TO THE FLAP LIMITER SUPPORT	RDSI (ED) ; CPCP	1600 FH	-	5 ; 8	YES	YES	410	ACCESS: EXTERNAL
	622000M-22	FC	FUNCTIONAL CHECK (TORQUE CHECK) OF THE MAIN ROTOR SCISSORS ATTACHMENT FLANGE SECURING BOLTS	RDSI (ED) ; CPCP	1600 FH	-	5 ; 8	YES	YES	410	ACCESS: EXTERNAL
	622000M-23	DI	DETAILED INSPECTION OF MAIN ROTOR DAMPER ANTI ROTATION BLOCKS AND BEARINGS APPLICABILITY NOTE: DAMPER P/N 8G6220V00151 AND 8G6220V00251	MSI	100 FH	-	6	NOTE	NOTE	410	ACCESS: EXTERNAL

© Copyright 2024 Leonardo S.p.a.

This document contains information that is confidential and proprietary to Leonardo S.p.a. ('the Company') and is supplied on the express condition that it may not be disclosed to any third party, or reproduced in whole or in part, or used for manufacture, or used for any purpose other than for which it is supplied, without the prior written consent of the Company. Every permitted disclosure, reproduction, adaptation or publication of this document in whole or in part and in any manner or form shall prominently contain this notice



AW189 Maintenance Review Board Report

189G0000M006

Issue V

Page 134 of 275

REVISION STATUS	MRB-R TASK NUMBER	TASK CODE	TASK TITLE	SOURCE	INTERVAL	SAMPLING	FEC	APPLICABILITY		ZONE	ACCESS & REMARKS
								AW189	AW189ER		
	622000M-24	FC	FUNCTIONAL CHECK (FRICTION MEASUREMENT) OF MAIN ROTOR DAMPER MOUNTING BEARING APPLICABILITY NOTE:DAMPER P/N 8G6220V00151 AND 8G6220V00251	MSI	100 FH	-	6	NOTE	NOTE	410	ACCESS: EXTERNAL
	622000M-25	GVI	GENERAL VISUAL INSPECTION OF ROTOR SLIDING RING OUTSIDE DIAMETER FOR PRESENCE OF GREASE	MSI	50 FH; NOTE_B	-	9	YES	YES	410	ACCESS: EXTERNAL LIFTING BLADE NOT REQUIRED
	622000M-26	DIS	DISCARD MAIN ROTOR DAMPER BODY END	MSI	NOTE_C	-	6	YES	YES	410	ACCESS: EXTERNAL
MSI - RDSI 62-30-00: ROTATING CONTROLS ROTOR SHAFT(S) / SWASH PLATE ASSEMBLIES											
	623000M-01	LU	LUBRICATION OF MAIN ROTOR SWASHPLATE ASSEMBLY DUPLEX BEARING	MSI	150 FH ; 1 YR	-	5 ; 8	YES	YES	-	-
	623000M-02	DI	DETAILED INSPECTION OF MAIN ROTOR ROTATING COMPONENTS	MSI ; RDSI (ED) ; CPCP ; RDSI (AD)	400 FH ; 2 YR ; NOTE_B	1 YR	5 ; 8 ; 9	YES	YES	410	ACCESS: EXTERNAL

© Copyright 2024 Leonardo S.p.a.

This document contains information that is confidential and proprietary to Leonardo S.p.a. ('the Company') and is supplied on the express condition that it may not be disclosed to any third party, or reproduced in whole or in part, or used for manufacture, or used for any purpose other than for which it is supplied, without the prior written consent of the Company. Every permitted disclosure, reproduction, adaptation or publication of this document in whole or in part and in any manner or form shall prominently contain this notice



AW189 Maintenance Review Board Report

189G0000M006

Issue V

Page 135 of 275

REVISION STATUS	MRB-R TASK NUMBER	TASK CODE	TASK TITLE	SOURCE	INTERVAL	SAMPLING	FEC	APPLICABILITY		ZONE	ACCESS & REMARKS
								AW189	AW189ER		
	623000M-03	DIS	DISCARD MAIN ROTOR SWASHPLATE ASSY	MSI	NOTE_C	-	5 ; 8	YES	YES	-	-
	623000M-04	FC	FUNCTIONAL CHECK (FORCE MEASUREMENT) OF MAIN ROTOR FIXED SWASHPLATE MOVEMENT NOTE: SHOULD BE ACCOMPLISHED IN CONJUNCTION WITH 623000M-05	MSI	1600 FH	-	5 ; 9	YES	YES	-	REMOVAL: SWASHPLATE ASSEMBLY
	623000M-05	DI	DETAILED INSPECTION OF MAIN ROTOR CENTERING PLATES ASSEMBLY NOTE: SHOULD BE ACCOMPLISHED IN CONJUNCTION WITH 623000M-04	MSI	1600 FH	-	9	YES	YES	-	REMOVAL: SWASHPLATE ASSEMBLY
	623000M-06	DI	DETAILED INSPECTION OF MAIN ROTOR ROTATING CONTROLS ASSEMBLY	MSI	3200 FH	-	5 ; 9	YES	YES	-	REMOVAL: MAIN ROTOR ROTATING CONTROLS ASSEMBLY

© Copyright 2024 Leonardo S.p.a.

This document contains information that is confidential and proprietary to Leonardo S.p.a. ('the Company') and is supplied on the express condition that it may not be disclosed to any third party, or reproduced in whole or in part, or used for manufacture, or used for any purpose other than for which it is supplied, without the prior written consent of the Company. Every permitted disclosure, reproduction, adaptation or publication of this document in whole or in part and in any manner or form shall prominently contain this notice



AW189 Maintenance Review Board Report

189G0000M006

Issue V

Page 136 of 275

REVISION STATUS	MRB-R TASK NUMBER	TASK CODE	TASK TITLE	SOURCE	INTERVAL	SAMPLING	FEC	APPLICABILITY		ZONE	ACCESS & REMARKS
								AW189	AW189ER		
	623000M-07	DI	DETAILED INSPECTION OF MAIN ROTOR SWASHPLATE ASSEMBLY DUPLEX BEARING	MSI	800 FH ; 1 YR	-	8	YES	YES	-	-
	623000M-08	DI	DETAILED INSPECTION OF THE MAIN ROTOR SWASHPLATE ASSEMBLY FOR FRETTING EVIDENCE NOTE: SHOULD BE ACCOMPLISHED IN CONJUNCTION WITH <u>623000M-05</u>	RDSI (ED) ; CPCP	1600 FH	-	5; 8	YES	YES	410	REMOVAL: SWASHPLATE ASSEMBLY
	623000M-09	GVI	GENERAL VISUAL INSPECTION OF THE MAIN ROTOR PITCH LINK ASSEMBLIES AND ATTACHMENT BOLTS FOR FRETTING EVIDENCE NOTE: TO BE ACCOMPLISHED BEFORE ROTOR HEAD REMOVAL	RDSI (ED) ; CPCP	1600 FH	-	5	YES	YES	410	ACCESS: EXTERNAL

© Copyright 2024 Leonardo S.p.a.

This document contains information that is confidential and proprietary to Leonardo S.p.a. ('the Company') and is supplied on the express condition that it may not be disclosed to any third party, or reproduced in whole or in part, or used for manufacture, or used for any purpose other than for which it is supplied, without the prior written consent of the Company. Every permitted disclosure, reproduction, adaptation or publication of this document in whole or in part and in any manner or form shall prominently contain this notice



AW189 Maintenance Review Board Report

189G0000M006

Issue V

Page 137 of 275

REVISION STATUS	MRB-R TASK NUMBER	TASK CODE	TASK TITLE	SOURCE	INTERVAL	SAMPLING	FEC	APPLICABILITY		ZONE	ACCESS & REMARKS
								AW189	AW189ER		
	623000M-10	DI	DETAILED INSPECTION OF THE MAIN ROTOR ROTATING SCISSORS ASSEMBLY	MSI; RDSI (ED); CPCP	1600 FH	-	5	YES	YES	410	ACCESS: EXTERNAL
	623000M-11	FC	FUNCTIONAL CHECK (PLAY CHECK) OF MR ROTATING ASSEMBLY	MSI	400 FH	-	5; 9	YES	YES	410	ACCESS: EXTERNAL
	623000M-12	DI	DETAILED INSPECTION OF MAIN ROTOR SWASHPLATE BOOT NOTE: APPLICABLE ONLY TO P/N 3G6230V00251	MSI	50 FH	-	8; 9	YES	YES	410	ACCESS: EXTERNAL
ATA 63: MAIN ROTOR DRIVE											
MSI -RDSI 63-10-00: ENGINE/GEARBOX COUPLINGS											

© Copyright 2024 Leonardo S.p.a.

This document contains information that is confidential and proprietary to Leonardo S.p.a. ('the Company') and is supplied on the express condition that it may not be disclosed to any third party, or reproduced in whole or in part, or used for manufacture, or used for any purpose other than for which it is supplied, without the prior written consent of the Company. Every permitted disclosure, reproduction, adaptation or publication of this document in whole or in part and in any manner or form shall prominently contain this notice



AW189 Maintenance Review Board Report

189G0000M006

Issue V

Page 138 of 275

REVISION STATUS	MRB-R TASK NUMBER	TASK CODE	TASK TITLE	SOURCE	INTERVAL	SAMPLING	FEC	APPLICABILITY		ZONE	ACCESS & REMARKS
								AW189	AW189ER		
	631000M-01	DI	DETAILED INSPECTION OF SHAFT GIMBAL ASSY (LH / RH) INTERVAL NOTE: TO BE ACCOMPLISHED AT ENGINE OR MAIN GEAR BOX (MGB) REMOVAL	MSI	NOTE	-	9	YES	YES	-	REMOVAL: BOLT AND FLANGE NUT
	631000M-02	DI	DETAILED INSPECTION OF THE INPUT SHAFT ASSY (LH / RH) INTERVAL NOTE: TO BE ACCOMPLISHED AT ENGINE OR MAIN GEAR BOX (MGB) REMOVAL	MSI	NOTE	-	6	YES	YES	-	REMOVAL: INPUT SHAFT
	631000M-03	RST	RESTORATION (OVERHAUL) OF MAIN GEARBOX OFF AIRCRAFT NOTE: IDENTICAL TO 632000M-01 ; COVERS 632000M-20 / 631000M-07	MSI	5200 FH	-	9	YES	YES	-	REMOVAL: MGB

© Copyright 2024 Leonardo S.p.a.

This document contains information that is confidential and proprietary to Leonardo S.p.a. ('the Company') and is supplied on the express condition that it may not be disclosed to any third party, or reproduced in whole or in part, or used for manufacture, or used for any purpose other than for which it is supplied, without the prior written consent of the Company. Every permitted disclosure, reproduction, adaptation or publication of this document in whole or in part and in any manner or form shall prominently contain this notice



AW189 Maintenance Review Board Report

189G0000M006

Issue V

Page 139 of 275

REVISION STATUS	MRB-R TASK NUMBER	TASK CODE	TASK TITLE	SOURCE	INTERVAL	SAMPLING	FEC	APPLICABILITY		ZONE	ACCESS & REMARKS
								AW189	AW189ER		
	631000M-04	GVI	GENERAL VISUAL INSPECTION OF THE SHAFT GIMBAL ASSY (LH / RH) INCLUDING FOR FRETTING EVIDENCE	MSI ; RDSI (ED) ; CPCP	800 FH	-	5 ; 8	YES	YES	471 ; 472	ACCESS: AIR INTAKE HINGED PANEL & ENGINE ACCESS PANEL
	631000M-05	LU	LUBRICATION OF INPUT SHAFT SPLINES & SEALS INTERVAL NOTE: TO BE ACCOMPLISHED AT ENGINE OR MAIN GEAR BOX (MGB) REMOVAL	MSI	NOTE	-	9	YES	YES	-	-
	631000M-06	FC	FUNCTIONAL CHECK (TORQUE CHECK) OF THE SHAFT GIMBAL ASSY TORQUE TUBE TO THE ENGINE GEARBOX CASING FASTENERS	RDSI (ED) ; CPCP	800 FH	-	5	YES	YES	471 ; 472	ACCESS: AIR INTAKE HINGED PANEL & ENGINE ACCESS PANEL

© Copyright 2024 Leonardo S.p.a.

This document contains information that is confidential and proprietary to Leonardo S.p.a. ('the Company') and is supplied on the express condition that it may not be disclosed to any third party, or reproduced in whole or in part, or used for manufacture, or used for any purpose other than for which it is supplied, without the prior written consent of the Company. Every permitted disclosure, reproduction, adaptation or publication of this document in whole or in part and in any manner or form shall prominently contain this notice



AW189 Maintenance Review Board Report

189G0000M006

Issue V

Page 140 of 275

REVISION STATUS	MRB-R TASK NUMBER	TASK CODE	TASK TITLE	SOURCE	INTERVAL	SAMPLING	FEC	APPLICABILITY		ZONE	ACCESS & REMARKS
								AW189	AW189ER		
	631000M-07	SDI	SPECIAL DETAILED INSPECTION (BOROSCOPE INSPECTION) OF MAIN GEARBOX INTERNAL COMPONENTS NOTE: IDENTICAL TO 632000M-20 ; CREDIT FOR ACCOMPLISHMENT CAN BE TAKEN FROM 632000M-01 OR 631000M-03	MSI	8 YR	-	9	YES	YES	-	REMOVAL: MR BEANIE, CLOSURE FLANGE AND INSPECTION PANELS ON GEARBOX CASE
MSI - RDSI 63-20-00: GEARBOXES											
	632000M-01	RST	RESTORATION (OVERHAUL) OF MAIN GEARBOX OFF AIRCRAFT NOTE: IDENTICAL TO 631000M-03 ; COVERS 632000M-20 / 631000M-07	MSI	5200 FH	-	5 ; 6	YES	YES	-	REMOVAL: MGB
	632000M-02	DIS	DISCARD MAIN ROTOR DRIVESHAFT	MSI	NOTE_C	-	5	YES	YES	-	-
	632000M-03	DIS	DISCARD MAIN GEARBOX CASE	MSI	NOTE_C	-	5 ; 6	YES	YES	-	-

© Copyright 2024 Leonardo S.p.a.

This document contains information that is confidential and proprietary to Leonardo S.p.a. ('the Company') and is supplied on the express condition that it may not be disclosed to any third party, or reproduced in whole or in part, or used for manufacture, or used for any purpose other than for which it is supplied, without the prior written consent of the Company. Every permitted disclosure, reproduction, adaptation or publication of this document in whole or in part and in any manner or form shall prominently contain this notice



AW189 Maintenance Review Board Report

189G0000M006

Issue V

Page 141 of 275

REVISION STATUS	MRB-R TASK NUMBER	TASK CODE	TASK TITLE	SOURCE	INTERVAL	SAMPLING	FEC	APPLICABILITY		ZONE	ACCESS & REMARKS
								AW189	AW189ER		
	632000M-04	GVI	GENERAL VISUAL INSPECTION OF MAIN GEARBOX (MGB) ASSEMBLY INCLUDING ATTACHING PARTS	MSI ; RDSI (AD)	400 FH ; 1 YR	-	5 ; 6 ; 9	YES	YES	473	ACCESS: 451A ; 471A ; 472A
	632000M-05	RST	RESTORATION (OVERHAUL) OF MAIN GEARBOX (MGB) OIL COOLER FAN OFF AIRCRAFT	MSI	5000 FH	-	6	YES	YES	-	-
	632000M-06	RST	RESTORATION (OVERHAUL) OF MAIN GEARBOX (MGB) OIL PUMP OFF AIRCRAFT	MSI	5200 FH	-	6	YES	YES	-	-
	632000M-07	DI	DETAILED INSPECTION OF MAIN GEARBOX (MGB) CASING AND OUTPUT ROTOR DRIVE SHAFT	RDSI (ED) ; CPCP	4 YR ; NOTE_B	1 YR	5	YES	YES	473	ACCESS: 451A ; 471A ; 472A
	632000M-08	GVI	GENERAL VISUAL INSPECTION OF MAIN GEARBOX CASE INTERFACES FOR FRETTING EVIDENCE	RDSI (ED) ; CPCP	3200 FH	-	5	YES	YES	473	ACCESS: 451A ; 471A ; 472A
	632000M-09	DI	DETAILED INSPECTION OF MAIN GEARBOX (MGB) TAIL ROTOR DRIVE ADAPTER FOR FRETTING EVIDENCE	RDSI (ED) ; CPCP	3200 FH	-	5	YES	YES	473	ACCESS: 451A ; 471A ; 472A

© Copyright 2024 Leonardo S.p.a.

This document contains information that is confidential and proprietary to Leonardo S.p.a. ('the Company') and is supplied on the express condition that it may not be disclosed to any third party, or reproduced in whole or in part, or used for manufacture, or used for any purpose other than for which it is supplied, without the prior written consent of the Company. Every permitted disclosure, reproduction, adaptation or publication of this document in whole or in part and in any manner or form shall prominently contain this notice



AW189 Maintenance Review Board Report

189G0000M006

Issue V

Page 142 of 275

REVISION STATUS	MRB-R TASK NUMBER	TASK CODE	TASK TITLE	SOURCE	INTERVAL	SAMPLING	FEC	APPLICABILITY		ZONE	ACCESS & REMARKS
								AW189	AW189ER		
	632000M-10	GVI	GENERAL VISUAL INSPECTION OF MAIN GEARBOX (MGB) OIL FILTER ELEMENT NOTE: TO BE ACCOMPLISHED IN CONJUNCTION WITH 632000M-11	MSI	400 FH	-	5	YES	YES	-	-
	632000M-11	SV	SERVICING (OIL REPLACEMENT) OF MAIN GEARBOX NOTE: SHOULD BE ACCOMPLISHED IN CONJUNCTION WITH 634000M-01 , 634000M-03 , 634000M-04 , 634000M-05 AND 632000M-10	MSI	400 FH ; 1 YR	-	5	YES	YES	-	-
	632000M-12	GVI	GENERAL VISUAL INSPECTION OF MAIN ROTOR DRIVESHAFT INTERVAL NOTE: TO BE ACCOMPLISHED AT ROTOR HEAD REMOVAL	MSI	NOTE	-	5	YES	YES	-	-
	632000M-13	VC	VISUAL CHECK OF THE MAIN GEARBOX (MGB) FOR PRESENCE OF OIL	MSI	50 FH	-	9	YES	YES	-	-

© Copyright 2024 Leonardo S.p.a.

This document contains information that is confidential and proprietary to Leonardo S.p.a. ('the Company') and is supplied on the express condition that it may not be disclosed to any third party, or reproduced in whole or in part, or used for manufacture, or used for any purpose other than for which it is supplied, without the prior written consent of the Company. Every permitted disclosure, reproduction, adaptation or publication of this document in whole or in part and in any manner or form shall prominently contain this notice



AW189 Maintenance Review Board Report

189G0000M006

Issue V

Page 143 of 275

REVISION STATUS	MRB-R TASK NUMBER	TASK CODE	TASK TITLE	SOURCE	INTERVAL	SAMPLING	FEC	APPLICABILITY		ZONE	ACCESS & REMARKS
								AW189	AW189ER		
	632000M-14	FC	FUNCTIONAL CHECK (TORQUE CHECK) OF THE BOLTS SECURING THE UPPER FITTINGS TO THE MAIN GEARBOX CASING	RDSI (ED) ; CPCP	800 FH	-	5	YES	YES	473	ACCESS: 451A ; 471A ; 472A
	632000M-15	DI	DETAILED INSPECTION OF MAIN ROTOR DRIVESHAFT	RDSI (ED) ; CPCP	4 YR ; NOTE_B	-	5	YES	YES	473	ACCESS: 451A ; 471A ; 472A REMOVAL: MAIN ROTOR HUB
	632000M-16	DI	DETAILED INSPECTION OF MAIN ROTOR MAST TO MAIN ROTOR HUB INTERFACE FOR FRETTING EVIDENCE NOTE: SHOULD BE ACCOMPLISHED IN CONJUNCTION WITH ROTOR HEAD REMOVAL	RDSI (ED) ; CPCP	3200 FH	-	5	YES	YES	473	ACCESS: 451A ; 471A ; 472A
	632000M-17	FC	FUNCTIONAL CHECK (TORQUE CHECK) OF THE FASTENERS SECURING THE MGB TAIL ROTOR ADAPTOR TO FLEXIBLE COUPLING	RDSI (ED) ; CPCP	800 FH	-	5	YES	YES	473	ACCESS: 451A ; 471A ; 472A
	632000M-18	RST	RESTORATION (OVERHAUL) OF MGB OIL COOLER ASSY OFF AIRCRAFT	MSI	10000 FH	-	6	YES	YES	-	-

© Copyright 2024 Leonardo S.p.a.

This document contains information that is confidential and proprietary to Leonardo S.p.a. ('the Company') and is supplied on the express condition that it may not be disclosed to any third party, or reproduced in whole or in part, or used for manufacture, or used for any purpose other than for which it is supplied, without the prior written consent of the Company. Every permitted disclosure, reproduction, adaptation or publication of this document in whole or in part and in any manner or form shall prominently contain this notice



AW189 Maintenance Review Board Report

189G0000M006

Issue V

Page 144 of 275

REVISION STATUS	MRB-R TASK NUMBER	TASK CODE	TASK TITLE	SOURCE	INTERVAL	SAMPLING	FEC	APPLICABILITY		ZONE	ACCESS & REMARKS
								AW189	AW189ER		
	632000M-19	VC	VISUAL CHECK OF MGB EMERGENCY RESERVOIRS FOR ABSENCE OF OIL NOTE: SHOULD BE ACCOMPLISHED IN CONJUNCTION WITH 632000M-11	MSI	400 FH	-	9	YES	YES	-	-
	632000M-20	SDI	SPECIAL DETAILED INSPECTION (BOROSCOPE INSPECTION) OF MAIN GEARBOX INTERNAL COMPONENTS NOTE: IDENTICAL TO 631000M-07 ; CREDIT FOR ACCOMPLISHMENT CAN BE TAKEN FROM 632000M-01 OR 631000M-03	MSI	8 YR	-	9	YES	YES	-	REMOVAL: MR BEANIE, CLOSURE FLANGE AND INSPECTION PANELS ON GEARBOX CASE
MSI 63-30-00: MOUNTS, ATTACHMENTS											

© Copyright 2024 Leonardo S.p.a.

This document contains information that is confidential and proprietary to Leonardo S.p.a. ('the Company') and is supplied on the express condition that it may not be disclosed to any third party, or reproduced in whole or in part, or used for manufacture, or used for any purpose other than for which it is supplied, without the prior written consent of the Company. Every permitted disclosure, reproduction, adaptation or publication of this document in whole or in part and in any manner or form shall prominently contain this notice



AW189 Maintenance Review Board Report

189G0000M006

Issue V

Page 145 of 275

REVISION STATUS	MRB-R TASK NUMBER	TASK CODE	TASK TITLE	SOURCE	INTERVAL	SAMPLING	FEC	APPLICABILITY		ZONE	ACCESS & REMARKS
								AW189	AW189ER		
	633000M-01	DI	DETAILED INSPECTION OF MAIN GEARBOX (MGB) ROD END BUSHES NOTE: SHOULD BE ACCOMPLISHED IN CONJUNCTION WITH 633000M-03 AND 633000M-04	MSI	5200 FH	-	9	YES	YES	-	-
	633000M-02	GVI	GENERAL VISUAL INSPECTION OF THE MAIN GEAR BOX (MGB) MOUNTING INSTALLATION	MSI	800 FH	-	9	YES	YES	-	-
	633000M-03	FC	FUNCTIONAL CHECK (PLAY CHECK) OF THE MAIN GEAR BOX (MGB) BRACKET & MGB BRACKET ASSEMBLY SPHERICAL BEARINGS NOTE: SHOULD BE ACCOMPLISHED IN CONJUNCTION WITH 633000M-01 AND 633000M-04	MSI	5200 FH	-	9	YES	YES	-	-

© Copyright 2024 Leonardo S.p.a.

This document contains information that is confidential and proprietary to Leonardo S.p.a. ('the Company') and is supplied on the express condition that it may not be disclosed to any third party, or reproduced in whole or in part, or used for manufacture, or used for any purpose other than for which it is supplied, without the prior written consent of the Company. Every permitted disclosure, reproduction, adaptation or publication of this document in whole or in part and in any manner or form shall prominently contain this notice



AW189 Maintenance Review Board Report

189G0000M006

Issue V

Page 146 of 275

REVISION STATUS	MRB-R TASK NUMBER	TASK CODE	TASK TITLE	SOURCE	INTERVAL	SAMPLING	FEC	APPLICABILITY		ZONE	ACCESS & REMARKS
								AW189	AW189ER		
	633000M-04	OC	OPERATIONAL CHECK OF THE MAIN GEAR BOX (MGB) BRACKET & MGB BRACKET ASSEMBLY SPHERICAL BEARING MOVEMENT NOTE: SHOULD BE ACCOMPLISHED IN CONJUNCTION WITH 633000M-01 AND 633000M-03	MSI	5200 FH	-	9	YES	YES	-	-
MSI 63-40-00: INDICATING											
	634000M-01	OC	OPERATIONAL CHECK OF MAIN GEARBOX LOW OIL LEVEL INDICATION NOTE: TO BE ACCOMPLISHED IN CONJUNCTION WITH 632000M-11	MSI	400 FH ; 1 YR	-	9	YES	YES	-	-
	634000M-02	OC	OPERATIONAL CHECK OF MAIN GEARBOX (MGB) CHIP DETECTOR AND FUZZ BURNER SYSTEM	MSI	1600 FH ; 4 YR	-	8 ; 9	YES	YES	-	-

© Copyright 2024 Leonardo S.p.a.

This document contains information that is confidential and proprietary to Leonardo S.p.a. ('the Company') and is supplied on the express condition that it may not be disclosed to any third party, or reproduced in whole or in part, or used for manufacture, or used for any purpose other than for which it is supplied, without the prior written consent of the Company. Every permitted disclosure, reproduction, adaptation or publication of this document in whole or in part and in any manner or form shall prominently contain this notice



AW189 Maintenance Review Board Report

189G0000M006

Issue V

Page 147 of 275

REVISION STATUS	MRB-R TASK NUMBER	TASK CODE	TASK TITLE	SOURCE	INTERVAL	SAMPLING	FEC	APPLICABILITY		ZONE	ACCESS & REMARKS
								AW189	AW189ER		
	634000M-03	DI	DETAILED INSPECTION OF MAIN GEARBOX (MGB) MAGNETIC CHIP DETECTORS NOTE: SHOULD BE ACCOMPLISHED IN CONJUNCTION WITH 632000M-11	MSI	400 FH ; 1 YR	-	8	YES	YES	-	-
	634000M-04	GVI	GENERAL VISUAL INSPECTION OF MAIN GEARBOX OIL LEVEL SIGHT GLASS NOTE: TO BE ACCOMPLISHED IN CONJUNCTION WITH 632000M-11	MSI	400 FH ; 1 YR	-	9	YES	YES	-	-
	634000M-05	-	TASK DELETED WITH MRBR ISSUE C	-	-	-	-	-	-	-	-
MSI 63-51-00: ROTOR BRAKE ASSEMBLY KIT											
	635100M-01	DI	DETAILED INSPECTION OF ROTOR BRAKE PUCKS WEAR INDICATORS	MSI	400 FH	-	6	WITH ROTOR BRAKE KIT	WITH ROTOR BRAKE KIT	-	-

© Copyright 2024 Leonardo S.p.a.

This document contains information that is confidential and proprietary to Leonardo S.p.a. ('the Company') and is supplied on the express condition that it may not be disclosed to any third party, or reproduced in whole or in part, or used for manufacture, or used for any purpose other than for which it is supplied, without the prior written consent of the Company. Every permitted disclosure, reproduction, adaptation or publication of this document in whole or in part and in any manner or form shall prominently contain this notice



AW189 Maintenance Review Board Report

189G0000M006

Issue V

Page 148 of 275

REVISION STATUS	MRB-R TASK NUMBER	TASK CODE	TASK TITLE	SOURCE	INTERVAL	SAMPLING	FEC	APPLICABILITY		ZONE	ACCESS & REMARKS
								AW189	AW189ER		
	635100M-02	DIS	DISCARD ROTOR BRAKE DISC INTERVAL NOTE: REPLACE ROTOR BRAKE DISC EVERY TWO PUCK REPLACEMENTS	MSI	NOTE	-	6	WITH ROTOR BRAKE KIT	WITH ROTOR BRAKE KIT	-	-
	635100M-03	DI	DETAILED INSPECTION OF ROTOR BRAKE DISC COVER	MSI	1600 FH	-	8	WITH ROTOR BRAKE KIT	WITH ROTOR BRAKE KIT	-	-
	635100M-04	GVI	GENERAL VISUAL INSPECTION OF ROTOR BRAKE COMPONENTS NOTE: IDENTICAL TO 635200M-01	MSI	400 FH	-	9	WITH ROTOR BRAKE KIT	WITH ROTOR BRAKE KIT	-	-
MSI 63-52-00: ROTOR BRAKE ACTUATION SYSTEM KIT											
	635200M-01	GVI	GENERAL VISUAL INSPECTION OF ROTOR BRAKE COMPONENTS NOTE: IDENTICAL TO 635100M-04	MSI	400 FH	-	6 ; 9	WITH ROTOR BRAKE KIT	WITH ROTOR BRAKE KIT	-	-

© Copyright 2024 Leonardo S.p.a.

This document contains information that is confidential and proprietary to Leonardo S.p.a. ('the Company') and is supplied on the express condition that it may not be disclosed to any third party, or reproduced in whole or in part, or used for manufacture, or used for any purpose other than for which it is supplied, without the prior written consent of the Company. Every permitted disclosure, reproduction, adaptation or publication of this document in whole or in part and in any manner or form shall prominently contain this notice



AW189 Maintenance Review Board Report

189G0000M006

Issue V

Page 149 of 275

REVISION STATUS	MRB-R TASK NUMBER	TASK CODE	TASK TITLE	SOURCE	INTERVAL	SAMPLING	FEC	APPLICABILITY		ZONE	ACCESS & REMARKS
								AW189	AW189ER		
	635200M-02	RST	RESTORATION (OVERHAUL) OF ROTOR BRAKE ACTUATOR ASSEMBLY OFF AIRCRAFT	MSI	33000 RL	-	6	WITH ROTOR BRAKE KIT	WITH ROTOR BRAKE KIT	-	-
MSI 63-70-00: MAIN GEARBOX OIL DRAINS											
	637000M-01	-	TASK DELETED WITH MRBR ISSUE B	-	-	-	-	-	-	-	-
ATA 64: TAIL ROTOR											
MSI - RDSI 64-10-00: ROTOR BLADES											
	641000M-01	GVI	GENERAL VISUAL INSPECTION OF THE TAIL ROTOR BLADE	MSI ; RDSI (AD)	400 FH ; NOTE_B	-	5 ; 8 ; 9	YES	YES	440	ACCESS: EXTERNAL
	641000M-02	SDI	SPECIAL DETAILED INSPECTION (TAP TEST) OF THE TAIL ROTOR BLADE	MSI	1600 FH	-	5 ; 6 ; 9	YES	YES	-	REMOVAL: TAIL ROTOR BLADE RECOMMENDED
	641000M-03	DIS	DISCARD TAIL ROTOR BLADE	MSI	NOTE_C	-	5	YES	YES	-	-
	641000M-04	FC	FUNCTIONAL CHECK (CONTINUITY CHECK) OF TAIL ROTOR BLADE	MSI	400 FH ; 1 YR	-	8	YES	YES	-	-
	641000M-05	DI	DETAILED INSPECTION OF THE TAIL ROTOR BLADE BOLT	MSI	1600 FH	-	5	YES	YES	-	REMOVAL: TAIL ROTOR BLADE BOLT AND BLADE

© Copyright 2024 Leonardo S.p.a.

This document contains information that is confidential and proprietary to Leonardo S.p.a. ('the Company') and is supplied on the express condition that it may not be disclosed to any third party, or reproduced in whole or in part, or used for manufacture, or used for any purpose other than for which it is supplied, without the prior written consent of the Company. Every permitted disclosure, reproduction, adaptation or publication of this document in whole or in part and in any manner or form shall prominently contain this notice



AW189 Maintenance Review Board Report

189G0000M006

Issue V

Page 150 of 275

REVISION STATUS	MRB-R TASK NUMBER	TASK CODE	TASK TITLE	SOURCE	INTERVAL	SAMPLING	FEC	APPLICABILITY		ZONE	ACCESS & REMARKS
								AW189	AW189ER		
	641000M-06	DI	DETAILED INSPECTION OF THE TAIL ROTOR ELASTOMERIC BEARING	MSI	400 FH	-	5	YES	YES	-	-
	641000M-07	DI	DETAILED INSPECTION OF THE TAIL ROTOR BLADE ASSY	RDSI (ED) ; CPCP	4 YR ; NOTE_B	1 YR	5 ; 8	YES	YES	440	REMOVAL: TAIL ROTOR BLADE
	641000M-08	GVI	GENERAL VISUAL INSPECTION OF THE TAIL ROTOR ELASTOMERIC BEARING ASSY & PITCH CONTROL ARM	RDSI (AD)	400 FH	-	5 ; 8	YES	YES	440	ACCESS: EXTERNAL
	641000M-09	GVI	GENERAL VISUAL INSPECTION OF THE TAIL ROTOR ATTACHING COMPONENTS FOR FRETTING EVIDENCE	RDSI (ED) ; CPCP	1600 FH	-	5 ; 8	YES	YES	440	ACCESS: EXTERNAL
	641000M-10	FC	FUNCTIONAL CHECK (TORQUE CHECK) OF THE FASTENERS SECURING TAIL ROTOR ELASTOMERIC BEARING ASSY – OUTER MEMBER TO THE BLADE HANDLE / PITCH CONTROL ARM	RDSI (ED) ; CPCP	1600 FH	-	5 ; 8	YES	YES	440	ACCESS: EXTERNAL REMOVAL: TAIL ROTOR BLADE RECOMMENDED

© Copyright 2024 Leonardo S.p.a.

This document contains information that is confidential and proprietary to Leonardo S.p.a. ('the Company') and is supplied on the express condition that it may not be disclosed to any third party, or reproduced in whole or in part, or used for manufacture, or used for any purpose other than for which it is supplied, without the prior written consent of the Company. Every permitted disclosure, reproduction, adaptation or publication of this document in whole or in part and in any manner or form shall prominently contain this notice



AW189 Maintenance Review Board Report

189G0000M006

Issue V

Page 151 of 275

REVISION STATUS	MRB-R TASK NUMBER	TASK CODE	TASK TITLE	SOURCE	INTERVAL	SAMPLING	FEC	APPLICABILITY		ZONE	ACCESS & REMARKS
								AW189	AW189ER		
	641000M-11	-	TASK DELETED WITH MRBR ISSUE D	-	-	-	-	-	-	-	-
MSI - RDSI 64-20-00: ROTOR HEAD											
	642000M-01	GVI	GENERAL VISUAL INSPECTION OF TAIL ROTOR HEAD	MSI ; RDSI (AD)	400 FH	-	5 ; 6 ; 9	YES	YES	430	ACCESS: EXTERNAL
	642000M-02	DI	DETAILED INSPECTION OF TAIL ROTOR LAG DAMPER ELASTOMERIC BEARINGS	MSI	400 FH	-	6	YES	YES	-	-
	642000M-03	DI	DETAILED INSPECTION OF TAIL ROTOR HEAD ASSEMBLY	MSI ; RDSI (ED) ; CPCP	1600 FH ; 4 YR ; NOTE_B	1 YR	5 ; 6	YES	YES	430	ACCESS: EXTERNAL REMOVAL: TAIL ROTOR HEAD
	642000M-04	DI	DETAILED INSPECTION OF TAIL ROTOR HUB	MSI	3200 FH	-	5	YES	YES	-	-
	642000M-05	DIS	DISCARD TAIL ROTOR HUB ASSEMBLY	MSI	NOTE_C	-	5	YES	YES	-	-

© Copyright 2024 Leonardo S.p.a.

This document contains information that is confidential and proprietary to Leonardo S.p.a. ('the Company') and is supplied on the express condition that it may not be disclosed to any third party, or reproduced in whole or in part, or used for manufacture, or used for any purpose other than for which it is supplied, without the prior written consent of the Company. Every permitted disclosure, reproduction, adaptation or publication of this document in whole or in part and in any manner or form shall prominently contain this notice



AW189 Maintenance Review Board Report

189G0000M006

Issue V

Page 152 of 275

REVISION STATUS	MRB-R TASK NUMBER	TASK CODE	TASK TITLE	SOURCE	INTERVAL	SAMPLING	FEC	APPLICABILITY		ZONE	ACCESS & REMARKS
								AW189	AW189ER		
	642000M-06	DIS	DISCARD TAIL ROTOR LEAD LAG DAMPER	MSI	NOTE_C	-	5 ; 6	YES	YES	-	-
	642000M-07	GVI	GENERAL VISUAL INSPECTION OF THE TAIL ROTOR HUB INTERFACE FOR FRETTING EVIDENCE	RDSI (ED) ; CPCP	3200 FH	-	5	YES	YES	430	ACCESS: EXTERNAL REMOVAL: TAIL ROTOR HUB
	642000M-08	DI	DETAILED INSPECTION OF THE TAIL ROTOR HUB LOCKNUT & CONICAL RING BOLTS	RDSI (ED) ; CPCP	2 YR ; NOTE_B	1 YR	5	YES	YES	430	ACCESS: EXTERNAL
	642000M-09	FC	FUNCTIONAL CHECK (TORQUE CHECK) OF THE TAIL ROTOR HUB CONICAL RING BOLTS NOTE: TO BE ACCOMPLISHED BEFORE TAIL ROTOR HEAD REMOVAL	RDSI (ED) ; CPCP	1600 FH	-	5	YES	YES	430	ACCESS: EXTERNAL
	642000M-10	DI	DETAILED INSPECTION OF THE TAIL ROTOR HUB SCISSOR INTERFACE NOTE: SHOULD BE ACCOMPLISHED IN CONJUNCTION WITH TASK 643000M-05	RDSI (ED) ; CPCP	800 FH	-	5	YES	YES	430	ACCESS: EXTERNAL

© Copyright 2024 Leonardo S.p.a.

This document contains information that is confidential and proprietary to Leonardo S.p.a. ('the Company') and is supplied on the express condition that it may not be disclosed to any third party, or reproduced in whole or in part, or used for manufacture, or used for any purpose other than for which it is supplied, without the prior written consent of the Company. Every permitted disclosure, reproduction, adaptation or publication of this document in whole or in part and in any manner or form shall prominently contain this notice



AW189 Maintenance Review Board Report

189G0000M006

Issue V

Page 153 of 275

REVISION STATUS	MRB-R TASK NUMBER	TASK CODE	TASK TITLE	SOURCE	INTERVAL	SAMPLING	FEC	APPLICABILITY		ZONE	ACCESS & REMARKS
								AW189	AW189ER		
	642000M-11	FC	FUNCTIONAL CHECK (TRACK & BALANCE CHECK) OF THE TAIL ROTOR VIBRATION LEVELS NOTE: IDENTICAL TO 643000M-08	MSI	800 FH	-	6	WITHOUT HUMS KIT	WITHOUT HUMS KIT	-	-
	642000M-12	FC	FUNCTIONAL CHECK (HUMS DATA READ OUT) OF THE TAIL ROTOR VIBRATION LEVELS NOTE: IDENTICAL TO 643000M-09	MSI	800 FH	-	6	WITH HUMS KIT	WITH HUMS KIT	-	-
	642000M-13	VC	VISUAL CHECK OF TAIL ROTOR LEAD LAG DAMPER FLUID LEVEL	MSI	50 FH	-	9	YES	YES	-	-
MSI - RDSI 64-30-00: ROTATING CONTROL											
	643000M-01	GVI	GENERAL VISUAL INSPECTION OF TAIL ROTOR ROTATING CONTROLS	MSI ; RDSI (AD)	400 FH	-	5 ; 6 ; 9	YES	YES	430	ACCESS: EXTERNAL
	643000M-02	DI	DETAILED INSPECTION OF TAIL ROTOR HUB SPIDER, SLIDER & DUPLEX BEARING INSTALLATION	MSI ; RDSI (ED) ; CPCP	100 FH	-	5 ; 6	YES	YES	430	ACCESS: EXTERNAL REMOVAL: SLIDING CONTROL ASSEMBLY (SPIDER AND SLIDER)

© Copyright 2024 Leonardo S.p.a.

This document contains information that is confidential and proprietary to Leonardo S.p.a. ('the Company') and is supplied on the express condition that it may not be disclosed to any third party, or reproduced in whole or in part, or used for manufacture, or used for any purpose other than for which it is supplied, without the prior written consent of the Company. Every permitted disclosure, reproduction, adaptation or publication of this document in whole or in part and in any manner or form shall prominently contain this notice



AW189 Maintenance Review Board Report

189G0000M006

Issue V

Page 154 of 275

REVISION STATUS	MRB-R TASK NUMBER	TASK CODE	TASK TITLE	SOURCE	INTERVAL	SAMPLING	FEC	APPLICABILITY		ZONE	ACCESS & REMARKS
								AW189	AW189ER		
	643000M-03	DI	DETAILED INSPECTION OF TAIL ROTOR ROTATING CONTROL COMPONENTS	MSI ; RDSI (ED) ; CPCP	1600 FH ; 4 YR ; NOTE_B	1 YR	5 ; 6	YES	YES	430	ACCESS: EXTERNAL REMOVAL: SPIDER PLUG
	643000M-04	FC	FUNCTIONAL CHECK (TORQUE CHECK) OF THE BOLTED JOIN BETWEEN THE TAIL ROTOR SPIDER AND THE SLIDER	RDSI (ED) ; CPCP	1600 FH	-	5	YES	YES	430	ACCESS: EXTERNAL
	643000M-05	DI	DETAILED INSPECTION OF THE TAIL ROTOR SCISSORS LINK BUSHES AND SLEEVES NOTE: SHOULD BE ACCOMPLISHED IN CONJUNCTION WITH TASK 642000M-10	MSI; RDSI (ED) ; CPCP	800 FH	-	5	YES	YES	430	ACCESS: EXTERNAL
	643000M-06	-	TASK DELETED WITH MRBR ISSUE U	-	-	-	-	-	-	-	-

© Copyright 2024 Leonardo S.p.a.

This document contains information that is confidential and proprietary to Leonardo S.p.a. ('the Company') and is supplied on the express condition that it may not be disclosed to any third party, or reproduced in whole or in part, or used for manufacture, or used for any purpose other than for which it is supplied, without the prior written consent of the Company. Every permitted disclosure, reproduction, adaptation or publication of this document in whole or in part and in any manner or form shall prominently contain this notice



AW189 Maintenance Review Board Report

189G0000M006

Issue V

Page 155 of 275

REVISION STATUS	MRB-R TASK NUMBER	TASK CODE	TASK TITLE	SOURCE	INTERVAL	SAMPLING	FEC	APPLICABILITY		ZONE	ACCESS & REMARKS
								AW189	AW189ER		
	643000M-07	-	TASK DELETED WITH MRBR ISSUE U	-	-	-	-	-	-	-	-
	643000M-08	FC	FUNCTIONAL CHECK (TRACK & BALANCE CHECK) OF THE TAIL ROTOR VIBRATION LEVELS NOTE: IDENTICAL TO 642000M-11	MSI	800 FH	-	9	WITHOUT HUMS KIT	WITHOUT HUMS KIT	-	-
	643000M-09	FC	FUNCTIONAL CHECK (HUMS DATA READ OUT) OF THE TAIL ROTOR VIBRATION LEVELS NOTE: IDENTICAL TO 642000M-12	MSI	800 FH	-	9	WITH HUMS KIT	WITH HUMS KIT	-	-
	643000M-10	FC	FUNCTIONAL CHECK (ROTATIONAL PLAY) OF TAIL ROTOR SCISSOR ASSEMBLY	MSI	400 FH	-	9	YES	YES	-	-
	643000M-11	DI	DETAILED INSPECTION OF THE TAIL ROTOR SPIDER / SLIDER INTERFACE AND DUPLEX BEARING	RDSI (ED) ; CPCP	4 YR ; NOTE_B	1 YR	5	YES	YES	430	ACCESS: EXTERNAL REMOVAL: SPIDER ASSEMBLY AND BEARING FLANGE

© Copyright 2024 Leonardo S.p.a.

This document contains information that is confidential and proprietary to Leonardo S.p.a. ('the Company') and is supplied on the express condition that it may not be disclosed to any third party, or reproduced in whole or in part, or used for manufacture, or used for any purpose other than for which it is supplied, without the prior written consent of the Company. Every permitted disclosure, reproduction, adaptation or publication of this document in whole or in part and in any manner or form shall prominently contain this notice



AW189 Maintenance Review Board Report

189G0000M006

Issue V

Page 156 of 275

REVISION STATUS	MRB-R TASK NUMBER	TASK CODE	TASK TITLE	SOURCE	INTERVAL	SAMPLING	FEC	APPLICABILITY		ZONE	ACCESS & REMARKS
								AW189	AW189ER		
	643000M-12	DI	DETAILED INSPECTION OF THE TAIL ROTOR PITCH LINK ASSEMBLIES ELASTOMERIC BEARING	MSI	400 FH	-	6 ; 9	YES	YES	-	-
	643000M-13	DIS	DISCARD TAIL ROTOR DUPLEX BEARING	MSI	400 FH	-	5	YES	YES	430	ACCESS: EXTERNAL REMOVAL: SLIDING CONTROL ASSEMBLY (SPIDER AND SLIDER)
	643000M-14	FC	FUNCTIONAL CHECK (PLAY MEASUREMENT) FOR SLIDING BUSH WEAR	MSI	400 FH	-	9	YES	YES	-	-
	643000M-15	VC	VISUAL CHECK OF THE TAIL ROTOR DUPLEX BEARING THERMAL STRIP	MSI	50 FH	-	8	YES	YES	430	EXTERNAL: SPIDER PLUG REMOVED
	643000M-16	DI	DETAILED INSPECTION OF TAIL ROTOR DUPLEX BEARING	MSI	50 FH	-	5	YES	YES	430	EXTERNAL: SPIDER PLUG REMOVED
ATA 65: TAIL ROTOR DRIVE											
MSI - RDSI 65-10-00: SHAFTS											
	651000M-01	GVI	GENERAL VISUAL INSPECTION OF THE TAIL ROTOR DRIVE SYSTEM COMPONENTS	MSI ; RDSI (AD)	400 FH	-	5 ; 6 ; 8 ; 9	YES	YES	491 ; 492 ; 493	ACCESS: 461A ; 463A ; 481A ; 491A ; 492A ; 493A ; 495A
	651000M-02	DI	DETAILED INSPECTION OF TAIL ROTOR DRIVE COMPONENTS	MSI	800 FH	-	5 ; 8	YES	YES	-	-

© Copyright 2024 Leonardo S.p.a.

This document contains information that is confidential and proprietary to Leonardo S.p.a. ('the Company') and is supplied on the express condition that it may not be disclosed to any third party, or reproduced in whole or in part, or used for manufacture, or used for any purpose other than for which it is supplied, without the prior written consent of the Company. Every permitted disclosure, reproduction, adaptation or publication of this document in whole or in part and in any manner or form shall prominently contain this notice



AW189 Maintenance Review Board Report

189G0000M006

Issue V

Page 157 of 275

REVISION STATUS	MRB-R TASK NUMBER	TASK CODE	TASK TITLE	SOURCE	INTERVAL	SAMPLING	FEC	APPLICABILITY		ZONE	ACCESS & REMARKS
								AW189	AW189ER		
	651000M-03	LU	LUBRICATION OF DRIVE SHAFT BEARING HOUSING (NO'S 1 & 2)	MSI	1600 FH	-	5 ; 6	YES	YES	-	-
	651000M-04	DI	DETAILED INSPECTION OF DRIVE SHAFT BEARING HOUSINGS (NO'S 1 & 2) OFF AIRCRAFT	MSI	1600 FH	-	8	YES	YES	-	REMOVAL: BEARING HOUSING ASSEMBLIES (EXCLUDING MOUNTING BRACKETS)
	651000M-05	DI	DETAILED INSPECTION OF TAIL ROTOR DRIVE SHAFT (TRDS) CONNECTING BOLTS, DAMPER AND BEARING HOUSING ASSEMBLIES	RDSI (ED) ; CPCP	4 YR ; NOTE_B	1 YR	5 ; 8	YES	YES	491 ; 492 ; 493	ACCESS: 461A ; 463A ; 481A ; 491A ; 492A ; 493A ; 495A
	651000M-06	FC	FUNCTIONAL CHECK (TORQUE CHECK) OF THE FASTENERS SECURING THE SIX FLEXIBLE COUPLING INTERFACES	RDSI (ED) ; CPCP	800 FH	-	5 ; 8	YES	YES	491 ; 492 ; 493	ACCESS: 461A ; 463A ; 481A ; 491A ; 492A ; 493A ; 495A
	651000M-07	FC	FUNCTIONAL CHECK (TORQUE CHECK) OF THE FASTENERS SECURING THE TAIL ROTOR DRIVE SHAFT BEARING HOUSING COUPLING INTERFACE	RDSI (ED) ; CPCP	800 FH	-	5 ; 8	YES	YES	491 ; 492	ACCESS: 481A ; 491A ; 492A

© Copyright 2024 Leonardo S.p.a.

This document contains information that is confidential and proprietary to Leonardo S.p.a. ('the Company') and is supplied on the express condition that it may not be disclosed to any third party, or reproduced in whole or in part, or used for manufacture, or used for any purpose other than for which it is supplied, without the prior written consent of the Company. Every permitted disclosure, reproduction, adaptation or publication of this document in whole or in part and in any manner or form shall prominently contain this notice



AW189 Maintenance Review Board Report

189G0000M006

Issue V

Page 158 of 275

REVISION STATUS	MRB-R TASK NUMBER	TASK CODE	TASK TITLE	SOURCE	INTERVAL	SAMPLING	FEC	APPLICABILITY		ZONE	ACCESS & REMARKS
								AW189	AW189ER		
	651000M-08	DI	DETAILED INSPECTION OF THE NO'S 1 & 2 TAIL ROTOR DRIVE SHAFT (TRDS) BEARING HOUSING SPLINED COUPLING INTERFACES FOR FRETTING EVIDENCE	RDSI (ED) ; CPCP	5200 FH	-	5 ; 8	YES	YES	491 ; 492	ACCESS: 481A ; 491A ; 492A REMOVAL: BEARING SUPPORT HOUSING 1 & 2
	651000M-09	FC	FUNCTIONAL CHECK (TORQUE CHECK) OF THE FASTENERS SECURING THE MAIN BEARING INTO THE TAIL ROTOR DRIVE SHAFT (TRDS) BEARING HOUSING (NO'S 1 & 2)	RDSI (ED) ; CPCP	800 FH	-	5 ; 8	YES	YES	491 ; 492	ACCESS: 481A ; 491A ; 492A
	651000M-10	GVI	GENERAL VISUAL INSPECTION OF NO'S 1 & 2 TAIL ROTOR DRIVE SHAFT (TRDS) BEARING HOUSING SPHERICAL BEARINGS INTERFACES FOR FRETTING EVIDENCE NOTE: TO BE ACCOMPLISHED BEFORE TRDS BEARING HOUSING REMOVAL	RDSI (ED) ; CPCP	3200 FH	-	5 ; 8	YES	YES	491 ; 492	ACCESS: 481A ; 491A ; 492A

© Copyright 2024 Leonardo S.p.a.

This document contains information that is confidential and proprietary to Leonardo S.p.a. ('the Company') and is supplied on the express condition that it may not be disclosed to any third party, or reproduced in whole or in part, or used for manufacture, or used for any purpose other than for which it is supplied, without the prior written consent of the Company. Every permitted disclosure, reproduction, adaptation or publication of this document in whole or in part and in any manner or form shall prominently contain this notice



AW189 Maintenance Review Board Report

189G0000M006

Issue V

Page 159 of 275

REVISION STATUS	MRB-R TASK NUMBER	TASK CODE	TASK TITLE	SOURCE	INTERVAL	SAMPLING	FEC	APPLICABILITY		ZONE	ACCESS & REMARKS
								AW189	AW189ER		
	651000M-11	GVI	GENERAL VISUAL INSPECTION OF NO'S 1 & 2 TAIL ROTOR DRIVE SHAFT (TRDS) BEARING HOUSING MOUNTING BRACKET FOR FRETTING EVIDENCE NOTE: TO BE ACCOMPLISHED BEFORE TRDS BEARING HOUSING REMOVAL	RDSI (ED) ; CPCP	1600 FH	-	5 ; 8	YES	YES	491 ; 492	ACCESS: 481A ; 491A ; 492A
	651000M-12	DI	DETAILED INSPECTION OF THE TAIL ROTOR DRIVE SHAFT (TRDS) NO. 2, 3 & 4	RDSI (ED) ; CPCP	8 YR ; NOTE_B	1 YR	5 ; 8	YES	YES	492 ; 493	ACCESS: 491A ; 492A ; 493A ; 495A REMOVAL: DRIVE SHAFTS RECOMMENDED
	651000M-13	RST	RESTORATION (OVERHAUL) OF THE TAIL ROTOR DRIVE SHAFT (TRDS) BEARING HOUSINGS NO 1 AND 2 OFF AIRCRAFT	MSI	5200 FH ; 10 YR	-	5 ; 6 ; 8	YES	YES	-	-

© Copyright 2024 Leonardo S.p.a.

This document contains information that is confidential and proprietary to Leonardo S.p.a. ('the Company') and is supplied on the express condition that it may not be disclosed to any third party, or reproduced in whole or in part, or used for manufacture, or used for any purpose other than for which it is supplied, without the prior written consent of the Company. Every permitted disclosure, reproduction, adaptation or publication of this document in whole or in part and in any manner or form shall prominently contain this notice



AW189 Maintenance Review Board Report

189G0000M006

Issue V

Page 160 of 275

REVISION STATUS	MRB-R TASK NUMBER	TASK CODE	TASK TITLE	SOURCE	INTERVAL	SAMPLING	FEC	APPLICABILITY		ZONE	ACCESS & REMARKS
								AW189	AW189ER		
	651000M-14	GVI	GENERAL VISUAL INSPECTION OF NO'S 1 & 2 TAIL ROTOR DRIVE SHAFT (TRDS) BEARING HOUSING MOUNTING SPLINED JOINT SHURLOCK NUT FOR FRETTING EVIDENCE	RDSI (ED) ; CPCP	1600 FH	-	5 ; 8	YES	YES	491 ; 492	ACCESS: 481A ; 491A ; 492A REMOVAL: BEARING SUPPORT HOUSING 1 & 2
MSI - RDSI 65-21-00: INTERMEDIATE GEARBOX											
	652100M-01	GVI	GENERAL VISUAL INSPECTION OF THE INTERMEDIATE GEARBOX NOTE: SHOULD BE ACCOMPLISHED IN CONJUNCTION WITH 652100M-05	MSI ; RDSI (AD)	400 FH	-	5 ; 6	YES	YES	493	ACCESS: 493A
	652100M-02	DI	DETAILED INSPECTION OF INTERMEDIATE GEARBOX	MSI	1600 FH	-	5	YES	YES	-	-
	652100M-03	RST	RESTORATION (OVERHAUL) OF INTERMEDIATE GEARBOX (IGB) OFF AIRCRAFT	MSI	5200 FH ; 10 YR	-	5 ; 6	YES	YES	-	-
	652100M-04	DIS	DISCARD INTERMEDIATE GEARBOX (IGB) CENTRE HOUSING	MSI	NOTE_C	-	5	YES	YES	-	-

© Copyright 2024 Leonardo S.p.a.

This document contains information that is confidential and proprietary to Leonardo S.p.a. ('the Company') and is supplied on the express condition that it may not be disclosed to any third party, or reproduced in whole or in part, or used for manufacture, or used for any purpose other than for which it is supplied, without the prior written consent of the Company. Every permitted disclosure, reproduction, adaptation or publication of this document in whole or in part and in any manner or form shall prominently contain this notice



AW189 Maintenance Review Board Report

189G0000M006

Issue V

Page 161 of 275

REVISION STATUS	MRB-R TASK NUMBER	TASK CODE	TASK TITLE	SOURCE	INTERVAL	SAMPLING	FEC	APPLICABILITY		ZONE	ACCESS & REMARKS
								AW189	AW189ER		
	652100M-05	SV	SERVICING (OIL REPLACEMENT) OF INTERMEDIATE GEARBOX NOTE: SHOULD BE ACCOMPLISHED IN CONJUNCTION WITH 652100M-01 , 654000M-01 AND 654000M-02	MSI	400 FH ; 1 YR	-	5 ; 6	YES	YES	-	-
	652100M-06	DI	DETAILED INSPECTION OF THE INTERMEDIATE GEARBOX (IGB) INPUT AND OUTPUT HOUSINGS	RDSI (ED) ; CPCP	4 YR	1 YR	5	YES	YES	493	ACCESS: 493A
	652100M-07	DI	DETAILED INSPECTION OF THE INTERMEDIATE GEARBOX (IGB) CASE ASSEMBLY FOR FRETTING EVIDENCE	RDSI (ED) ; CPCP	3200 FH	-	5	YES	YES	493	ACCESS: 493A
	652100M-08	VC	VISUAL CHECK OF THE INTERMEDIATE GEARBOX (IGB) OIL LEVEL	MSI	50 FH	-	9	YES	YES	-	-

© Copyright 2024 Leonardo S.p.a.

This document contains information that is confidential and proprietary to Leonardo S.p.a. ('the Company') and is supplied on the express condition that it may not be disclosed to any third party, or reproduced in whole or in part, or used for manufacture, or used for any purpose other than for which it is supplied, without the prior written consent of the Company. Every permitted disclosure, reproduction, adaptation or publication of this document in whole or in part and in any manner or form shall prominently contain this notice



AW189 Maintenance Review Board Report

189G0000M006

Issue V

Page 162 of 275

REVISION STATUS	MRB-R TASK NUMBER	TASK CODE	TASK TITLE	SOURCE	INTERVAL	SAMPLING	FEC	APPLICABILITY		ZONE	ACCESS & REMARKS
								AW189	AW189ER		
	652100M-09	LU	LUBRICATION OF INTERMEDIATE GEARBOX INPUT SPLINE INTERVAL NOTE: TO BE ACCOMPLISHED AT SHAFT NO. 3 OR IGB REMOVAL NOTE: SHOULD BE ACCOMPLISHED IN CONJUNCTION WITH 651000M-04	MSI	NOTE	-	9	YES	YES	-	-
	652100M-10	LU	LUBRICATION OF INTERMEDIATE GEARBOX OUTPUT SPLINE INTERVAL NOTE: TO BE ACCOMPLISHED AT SHAFT NO. 4, IGB OR TGB REMOVAL	MSI	NOTE	-	9	YES	YES	-	-
MSI - RDSI 65-22-00: TAIL GEARBOX											

© Copyright 2024 Leonardo S.p.a.

This document contains information that is confidential and proprietary to Leonardo S.p.a. ('the Company') and is supplied on the express condition that it may not be disclosed to any third party, or reproduced in whole or in part, or used for manufacture, or used for any purpose other than for which it is supplied, without the prior written consent of the Company. Every permitted disclosure, reproduction, adaptation or publication of this document in whole or in part and in any manner or form shall prominently contain this notice



AW189 Maintenance Review Board Report

189G0000M006

Issue V

Page 163 of 275

REVISION STATUS	MRB-R TASK NUMBER	TASK CODE	TASK TITLE	SOURCE	INTERVAL	SAMPLING	FEC	APPLICABILITY		ZONE	ACCESS & REMARKS
								AW189	AW189ER		
	652200M-01	GVI	GENERAL VISUAL INSPECTION OF THE TAIL ROTOR GEARBOX (TGB) NOTE: SHOULD BE ACCOMPLISHED IN CONJUNCTION WITH 652200M-06 AND 652200M-09	MSI ; RDSI (AD)	400 FH	-	5 ; 6	YES	YES	494	ACCESS: 495A ; 496A
	652200M-02	DI	DETAILED INSPECTION OF TAIL ROTOR GEARBOX (TGB)	MSI	1600 FH	-	5	YES	YES	-	-
	652200M-03	RST	RESTORATION (OVERHAUL) OF TAIL ROTOR GEARBOX (TGB) OFF AIRCRAFT	MSI	5200 FH ; 10 YR	-	5 ; 6	YES	YES	-	-
	652200M-04	DIS	DISCARD TAIL ROTOR GEARBOX (TGB) CENTRE HOUSING	MSI	NOTE_C	-	5	YES	YES	-	-
	652200M-05	DIS	DISCARD TAIL ROTOR GEARBOX (TGB) OUTPUT HOUSING	MSI	NOTE_C	-	5	YES	YES	-	-

© Copyright 2024 Leonardo S.p.a.

This document contains information that is confidential and proprietary to Leonardo S.p.a. ('the Company') and is supplied on the express condition that it may not be disclosed to any third party, or reproduced in whole or in part, or used for manufacture, or used for any purpose other than for which it is supplied, without the prior written consent of the Company. Every permitted disclosure, reproduction, adaptation or publication of this document in whole or in part and in any manner or form shall prominently contain this notice



AW189 Maintenance Review Board Report

189G0000M006

Issue V

Page 164 of 275

REVISION STATUS	MRB-R TASK NUMBER	TASK CODE	TASK TITLE	SOURCE	INTERVAL	SAMPLING	FEC	APPLICABILITY		ZONE	ACCESS & REMARKS
								AW189	AW189ER		
	652200M-06	SV	SERVICING (OIL REPLACEMENT) OF TAIL ROTOR GEARBOX (TGB) NOTE: SHOULD BE ACCOMPLISHED IN CONJUNCTION WITH 652200M-01 , 652200M-09 , 654000M-01 AND 654000M-02	MSI	400 FH ; 1 YR	-	5 ; 6	YES	YES	-	-
	652200M-07	DI	DETAILED INSPECTION OF THE TAIL GEARBOX (TGB) INPUT AND CENTRE HOUSING	RDSI (ED) ; CPCP	4 YR	1 YR	5	YES	YES	494	ACCESS: 495A ; 496A
	652200M-08	DI	DETAILED INSPECTION OF THE TAIL GEARBOX (TGB) CASE ASSEMBLY FOR FRETTING EVIDENCE	RDSI (ED) ; CPCP	3200 FH	-	5	YES	YES	494	ACCESS: 495A ; 496A
	652200M-09	DI	DETAILED INSPECTION OF THE TAIL ROTOR GEARBOX OUTPUT SHAFT SPLINE FOR FRETTING EVIDENCE	RDSI (ED) ; CPCP	3200 FH	-	5	YES	YES	494	ACCESS: 495A ; 496A REMOVAL: TAIL ROTOR HUB
	652200M-10	DI	DETAILED INSPECTION OF THE TAIL ROTOR GEARBOX (TGB) OUTPUT SHAFT CONICAL RINGS FOR FRETTING EVIDENCE	RDSI (ED) ; CPCP	1600 FH	-	5	YES	YES	494	ACCESS: 495A ; 496A

© Copyright 2024 Leonardo S.p.a.

This document contains information that is confidential and proprietary to Leonardo S.p.a. ('the Company') and is supplied on the express condition that it may not be disclosed to any third party, or reproduced in whole or in part, or used for manufacture, or used for any purpose other than for which it is supplied, without the prior written consent of the Company. Every permitted disclosure, reproduction, adaptation or publication of this document in whole or in part and in any manner or form shall prominently contain this notice



AW189 Maintenance Review Board Report

189G0000M006

Issue V

Page 165 of 275

REVISION STATUS	MRB-R TASK NUMBER	TASK CODE	TASK TITLE	SOURCE	INTERVAL	SAMPLING	FEC	APPLICABILITY		ZONE	ACCESS & REMARKS
								AW189	AW189ER		
	652200M-11	FC	FUNCTIONAL CHECK (TORQUE CHECK) OF THE FASTENERS SECURING THE FLYING CONTROL COMPONENTS TO THE TAIL ROTOR GEARBOX	RDSI (ED) ; CPCP	3200 FH	-	5	YES	YES	494	ACCESS: 495A ; 496A
	652200M-12	DI	DETAILED INSPECTION OF THE TAIL ROTOR GEARBOX OUTPUT GEAR (EXTERNAL PART OF SHAFT ONLY)	RDSI (ED) ; CPCP	4 YR	1 YR	5	YES	YES	494	ACCESS: 495A ; 496A
	652200M-13	VC	VISUAL CHECK OF THE TAIL GEARBOX (TGB) OIL LEVEL	MSI	50 FH	-	9	YES	YES	-	-
MSI 65-40-00: INDICATING											
	654000M-01	GVI	GENERAL VISUAL INSPECTION OF INTERMEDIATE GEARBOX (IGB) / TAIL GEARBOX (TGB) OIL LEVEL SIGHT GLASS NOTE: TO BE ACCOMPLISHED IN CONJUNCTION WITH 652100M-05 AND 652200M-06	MSI	400 FH ; 1 YR	-	9	YES	YES	-	-

© Copyright 2024 Leonardo S.p.a.

This document contains information that is confidential and proprietary to Leonardo S.p.a. ('the Company') and is supplied on the express condition that it may not be disclosed to any third party, or reproduced in whole or in part, or used for manufacture, or used for any purpose other than for which it is supplied, without the prior written consent of the Company. Every permitted disclosure, reproduction, adaptation or publication of this document in whole or in part and in any manner or form shall prominently contain this notice



AW189 Maintenance Review Board Report

189G0000M006

Issue V

Page 166 of 275

REVISION STATUS	MRB-R TASK NUMBER	TASK CODE	TASK TITLE	SOURCE	INTERVAL	SAMPLING	FEC	APPLICABILITY		ZONE	ACCESS & REMARKS
								AW189	AW189ER		
	654000M-02	OC	OPERATIONAL CHECK OF INTERMEDIATE GEARBOX (IGB) / TAIL GEARBOX (TGB) LOW OIL LEVEL INDICATION NOTE: TO BE ACCOMPLISHED IN CONJUNCTION WITH 652100M-05 AND 652200M-06	MSI	400 FH ; 1 YR	-	9	YES	YES	-	-
	654000M-03	DI	DETAILED INSPECTION OF INTERMEDIATE GEARBOX / TAIL GEARBOX MAGNETIC CHIP DETECTORS NOTE: SHOULD BE ACCOMPLISHED IN CONJUNCTION WITH 652100M-06 AND 652200M-07	MSI	400 FH ; 1 YR	-	8	YES	YES	-	-

© Copyright 2024 Leonardo S.p.a.

This document contains information that is confidential and proprietary to Leonardo S.p.a. ('the Company') and is supplied on the express condition that it may not be disclosed to any third party, or reproduced in whole or in part, or used for manufacture, or used for any purpose other than for which it is supplied, without the prior written consent of the Company. Every permitted disclosure, reproduction, adaptation or publication of this document in whole or in part and in any manner or form shall prominently contain this notice



AW189 Maintenance Review Board Report

189G0000M006

Issue V

Page 167 of 275

REVISION STATUS	MRB-R TASK NUMBER	TASK CODE	TASK TITLE	SOURCE	INTERVAL	SAMPLING	FEC	APPLICABILITY		ZONE	ACCESS & REMARKS
								AW189	AW189ER		
	654000M-04	FC	FUNCTIONAL CHECK (CALIBRATION CHECK) OF INTERMEDIATE GEARBOX (IGB) OIL TEMPERATURE SENSOR OFF AIRCRAFT NOTE: CREDIT FOR ACCOMPLISHMENT CAN BE TAKEN FROM 652100M-03	MSI	6400 FH	-	8	YES	YES	-	-
	654000M-05	OC	OPERATIONAL CHECK OF INTERMEDIATE GEARBOX (IGB) / TAIL GEARBOX (TGB) FUZZ BURNER SYSTEM	MSI	1600 FH ; 4Y	-	8 ; 9	YES	YES	-	-
	654000M-06	-	TASK DELETED WITH MRBR ISSUE C	-	-	-	-	-	-	-	-

© Copyright 2024 Leonardo S.p.a.

This document contains information that is confidential and proprietary to Leonardo S.p.a. ('the Company') and is supplied on the express condition that it may not be disclosed to any third party, or reproduced in whole or in part, or used for manufacture, or used for any purpose other than for which it is supplied, without the prior written consent of the Company. Every permitted disclosure, reproduction, adaptation or publication of this document in whole or in part and in any manner or form shall prominently contain this notice



AW189 Maintenance Review Board Report

189G0000M006

Issue V

Page 168 of 275

REVISION STATUS	MRB-R TASK NUMBER	TASK CODE	TASK TITLE	SOURCE	INTERVAL	SAMPLING	FEC	APPLICABILITY		ZONE	ACCESS & REMARKS
								AW189	AW189ER		
	654000M-07	FC	FUNCTIONAL CHECK (CALIBRATION CHECK) OF TAIL ROTOR GEARBOX (TGB) OIL TEMPERATURE SENSOR OFF AIRCRAFT NOTE: CREDIT FOR ACCOMPLISHMENT CAN BE TAKEN FROM 652200M-03	MSI	6400 FH	-	8	YES	YES	-	-
ATA 67: ROTOR FLIGHT CONTROLS											
MSI 67-11-00: COLLECTIVE PITCH ROTOR CONTROL											
	671100M-01	DI	DETAILED INSPECTION OF COLLECTIVE CONTROL LINKAGES	MSI	1600 FH ; 2 YR	-	5	YES	YES	-	-
	671100M-02	DI	DETAILED INSPECTION OF COLLECTIVE COCKPIT CONTROLS	MSI	3200 FH ; 4 YR	-	5 ; 6	YES	YES	-	-
	671100M-03	-	TASK DELETED WITH MRBR ISSUE C	-	-	-	-	-	-	-	-

© Copyright 2024 Leonardo S.p.a.

This document contains information that is confidential and proprietary to Leonardo S.p.a. ('the Company') and is supplied on the express condition that it may not be disclosed to any third party, or reproduced in whole or in part, or used for manufacture, or used for any purpose other than for which it is supplied, without the prior written consent of the Company. Every permitted disclosure, reproduction, adaptation or publication of this document in whole or in part and in any manner or form shall prominently contain this notice



AW189 Maintenance Review Board Report

189G0000M006

Issue V

Page 169 of 275

REVISION STATUS	MRB-R TASK NUMBER	TASK CODE	TASK TITLE	SOURCE	INTERVAL	SAMPLING	FEC	APPLICABILITY		ZONE	ACCESS & REMARKS
								AW189	AW189ER		
	671100M-04	FC	FUNCTIONAL CHECK (FORCE MEASUREMENT) OF THE FLYING CONTROLS MOVEMENT NOTE: IDENTICAL TO 671200M-04 , 671300M-02 AND 672000M-03	MSI	1600 FH	-	5	YES	YES	-	-
MSI 67-12-00: CYCLIC PITCH ROTOR CONTROL											
	671200M-01	DI	DETAILED INSPECTION OF CYCLIC CONTROL LINKAGES	MSI	1600 FH ; 2 YR	-	5 ; 6 ; 8	YES	YES	-	-
	671200M-02	DI	DETAILED INSPECTION OF CYCLIC COCKPIT CONTROLS	MSI	3200 FH ; 4 YR	-	5 ; 6	YES	YES	-	-
	671200M-03	-	TASK DELETED WITH MRBR ISSUE C	-	-	-	-	-	-	-	-
	671200M-04	FC	FUNCTIONAL CHECK (FORCE MEASUREMENT) OF THE FLYING CONTROLS MOVEMENT NOTE: IDENTICAL TO 671100M-04 , 671300M-02 AND 672000M-03	MSI	1600 FH	-	5	YES	YES	-	-
MSI 67-13-00: MIXING CONTROL											

© Copyright 2024 Leonardo S.p.a.

This document contains information that is confidential and proprietary to Leonardo S.p.a. ('the Company') and is supplied on the express condition that it may not be disclosed to any third party, or reproduced in whole or in part, or used for manufacture, or used for any purpose other than for which it is supplied, without the prior written consent of the Company. Every permitted disclosure, reproduction, adaptation or publication of this document in whole or in part and in any manner or form shall prominently contain this notice



AW189 Maintenance Review Board Report

189G0000M006

Issue V

Page 170 of 275

REVISION STATUS	MRB-R TASK NUMBER	TASK CODE	TASK TITLE	SOURCE	INTERVAL	SAMPLING	FEC	APPLICABILITY		ZONE	ACCESS & REMARKS
								AW189	AW189ER		
	671300M-01	DI	DETAILED INSPECTION OF MIXED CONTROL LINKAGES	MSI	1600 FH ; 2 YR	-	5 ; 6 ; 8 ; 9	YES	YES	-	-
	671300M-02	FC	FUNCTIONAL CHECK (FORCE MEASUREMENT) OF THE FLYING CONTROLS MOVEMENT NOTE: IDENTICAL TO 671100M-04 , 671200M-04 AND 672000M-03	MSI	1600 FH	-	5	YES	YES	-	-
MSI 67-20-00: ANTI-TORQUE ROTOR CONTROL (YAW CONTROL)											
	672000M-01	DI	DETAILED INSPECTION OF YAW CONTROL LINKAGES	MSI	1600 FH ; 2 YR ; NOTE_B	-	5 ; 6 ; 8	YES	YES	-	-
	672000M-02	DI	DETAILED INSPECTION OF YAW COCKPIT CONTROLS	MSI	1600 FH ; 2 YR	-	5 ; 6	YES	YES	-	-

© Copyright 2024 Leonardo S.p.a.

This document contains information that is confidential and proprietary to Leonardo S.p.a. ('the Company') and is supplied on the express condition that it may not be disclosed to any third party, or reproduced in whole or in part, or used for manufacture, or used for any purpose other than for which it is supplied, without the prior written consent of the Company. Every permitted disclosure, reproduction, adaptation or publication of this document in whole or in part and in any manner or form shall prominently contain this notice



AW189 Maintenance Review Board Report

189G0000M006

Issue V

Page 171 of 275

REVISION STATUS	MRB-R TASK NUMBER	TASK CODE	TASK TITLE	SOURCE	INTERVAL	SAMPLING	FEC	APPLICABILITY		ZONE	ACCESS & REMARKS
								AW189	AW189ER		
	672000M-03	FC	FUNCTIONAL CHECK (FORCE MEASUREMENT) OF THE FLYING CONTROLS MOVEMENT NOTE: IDENTICAL TO 671100M-04 , 671200M-04 AND 671300M-02	MSI	1600 FH	-	5	YES	YES	-	-
MSI 67-30-00: SERVO-CONTROL SYSTEM											
	673000M-01	GVI	GENERAL VISUAL INSPECTION OF MAIN ROTOR SERVO-ACTUATOR INSTALLATION	MSI	400 FH	-	5 ; 6	YES	YES	-	-
	673000M-02	RST	RESTORATION (OVERHAUL) OF MAIN ROTOR SERVO-ACTUATOR INTERVAL NOTE: 1000 FH FOR P/N 4F6730V00331 3000 FH FOR P/N 8G6730V00331 OFF AIRCRAFT	MSI	NOTE	-	5 ; 6 ; 8	YES	YES	-	-
	673000M-03	OC	OPERATIONAL CHECK OF THE MAIN ROTOR ACTUATOR (MRA) ANTI-JAM DEVICE AND INDICATION	MSI	800 FH	-	8	YES	YES	-	-

© Copyright 2024 Leonardo S.p.a.

This document contains information that is confidential and proprietary to Leonardo S.p.a. ('the Company') and is supplied on the express condition that it may not be disclosed to any third party, or reproduced in whole or in part, or used for manufacture, or used for any purpose other than for which it is supplied, without the prior written consent of the Company. Every permitted disclosure, reproduction, adaptation or publication of this document in whole or in part and in any manner or form shall prominently contain this notice



AW189 Maintenance Review Board Report

189G0000M006

Issue V

Page 172 of 275

REVISION STATUS	MRB-R TASK NUMBER	TASK CODE	TASK TITLE	SOURCE	INTERVAL	SAMPLING	FEC	APPLICABILITY		ZONE	ACCESS & REMARKS
								AW189	AW189ER		
	673000M-04	DI	DETAILED INSPECTION OF MAIN ROTOR SERVO-ACTUATOR MOUNTING BOLTS (UPPER AND LOWER) AND MAIN GEAR BOX (MGB) BRACKETS	MSI	3200 FH	-	5	YES	YES	-	-
	673000M-05	GVI	GENERAL VISUAL INSPECTION OF TAIL ROTOR SERVO-ACTUATOR NOTE: IDENTICAL TO 221000M-02	MSI	400 FH	-	5 ; 6	YES	YES	-	-
	673000M-06	RST	RESTORATION (OVERHAUL) OF TAIL ROTOR SERVO-ACTUATOR OFF AIRCRAFT NOTE: IDENTICAL TO 221000M-01	MSI	5000 FH	-	5 ; 6 ; 8	YES	YES	-	-
	673000M-07	OC	OPERATIONAL CHECK OF THE TAIL ROTOR ACTUATOR (TRA) ANTI-JAM DEVICE AND INDICATION	MSI	800 FH	-	8	YES	YES	-	-

© Copyright 2024 Leonardo S.p.a.

This document contains information that is confidential and proprietary to Leonardo S.p.a. ('the Company') and is supplied on the express condition that it may not be disclosed to any third party, or reproduced in whole or in part, or used for manufacture, or used for any purpose other than for which it is supplied, without the prior written consent of the Company. Every permitted disclosure, reproduction, adaptation or publication of this document in whole or in part and in any manner or form shall prominently contain this notice



AW189 Maintenance Review Board Report

189G0000M006

Issue V

Page 173 of 275

REVISION STATUS	MRB-R TASK NUMBER	TASK CODE	TASK TITLE	SOURCE	INTERVAL	SAMPLING	FEC	APPLICABILITY		ZONE	ACCESS & REMARKS
								AW189	AW189ER		
	673000M-08	-	TASK DELETED WITH MRBR ISSUE D	-	-	-	-	-	-	-	-
ATA 71: POWER PLANT INSTALLATION											
MSI 71-20-00: MOUNTS											
	712000M-01	DI	DETAILED INSPECTION OF REAR ENGINES MOUNTS INBOARD / OUTBOARD (LINK AND BRACKET BEARINGS) AND CONNECTION BOLTS NOTE: CAN ALSO BE ACCOMPLISHED AT ENGINE REMOVAL	MSI	2 YR	-	9	YES	YES	-	REMOVAL: ENGINE AND CONENCTION BOLTS
MSI 71-30-00: FIRE SEALS											
	713000M-01	GVI	GENERAL VISUAL INSPECTION OF THE ENGINE BAY FIRE SEALS NOTE: SHOULD BE ACCOMPLISHED IN CONJUNCTION WITH 713000M-02	MSI	400 FH	-	9	YES	YES	-	-

© Copyright 2024 Leonardo S.p.a.

This document contains information that is confidential and proprietary to Leonardo S.p.a. ('the Company') and is supplied on the express condition that it may not be disclosed to any third party, or reproduced in whole or in part, or used for manufacture, or used for any purpose other than for which it is supplied, without the prior written consent of the Company. Every permitted disclosure, reproduction, adaptation or publication of this document in whole or in part and in any manner or form shall prominently contain this notice



AW189 Maintenance Review Board Report

189G0000M006

Issue V

Page 174 of 275

REVISION STATUS	MRB-R TASK NUMBER	TASK CODE	TASK TITLE	SOURCE	INTERVAL	SAMPLING	FEC	APPLICABILITY		ZONE	ACCESS & REMARKS
								AW189	AW189ER		
	713000M-02	GVI	GENERAL VISUAL INSPECTION OF THE APU BAY FIRE SEALS NOTE: SHOULD BE ACCOMPLISHED IN CONJUNCTION WITH 713000M-01	MSI	400 FH	-	9	YES	YES	-	-
	713000M-03	GVI	GENERAL VISUAL INSPECTION OF THE ENGINE INTAKE SEALS INTERVAL NOTE: TO BE ACCOMPLISHED AT ENGINE REMOVAL OR 2 YR	MSI	NOTE	-	9	YES	YES	-	-
MSI 71-40-00: ATTACHMENT FITTINGS (TASK TRANSFERRED TO ZONAL)											
	714000M-01	-	TASK DELETED WITH MRBR ISSUE C	-	-	-	-	-	-	-	-
MSI 71-60-00: AIR INTAKES											
	716000M-01	GVI	GENERAL VISUAL INSPECTION OF THE AIR INTAKE ASSEMBLY	MSI	800 FH	-	6 ; 9	YES	YES	-	-
	716000M-02	SDI	SPECIAL DETAILED INSPECTION (TAP TEST) OF ALL INTAKE ASSEMBLY	MSI	800 FH	-	6 ; 9	YES	YES	-	-

© Copyright 2024 Leonardo S.p.a.

This document contains information that is confidential and proprietary to Leonardo S.p.a. ('the Company') and is supplied on the express condition that it may not be disclosed to any third party, or reproduced in whole or in part, or used for manufacture, or used for any purpose other than for which it is supplied, without the prior written consent of the Company. Every permitted disclosure, reproduction, adaptation or publication of this document in whole or in part and in any manner or form shall prominently contain this notice



AW189 Maintenance Review Board Report

189G0000M006

Issue V

Page 175 of 275

REVISION STATUS	MRB-R TASK NUMBER	TASK CODE	TASK TITLE	SOURCE	INTERVAL	SAMPLING	FEC	APPLICABILITY		ZONE	ACCESS & REMARKS
								AW189	AW189ER		
MSI 71-62-00: ENGINE INLET BARRIER FILTER KIT											
	716200M-01	DI	DETAILED INSPECTION OF THE ENGINE INLET BARRIER FILTERS	MSI	400 FH ; 1 YR	-	6 ; 9	WITH ENGINE INLET BARRIER FILTER KIT	WITH ENGINE INLET BARRIER FILTER KIT	-	-
	716200M-02	FC	FUNCTIONAL CHECK OF THE ENGINE INLET BARRIER FILTER BY PASS MECHANISM	MSI	400 FH ; 1 YR	-	6 ; 9	WITH ENGINE INLET BARRIER FILTER KIT	WITH ENGINE INLET BARRIER FILTER KIT	-	-
MSI 71-70-00: ENGINE DRAINS											
	717000M-01	OC	OPERATIONAL CHECK OF LH & RH ENGINE DECK DRAINS	MSI	1600 FH	-	9	YES	YES	-	-
	717000M-02	OC	OPERATIONAL CHECK OF APU DECK DRAINS	MSI	1600 FH	-	9	YES	YES	-	-
	717000M-03	FC	FUNCTIONAL CHECK (PRESSURE CHECK) OF LH & RH ENGINE COMBUSTOR DRAIN	MSI	1600 FH	-	9	PRE BT 189-200	PRE BT 189-200	-	-
	717000M-04	FC	FUNCTIONAL CHECK (PRESSURE CHECK) OF APU COMBUSTOR DRAIN	MSI	1600 FH	-	9	YES	YES	-	-

© Copyright 2024 Leonardo S.p.a.

This document contains information that is confidential and proprietary to Leonardo S.p.a. ('the Company') and is supplied on the express condition that it may not be disclosed to any third party, or reproduced in whole or in part, or used for manufacture, or used for any purpose other than for which it is supplied, without the prior written consent of the Company. Every permitted disclosure, reproduction, adaptation or publication of this document in whole or in part and in any manner or form shall prominently contain this notice



AW189 Maintenance Review Board Report

189G0000M006

Issue V

Page 176 of 275

REVISION STATUS	MRB-R TASK NUMBER	TASK CODE	TASK TITLE	SOURCE	INTERVAL	SAMPLING	FEC	APPLICABILITY		ZONE	ACCESS & REMARKS
								AW189	AW189ER		
	717000M-05	OC	OPERATIONAL CHECK OF THE APU GEARBOX SEAL DRAIN	MSI	1600 FH	-	9	YES	YES	-	-
	717000M-06	DI	DETAILED INSPECTION OF LH & RH ENGINE COMBUSTOR DRAINS	MSI	1600 FH	-	9	YES	YES	-	-
ATA 72: ENGINE											
MSI 72-10-00: OUTPUT SHAFT MODULE (M04)											
	721000M-01	RST	RESTORATION (OVERHAUL) OF ENGINE OUTPUT SHAFT MODULE (M04) OFF AIRCRAFT	MSI	3000 FH	-	6	WITH ANETO-1K ENGINE INSTALLATION	NO	-	-
MSI 72-30-00: COLD SECTION MODULE											
	723000M-01	DI	DETAILED INSPECTION OF RADIAL DRIVESHAFT NOTE: TO BE ACCOMPLISHED BEFORE 723000M-03	MSI	1600 FH	-	6	WITH CT7-2E1 ENGINE INSTALLATION	WITH CT7-2E1 ENGINE INSTALLATION	-	-
	723000M-02	GVI	GENERAL VISUAL INSPECTION OF INLET PARTICLE SEPARATOR BLOWER	MSI	400 FH	-	9	WITH CT7-2E1 ENGINE INSTALLATION	WITH CT7-2E1 ENGINE INSTALLATION	-	-

© Copyright 2024 Leonardo S.p.a.

This document contains information that is confidential and proprietary to Leonardo S.p.a. ('the Company') and is supplied on the express condition that it may not be disclosed to any third party, or reproduced in whole or in part, or used for manufacture, or used for any purpose other than for which it is supplied, without the prior written consent of the Company. Every permitted disclosure, reproduction, adaptation or publication of this document in whole or in part and in any manner or form shall prominently contain this notice



AW189 Maintenance Review Board Report

189G0000M006

Issue V

Page 177 of 275

REVISION STATUS	MRB-R TASK NUMBER	TASK CODE	TASK TITLE	SOURCE	INTERVAL	SAMPLING	FEC	APPLICABILITY		ZONE	ACCESS & REMARKS
								AW189	AW189ER		
	723000M-03	SDI	SPECIAL DETAILED INSPECTION (BOROSCOPE INSPECTION) OF ENGINE COMPRESSOR SECTION NOTE: TO BE ACCOMPLISHED AFTER 723000M-01	MSI	1600 FH	-	6	WITH CT7-2E1 ENGINE INSTALLATION	WITH CT7-2E1 ENGINE INSTALLATION	-	-
	723000M-04	RST	RESTORATION (CHEMICAL AND WATER WASH) OF ENGINE COMPRESSOR ROTOR AND STATOR ASSEMBLY NOTE: SHOULD BE ACCOMPLISHED IN CONJUNCTION WITH 492000M-02 AND 492000M-03	MSI	150 FH ; NOTE_B	-	6	WITH CT7-2E1 ENGINE INSTALLATION	WITH CT7-2E1 ENGINE INSTALLATION	-	-
	723000M-05	DIS	DISCARD ENGINE COMPRESSOR ROTOR ASSEMBLY	MSI	NOTE_A	-	5	WITH CT7-2E1 ENGINE INSTALLATION	WITH CT7-2E1 ENGINE INSTALLATION	-	-
	723000M-06	DI	DETAILED INSPECTION OF ACTUATING SYSTEM LINKAGE ASSEMBLY, ACTUATING RINGS, AND LEVERS NOTE: COVERS 753000M-01	MSI	400 FH	-	6	WITH CT7-2E1 ENGINE INSTALLATION	WITH CT7-2E1 ENGINE INSTALLATION	-	-

© Copyright 2024 Leonardo S.p.a.

This document contains information that is confidential and proprietary to Leonardo S.p.a. ('the Company') and is supplied on the express condition that it may not be disclosed to any third party, or reproduced in whole or in part, or used for manufacture, or used for any purpose other than for which it is supplied, without the prior written consent of the Company. Every permitted disclosure, reproduction, adaptation or publication of this document in whole or in part and in any manner or form shall prominently contain this notice



AW189 Maintenance Review Board Report

189G0000M006

Issue V

Page 178 of 275

REVISION STATUS	MRB-R TASK NUMBER	TASK CODE	TASK TITLE	SOURCE	INTERVAL	SAMPLING	FEC	APPLICABILITY		ZONE	ACCESS & REMARKS
								AW189	AW189ER		
	723000M-07	GVI	GENERAL VISUAL INSPECTION OF STAGE 4 COMPRESSOR BLEED LINE	MSI	400 FH	-	9	WITH CT7-2E1 ENGINE INSTALLATION	WITH CT7-2E1 ENGINE INSTALLATION	-	-
	723000M-08	DI	DETAILED INSPECTION OF DIFFUSER / MIDFRAME ASSEMBLY	MSI	400 FH	-	9	WITH CT7-2E1 ENGINE INSTALLATION	WITH CT7-2E1 ENGINE INSTALLATION	-	-
MSI 72-30-01: COMPRESSION SECTION (M01)											
	723001M-01	RST	RESTORATION (CHEMICAL AND WATER WASH) OF ENGINE COMPRESSOR	MSI	100 FH ; NOTE_B	-	6	WITH ANETO-1K ENGINE INSTALLATION	NO	-	-
	723001M-02	RST	RESTORATION (OVERHAUL) OF ENGINE COMPRESSOR MODULE (M01) OFF AIRCRAFT	MSI	3000 FH	-	6	WITH ANETO-1K ENGINE INSTALLATION	NO	-	-
	723001M-03	SDI	SPECIAL DETAILED INSPECTION (BOROSCOPE INSPECTION) OF ENGINE COMPRESSOR SECTION INTERVAL NOTE: 800FH REDUCED TO 100FH IN CASE OF EROSIIVE ENVIRONMENT	MSI	NOTE	-	6	WITH ANETO-1K ENGINE INSTALLATION	NO	-	-
	723001M-04	DIS	DISCARD COMPRESSOR MODULE AXIAL WHEELS AND IMPELLER	MSI	NOTE_A	-	5	WITH ANETO-1K ENGINE INSTALLATION	NO	-	-

© Copyright 2024 Leonardo S.p.a.

This document contains information that is confidential and proprietary to Leonardo S.p.a. ('the Company') and is supplied on the express condition that it may not be disclosed to any third party, or reproduced in whole or in part, or used for manufacture, or used for any purpose other than for which it is supplied, without the prior written consent of the Company. Every permitted disclosure, reproduction, adaptation or publication of this document in whole or in part and in any manner or form shall prominently contain this notice



AW189 Maintenance Review Board Report

189G0000M006

Issue V

Page 179 of 275

REVISION STATUS	MRB-R TASK NUMBER	TASK CODE	TASK TITLE	SOURCE	INTERVAL	SAMPLING	FEC	APPLICABILITY		ZONE	ACCESS & REMARKS
								AW189	AW189ER		
	723001M-05	VC	VISUAL CHECK OF P2.5 PIPES FOR DISCONNECTION NOTE: SHOULD BE ACCOMPLISHED IN CONJUNCTION WITH 723001M-06, 726001M-01, 726001M-03, 742001M-02, 753001M-02 AND 755000M-01	MSI	50 FH	-	9	WITH ANETO-1K ENGINE INSTALLATION	NO	-	-
	723001M-06	GVI	GENERAL VISUAL INSPECTION OF ENGINE (COMPRESSOR MODULE M01) NOTE: SHOULD BE ACCOMPLISHED IN CONJUNCTION WITH 723001M-05, 726001M-01, 726001M-03, 742001M-02, 753001M-02 AND 755000M-01	MSI	50 FH	-	6	WITH ANETO-1K ENGINE INSTALLATION	NO	-	-
MSI 72-40-00: HOT SECTION MODULE											
	724000M-01	SDI	SPECIAL DETAILED INSPECTION (BOROSCOPE INSPECTION) OF THE COMBUSTION LINER	MSI	1600 FH	-	6	WITH CT7-2E1 ENGINE INSTALLATION	WITH CT7-2E1 ENGINE INSTALLATION	-	-

© Copyright 2024 Leonardo S.p.a.

This document contains information that is confidential and proprietary to Leonardo S.p.a. ('the Company') and is supplied on the express condition that it may not be disclosed to any third party, or reproduced in whole or in part, or used for manufacture, or used for any purpose other than for which it is supplied, without the prior written consent of the Company. Every permitted disclosure, reproduction, adaptation or publication of this document in whole or in part and in any manner or form shall prominently contain this notice



AW189 Maintenance Review Board Report

189G0000M006

Issue V

Page 180 of 275

REVISION STATUS	MRB-R TASK NUMBER	TASK CODE	TASK TITLE	SOURCE	INTERVAL	SAMPLING	FEC	APPLICABILITY		ZONE	ACCESS & REMARKS
								AW189	AW189ER		
	724000M-02	SDI	SPECIAL DETAILED INSPECTION (BOROSCOPE INSPECTION) OF THE STAGE-1 NOZZLE	MSI	1600 FH	-	9	WITH CT7-2E1 ENGINE INSTALLATION	WITH CT7-2E1 ENGINE INSTALLATION	-	-
	724000M-03	SDI	SPECIAL DETAILED INSPECTION (BOROSCOPE INSPECTION) OF GAS GENERATOR TURBINE	MSI	1600 FH	-	6	WITH CT7-2E1 ENGINE INSTALLATION	WITH CT7-2E1 ENGINE INSTALLATION	-	-
	724000M-04	DIS	DISCARD GAS GENERATOR ROTOR	MSI	NOTE_A	-	5	WITH CT7-2E1 ENGINE INSTALLATION	WITH CT7-2E1 ENGINE INSTALLATION	-	-
MSI 72-40-01: HOT SECTION MODULE (M02)											
	724001M-01	SDI	SPECIAL DETAILED INSPECTION (BOROSCOPE INSPECTION) OF COMBUSTION CHAMBER AND HP1 NOZZLE AND BLADES INTERVAL NOTE: 800 FH REDUCED TO 200 FH IN CASE OF EROSIIVE ENVIRONEMENT	MSI	NOTE	-	6; 9	WITH ANETO-1K ENGINE INSTALLATION	NO	-	-

© Copyright 2024 Leonardo S.p.a.

This document contains information that is confidential and proprietary to Leonardo S.p.a. ('the Company') and is supplied on the express condition that it may not be disclosed to any third party, or reproduced in whole or in part, or used for manufacture, or used for any purpose other than for which it is supplied, without the prior written consent of the Company. Every permitted disclosure, reproduction, adaptation or publication of this document in whole or in part and in any manner or form shall prominently contain this notice



AW189 Maintenance Review Board Report

189G0000M006

Issue V

Page 181 of 275

REVISION STATUS	MRB-R TASK NUMBER	TASK CODE	TASK TITLE	SOURCE	INTERVAL	SAMPLING	FEC	APPLICABILITY		ZONE	ACCESS & REMARKS
								AW189	AW189ER		
	724001M-02	RST	RESTORATION (OVERHAUL) OF ENGINE HOT SECTION MODULE (M02) OFF AIRCRAFT NOTE: IDENTICAL TO 731001M-04	MSI	3000 FH	-	6	WITH ANETO-1K ENGINE INSTALLATION	NO	-	-
	724001M-03	DIS	DISCARD ENGINE HOT SECTION MODULE (M02) HP DISCS	MSI	NOTE_A	-	5	WITH ANETO-1K ENGINE INSTALLATION	NO	-	-
MSI 72-50-00: POWER TURBINE MODULE											
	725000M-01	DIS	DISCARD POWER TURBINE ROTOR ASSEMBLY PARTS	MSI	NOTE_A	-	5	WITH CT7-2E1 ENGINE INSTALLATION	WITH CT7-2E1 ENGINE INSTALLATION	-	-
	725000M-02	GVI	GENERAL VISUAL INSPECTION OF THE EXHAUST FRAME AND AROUND THE C-SUMP HOUSING	MSI	400 FH	-	9	WITH CT7-2E1 ENGINE INSTALLATION	WITH CT7-2E1 ENGINE INSTALLATION	-	-
MSI 72-50-01: POWER TURBINE MODULE (M03)											

© Copyright 2024 Leonardo S.p.a.

This document contains information that is confidential and proprietary to Leonardo S.p.a. ('the Company') and is supplied on the express condition that it may not be disclosed to any third party, or reproduced in whole or in part, or used for manufacture, or used for any purpose other than for which it is supplied, without the prior written consent of the Company. Every permitted disclosure, reproduction, adaptation or publication of this document in whole or in part and in any manner or form shall prominently contain this notice



AW189 Maintenance Review Board Report

189G0000M006

Issue V

Page 182 of 275

REVISION STATUS	MRB-R TASK NUMBER	TASK CODE	TASK TITLE	SOURCE	INTERVAL	SAMPLING	FEC	APPLICABILITY		ZONE	ACCESS & REMARKS
								AW189	AW189ER		
	725001M-01	RST	RESTORATION (OVERHAUL) OF ENGINE POWER TURBINE MODULE (M03) OFF AIRCRAFT	MSI	3000 FH	-	6	WITH ANETO-1K ENGINE INSTALLATION	NO	-	-
	725001M-02	DIS	DISCARD ENGINE POWER TURBINE MODULE (M03) DISCS	MSI	NOTE_A	-	5	WITH ANETO-1K ENGINE INSTALLATION	NO	-	-
MSI 72-60-00: ACCESSORY SECTION MODULE											
	726000M-01	GVI	GENERAL VISUAL INSPECTION OF THE ACCESSORY GEARBOX	MSI	400 FH	-	6 ; 9	WITH CT7-2E1 ENGINE INSTALLATION	WITH CT7-2E1 ENGINE INSTALLATION	-	-
MSI 72-60-01: ACCESSORY GEARBOX MODULE (M05)											
	726001M-01	DI	DETAILED INSPECTION OF THE ENGINE OIL TANK MECHANICAL MAGNETIC PLUG NOTE: SHOULD BE ACCOMPLISHED IN CONJUNCTION WITH 723001M-05, 723001M-06, 726001M-03, 742001M-02, 753001M-02 AND 755000M-01	MSI	50 FH	-	9	WITH ANETO-1K ENGINE INSTALLATION	NO	-	-

© Copyright 2024 Leonardo S.p.a.

This document contains information that is confidential and proprietary to Leonardo S.p.a. ('the Company') and is supplied on the express condition that it may not be disclosed to any third party, or reproduced in whole or in part, or used for manufacture, or used for any purpose other than for which it is supplied, without the prior written consent of the Company. Every permitted disclosure, reproduction, adaptation or publication of this document in whole or in part and in any manner or form shall prominently contain this notice



AW189 Maintenance Review Board Report

189G0000M006

Issue V

Page 183 of 275

REVISION STATUS	MRB-R TASK NUMBER	TASK CODE	TASK TITLE	SOURCE	INTERVAL	SAMPLING	FEC	APPLICABILITY		ZONE	ACCESS & REMARKS
								AW189	AW189ER		
	726001M-02	RST	RESTORATION (OVERHAUL) OF ENGINE ACCESSORY GEARBOX MODULE (M05) OFF AIRCRAFT NOTE: IDENTICAL TO 731001M-02	MSI	3000 FH	-	6; 9	WITH ANETO-1K ENGINE INSTALLATION	NO	-	-
	726001M-03	GVI	GENERAL VISUAL INSPECTION OF ENGINE (GEARBOX MODULE) NOTE: SHOULD BE ACCOMPLISHED IN CONJUNCTION WITH 723001M-05, 723001M-06, 726001M-01, 742001M-02, 753001M-02 AND 755000M-01	MSI	50 FH	-	6	WITH ANETO-1K ENGINE INSTALLATION	NO	-	-
ATA 73: ENGINE FUEL AND CONTROL											
MSI 73-10-00: ENGINE FUEL DISTRIBUTION											
	731000M-01	RST	RESTORATION (HEAT CLEANING) OF FUEL INJECTORS OFF AIRCRAFT	MSI	1600 FH	-	9	WITH CT7-2E1 ENGINE INSTALLATION	WITH CT7-2E1 ENGINE INSTALLATION	-	REMOVAL: ENGINES

© Copyright 2024 Leonardo S.p.a.

This document contains information that is confidential and proprietary to Leonardo S.p.a. ('the Company') and is supplied on the express condition that it may not be disclosed to any third party, or reproduced in whole or in part, or used for manufacture, or used for any purpose other than for which it is supplied, without the prior written consent of the Company. Every permitted disclosure, reproduction, adaptation or publication of this document in whole or in part and in any manner or form shall prominently contain this notice



AW189 Maintenance Review Board Report

189G0000M006

Issue V

Page 184 of 275

REVISION STATUS	MRB-R TASK NUMBER	TASK CODE	TASK TITLE	SOURCE	INTERVAL	SAMPLING	FEC	APPLICABILITY		ZONE	ACCESS & REMARKS
								AW189	AW189ER		
	731000M-02	GVI	GENERAL VISUAL INSPECTION OF ENGINE FUEL SYSTEM	MSI	400 FH	-	8	WITH CT7-2E1 ENGINE INSTALLATION	WITH CT7-2E1 ENGINE INSTALLATION	-	-
	731000M-03	DIS	DISCARD ENGINE FUEL FILTER ELEMENT	MSI	1600 FH	-	6	WITH CT7-2E1 ENGINE INSTALLATION	WITH CT7-2E1 ENGINE INSTALLATION	-	-
MSI 73-10-01: ENGINE FUEL DISTRIBUTION											
	731001M-01	FC	FUNCTIONAL CHECK OF ENGINE LOW PRESSURE PUMP OFF AIRCRAFT	MSI	3000 FH	-	6	WITH ANETO-1K ENGINE INSTALLATION	NO	-	-
	731001M-02	RST	RESTORATION (OVERHAUL) OF ENGINE ACCESSORY GEARBOX MODULE (M05) OFF AIRCRAFT NOTE: IDENTICAL TO 726001M-02	MSI	3000 FH	-	9	WITH ANETO-1K ENGINE INSTALLATION	NO	-	-
	731001M-03	RST	RESTORATION (OVERHAUL) OF HIGH PRESSURE PUMP AND METERING UNIT OFF AIRCRAFT	MSI	3000 FH	-	6; 8; 9	WITH ANETO-1K ENGINE INSTALLATION	NO	-	-

© Copyright 2024 Leonardo S.p.a.

This document contains information that is confidential and proprietary to Leonardo S.p.a. ('the Company') and is supplied on the express condition that it may not be disclosed to any third party, or reproduced in whole or in part, or used for manufacture, or used for any purpose other than for which it is supplied, without the prior written consent of the Company. Every permitted disclosure, reproduction, adaptation or publication of this document in whole or in part and in any manner or form shall prominently contain this notice



AW189 Maintenance Review Board Report

189G0000M006

Issue V

Page 185 of 275

REVISION STATUS	MRB-R TASK NUMBER	TASK CODE	TASK TITLE	SOURCE	INTERVAL	SAMPLING	FEC	APPLICABILITY		ZONE	ACCESS & REMARKS
								AW189	AW189ER		
	731001M-04	RST	RESTORATION (OVERHAUL) OF ENGINE HOT SECTION MODULE (M02) OFF AIRCRAFT NOTE: IDENTICAL TO 724001M-02	MSI	3000 FH	-	8	WITH ANETO-1K ENGINE INSTALLATION	NO	-	-
MSI 73-20-01: ENGINE CONTROLLING AND INDICATING EECU											
	732001M-01	FC	FUNCTIONAL CHECK OF FUEL PRESSURE-PRESSURE-TEMPERATURE SENSOR OFF AIRCRAFT	MSI	6000 FH	-	6	WITH ANETO-1K ENGINE INSTALLATION	NO	-	-
	732001M-02	FC	FUNCTIONAL CHECK OF OIL PRESSURE-PRESSURE-TEMPERATURE SENSOR OFF AIRCRAFT	MSI	6000 FH	-	6	WITH ANETO-1K ENGINE INSTALLATION	NO	-	-
	732001M-03	FC	FUNCTIONAL CHECK OF OIL PRESSURE-TEMPERATURE SENSOR OFF AIRCRAFT	MSI	6000 FH	-	6	WITH ANETO-1K ENGINE INSTALLATION	NO	-	-
ATA 74: IGNITION											
MSI 74-20-00: IGNITION DISTRIBUTION											

© Copyright 2024 Leonardo S.p.a.

This document contains information that is confidential and proprietary to Leonardo S.p.a. ('the Company') and is supplied on the express condition that it may not be disclosed to any third party, or reproduced in whole or in part, or used for manufacture, or used for any purpose other than for which it is supplied, without the prior written consent of the Company. Every permitted disclosure, reproduction, adaptation or publication of this document in whole or in part and in any manner or form shall prominently contain this notice



AW189 Maintenance Review Board Report

189G0000M006

Issue V

Page 186 of 275

REVISION STATUS	MRB-R TASK NUMBER	TASK CODE	TASK TITLE	SOURCE	INTERVAL	SAMPLING	FEC	APPLICABILITY		ZONE	ACCESS & REMARKS
								AW189	AW189ER		
	742000M-01	DI	DETAILED INSPECTION OF IGNITER PLUG NOTE: TO BE ACCOMPLISHED ON AN ALTERNATING BASIS (ONE IGNITER PLUG FROM EACH ENGINE AT EACH TASK EXECUTION)	MSI	200 FH	-	9	WITH CT7-2E1 ENGINE INSTALLATION	WITH CT7-2E1 ENGINE INSTALLATION	-	-
	742000M-02	DI	DETAILED INSPECTION OF IGNITION LEAD NOTE: TO BE ACCOMPLISHED ON AN ALTERNATING BASIS (ONE IGNITION LEAD FROM EACH ENGINE AT EACH TASK EXECUTION)	MSI	200 FH	-	9	WITH CT7-2E1 ENGINE INSTALLATION	WITH CT7-2E1 ENGINE INSTALLATION	-	-
MSI 74-20-01: IGNITION DISTRIBUTION											
	742001M-01	DI	DETAILED INSPECTION OF IGNITERS	MSI	800 FH	-	6	WITH ANETO-1K ENGINE INSTALLATION	NO	-	-

© Copyright 2024 Leonardo S.p.a.

This document contains information that is confidential and proprietary to Leonardo S.p.a. ('the Company') and is supplied on the express condition that it may not be disclosed to any third party, or reproduced in whole or in part, or used for manufacture, or used for any purpose other than for which it is supplied, without the prior written consent of the Company. Every permitted disclosure, reproduction, adaptation or publication of this document in whole or in part and in any manner or form shall prominently contain this notice



AW189 Maintenance Review Board Report

189G0000M006

Issue V

Page 187 of 275

REVISION STATUS	MRB-R TASK NUMBER	TASK CODE	TASK TITLE	SOURCE	INTERVAL	SAMPLING	FEC	APPLICABILITY		ZONE	ACCESS & REMARKS
								AW189	AW189ER		
	742001M-02	GVI	GENERAL VISUAL INSPECTION OF ENGINE (IGNITION CABLES) NOTE: SHOULD BE ACCOMPLISHED IN CONJUNCTION WITH 723001M-05, 723001M-06, 726001M-01, 726001M-03, 753001M-02 AND 755000M-01	MSI	50 FH	-	6	WITH ANETO-1K ENGINE INSTALLATION	NO	-	-
ATA 75: AIR											
MSI 75-10-00: ENGINE ANTI-ICING											
	751000M-01	OC	OPERATIONAL CHECK OF ENGINE ANTI-ICING SYSTEM	MSI	800 FH ; 1 YR	-	9	WITH CT7-2E1 ENGINE INSTALLATION	WITH CT7-2E1 ENGINE INSTALLATION	-	-
MSI 75-10-01: ENGINE ANTI-ICING											
	751001M-01	RST	RESTORATION (CLEANING) OF THE ENGINE ANTI-ICING VALVE FILTER OFF AIRCRAFT	MSI	800 FH; NOTE_B	-	6	WITH ANETO-1K ENGINE INSTALLATION	NO	-	-

© Copyright 2024 Leonardo S.p.a.

This document contains information that is confidential and proprietary to Leonardo S.p.a. ('the Company') and is supplied on the express condition that it may not be disclosed to any third party, or reproduced in whole or in part, or used for manufacture, or used for any purpose other than for which it is supplied, without the prior written consent of the Company. Every permitted disclosure, reproduction, adaptation or publication of this document in whole or in part and in any manner or form shall prominently contain this notice



AW189 Maintenance Review Board Report

189G0000M006

Issue V

Page 188 of 275

REVISION STATUS	MRB-R TASK NUMBER	TASK CODE	TASK TITLE	SOURCE	INTERVAL	SAMPLING	FEC	APPLICABILITY		ZONE	ACCESS & REMARKS
								AW189	AW189ER		
MSI 75-30-00: COMPRESSOR CONTROL											
	753000M-01	DI	DETAILED INSPECTION OF ENGINE VARIABLE GEOMETRY LINKAGE NOTE: COVERED BY 723000M-06	MSI	400 FH	-	6	WITH CT7-2E1 ENGINE INSTALLATION	WITH CT7-2E1 ENGINE INSTALLATION	-	-
MSI 75-30-01: COMPRESSOR CONTROL											
	753001M-01	RST	RESTORATION (CLEANING) OF THE ENGINE BLEED VALVE FILTER OFF AIRCRAFT	MSI	800 FH; NOTE_B	-	6	WITH ANETO-1K ENGINE INSTALLATION	NO	-	-
	753001M-02	GVI	GENERAL VISUAL INSPECTION OF ENGINE (VISIBLE PARTS OF INLET GUIDE-VANE/VARIABLE STATOR-VANE LINKAGE) NOTE: SHOULD BE ACCOMPLISHED IN CONJUNCTION WITH 723001M-05, 723001M-06, 726001M-01, 726001M-03, 742001M-02 AND 755000M-01.	MSI	50 FH	-	6	WITH ANETO-1K ENGINE INSTALLATION	NO	-	-

© Copyright 2024 Leonardo S.p.a.

This document contains information that is confidential and proprietary to Leonardo S.p.a. ('the Company') and is supplied on the express condition that it may not be disclosed to any third party, or reproduced in whole or in part, or used for manufacture, or used for any purpose other than for which it is supplied, without the prior written consent of the Company. Every permitted disclosure, reproduction, adaptation or publication of this document in whole or in part and in any manner or form shall prominently contain this notice



AW189 Maintenance Review Board Report

189G0000M006

Issue V

Page 189 of 275

REVISION STATUS	MRB-R TASK NUMBER	TASK CODE	TASK TITLE	SOURCE	INTERVAL	SAMPLING	FEC	APPLICABILITY		ZONE	ACCESS & REMARKS
								AW189	AW189ER		
MSI 75-50-00: INLET PARTICLE SEPERATOR											
	755000M-01	GVI	GENERAL VISUAL INSPECTION OF ENGINE PARTICLE SEPARATOR TRANSITION DUCT AND RECOVERY ASSEMBLY - (IF INSTALLED) NOTE: SHOULD BE ACCOMPLISHED IN CONJUNCTION WITH 723001M-05, 723001M-06, 726001M-01, 726001M-03, 753001M-02 AND 742001M-02	MSI	50 FH	-	9; 8	WITH ANETO-1K ENGINE INSTALLATION	NO	-	-
	755000M-02	DI	DETAILED INSPECTION OF THE INLET PARTICLE SEPARATOR FRONT DUCT, RECOVERY ASSEMBLY AND TRANSITION DUCT INTERVAL NOTE: 800FH REDUCED TO 200 FH IN CASE OF EROSION ENVIRONMENT	MSI	NOTE	-	9; 8	WITH ANETO-1K ENGINE INSTALLATION	NO	-	-

© Copyright 2024 Leonardo S.p.a.

This document contains information that is confidential and proprietary to Leonardo S.p.a. ('the Company') and is supplied on the express condition that it may not be disclosed to any third party, or reproduced in whole or in part, or used for manufacture, or used for any purpose other than for which it is supplied, without the prior written consent of the Company. Every permitted disclosure, reproduction, adaptation or publication of this document in whole or in part and in any manner or form shall prominently contain this notice



AW189 Maintenance Review Board Report

189G0000M006

Issue V

Page 190 of 275

REVISION STATUS	MRB-R TASK NUMBER	TASK CODE	TASK TITLE	SOURCE	INTERVAL	SAMPLING	FEC	APPLICABILITY		ZONE	ACCESS & REMARKS
								AW189	AW189ER		
	755000M-03	DIS	DISCARD METALLIC SEAL OF AIR INTAKE INNER DUCT OFF AIRCRAFT	MSI	NOTE_A	-	9	WITH ANETO-1K ENGINE INSTALLATION	NO	-	-
ATA 78: EXHAUST											
MSI 78-10-00: COLLECTOR / NOZZLE											
	781000M-01	DI	DETAILED INSPECTION OF CONED CENTRE BODY INCLUDING WELDS AND BOLTS	MSI	800 FH	-	6	WITH CT7-2E1 ENGINE INSTALLATION	WITH CT7-2E1 ENGINE INSTALLATION	-	-
	781000M-02	DI	DETAILED INSPECTION OF LOBED DIFFUSER INCLUDING WELDS & V-BAND CLAMP	MSI	800 FH	-	9	YES	YES	-	-
	781000M-03	DI	DETAILED INSPECTION OF EJECTOR NOZZLE INCLUDING WELDS, MOUNTINGS AND ATTACHMENT SCREWS	MSI	800 FH	-	9	YES	YES	-	-
ATA 79: OIL											
MSI 79-10-00: ENGINE LUBRICATION											

© Copyright 2024 Leonardo S.p.a.

This document contains information that is confidential and proprietary to Leonardo S.p.a. ('the Company') and is supplied on the express condition that it may not be disclosed to any third party, or reproduced in whole or in part, or used for manufacture, or used for any purpose other than for which it is supplied, without the prior written consent of the Company. Every permitted disclosure, reproduction, adaptation or publication of this document in whole or in part and in any manner or form shall prominently contain this notice



AW189 Maintenance Review Board Report

189G0000M006

Issue V

Page 191 of 275

REVISION STATUS	MRB-R TASK NUMBER	TASK CODE	TASK TITLE	SOURCE	INTERVAL	SAMPLING	FEC	APPLICABILITY		ZONE	ACCESS & REMARKS
								AW189	AW189ER		
	791000M-01	GVI	GENERAL VISUAL INSPECTION OF ENGINE OIL SYSTEM	MSI	400 FH	-	6	WITH CT7-2E1 ENGINE INSTALLATION	WITH CT7-2E1 ENGINE INSTALLATION	-	-
	791000M-02	DIS	DISCARD ENGINE OIL FILTER ELEMENT	MSI	1600 FH	-	6	WITH CT7-2E1 ENGINE INSTALLATION	WITH CT7-2E1 ENGINE INSTALLATION	-	-
MSI 79-10-01: ENGINE LUBRICATION											
	791001M-01	DIS	DISCARD ENGINE OIL FILTER ELEMENT	MSI	800 FH	-	6	WITH ANETO-1K ENGINE INSTALLATION	NO	-	-
	791001M-02	OC	OPERATIONAL CHECK OF THE ENGINE CHIP DETECTOR MAGNETIC PLUG	MSI	800 FH	-	9	WITH ANETO-1K ENGINE INSTALLATION	NO	-	-
	791001M-03	OC	OPERATIONAL CHECK OF THE OIL TANK CHIP DETECTOR MAGNETIC PLUG	MSI	800 FH	-	9	WITH ANETO-1K ENGINE INSTALLATION	NO	-	-
MSI 79-11-00: ENGINE DEBRIS WARNING SYSTEM											

© Copyright 2024 Leonardo S.p.a.

This document contains information that is confidential and proprietary to Leonardo S.p.a. ('the Company') and is supplied on the express condition that it may not be disclosed to any third party, or reproduced in whole or in part, or used for manufacture, or used for any purpose other than for which it is supplied, without the prior written consent of the Company. Every permitted disclosure, reproduction, adaptation or publication of this document in whole or in part and in any manner or form shall prominently contain this notice



AW189 Maintenance Review Board Report

189G0000M006

Issue V

Page 192 of 275

REVISION STATUS	MRB-R TASK NUMBER	TASK CODE	TASK TITLE	SOURCE	INTERVAL	SAMPLING	FEC	APPLICABILITY		ZONE	ACCESS & REMARKS
								AW189	AW189ER		
	791100M-01	OC	OPERATIONAL CHECK OF THE ENGINE CHIP DETECTOR SYSTEM NOTE: SHOULD BE PERFORMED AFTER 791001M-02 TASK ACCOMPLISHMENT	MSI	1600 FH ; 4 YR	-	9	WITH ANETO-1K ENGINE INSTALLATION	NO	-	-
ATA 93: SURVEILLANCE											
MSI 93-50-00: FORWARD LOOKING INFRA-RED SYSTEM KIT											
	935000M-01	SV	SERVICING (NITROGEN PURGE) OF THE FORWARD LOOKING INFRA-RED (FLIR) TURRET	MSI	1 MH; NOTE_B	-	9	WITH FLIR KIT	WITH FLIR KIT	-	-
	935000M-02	VC	VISUAL CHECK OF THE FORWARD LOOKING INFRA-RED (FLIR) TURRET DESICCANT CARTRIDGE INDICATOR	MSI	1 MH; NOTE_B	-	9	WITH FLIR KIT	WITH FLIR KIT	-	-
	935000M-03	DI	DETAILED INSPECTION OF THE FORWARD LOOKING INFRA-RED (FLIR) TURRET ATTACHMENT OFF AIRCRAFT	MSI	800 FH ; 1 YR	-	9	WITH FLIR KIT	WITH FLIR KIT	-	-

© Copyright 2024 Leonardo S.p.a.

This document contains information that is confidential and proprietary to Leonardo S.p.a. ('the Company') and is supplied on the express condition that it may not be disclosed to any third party, or reproduced in whole or in part, or used for manufacture, or used for any purpose other than for which it is supplied, without the prior written consent of the Company. Every permitted disclosure, reproduction, adaptation or publication of this document in whole or in part and in any manner or form shall prominently contain this notice



AW189 Maintenance Review Board Report

189G0000M006

Issue V

Page 193 of 275

REVISION STATUS	MRB-R TASK NUMBER	TASK CODE	TASK TITLE	SOURCE	INTERVAL	SAMPLING	FEC	APPLICABILITY		ZONE	ACCESS & REMARKS
								AW189	AW189ER		
MSI 93-50-01: LEONARDO ELECTRO OPTIC SURVEILLANCE SYSTEM											
	935001M-01	SV	SERVICING (NITROGEN PURGE) OF THE LEOSS TURRET	MSI	1 MH ; NOTE_B	-	9	with LEOSS Kit P/N 8G9350F00411	NO	-	-
	935001M-02	VC	VISUAL CHECK OF THE LEOSS TURRET DESICCANT CARTRIDGE INDICATOR	MSI	1 MH ; NOTE_B	-	9	with LEOSS Kit P/N 8G9350F00411	NO	-	-
	935001M-03	DI	DETAILED INSPECTION OF THE LEOSS TURRET ATTACHMENT OFF AIRCRAFT	MSI	800 FH / 1 YR	-	9	with LEOSS Kit P/N 8G9350F00411	NO	-	-
MSI 93-60-00: OBSTACLE PROXIMITY LIDAR SYSTEM											
	936000M-01	GVI	GENERAL VISUAL INSPECTION OF THE OBSTACLE PROXIMITY LIDAR SYSTEM SENSORS	MSI	400 FH	-	9	WITH OBSTACLE PROXIMITY LIDAR SYSTEM KIT	N/A	-	-
	936000M-02	FC	FUNCTIONAL CHECK (LASER ALIGNMENT) OF THE OBSTACLE PROXIMITY LIDAR SYSTEM	MSI	1600 FH	-	9	WITH OBSTACLE PROXIMITY LIDAR SYSTEM KIT	N/A	-	-
ATA 95: CREW ESCAPE AND SAFETY											

© Copyright 2024 Leonardo S.p.a.

This document contains information that is confidential and proprietary to Leonardo S.p.a. ('the Company') and is supplied on the express condition that it may not be disclosed to any third party, or reproduced in whole or in part, or used for manufacture, or used for any purpose other than for which it is supplied, without the prior written consent of the Company. Every permitted disclosure, reproduction, adaptation or publication of this document in whole or in part and in any manner or form shall prominently contain this notice



AW189 Maintenance Review Board Report

189G0000M006

Issue V

Page 194 of 275

REVISION STATUS	MRB-R TASK NUMBER	TASK CODE	TASK TITLE	SOURCE	INTERVAL	SAMPLING	FEC	APPLICABILITY		ZONE	ACCESS & REMARKS
								AW189	AW189ER		
MSI 95-40-00: WIRE STRIKE PROTECTION KIT											
	954000M-01	GVI	GENERAL VISUAL INSPECTION OF WIRE STRIKE PROTECTION COMPONENTS	MSI	2 YR	-	8	WITH WIRE STRIKE PROTECTION KIT(S)	WITH WIRE STRIKE PROTECTION KIT(S)	-	-
MSI 95-61-00: FLOTATION KIT											
	956100M-01	OC	OPERATIONAL CHECK OF THE EMERGENCY FLOTATION ACTIVATION SYSTEM	MSI	1 YR	-	8	WITH FLOTATION KIT	WITH FLOTATION KIT	-	-
R	956100M-02	FC	FUNCTIONAL CHECK (PRESSURE CHECK) OF INFLATION SYSTEM FLOATION BAGS OFF AIRCRAFT NOTE: SHOULD BE ACCOMPLISHED IN CONJUNCTION WITH 956100M-03	MSI	1 YR	-	8	WITH FLOTATION KIT	WITH FLOTATION KIT	-	-

© Copyright 2024 Leonardo S.p.a.

This document contains information that is confidential and proprietary to Leonardo S.p.a. ('the Company') and is supplied on the express condition that it may not be disclosed to any third party, or reproduced in whole or in part, or used for manufacture, or used for any purpose other than for which it is supplied, without the prior written consent of the Company. Every permitted disclosure, reproduction, adaptation or publication of this document in whole or in part and in any manner or form shall prominently contain this notice



AW189 Maintenance Review Board Report

189G0000M006

Issue V

Page 195 of 275

REVISION STATUS	MRB-R TASK NUMBER	TASK CODE	TASK TITLE	SOURCE	INTERVAL	SAMPLING	FEC	APPLICABILITY		ZONE	ACCESS & REMARKS
								AW189	AW189ER		
R	956100M-03	DI	DETAILED INSPECTION OF FLOAT INSTALLATION OFF AIRCRAFT NOTE: SHOULD BE ACCOMPLISHED IN CONJUNCTION WITH 956100M-02	MSI	1 YR	-	8	WITH FLOTATION KIT	WITH FLOTATION KIT	-	-
	956100M-04	RST	RESTORATION (OVERHAUL) OF THE FLOTATION INFLATION SYSTEM (2 OFF) OFF AIRCRAFT INTERVAL NOTE: 5 YR FROM MANUFACTURING OR LAST OVERHAUL OF THE CYLINDER	MSI	NOTE	-	8; 9	WITH FLOTATION KIT	WITH FLOTATION KIT	-	-
	956100M-05	-	TASK DELETED WITH MRBR ISSUE C	-	-	-	-	-	-	-	-

© Copyright 2024 Leonardo S.p.a.

This document contains information that is confidential and proprietary to Leonardo S.p.a. ('the Company') and is supplied on the express condition that it may not be disclosed to any third party, or reproduced in whole or in part, or used for manufacture, or used for any purpose other than for which it is supplied, without the prior written consent of the Company. Every permitted disclosure, reproduction, adaptation or publication of this document in whole or in part and in any manner or form shall prominently contain this notice



AW189 Maintenance Review Board Report

189G0000M006

Issue V

Page 196 of 275

REVISION STATUS	MRB-R TASK NUMBER	TASK CODE	TASK TITLE	SOURCE	INTERVAL	SAMPLING	FEC	APPLICABILITY		ZONE	ACCESS & REMARKS
								AW189	AW189ER		
	956100M-06	DIS	DISCARD PRESSURE VESSELS INTERVAL NOTE: 15 YR FROM MANUFACTURING	MSI	NOTE	-	8 ; 6	WITH FLOTATION KIT	WITH FLOTATION KIT	-	-
	956100M-07	-	TASK DELETED WITH MRBR ISSUE D	-	-	-	-	-	-	-	-
	956100M-08	OC	OPERATIONAL CHECK OF THE AUTOMATIC FLOTATION ACTIVATION SYSTEM	MSI	30 MH	-	8	WITH FLOTATION KIT	WITH FLOTATION KIT	-	-
	956100M-09	FC	FUNCTIONAL CHECK (PRESSURE CHECK) OF FLOTATION GAS DISTRIBUTION NETWORK NOTE: SHOULD BE ACCOMPLISHED IN CONJUNCTION WITH 956100M-04	MSI	5 YR	-	8	WITH FLOTATION KIT	WITH FLOTATION KIT	-	-
MSI 95-62-00: LIFE RAFT AND LIFE JACKETS KITS											
	956200M-01	OC	OPERATIONAL CHECK OF THE PILOT / CO-PILOT LIFE RAFT CABLES	MSI	1 YR	-	8	WITH LIFE RAFT KIT	WITH LIFE RAFT KIT	-	-

© Copyright 2024 Leonardo S.p.a.

This document contains information that is confidential and proprietary to Leonardo S.p.a. ('the Company') and is supplied on the express condition that it may not be disclosed to any third party, or reproduced in whole or in part, or used for manufacture, or used for any purpose other than for which it is supplied, without the prior written consent of the Company. Every permitted disclosure, reproduction, adaptation or publication of this document in whole or in part and in any manner or form shall prominently contain this notice



AW189 Maintenance Review Board Report

189G0000M006

Issue V

Page 197 of 275

REVISION STATUS	MRB-R TASK NUMBER	TASK CODE	TASK TITLE	SOURCE	INTERVAL	SAMPLING	FEC	APPLICABILITY		ZONE	ACCESS & REMARKS
								AW189	AW189ER		
	956200M-02	DI	<p>DETAILED INSPECTION OF LIFE RAFT FOR INTEGRITY AND CONDITION</p> <p>OFF AIRCRAFT</p> <p>INTERVAL NOTE: THE TASK MUST BE PERFORMED EVERY 1 YR FROM THE INSTALLATION DATE. THIS IS THE DATE THE ASSEMBLY WAS INSTALLED ON THE AIRCRAFT EITHER FROM NEW OR FROM THE LAST DETAILED INSPECTION.</p> <p>NOTE: SHOULD BE ACCOMPLISHED IN CONJUNCTION WITH 956200M-12</p>	MSI	NOTE	-	8	WITH LIFE RAFT KIT	WITH LIFE RAFT KIT	-	-

© Copyright 2024 Leonardo S.p.a.

This document contains information that is confidential and proprietary to Leonardo S.p.a. ('the Company') and is supplied on the express condition that it may not be disclosed to any third party, or reproduced in whole or in part, or used for manufacture, or used for any purpose other than for which it is supplied, without the prior written consent of the Company. Every permitted disclosure, reproduction, adaptation or publication of this document in whole or in part and in any manner or form shall prominently contain this notice



AW189 Maintenance Review Board Report

189G0000M006

Issue V

Page 198 of 275

REVISION STATUS	MRB-R TASK NUMBER	TASK CODE	TASK TITLE	SOURCE	INTERVAL	SAMPLING	FEC	APPLICABILITY		ZONE	ACCESS & REMARKS
								AW189	AW189ER		
	956200M-03	FC	FUNCTIONAL CHECK (PRESSURE CHECK) OF LIFE RAFT OFF AIRCRAFT INTERVAL NOTE: 30MH FROM MANUFACTURING OR LAST FUNCTIONAL CHECK NOTE 2: SHOULD BE ACCOMPLISHED IN CONJUNCTION WITH 956200M-05 AND, 956200M-09	MSI	NOTE	-	8	WITH LIFE RAFT KIT	WITH LIFE RAFT KIT	-	-
	956200M-04	DIS	DISCARD LIFE RAFT SURVIVAL KIT LIFE LIMITED ITEMS INTERVAL NOTE: EXPIRY DATE REPORTED IN THE LIFE RAFT TAG	MSI	NOTE	-	8	WITH LIFE RAFT KIT	WITH LIFE RAFT KIT	-	-

© Copyright 2024 Leonardo S.p.a.

This document contains information that is confidential and proprietary to Leonardo S.p.a. ('the Company') and is supplied on the express condition that it may not be disclosed to any third party, or reproduced in whole or in part, or used for manufacture, or used for any purpose other than for which it is supplied, without the prior written consent of the Company. Every permitted disclosure, reproduction, adaptation or publication of this document in whole or in part and in any manner or form shall prominently contain this notice



AW189 Maintenance Review Board Report

189G0000M006

Issue V

Page 199 of 275

REVISION STATUS	MRB-R TASK NUMBER	TASK CODE	TASK TITLE	SOURCE	INTERVAL	SAMPLING	FEC	APPLICABILITY		ZONE	ACCESS & REMARKS
								AW189	AW189ER		
	956200M-05	DI	DETAILED INSPECTION OF LIFE RAFT SURVIVAL KIT INTERVAL NOTE: 30MH FROM MANUFACTURING OR LAST DETAILED INSPECTION NOTE: SHOULD BE ACCOMPLISHED IN CONJUNCTION WITH 956200M-03 AND 956200M-09	MSI	NOTE	-	8	WITH LIFE RAFT KIT	WITH LIFE RAFT KIT	-	-
	956200M-06	RST	RESTORATION (OVERHAUL) OF LIFE JACKET INTERVAL NOTE: 10 YR FROM MANUFACTURING OR FROM LAST OVERHAUL OFF AIRCRAFT	MSI	NOTE	-	8	WITH LIFE JACKET KITS	WITH LIFE JACKET KITS	-	-
	956200M-07	DI	DETAILED INSPECTION OF LIFE JACKET PACKAGE	MSI	1 YR	-	8	WITH LIFE JACKET KITS	WITH LIFE JACKET KITS	-	-

© Copyright 2024 Leonardo S.p.a.

This document contains information that is confidential and proprietary to Leonardo S.p.a. ('the Company') and is supplied on the express condition that it may not be disclosed to any third party, or reproduced in whole or in part, or used for manufacture, or used for any purpose other than for which it is supplied, without the prior written consent of the Company. Every permitted disclosure, reproduction, adaptation or publication of this document in whole or in part and in any manner or form shall prominently contain this notice



AW189 Maintenance Review Board Report

189G0000M006

Issue V

Page 200 of 275

REVISION STATUS	MRB-R TASK NUMBER	TASK CODE	TASK TITLE	SOURCE	INTERVAL	SAMPLING	FEC	APPLICABILITY		ZONE	ACCESS & REMARKS
								AW189	AW189ER		
	956200M-08	RST	RESTORATION (OVERHAUL) OF LIFE RAFT INFLATION ASSEMBLY OFF AIRCRAFT INTERVAL NOTE: 5 YR FROM MANUFACTURING OR FROM LAST OVERHAUL	MSI	NOTE	-	8	WITH LIFE RAFT KIT	WITH LIFE RAFT KIT	-	-
	956200M-09	OC	OPERATIONAL CHECK OF LIFE RAFT LIGHT SYSTEM OFF AIRCRAFT INTERVAL NOTE: 30MH FROM MANUFACTURING OR LAST OPERATIONAL CHECK NOTE: SHOULD BE ACCOMPLISHED IN CONJUNCTION WITH 956200M-03 AND 956200M- 05	MSI	NOTE	-	8	WITH LIFE RAFT KIT	WITH LIFE RAFT KIT	-	-

© Copyright 2024 Leonardo S.p.a.

This document contains information that is confidential and proprietary to Leonardo S.p.a. ('the Company') and is supplied on the express condition that it may not be disclosed to any third party, or reproduced in whole or in part, or used for manufacture, or used for any purpose other than for which it is supplied, without the prior written consent of the Company. Every permitted disclosure, reproduction, adaptation or publication of this document in whole or in part and in any manner or form shall prominently contain this notice



AW189 Maintenance Review Board Report

189G0000M006

Issue V

Page 201 of 275

REVISION STATUS	MRB-R TASK NUMBER	TASK CODE	TASK TITLE	SOURCE	INTERVAL	SAMPLING	FEC	APPLICABILITY		ZONE	ACCESS & REMARKS
								AW189	AW189ER		
	956200M-10	DIS	DISCARD LIFE RAFT ELT BATTERY PACK INTERVAL NOTE: 5 YR FROM MANUFACTURING	MSI	NOTE	-	8	WITH LIFE RAFT KIT	WITH LIFE RAFT KIT	-	-
	956200M-11	DIS	DISCARD LIFE RAFT INFLATION SYSTEM CYLINDER INTERVAL NOTE: 15 YR FROM MANUFACTURING	MSI	NOTE	-	8	WITH LIFE RAFT KIT	WITH LIFE RAFT KIT	-	-
	956200M-12	OC	OPERATIONAL CHECK OF LIFERAFT EMERGENCY LOCATOR TRANSMITTER. OFF AIRCRAFT NOTE: SHOULD BE ACCOMPLISHED IN CONJUNCTION WITH , 956200M-02	MSI	1 YR	-	8	WITH LIFE RAFT KIT	WITH LIFE RAFT KIT	-	-
	956200M-13	DIS	DISCARD LIFERAFT LIGHT BATTERY PACK INTERVAL NOTE: 5 YR FROM MANUFACTURING	MSI	NOTE	-	8	WITH LIFE RAFT KIT	WITH LIFE RAFT KIT	-	-

© Copyright 2024 Leonardo S.p.a.

This document contains information that is confidential and proprietary to Leonardo S.p.a. ('the Company') and is supplied on the express condition that it may not be disclosed to any third party, or reproduced in whole or in part, or used for manufacture, or used for any purpose other than for which it is supplied, without the prior written consent of the Company. Every permitted disclosure, reproduction, adaptation or publication of this document in whole or in part and in any manner or form shall prominently contain this notice



AW189 Maintenance Review Board Report

189G0000M006

Issue V

Page 202 of 275

REVISION STATUS	MRB-R TASK NUMBER	TASK CODE	TASK TITLE	SOURCE	INTERVAL	SAMPLING	FEC	APPLICABILITY		ZONE	ACCESS & REMARKS
								AW189	AW189ER		
MSI 95-63-00: COMBINED EMERGENCY FLOTATION SYSTEM											
N	956300M-01	OC	OPERATIONAL CHECK OF THE FLOTATION MANUAL ACTIVATION SYSTEM	MSI	2 YR	-	8	WITH DART FLOTATION KIT	WITH DART FLOTATION KIT	160 100	163A, 164A, 166A
N	956300M-02	OC	OPERATIONAL CHECK OF THE FLOTATION AUTOMATIC ACTIVATION SYSTEM	MSI	2 YR	-	8	WITH DART FLOTATION KIT	WITH DART FLOTATION KIT	160 100	163A, 164A, 166A
N	956300M-03	RST	RESTORATION (OVERHAUL) OF THE FLOTATION INFLATION SYSTEM. (OFF AIRCRAFT) INTERVAL NOTE: 4 YR OR 60 MH FROM MANUFACTURING	MSI	NOTE	-	6; 9; 8	WITH DART FLOTATION KIT	WITH DART FLOTATION KIT	100	163A, 164A, 126A, 121A
N	956300M-04	DIS	DISCARD FLOTATION INFLATION SYSTEM PRESSURE VESSEL INTERVAL NOTE: 15 YR FROM MANUFACTURING	MSI	NOTE	-	6	WITH DART FLOTATION KIT	WITH DART FLOTATION KIT	160	163A, 164A

© Copyright 2024 Leonardo S.p.a.

This document contains information that is confidential and proprietary to Leonardo S.p.a. ('the Company') and is supplied on the express condition that it may not be disclosed to any third party, or reproduced in whole or in part, or used for manufacture, or used for any purpose other than for which it is supplied, without the prior written consent of the Company. Every permitted disclosure, reproduction, adaptation or publication of this document in whole or in part and in any manner or form shall prominently contain this notice



AW189 Maintenance Review Board Report

189G0000M006

Issue V

Page 203 of 275

REVISION STATUS	MRB-R TASK NUMBER	TASK CODE	TASK TITLE	SOURCE	INTERVAL	SAMPLING	FEC	APPLICABILITY		ZONE	ACCESS & REMARKS
								AW189	AW189ER		
N	956300M-05	DIS	DISCARD LIFERAFT INFLATION SYSTEM PRESSURE VESSEL INTERVAL NOTE: 15 YR FROM MANUFACTURING	MSI	NOTE	-	6	WITH DART FLOTATION W/ LIFERAFT KIT	WITH DART FLOTATION W/ LIFERAFT KIT	160	167A
N	956300M-06	DI	DETAILED INSPECTION OF FLOATS INSTALLATION (OFF AIRCRAFT) NOTE: SHOULD BE ACCOMPLISHED IN CONJUNCTION WITH 956300M-15	MSI	2 YR	-	8; 9	WITH DART FLOTATION KIT	WITH DART FLOTATION KIT	100	163A, 164A, 126A, 121A
N	956300M-07	DI	DETAILED INSPECTION OF LIFERAFT INSTALLATION (OFF AIRCRAFT) NOTE: SHOULD BE ACCOMPLISHED IN CONJUNCTION WITH 956300M-06, 956300M-12, 956300M-15 AND 956300M-16	MSI	2 YR	-	8; 9	WITH DART FLOTATION W/ LIFERAFT KIT	WITH DART FLOTATION W/ LIFERAFT KIT	160	163A, 164A

© Copyright 2024 Leonardo S.p.a.

This document contains information that is confidential and proprietary to Leonardo S.p.a. ("the Company") and is supplied on the express condition that it may not be disclosed to any third party, or reproduced in whole or in part, or used for manufacture, or used for any purpose other than for which it is supplied, without the prior written consent of the Company. Every permitted disclosure, reproduction, adaptation or publication of this document in whole or in part and in any manner or form shall prominently contain this notice



AW189 Maintenance Review Board Report

189G0000M006

Issue V

Page 204 of 275

REVISION STATUS	MRB-R TASK NUMBER	TASK CODE	TASK TITLE	SOURCE	INTERVAL	SAMPLING	FEC	APPLICABILITY		ZONE	ACCESS & REMARKS
								AW189	AW189ER		
N	956300M-08	FC	FUNCTIONAL CHECK (PRESSURE CHECK) OF FLOTATION GAS DISTRIBUTION NOTE: SHOULD BE PERFORMED FOLLOWING REMOVAL OF FLOTATION INFLATION ASSEMBLY FOR RESTORATION.	MSI	60 MH	-	8	WITH DART FLOTATION KIT	WITH DART FLOTATION KIT	100 160	121A,126A, '163A, 164A, 166A
N	956300M-09	FC	FUNCTIONAL CHECK (PRESSURE CHECK) OF LIFERAFT GAS DISTRIBUTION NOTE: SHOULD BE PERFORMED FOLLOWING REMOVAL OF LIFERAFT INFLATION ASSEMBLY FOR RESTORATION.	MSI	60 MH	-	8	WITH DART FLOTATION W/ LIFERAFT KIT	WITH DART FLOTATION W/ LIFERAFT KIT	100 160	163A, 164A, 166A
N	956300M-10	OC	OPERATIONAL CHECK (FREEDOM OF MOVEMENT) OF LIFERAFT MANUAL RELEASE	MSI	2 YR	-	8	WITH DART FLOTATION W/ LIFERAFT KIT	WITH DART FLOTATION W/ LIFERAFT KIT	210 200	COKCPIT DOORS AND EXTERNAL

© Copyright 2024 Leonardo S.p.a.

This document contains information that is confidential and proprietary to Leonardo S.p.a. ('the Company') and is supplied on the express condition that it may not be disclosed to any third party, or reproduced in whole or in part, or used for manufacture, or used for any purpose other than for which it is supplied, without the prior written consent of the Company. Every permitted disclosure, reproduction, adaptation or publication of this document in whole or in part and in any manner or form shall prominently contain this notice



AW189 Maintenance Review Board Report

189G0000M006

Issue V

Page 205 of 275

REVISION STATUS	MRB-R TASK NUMBER	TASK CODE	TASK TITLE	SOURCE	INTERVAL	SAMPLING	FEC	APPLICABILITY		ZONE	ACCESS & REMARKS
								AW189	AW189ER		
N	956300M-11	RST	RESTORATION (OVERHAUL) OF THE LIFERAFT INFLATION SYSTEM. (OFF AIRCRAFT) INTERVAL NOTE: 4 YR OR 60 MH FROM MANUFACTURING	MSI	NOTE	-	8; 6; 9	WITH DART FLOTATION W/ LIFERAFT KIT	WITH DART FLOTATION W/ LIFERAFT KIT	160	167A
N	956300M-12	OC	OPERATIONAL CHECK OF LIFERAFT SEA LIGHT SYSTEM. (OFF AIRCRAFT) NOTE: SHOULD BE ACCOMPLISHED IN CONJUNCTION WITH 956300M-06, 956300M-07, 956300M-15 AND 956300M-16	MSI	2 YR	-	8	WITH DART FLOTATION W/ LIFERAFT KIT	WITH DART FLOTATION W/ LIFERAFT KIT	160	163A, 164A
N	956300M-13	OC	OPERATIONAL CHECK OF LIFERAFT EMERGENCY LOCATOR TRANSMITTER. (OFF AIRCRAFT)	MSI	2 YR	-	8	WITH DART FLOTATION W/ LIFERAFT KIT	WITH DART FLOTATION W/ LIFERAFT KIT	100	AFT FLOAT & RAFT POD ELT POCKET COVER

© Copyright 2024 Leonardo S.p.a.

This document contains information that is confidential and proprietary to Leonardo S.p.a. ('the Company') and is supplied on the express condition that it may not be disclosed to any third party, or reproduced in whole or in part, or used for manufacture, or used for any purpose other than for which it is supplied, without the prior written consent of the Company. Every permitted disclosure, reproduction, adaptation or publication of this document in whole or in part and in any manner or form shall prominently contain this notice



AW189 Maintenance Review Board Report

189G0000M006

Issue V

Page 206 of 275

REVISION STATUS	MRB-R TASK NUMBER	TASK CODE	TASK TITLE	SOURCE	INTERVAL	SAMPLING	FEC	APPLICABILITY		ZONE	ACCESS & REMARKS
								AW189	AW189ER		
N	956300M-14	DIS	DISCARD LIFERAFT EMERGENCY LOCATION TRANSMITTER BATTERY PACK. INTERVAL NOTE: 4 YR OR DATE OF EXPIRY ON BATTERY	MSI	NOTE	-	8	WITH DART FLOTATION W/ LIFERAFT KIT	WITH DART FLOTATION W/ LIFERAFT KIT	100	AFT FLOAT & RAFT POD ELT POCKET COVER
N	956300M-15	FC	FUNCTIONAL CHECK (PRESSURE CHECK) OF FLOTATION BAGS OFF AIRCRAFT (OFF AIRCRAFT) NOTE: SHOULD BE ACCOMPLISHED IN CONJUNCTION WITH 956300M-06.	MSI	2 YR	-	8	WITH DART FLOTATION KIT	WITH DART FLOTATION KIT	100 160	121A,126A, '163A, 164A, 166A

© Copyright 2024 Leonardo S.p.a.

This document contains information that is confidential and proprietary to Leonardo S.p.a. ('the Company') and is supplied on the express condition that it may not be disclosed to any third party, or reproduced in whole or in part, or used for manufacture, or used for any purpose other than for which it is supplied, without the prior written consent of the Company. Every permitted disclosure, reproduction, adaptation or publication of this document in whole or in part and in any manner or form shall prominently contain this notice



AW189 Maintenance Review Board Report

189G0000M006

Issue V

Page 207 of 275

REVISION STATUS	MRB-R TASK NUMBER	TASK CODE	TASK TITLE	SOURCE	INTERVAL	SAMPLING	FEC	APPLICABILITY		ZONE	ACCESS & REMARKS
								AW189	AW189ER		
N	956300M-16	FC	FUNCTIONAL CHECK (PRESSURE CHECK) OF LIFERAFT (OFF AIRCRAFT) NOTE: SHOULD BE ACCOMPLISHED IN CONJUNCTION WITH 956300M-06, 956300M-07, 956300M-12 AND 956300M-15	MSI	2 YR	-	9	WITH DART FLOTATION W/ LIFERAFT KIT	WITH DART FLOTATION W/ LIFERAFT KIT	160	163A, 164A

© Copyright 2024 Leonardo S.p.a.

This document contains information that is confidential and proprietary to Leonardo S.p.a. ('the Company') and is supplied on the express condition that it may not be disclosed to any third party, or reproduced in whole or in part, or used for manufacture, or used for any purpose other than for which it is supplied, without the prior written consent of the Company. Every permitted disclosure, reproduction, adaptation or publication of this document in whole or in part and in any manner or form shall prominently contain this notice



SECTION D - STRUCTURE

1. GENERAL

The primary objective of structural inspections is to maintain the inherent airworthiness throughout the operational life of the rotorcraft in an economical manner.

The inspections are developed to meet the detection requirements from the Accidental Damage (AD), Environmental Deterioration (ED) assessments and must also meet the requirements for Corrosion Prevention and Control Programme (CPCP) to maintain rotorcraft at Level 1 Corrosion or better.

The structural inspections are based on an assessment of structural design, the environment in which the structure is located, the protective treatments that the structure has been subjected to, service experience with similar designs and pertinent test results.

This section covers all Structural Significant Items (SSIs) as listed in [Appendix 6](#) of this report.

These requirements include external and internal inspections plus corrosion prevention and control programmes.

Structural inspection maintenance requirement information provided in this section is presented in sequence / order by ATA Chapter assigned subject numbers.



2. ROTORCRAFT STRUCTURE CLASSIFICATION

Rotorcraft structure consists of:

- Wings (e.g. Horizontal Stabiliser/tail plane) ;
- Fuselage;
- Empennage;
- engine / transmission mountings;
- landing gear;
- non-rotating flight control surfaces and related points of attachment.

The actuating functions of items such as landing gear, non-rotating flight controls, doors, and the fixed flight controls (if rotor servo-actuators isolate them from the external loads) have been addressed in the System and Powerplant analysis.

The attachment fittings of the actuators to the airframe have been treated as structure, while the system related functions of items such as hinge bearings have been addressed in the System and Powerplant analysis.

Structure-to-structure attachment points, not otherwise associated with a rotorcraft system (e.g., pylon attach fittings and diagonal braces), that feature bearings have been treated as structure.

Items within the ATA Chapters 62, 63 (excluding transmission mountings), 64 and 65 (excluding transmission mountings) are not considered as parts of rotorcraft structure but as part of Rotors / Drive Systems.

Structure can be subdivided into items according to the consequences of their failure to rotorcraft safety as follows:

- (a) A “Structural Significant Item (SSI)” is any detail, element or assembly, which contributes significantly to carrying flight, ground, pressure or control loads, and whose failure could affect the structural integrity necessary for the safety of the rotorcraft. For the purpose of the AW189 MRB Process, structural element or assembly whose failure may lead to significant reduction of the rotorcraft control capability are also considered SSI.



NOTE: SSIs must not be confused with Principal Structural Elements (PSE in accordance with Airworthiness Regulations, e.g. CS 29.571, 14 CFR § 29.571, etc.); however, all PSE's must be addressed by the SSI's.

(b) "Other Structure" is that which is judged not to be a Structural Significant Item. It is defined both externally and internally within zonal boundaries.

NOTE: When assemblies are selected to be SSI, those elements that form the assembly and comply with the SSI definition have been included (e.g., single bolt attaching a pylon diagonal brace).



3. STRUCTURE SECTION RULES

All aircraft in an Operator's or group of Operator's fleet shall be subject to the provisions of this Report. These requirements include external and internal inspections, corrosion prevention and control programme, and additional structural inspections that may be required through the Simplified Fatigue Analysis for metallic SSI not classified as PSE.

- 1) In this Section, three inspection levels are used as follows:
 - General Visual Inspection (GVI)
 - Detailed Inspection (DI)
 - Special Detailed Inspection (SDI)

For definition of these inspection levels refer to GLOSSARY, [Appendix 4](#).

- 2) Proper attention must be paid to the intended level of inspection (general visual, detailed or special detailed), and all inspections are to be carried out with equal attention paid to all possible types of damage. For example, a detailed inspection for accidental damage must also take into account possible corrosion.
- 3) The intention of an MRB Report structure inspection maintenance task for the AW189 rotorcraft is to inspect the specified area to the intended level of inspection (GVI, DI or SDI) for any sign of structural degradation, such as: dents, scratches, paint discoloration, any sign of corrosion, etc.
- 4) Inspection of standard bolt(s) (either GVI or DI) may be replaced with a discard of the bolt(s) at the same interval.
- 5) All SSI as listed in [Appendix 6](#) of this report have been subjected to the MSG-3 analysis; this process has resulted in the identification of maintenance tasks which are contained in this section.

Those SSIs for which a task was not generated during the analysis are identified in [Appendix 6](#).



- 6) Information related to the removal/application of the corrosion protection compound, when applicable, will be provided directly in the relevant maintenance task procedure in the AMPI.



4. CORROSION PREVENTION AND CONTROL PROGRAMME

4.1 BACKGROUND

Satisfactory rotorcraft corrosion prevention is the result of activities performed during design phase, production phase and rotorcraft operative phases.

- In design phase, the corrosion resistance requirements have to be consistent with the typical environmental of the rotorcraft activity. Adequate materials, treatments and protection finishes must be chosen by the designer and contact between dissimilar materials should be avoided, as far as practicable.
- In production phase, the production processes have to minimise the time during which rotorcraft components are unprotected and adequate protection methods have to be used during the storage of the components.
- In operative phase, an adequate preventive maintenance activity can maintain the inherent level of corrosion resistance and outline if some improvement is necessary. This is the scope of CPCP information provided in this report.

4.2 MANUFACTURER BASELINE CPCP

The manufacturer baseline CPCP is established by LHs to allow control of the corrosion on rotorcraft to Level 1 or better, refer to [Appendix 4](#) for Corrosion Level definitions.

The baseline CPCP is based on the Environmental Deterioration (ED) analysis assuming that rotorcraft is operated in a typical environment.

Consequently the maintenance requirement derived by Environmental Deterioration analysis are the minimal actions to be performed in corrosion control activity and associated CPCP tasks are identified within the sections C and D of this report by using “CPCP” marker in the source column.

This manufacturer baseline CPCP is the basis from which operators develop their own Operator CPCP (refer to EASA AMC 20-20 or equivalent).



The manufacturer will periodically review all the CPCP findings level 2 or 3 reported by operators and will adjust the manufacturer baseline CPCP related scheduled maintenance requirements accordingly.

4.3 OPERATOR CPCP

Operator must establish their own CPCP on the basis of the manufacturer baseline CPCP and adjust it on the basis of their own in service experience.

With reference to those tasks identified with “CPCP” marker, the following rules related to “Corrosion Findings” are applicable to Operators:

- Level 1 Corrosion Findings

If in-service findings data reveal corrosion level 1 or better, the existing interval is considered effective.

The Operator is requested to report this occurrence to Leonardo Helicopters.

Operators might report corrosion level 1 or better providing the information specified within [Appendix 8](#). Any other preferred means, lay-out or template are acceptable.

- Level 2 or 3 Corrosion Findings

If corrosion is found to exceed Level 1 at any inspection time, the Operator must report this occurrence to Leonardo Helicopters and the National Aviation Authority to agree on the corrective action and the corrosion prevention control programme for the affected area must be revised by the Operator with the objective to ensure Corrosion Level 1 or better.

Operators must report corrosion level 2 and 3 findings providing the information specified within [Appendix 8](#) in a timely manner.



5. EXPLANATION OF STRUCTURE SECTION FORMAT

Detailed information concerning the format of the inspection requirements is presented in Table 4.

REV STATUS	MRB-R TASK REF	TASK CODE	TASK TITLE	SOURCE	INTERVAL	APPLICABILITY	ZONE	ACCESS & REMARKS
1	2	3	4	5	6	7	8	9

TABLE 3

1 – This column shows the revision status of each single Task Reference as follows:

- N – New Item
- R – Revised Item
- D – Deleted Item
- “ _ ” (blank) – Unchanged Item

In the initial MRB Report this column will be blank. Revision status references will be added on subsequent revisions.

2 – This column indicates the SSI task reference, e.g. 561115S-01. It is composed of 10 symbols as follows:

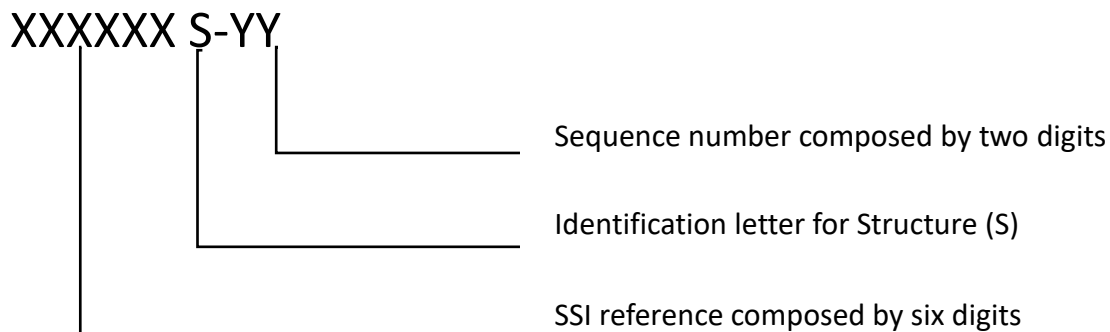

The SSI reference represented by six digits is obtained from the SSI selection procedure defined in PPH.



3 – This column identifies the task code assigned during the structural analysis, here below the used codes:

GVI: General Visual Inspection

DI: Detailed Inspection

SDI: Special Detailed Inspection

4 – This column identifies the SSI title and the description of each task identified through the MSG3 Analysis process.

If the wording “NOTE” is used in other columns its explanation is reported in this column.

The meaning of MRBR Interval notes, such as NOTE_B, is provided in section B.

5 - This column specifies the source for task selection, following codes are used:

○ AD, for tasks resulting from accidental damage (AD) analysis

○ ED, for tasks resulting from environmental deterioration (ED) and fretting corrosion analysis

○ CPCP, for tasks resulting from Corrosion Prevention Control Programme

Multiple sources are referred to when applicable.

6 – This column specifies the task repeat intervals in terms of Rotorcraft Flight Hours (FH), Rotorcraft Landing (RL) or Calendar Time as applicable.

The Threshold Inspection interval is set equal to the repeat interval.

The Calendar Time is represented by means of following measure units:

- DY = Days

- MH = Months

- YR = Years.

The calendar interval is expressed using the highest available measure unit, for example:

- 12 MO is indicated as 1 YR

- 18 MO remains unchanged.



Whenever more than one usage parameter interval is assigned to a task, and when not stated otherwise, the interval expiring first shall apply

7 – Applicability information is presented in 2 sub-columns, one for the AW189 and the other for AW189ER (for definition refer to Section A Para 1.1)

These applicability columns indicate the rotorcraft type and modification status, as necessary, to which the task is applicable.

Here after some examples of applicability information which might be provided for each sub-column:

- “YES”
- “NO”
- “with Rotor Brake kit ”;
- “S/N from xxxx to xxxx
- “post SB xxxx”
- “with CT7-2E1 engine installation”
- “with Aneto-1K engine installation”
- Others as applicable

8 – This column indicates the zone(s) where the SSI is located. For the zone boundaries refer to Rotorcraft Zones and Access, [Appendix 2](#).

Multiple zones are reported when applicable.

9 – This column reports information about access or removal requirements.

“EXTERNAL” stated only when no other access stated; however during the inspection/task, external/direct access may always be applicable.



6. LIST OF TASK

REVISION STATUS	MRB-R TASK NUMBER	TASK CODE	TASK TITLE	SOURCE	INTERVAL	APPLICABILITY		ZONE	ACCESS & REMARKS
						AW189	AW189ER		
ATA 18: VIBRATION AND NOISE ANALYSIS AND ATTENUATION									
SSI 18-60-02: RH VIBRATION PASSIVE ATTENUATION ASSY									
	186002S-01	-	TASK DELETED WITH MRBR ISSUE O	-	-	-	-	-	-
	186002S-02	-	TASK DELETED WITH MRBR ISSUE O	-	-	-	-	-	-
ATA 25: EQUIPMENT / FURNISHINGS									
SSI 25-90-02 / 03: HARD POINTS RING ASSY / CABIN REINFORCEMENTS									
	259002S-01	DI	DETAILED INSPECTION OF THE HARD POINTS RING ASSY (VISIBLE PARTS) AND ANCHOR BOLTS (BOLTS REMOVED)	ED ; CPCP	4 YR	WITH CABIN REINFORCED HARD POINTS KIT	WITH CABIN REINFORCED HARD POINTS KIT	220	ACCESS: PASSENGER DOOR
SSI 25-91-01: SINGLE HOIST STRUCTURAL SUPPORT ASSY									
	259101S-01	DI	DETAILED INSPECTION OF THE HOIST STRUCTURAL SUPPORT INTERFACE DEVICES	ED ; CPCP	8 YR	WITH SINGLE RESCUE HOIST KIT	WITH SINGLE RESCUE HOIST KIT	180	ACCESS: EXTERNAL

© Copyright 2024 Leonardo S.p.a.

This document contains information that is confidential and proprietary to Leonardo S.p.a. ('the Company') and is supplied on the express condition that it may not be disclosed to any third party, or reproduced in whole or in part, or used for manufacture, or used for any purpose other than for which it is supplied, without the prior written consent of the Company. Every permitted disclosure, reproduction, adaptation or publication of this document in whole or in part and in any manner or form shall prominently contain this notice



AW189 Maintenance Review Board Report

189G0000M006

Issue V

Page 219 of 275

REVISION STATUS	MRB-R TASK NUMBER	TASK CODE	TASK TITLE	SOURCE	INTERVAL	APPLICABILITY		ZONE	ACCESS & REMARKS
						AW189	AW189ER		
	259101S-02	DI	DETAILED INSPECTION OF THE FOLLOWING FIT BOLTS: - THE BOLTS JOINING THE HOIST TUBE CLAMPS TO THE HOIST MOUNT ASSY. - THE BOLTS JOINING THE HOIST TUBE CLAMPS TO THE SINGLE HOIST TUBE ATTACHMENT NOTE: TO BE ACCOMPLISHED IN CONJUNCTION WITH 259101S-04	ED ; CPCP	8 YR	WITH SINGLE RESCUE HOIST KIT	WITH SINGLE RESCUE HOIST KIT	180	ACCESS: EXTERNAL REMOVAL: FIT BOLTS
	259101S-03	DI	DETAILED INSPECTION OF THE FOLLOWING FIT BOLTS: - THE BOLTS JOINING THE RESCUE HOIST TO THE SINGLE HOIST TUBE ATTACHMENT BRACKETS. - THE BOLTS JOIN THE HOIST MOUNT ASSY TO THE FUSELAGE MOUNTING PLATE ASSY	ED ; CPCP	2 YR	WITH SINGLE RESCUE HOIST KIT	WITH SINGLE RESCUE HOIST KIT	180	ACCESS: EXTERNAL REMOVAL: FIT BOLTS

© Copyright 2024 Leonardo S.p.a.

This document contains information that is confidential and proprietary to Leonardo S.p.a. ('the Company') and is supplied on the express condition that it may not be disclosed to any third party, or reproduced in whole or in part, or used for manufacture, or used for any purpose other than for which it is supplied, without the prior written consent of the Company. Every permitted disclosure, reproduction, adaptation or publication of this document in whole or in part and in any manner or form shall prominently contain this notice



AW189 Maintenance Review Board Report

189G0000M006

Issue V

Page 220 of 275

REVISION STATUS	MRB-R TASK NUMBER	TASK CODE	TASK TITLE	SOURCE	INTERVAL	APPLICABILITY		ZONE	ACCESS & REMARKS
						AW189	AW189ER		
	259101S-04	DI	DETAILED INSPECTION OF ALL MATING SURFACES OF THE SINGLE HOIST TUBE, THE HOIST MOUNTS AND THE HOIST TUBE CLAMPS FOR FRETTING EVIDENCE NOTE: TO BE ACCOMPLISHED IN CONJUNCTION WITH 259101S-02	ED ; CPCP	3200 FH	WITH SINGLE RESCUE HOIST KIT	WITH SINGLE RESCUE HOIST KIT	180	ACCESS: EXTERNAL REMOVAL: HOIST TUBE CLAMPS AND HOIST TUBE ATTACHMENT
SSI 25-91-02: FUSELAGE MOUNTING PLATE ASSY									
	259102S-01	DI	DETAILED INSPECTION OF THE FUSELAGE MOUNTING PLATE ASSY	ED ; CPCP	8 YR	WITH SINGLE OR DUAL RESCUE HOIST KIT	WITH SINGLE OR DUAL RESCUE HOIST KIT	180	ACCESS: EXTERNAL REMOVAL: HOIST STRUCTURAL SUPPORT ASSY, OR DUAL HOIST STRUCTURAL ASSY, AS APPLICABLE
	259102S-02	DI	DETAILED INSPECTION OF THE FUSELAGE MOUNTING PLATE ANCHOR BOLTS	ED ; CPCP	2 YR	WITH SINGLE OR DUAL RESCUE HOIST KIT	WITH SINGLE OR DUAL RESCUE HOIST KIT	180	ACCESS: EXTERNAL ; 182A ; 227L ; 227M REMOVAL: ANCHOR BOLT

© Copyright 2024 Leonardo S.p.a.

This document contains information that is confidential and proprietary to Leonardo S.p.a. ('the Company') and is supplied on the express condition that it may not be disclosed to any third party, or reproduced in whole or in part, or used for manufacture, or used for any purpose other than for which it is supplied, without the prior written consent of the Company. Every permitted disclosure, reproduction, adaptation or publication of this document in whole or in part and in any manner or form shall prominently contain this notice



AW189 Maintenance Review Board Report

189G0000M006

Issue V

Page 221 of 275

REVISION STATUS	MRB-R TASK NUMBER	TASK CODE	TASK TITLE	SOURCE	INTERVAL	APPLICABILITY		ZONE	ACCESS & REMARKS
						AW189	AW189ER		
SSI 25-91-03: DUAL HOIST STRUCTURAL SUPPORT ASSY									
	259103S-01	DI	DETAILED INSPECTION OF THE HOIST MOUNT METALLIC PARTS	ED ; CPCP	8 YR	WITH DUAL RESCUE HOIST KIT	WITH DUAL RESCUE HOIST KIT	180	ACCESS: EXTERNAL
	259103S-02	DI	DETAILED INSPECTION OF MATING SURFACES OF THE FITTING POST AND THE ASSOCIATED DOWEL FOR FRETTING EVIDENCE AND OF ALL THE DUAL HOIST FIT BOLTS	ED ; CPCP	2000 FH ; 2 YR	WITH DUAL RESCUE HOIST KIT	WITH DUAL RESCUE HOIST KIT	180	ACCESS: EXTERNAL REMOVAL: FIT BOLTS ; FITTING POST AND THE ASSOCIATED DOWEL
SSI 25-91-05: SINGLE HOIST SUPPORT BOOM ASSY									
	259105S-01	DI	DETAILED INSPECTION OF THE VISIBLE PART OF THE SINGLE HOIST STRUCTURAL BOOM ASSY AND RESCUE HOIST ANCHOR BOLTS CONNECTING THE BOOM SHOULD BE ACCOMPLISHED IN CONJUNCTION WITH 259105S-03	AD; ED ; CPCP	4 YR	WITH FOLDABLE RESCUE HOIST KIT	WITH FOLDABLE RESCUE HOIST KIT	180	ACCESS: EXTERNAL REMOVAL: RESCUE HOIST ANCHOR BOLTS (2 OFF)

© Copyright 2024 Leonardo S.p.a.

This document contains information that is confidential and proprietary to Leonardo S.p.a. ('the Company') and is supplied on the express condition that it may not be disclosed to any third party, or reproduced in whole or in part, or used for manufacture, or used for any purpose other than for which it is supplied, without the prior written consent of the Company. Every permitted disclosure, reproduction, adaptation or publication of this document in whole or in part and in any manner or form shall prominently contain this notice



AW189 Maintenance Review Board Report

189G0000M006

Issue V

Page 222 of 275

REVISION STATUS	MRB-R TASK NUMBER	TASK CODE	TASK TITLE	SOURCE	INTERVAL	APPLICABILITY		ZONE	ACCESS & REMARKS
						AW189	AW189ER		
	259105S-02	DI	DETAILED INSPECTION OF THE SINGLE HOIST BOOM TRUNNION BALL BEARING AND ROTARY ACTUATOR BASE PLATE INCLUDING ANCHOR BOLTS	ED ; CPCP	2 YR	WITH FOLDABLE RESCUE HOIST KIT	WITH FOLDABLE RESCUE HOIST KIT	180	ACCESS: EXTERNAL REMOVAL: HOIST SUPPORT BOOM DISPLACED TO GET ACCESS TO THE BEARING WITH REMOVAL OF BASE PLATE.
	259105S-03	DI	DETAILED INSPECTION OF THE MATING SURFACES OF THE HOIST SUPPORT BOOM AND THE RESCUE HOIST SHOULD BE ACCOMPLISHED IN CONJUNCTION WITH 259105S-01	ED ; CPCP	2000 FH	WITH FOLDABLE RESCUE HOIST KIT	WITH FOLDABLE RESCUE HOIST KIT	180	ACCESS: EXTERNAL REMOVAL: RESCUE HOIST ASSY FROM THE HOIST BOOM.
SSI 25-91-06: HOIST SUPPORT BASE									
	259106S-01	DI	DETAILED INSPECTION OF THE HOIST SUPPORT AND ADAPTER PLATE. SHOULD BE ACCOMPLISHED IN CONJUNCTION WITH 259106S-04	ED ; CPCP	8 YR	WITH FOLDABLE RESCUE HOIST KIT	WITH FOLDABLE RESCUE HOIST KIT	180	ACCESS: EXTERNAL REMOVAL: HOIST SUPPORT BASE DISASSEMBLY.

© Copyright 2024 Leonardo S.p.a.

This document contains information that is confidential and proprietary to Leonardo S.p.a. ('the Company') and is supplied on the express condition that it may not be disclosed to any third party, or reproduced in whole or in part, or used for manufacture, or used for any purpose other than for which it is supplied, without the prior written consent of the Company. Every permitted disclosure, reproduction, adaptation or publication of this document in whole or in part and in any manner or form shall prominently contain this notice



AW189 Maintenance Review Board Report

189G0000M006

Issue V

Page 223 of 275

REVISION STATUS	MRB-R TASK NUMBER	TASK CODE	TASK TITLE	SOURCE	INTERVAL	APPLICABILITY		ZONE	ACCESS & REMARKS
						AW189	AW189ER		
	259106S-02	DI	DETAILED INSPECTION OF THE HOIST SUPPORT-ADAPTER PLATE FIT BOLTS AND THE HOIST SUPPORT BASE ANCHOR BOLTS.	ED ; CPCP	2 YR	WITH FOLDABLE RESCUE HOIST KIT	WITH FOLDABLE RESCUE HOIST KIT	180	ACCESS: EXTERNAL REMOVAL: ANCHOR BOLTS
	259106S-03	DI	DETAILED INSPECTION OF THE HOIST SUPPORT BASE ANCHOR BOLT BARREL NUTS	ED ; CPCP	8 YR	WITH FOLDABLE RESCUE HOIST KIT	WITH FOLDABLE RESCUE HOIST KIT	180	ACCESS: EXTERNAL 182A, 227L, 227M REMOVAL: BAREL NUT REMOVAL.
	259106S-04	FC	FUNCTIONAL CHECK (TORQUE CHECK) OF THE HOIST SUPPORT-ADAPTER PLATE FIT BOLTS SHOULD BE ACCOMPLISHED IN CONJUNCTION WITH 259106S-01	ED ; CPCP	3200FH	WITH FOLDABLE RESCUE HOIST KIT	WITH FOLDABLE RESCUE HOIST KIT	180	ACCESS: EXTERNAL
ATA 32: LANDING GEAR									
SSI 32-10-01/02: LH/RH MAIN LANDING GEAR ASSY									

© Copyright 2024 Leonardo S.p.a.

This document contains information that is confidential and proprietary to Leonardo S.p.a. ('the Company') and is supplied on the express condition that it may not be disclosed to any third party, or reproduced in whole or in part, or used for manufacture, or used for any purpose other than for which it is supplied, without the prior written consent of the Company. Every permitted disclosure, reproduction, adaptation or publication of this document in whole or in part and in any manner or form shall prominently contain this notice



AW189 Maintenance Review Board Report

189G0000M006

Issue V

Page 224 of 275

REVISION STATUS	MRB-R TASK NUMBER	TASK CODE	TASK TITLE	SOURCE	INTERVAL	APPLICABILITY		ZONE	ACCESS & REMARKS
						AW189	AW189ER		
	321001S-01	LU	LUBRICATION (GREASING) OF THE LH/RH LINK PIVOTS BETWEEN SHOCK ABSORBER AND LEVER (SA-LV) AND LH/RH LINK PIVOTS BETWEEN TRAILING ARM AND SHOCK ABSORBER (TA-SA) NOTE: SHOULD BE ACCOMPLISHED IN CONJUNCTION WITH 321000M-05	ED ; CPCP	1 YR	YES	YES	155 ; 156 ; 720 ; 730	ACCESS: 156A ;157A
	321001S-02	DI	DETAILED INSPECTION OF THE LH/RH TRAILING ARM AXLES (INCLUDING ADJACENT AREAS) AND THE VISIBLE PARTS OF THE LH/RH WHEEL HUB ROLLER BEARINGS NOTE: ROTORCRAFT JACKED	ED ; CPCP	1 YR	YES	YES	720 ; 730	ACCESS: EXTERNAL REMOVAL: MLG WHEEL
	321001S-03	DI	DETAILED INSPECTION OF THE LH/RH TRAILING ARM ASSY'S, VISIBLE PART OF WHEEL HUBS AND LOWER PART OF SHOCK ABSORBER	AD ; ED ; CPCP	2 YR	YES	YES	720 ; 730	ACCESS: EXTERNAL

© Copyright 2024 Leonardo S.p.a.

This document contains information that is confidential and proprietary to Leonardo S.p.a. ('the Company') and is supplied on the express condition that it may not be disclosed to any third party, or reproduced in whole or in part, or used for manufacture, or used for any purpose other than for which it is supplied, without the prior written consent of the Company. Every permitted disclosure, reproduction, adaptation or publication of this document in whole or in part and in any manner or form shall prominently contain this notice



AW189 Maintenance Review Board Report

189G0000M006

Issue V

Page 225 of 275

REVISION STATUS	MRB-R TASK NUMBER	TASK CODE	TASK TITLE	SOURCE	INTERVAL	APPLICABILITY		ZONE	ACCESS & REMARKS
						AW189	AW189ER		
	321001S-04	DI	DETAILED INSPECTION OF THE LH/RH LINK PIVOTS BETWEEN TRAILING ARM AND SHOCK ABSORBER (TA-SA) NOTE: ROTORCRAFT JACKED	ED ; CPCP	2 YR	YES	YES	720 ; 730	ACCESS: EXTERNAL REMOVAL: LINK PIVOTS
	321001S-05	DI	DETAILED INSPECTION OF THE LH/RH LINK PIVOTS BETWEEN SHOCK ABSORBER AND LEVER (SA-LV) NOTE 1: ROTORCRAFT JACKED NOTE 2: SHOULD BE ACCOMPLISHED IN CONJUNCTION WITH 321001S-06	ED ; CPCP	4 YR	YES	YES	155 ; 156 ; 720 ; 730	ACCESS: 156A ; 157A ; 229 B ; 229 C REMOVAL: LINK PIVOTS
	321001S-06	DI	DETAILED INSPECTION OF THE VISIBLE PARTS OF THE LH/RH SHOCK ABSORBER SPHERICAL BEARINGS NOTE: SHOULD BE ACCOMPLISHED IN CONJUNCTION WITH 321001S-05	ED ; CPCP	4 YR	YES	YES	155 ; 156 ; 720 ; 730	ACCESS: 156A ; 157A ; 229 B ; 229 C

© Copyright 2024 Leonardo S.p.a.

This document contains information that is confidential and proprietary to Leonardo S.p.a. ('the Company') and is supplied on the express condition that it may not be disclosed to any third party, or reproduced in whole or in part, or used for manufacture, or used for any purpose other than for which it is supplied, without the prior written consent of the Company. Every permitted disclosure, reproduction, adaptation or publication of this document in whole or in part and in any manner or form shall prominently contain this notice



AW189 Maintenance Review Board Report

189G0000M006

Issue V

Page 226 of 275

REVISION STATUS	MRB-R TASK NUMBER	TASK CODE	TASK TITLE	SOURCE	INTERVAL	APPLICABILITY		ZONE	ACCESS & REMARKS
						AW189	AW189ER		
	321001S-07	DI	DETAILED INSPECTION OF THE VISIBLE PARTS OF THE LH/RH RETRACTING ACTUATOR SPHERICAL BEARINGS NOTE 1: ROTORCRAFT JACKED NOTE 2: IF APPLICABLE, SHOULD BE ACCOMPLISHED IN CONJUNCTION WITH 321001S-09	ED ; CPCP	4 YR	YES	YES	155 ; 156	ACCESS: 156A ;157A ; 229 B ; 229 CREMOVAL: LH/RHRETRACTING ACTUATORS
	321001S-08	DI	DETAILED INSPECTION OF THE LH/RH SHOCK ABSORBERS, LH/RH LEVERS AND LH/RH RETRACTING ACTUATORS	AD ; ED ; CPCP	6 YR	YES	YES	155 ; 156 ; 720 ; 730	ACCESS: 156A ; 157A ; 229 B ; 229 C
	321001S-09	DI	DETAILED INSPECTION OF THE LH/RH LINK PIVOTS (RA-LV) NOTE 1: ROTORCRAFT JACKED NOTE 2: SHOULD BE ACCOMPLISHED IN CONJUNCTION WITH 321001S-07	ED ; CPCP	8 YR	YES	YES	155 ; 156	ACCESS: 156A ; 157A ; 229 B ; 229 C REMOVAL: LINK PIVOTS
SSI 32-20-01: NOSE LANDING GEAR ASSY									

© Copyright 2024 Leonardo S.p.a.

This document contains information that is confidential and proprietary to Leonardo S.p.a. ('the Company') and is supplied on the express condition that it may not be disclosed to any third party, or reproduced in whole or in part, or used for manufacture, or used for any purpose other than for which it is supplied, without the prior written consent of the Company. Every permitted disclosure, reproduction, adaptation or publication of this document in whole or in part and in any manner or form shall prominently contain this notice



AW189 Maintenance Review Board Report

189G0000M006

Issue V

Page 227 of 275

REVISION STATUS	MRB-R TASK NUMBER	TASK CODE	TASK TITLE	SOURCE	INTERVAL	APPLICABILITY		ZONE	ACCESS & REMARKS
						AW189	AW189ER		
	322001S-01	DI	DETAILED INSPECTION OF THE VISIBLE PARTS OF THE NLG WHEEL AXLE AND THE NLG SLIDING TUBE	ED ; CPCP	1 YR	YES	YES	710	ACCESS: EXTERNAL
	322001S-02	DI	DETAILED INSPECTION OF THE VISIBLE PART OF THE NLG WHEEL HUBS, RELEVANT WHEEL HUB ROLLER BEARINGS AND THE MATING SURFACE OF WHEEL AXLE NOTE 1: ROTORCRAFT JACKED NOTE 2: SHOUL BE ACCOMPLISHED IN CONJUNCTION WITH 322001S-03	ED ; CPCP	2 YR	YES	YES	710	ACCESS: EXTERNAL REMOVAL: NLG WHEELS
	322001S-03	DI	DETAILED INSPECTION OF THE NLG RETRACTING ACTUATOR (RA) PIN NOTE 1: ROTORCRAFT JACKED NOTE2: SHOULD BE ACCOMPLISHED IN CONJUNCTION WITH 322001S-02	ED ; CPCP	2 YR	YES	YES	110	ACCESS: EXTERNAL REMOVAL: RA PIN

© Copyright 2024 Leonardo S.p.a.

This document contains information that is confidential and proprietary to Leonardo S.p.a. ('the Company') and is supplied on the express condition that it may not be disclosed to any third party, or reproduced in whole or in part, or used for manufacture, or used for any purpose other than for which it is supplied, without the prior written consent of the Company. Every permitted disclosure, reproduction, adaptation or publication of this document in whole or in part and in any manner or form shall prominently contain this notice



AW189 Maintenance Review Board Report

189G0000M006

Issue V

Page 228 of 275

REVISION STATUS	MRB-R TASK NUMBER	TASK CODE	TASK TITLE	SOURCE	INTERVAL	APPLICABILITY		ZONE	ACCESS & REMARKS
						AW189	AW189ER		
	322001S-04	DI	DETAILED INSPECTION OF THE NLG SHOCK STRUCTURE ASSY (INCLUDING WHEEL HUBS)	AD	2 YR	YES	YES	710 ; 110	ACCESS: EXTERNAL
	322001S-05	DI	DETAILED INSPECTION OF THE NLG CUFF ASSY, THE NLG MAIN FITTING, THE TORQUE LINKS, NLG PINTLE PINS, NLG TORQUE LINK PINS AND NLG TORQUE LINK APEX SCREW NOTE: ROTORCRAFT JACKED	ED ; CPCP	4 YR	YES	YES	710 ; 110	ACCESS: COCKPIT DOORS REMOVAL: PINTLE PINS ; TORQUE LINK PINS ; TORQUE LINK APEX SCREW
	322001S-06	DI	DETAILED INSPECTION OF THE NLG RETRACTING ACTUATOR AND THE VISIBLE PARTS OF THE NLG RETRACTING ACTUATOR SPHERICAL BEARINGS	AD ; ED ; CPCP	6 YR	YES	YES	110 ; 120	ACCESS: 213A ; 217A ; 217B
ATA 49: AIRBORNE AUXILIARY POWER									
SSI 49-10-01: APU ATTACHMENT ASSY									
	491001S-01	DI	DETAILED INSPECTION OF THE VISIBLE PARTS OF THE APU ATTACHMENT SPHERICAL BEARINGS	ED ; CPCP	2 YR	YES	YES	460	ACCESS: 481A ; 461A ; 462A ; 463A

© Copyright 2024 Leonardo S.p.a.

This document contains information that is confidential and proprietary to Leonardo S.p.a. ('the Company') and is supplied on the express condition that it may not be disclosed to any third party, or reproduced in whole or in part, or used for manufacture, or used for any purpose other than for which it is supplied, without the prior written consent of the Company. Every permitted disclosure, reproduction, adaptation or publication of this document in whole or in part and in any manner or form shall prominently contain this notice



AW189 Maintenance Review Board Report

189G0000M006

Issue V

Page 229 of 275

REVISION STATUS	MRB-R TASK NUMBER	TASK CODE	TASK TITLE	SOURCE	INTERVAL	APPLICABILITY		ZONE	ACCESS & REMARKS
						AW189	AW189ER		
	491001S-02	DI	DETAILED INSPECTION OF THE RH FWD APU BEARING HOUSING AND REAR APU MOUNT INSTALLATION FOR EVIDENCE OF FRETTING	ED ; CPCP	3200 FH	YES	YES	460	ACCESS: 481A ; 461A ; 462A ; 463A
ATA 52: DOORS									
SSI 52-11-03/05: LH/RH COCKPIT DOOR LOWER HINGE ASSY									
	521103S-01	DI	DETAILED INSPECTION OF THE VISIBLE PART OF LH/RH COCKPIT DOOR LOWER HINGE ASSY'S	AD; ED ; CPCP	4 YR	YES	YES	210	ACCESS: CREW DOOR REMOVAL: PILOTS DOORS
ATA 52: DOORS									
SSI 52-13-01/02/03/04/05/06: LH/RH UPPER FWD/AFT HINGE-TROLLEY ASSY, LH/RH LOWER FWD HINGE-TROLLEY ASSY									
	521301S-01	DI	DETAILED INSPECTION OF ROLLER BEARING VISIBLE AREA OF THE LH/RH DOOR HINGE-TROLLEY ASSYS	AD; ED ; CPCP	2 YR	YES	YES	220	ACCESS: EXTERNAL
ATA 53: FUSELAGE STRUCTURE									
SSI 53-10-02/03: LH/RH MLG JOINT ASSY									

© Copyright 2024 Leonardo S.p.a.

This document contains information that is confidential and proprietary to Leonardo S.p.a. ('the Company') and is supplied on the express condition that it may not be disclosed to any third party, or reproduced in whole or in part, or used for manufacture, or used for any purpose other than for which it is supplied, without the prior written consent of the Company. Every permitted disclosure, reproduction, adaptation or publication of this document in whole or in part and in any manner or form shall prominently contain this notice



AW189 Maintenance Review Board Report

189G0000M006

Issue V

Page 230 of 275

REVISION STATUS	MRB-R TASK NUMBER	TASK CODE	TASK TITLE	SOURCE	INTERVAL	APPLICABILITY		ZONE	ACCESS & REMARKS
						AW189	AW189ER		
	531002S-01	DI	DETAILED INSPECTION OF THE LH/RH MAIN LANDING GEAR (MLG) JOINT PINS AND LH/RH SPECIAL BOLTS	ED ; CPCP	8 YR	YES	YES	150	ACCESS: 156A ;229B ; 151A ; 151B ; 151C ;157A ; 229C ; 152A ; 152B ; 152CREMOVAL: LANDING GEAR ; PINS AND SPECIAL BOLTS
SSI 53-30-01/03: LH/RH STA5700 SIDE FRAME									
	533001S-01	DI	DETAILED INSPECTION OF THE LH/RH STA5700 SIDE FRAMES IN THE AREAS OF THE LOWER LUGS AND IN THE MAIN LANDING GEAR (MLG) COMPARTMENTS NOTE: SHOULD BE ACCOMPLISHED IN CONJUNCTION WITH 533002S-01 ; 533507S-01 ; 533508S-01	AD ; ED ; CPCP	2 YR	YES	YES	150	(WITH FLOAT INSTALLED) ACCESS: 156A ; 151A ; 151B ; 157A ; 152A ; 152B (BASIC CONFIG) ACCESS: 151C ; 156A ; 157A ; 152C
	533001S-02	GVI	GENERAL VISUAL INSPECTION OF PANELS COVERING THE LH/RH STA5700 SIDE FRAMES INSIDE THE MAIN CABIN	AD	2 YR	YES	YES	220	ACCESS: PASSENGER DOOR

© Copyright 2024 Leonardo S.p.a.

This document contains information that is confidential and proprietary to Leonardo S.p.a. ('the Company') and is supplied on the express condition that it may not be disclosed to any third party, or reproduced in whole or in part, or used for manufacture, or used for any purpose other than for which it is supplied, without the prior written consent of the Company. Every permitted disclosure, reproduction, adaptation or publication of this document in whole or in part and in any manner or form shall prominently contain this notice



AW189 Maintenance Review Board Report

189G0000M006

Issue V

Page 231 of 275

REVISION STATUS	MRB-R TASK NUMBER	TASK CODE	TASK TITLE	SOURCE	INTERVAL	APPLICABILITY		ZONE	ACCESS & REMARKS
						AW189	AW189ER		
	533001S-03	FC	FUNCTIONAL CHECK (TORQUE CHECK) OF THE LH/RH STA5700 MAIN LANDING GEAR (MLG) FITTINGS ANCHOR BOLTS NOTE 1: TO BE ACCOMPLISHED BEFORE 533508S-02 NOTE 2: IDENTICAL TO 533508S-03	ED ; CPCP	3200 FH ; 4 YR	YES	YES	150	ACCESS: 156A ; 229B ; 224D ; 157A ; 229C ; 225E ; PASSENGER DOOR
	533001S-04	DI	DETAILED INSPECTION OF LH/RH STA5700 SIDE FRAMES IN THE AREAS OF THE FRAME STRENGTHENING ASSY	ED ; CPCP	8 YR	AW189 FROM S/N 49007 TO S/N 49009 AND 49011 WITH REINFORCEMENT 8G5330P01811	NO	220	ACCESS: 224D; 225E
	533001S-05	DI	DETAILED INSPECTION OF LH/RH STA5700 SIDE FRAMES IN THE AREAS OF THE STA 5700 SIDE FRAMES CUT OUT AND STRENGTHENING ASSY	ED ; CPCP	8 YR	FROM S/N 49007 TO S/N 49009 AND 49011 WITH REINFORCEMENT 8G5330P00111 AND 49013, 49014, 49055 (RH SIDE) WITH REINFORCEMENT 8G5330P04311+8G5330P04711	NO	220	ACCESS: 224D ; 225E

© Copyright 2024 Leonardo S.p.a.

This document contains information that is confidential and proprietary to Leonardo S.p.a. ('the Company') and is supplied on the express condition that it may not be disclosed to any third party, or reproduced in whole or in part, or used for manufacture, or used for any purpose other than for which it is supplied, without the prior written consent of the Company. Every permitted disclosure, reproduction, adaptation or publication of this document in whole or in part and in any manner or form shall prominently contain this notice



AW189 Maintenance Review Board Report

189G0000M006

Issue V

Page 232 of 275

REVISION STATUS	MRB-R TASK NUMBER	TASK CODE	TASK TITLE	SOURCE	INTERVAL	APPLICABILITY		ZONE	ACCESS & REMARKS
						AW189	AW189ER		
SSI 53-30-02/04: LH/RH BL950 UNDER FLOOR LONGERON									
	533002S-01	DI	DETAILED INSPECTION OF THE LH/RH BL950 UNDER FLOOR LONGERONS IN THE MAIN LANDING GEAR (MLG) COMPARTMENTS NOTE: SHOULD BE ACCOMPLISHED IN CONJUNCTION WITH 533001S-01 , 533507S-01 AND 533508S-01	AD ; ED ; CPCP	2 YR	YES	YES	150	ACCESS: 151A ; 152A
SSI 53-31-01, 53-32-01: FLOOR STRUCTURE ASSY, WL1050 CABIN FLOOR PANEL									
	533101S-01	DI	DETAILED INSPECTION OF THE UPPER SURFACE OF THE WL1050 PANELS IN THE COCKPIT	AD ; ED ; CPCP	4 YR	YES	NO	120	ACCESS: COCKPIT DOORS
	533101S-02	DI	DETAILED INSPECTION OF THE LOWER SURFACE OF THE H/C LOWER PANELS	ED ; CPCP	2 YR	YES	NO	120 ; 130 ; 140	ACCESS: EXTERNAL
	533101S-03	GVI	GENERAL VISUAL INSPECTION OF THE UPPER SURFACE OF THE WL1050 INTERSEAT PANEL	AD	2 YR	YES	NO	120	ACCESS: 213A ; 217A ; 217B ; NLG EXTENDED

© Copyright 2024 Leonardo S.p.a.

This document contains information that is confidential and proprietary to Leonardo S.p.a. ('the Company') and is supplied on the express condition that it may not be disclosed to any third party, or reproduced in whole or in part, or used for manufacture, or used for any purpose other than for which it is supplied, without the prior written consent of the Company. Every permitted disclosure, reproduction, adaptation or publication of this document in whole or in part and in any manner or form shall prominently contain this notice



AW189 Maintenance Review Board Report

189G0000M006

Issue V

Page 233 of 275

REVISION STATUS	MRB-R TASK NUMBER	TASK CODE	TASK TITLE	SOURCE	INTERVAL	APPLICABILITY		ZONE	ACCESS & REMARKS
						AW189	AW189ER		
	533101S-04	DI	DETAILED INSPECTION OF THE STRUCTURE IN THE INTERNAL AREA BETWEEN COCKPIT WL1050 PANEL AND LOWER PANELS (INCLUDING INTERNAL PANEL SURFACES)	ED ; CPCP	4 YR	YES	NO	120	ACCESS: 122A ; 125A
	533101S-05	DI	DETAILED INSPECTION OF THE STRUCTURE IN THE INTERNAL AREA BETWEEN CABIN WL1050 PANEL AND LOWER PANELS (INCLUDING INTERNAL PANEL SURFACES)	ED ; CPCP	4 YR	YES	NO	130; 140	ACCESS: 221A ; 222A ; 223A
	533101S-06	DI	DETAILED INSPECTION OF UPPER AND LOWER SURFACES OF THE WL1050 INTERSEAT PANEL	ED	8 YR	YES	NO	120	ACCESS: 123A ; 124A ; 213A ; 217A ; 217B ; NLG EXTENDED
	533101S-07	DI	DETAILED INSPECTION OF THE UPPER SURFACE OF THE WL1050 PANELS IN THE CABIN	AD ; ED ; CPCP	4 YR ; NOTE_B	YES	NO	220	ACCESS: PASSENGER DOOR

© Copyright 2024 Leonardo S.p.a.

This document contains information that is confidential and proprietary to Leonardo S.p.a. ('the Company') and is supplied on the express condition that it may not be disclosed to any third party, or reproduced in whole or in part, or used for manufacture, or used for any purpose other than for which it is supplied, without the prior written consent of the Company. Every permitted disclosure, reproduction, adaptation or publication of this document in whole or in part and in any manner or form shall prominently contain this notice



AW189 Maintenance Review Board Report

189G0000M006

Issue V

Page 234 of 275

REVISION STATUS	MRB-R TASK NUMBER	TASK CODE	TASK TITLE	SOURCE	INTERVAL	APPLICABILITY		ZONE	ACCESS & REMARKS
						AW189	AW189ER		
SSI 53-31-02 , 53-31-03 , 53-31-04: LH/RH STA1785 NLG BRACKET, NLG ACTUATOR FITTING									
	533102S-01	DI	DETAILED INSPECTION OF THE LH/RH STA1785 NOSE LANDING GEAR (NLG) BRACKETS IN THE NLG COMPARTMENT AND VISIBLE PART OF THE RELEVANT SPHERICAL BEARINGS.	AD ; ED ; CPCP	2 YR	YES	YES	110; 120	ACCESS: NLG EXTENDED; COCKPIT DOORS
	533102S-02	DI	DETAILED INSPECTION OF THE NOSE LANDING GEAR (NLG) ACTUATOR FITTING	ED ; CPCP	4 YR	YES	YES	120	ACCESS: 213A ; 217A; 217B
	533102S-03	DI	DETAILED INSPECTION OF THE NOSE LANDING GEAR (NLG) ACTUATOR FITTING ANCHOR BOLTS	ED ; CPCP	4 YR	YES	YES	120	ACCESS: 213A ; 124A ; 217A; 217B REMOVAL: ANCHOR BOLTS
	533102S-04	DI	DETAILED INSPECTION OF THE NOSE LANDING GEAR (NLG) ACTUATOR FITTING JOINT BOLT	ED ; CPCP	4 YR	YES	YES	120	ACCESS: 213A ; 217A; 217B REMOVAL: JOINT BOLTS

© Copyright 2024 Leonardo S.p.a.

This document contains information that is confidential and proprietary to Leonardo S.p.a. ('the Company') and is supplied on the express condition that it may not be disclosed to any third party, or reproduced in whole or in part, or used for manufacture, or used for any purpose other than for which it is supplied, without the prior written consent of the Company. Every permitted disclosure, reproduction, adaptation or publication of this document in whole or in part and in any manner or form shall prominently contain this notice



AW189 Maintenance Review Board Report

189G0000M006

Issue V

Page 235 of 275

REVISION STATUS	MRB-R TASK NUMBER	TASK CODE	TASK TITLE	SOURCE	INTERVAL	APPLICABILITY		ZONE	ACCESS & REMARKS
						AW189	AW189ER		
SSI 53-31-05: INSTRUMENT PANEL FWD SUPPORT LUGS									
	533105S-01	DI	DETAILED INSPECTION OF THE INSTRUMENT PANEL FWD RIB LUGS AND ASSOCIATED SLIP BUSHINGS FOR EVIDENCES OF FRETTING (ANCHOR BOLTS AND SLIP BUSHINGS REMOVED) NOTE: APPLICABLE TO INSTRUMENT INST. 8G3110A00111	ED	400 FH	YES	YES	210	ACCESS: COCKPIT DOORS
	533105S-02	DI	DETAILED INSPECTION OF THE INSTRUMENT PANEL FWD RIB LUGS AND ASSOCIATED SLIP BUSHINGS FOR EVIDENCES OF FRETTING (ANCHOR BOLTS AND SLIP BUSHINGS REMOVED) NOTE: APPLICABLE TO INSTRUMENT INST. 8G3110A00111 WITH MODIFICATION 8G3110P00611	ED	800 FH	YES	YES	210	ACCESS: COCKPIT DOORS
SSI 53-31-06, 53-32-02: FLOOR STRUCTURE ASSY , CABIN FLOOR PANEL UNDERBELLY TANK									
	533106S-01	DI	DETAILED INSPECTION OF THE UPPER SURFACE OF THE WL1050 FLOOR PANELS IN THE COCKPIT	AD ; ED ; CPCP	4 YR	NO	YES	210	ACCESS: COCKPIT DOORS

© Copyright 2024 Leonardo S.p.a.

This document contains information that is confidential and proprietary to Leonardo S.p.a. ('the Company') and is supplied on the express condition that it may not be disclosed to any third party, or reproduced in whole or in part, or used for manufacture, or used for any purpose other than for which it is supplied, without the prior written consent of the Company. Every permitted disclosure, reproduction, adaptation or publication of this document in whole or in part and in any manner or form shall prominently contain this notice



AW189 Maintenance Review Board Report

189G0000M006

Issue V

Page 236 of 275

REVISION STATUS	MRB-R TASK NUMBER	TASK CODE	TASK TITLE	SOURCE	INTERVAL	APPLICABILITY		ZONE	ACCESS & REMARKS
						AW189	AW189ER		
	533106S-02	DI	DETAILED INSPECTION OF THE LOWER SURFACES OF THE LOWER PANELS IN THE UNDERBELLY AND COCKPIT AREAS	AD ; ED ; CPCP	2 YR	NO	YES	120 ; 130 ; 140	ACCESS: EXTERNAL REMOVAL: FWD UNDERBELLY FAIRINGS
	533106S-03	GVI	GENERAL VISUAL INSPECTION OF THE UPPER SURFACE OF THE WL1050 INTERSEAT PANEL	AD	2 YR	NO	YES	120	ACCESS: NLG EXTENDED ; 213A ; 217A ; 217B ; 217C
	533106S-04	DI	DETAILED INSPECTION OF THE STRUCTURE IN THE INTERNAL AREA BETWEEN WL1050 COCKPIT PANEL AND LOWER PANELS (INCLUDING INTERNAL PANEL SURFACES)	ED ; CPCP	4 YR	NO	YES	120	ACCESS: 122A ; 125A ; REMOVAL: FWD UNDERBELLY FAIRINGS
	533106S-05	DI	DETAILED INSPECTION OF VISIBLE PARTS OF THE STRUCTURE IN THE INTERNAL AREA BETWEEN WL1050 CABIN PANEL AND UNDERBELLY LOWER PANELS (INCLUDING INTERNAL PANEL SURFACES)	ED ; CPCP	4 YR	NO	YES	130 ; 140	ACCESS: 221A ; 222A ; 223A ; REMOVABLE UNDERBELLY PANEL

© Copyright 2024 Leonardo S.p.a.

This document contains information that is confidential and proprietary to Leonardo S.p.a. ('the Company') and is supplied on the express condition that it may not be disclosed to any third party, or reproduced in whole or in part, or used for manufacture, or used for any purpose other than for which it is supplied, without the prior written consent of the Company. Every permitted disclosure, reproduction, adaptation or publication of this document in whole or in part and in any manner or form shall prominently contain this notice



AW189 Maintenance Review Board Report

189G0000M006

Issue V

Page 237 of 275

REVISION STATUS	MRB-R TASK NUMBER	TASK CODE	TASK TITLE	SOURCE	INTERVAL	APPLICABILITY		ZONE	ACCESS & REMARKS
						AW189	AW189ER		
	533106S-06	DI	DETAILED INSPECTION OF UPPER AND LOWER SURFACES OF THE WL1050 INTERSEAT PANEL	ED	8 YR	NO	YES	120	ACCESS: NLG EXTENDED ; 123A ; 124A ; 213A ; 217A ; 217B ; 217C REMOVAL: FWD UNDERBELLY FAIRINGS
	533106S-07	DI	DETAILED INSPECTION OF THE UPPER SURFACE OF THE WL1050 PANELS IN THE CABIN	AD ; ED ; CPCP	4 YR ; NOTE_B	NO	YES	220	ACCESS: PASSENGER DOORS
	533106S-08	DI	DETAILED INSPECTION OF THE EXTERNAL SURFACE OF THE EXTERNAL UNDERBELLY LONGERONS	ED ; CPCP	4 YR	NO	YES	130 ; 140	REMOVAL: LATERAL UNDERBELLY FAIRINGS
SSI 53-33-01: UPPER STRUCTURE ASSY									
	533301S-01	DI	DETAILED INSPECTION OF VISIBLE PARTS OF THE UPPER SURFACE OF WL2670 PANEL	AD	2 YR	YES	YES	450 ; 460 ; 470	ACCESS: 451A ; 471A ; 472A ; 461A ; 463A
	533301S-02	GVI	GENERAL VISUAL INSPECTION OF THE LOWER SURFACE OF THE WL2470 PANEL	AD ; ED ; CPCP	4 YR	YES	YES	220	ACCESS: PASSENGER DOORS REMOVAL: ROOF LINERS

© Copyright 2024 Leonardo S.p.a.

This document contains information that is confidential and proprietary to Leonardo S.p.a. ('the Company') and is supplied on the express condition that it may not be disclosed to any third party, or reproduced in whole or in part, or used for manufacture, or used for any purpose other than for which it is supplied, without the prior written consent of the Company. Every permitted disclosure, reproduction, adaptation or publication of this document in whole or in part and in any manner or form shall prominently contain this notice



AW189 Maintenance Review Board Report

189G0000M006

Issue V

Page 238 of 275

REVISION STATUS	MRB-R TASK NUMBER	TASK CODE	TASK TITLE	SOURCE	INTERVAL	APPLICABILITY		ZONE	ACCESS & REMARKS
						AW189	AW189ER		
	533301S-03	DI	DETAILED INSPECTION OF THE UPPER SURFACE OF WL2670 PANEL	ED ; CPCP	4 YR	YES	YES	450 ; 460 ; 470	ACCESS: 451A ; 471A ; 472A ; 461A ; 463A ; 481A REMOVAL: AIR INTAKE
	533301S-04	DI	DETAILED INSPECTION OF THE AREAS BELOW THE TITANIUM PANELS, MAINLY DEDICATED TO THE LONGERON UPPER FLANGES ADJACENT TO THE TITANIUM PANELS AND TO THE BL500 LONGERON SURFACES CLOSE TO THE STA5700 MGB SUPPORT REINFORCEMENTS.	ED ; CPCP	8 YR	YES	YES	190	ACCESS: 228A ; 228B ; 228C REMOVAL: ROOF LINERS
SSI 53-33-02: MAIN GEAR BOX SUPPORT STRUCTURE									
	533302S-01	DI	DETAILED INSPECTION OF THE BL550 LH/RH CENTRE LONGERONS AND THE LH/RH STA5100 ANTI-TORQUE FITTINGS	ED ; CPCP	4 YR	YES	YES	180	ACCESS: 227B ; 227C ; 227D

© Copyright 2024 Leonardo S.p.a.

This document contains information that is confidential and proprietary to Leonardo S.p.a. ('the Company') and is supplied on the express condition that it may not be disclosed to any third party, or reproduced in whole or in part, or used for manufacture, or used for any purpose other than for which it is supplied, without the prior written consent of the Company. Every permitted disclosure, reproduction, adaptation or publication of this document in whole or in part and in any manner or form shall prominently contain this notice



AW189 Maintenance Review Board Report

189G0000M006

Issue V

Page 239 of 275

REVISION STATUS	MRB-R TASK NUMBER	TASK CODE	TASK TITLE	SOURCE	INTERVAL	APPLICABILITY		ZONE	ACCESS & REMARKS
						AW189	AW189ER		
	533302S-02	FC	FUNCTIONAL CHECK (TORQUE CHECK) OF THE LH/RH MAIN GEAR BOX (MGB) FWD BRACKETS ANCHOR BOLTS NOTE: IDENTICAL TO 633006S-04	ED ; CPCP	3200 FH ; 4 YR	YES	YES	450	ACCESS: 451A ; 227B
	533302S-03	FC	FUNCTIONAL CHECK (TORQUE CHECK) OF THE LH/RH REAR MAIN GEAR BOX (MGB) BRACKETS ANCHOR BOLTS NOTE: IDENTICAL TO 633008S-03	ED ; CPCP	3200 FH ; 4 YR	YES	YES	470	ACCESS: 451A ; 227C ; 227D REMOVAL: AIR INTAKES
	533302S-04	FC	FUNCTIONAL CHECK (TORQUE CHECK) OF THE ANTI-TORQUE BEAM ANCHOR BOLTS NOTE: IDENTICAL TO 633010S-02	ED ; CPCP	3200 FH	YES	YES	470	ACCESS: 451A ; 227B
	533302S-05	DI	DETAILED INSPECTION OF THE STA5700 MGB LH SUPPORT, THE STA5700 MGB RH SUPPORT AND THE STA5700 UPPER FRAME WITH SPECIFIC ATTENTION TO THE SURFACES ADJACENT TO THE REINFORCEMENT BORDERS	ED ; CPCP	8 YR	YES	YES	180; 190	ACCESS: 227A ; 227E ; 228A ; 228B ; 228C
SSI 53-33-03: ENGINE SUPPORT STRUCTURE									

© Copyright 2024 Leonardo S.p.a.

This document contains information that is confidential and proprietary to Leonardo S.p.a. ('the Company') and is supplied on the express condition that it may not be disclosed to any third party, or reproduced in whole or in part, or used for manufacture, or used for any purpose other than for which it is supplied, without the prior written consent of the Company. Every permitted disclosure, reproduction, adaptation or publication of this document in whole or in part and in any manner or form shall prominently contain this notice



AW189 Maintenance Review Board Report

189G0000M006

Issue V

Page 240 of 275

REVISION STATUS	MRB-R TASK NUMBER	TASK CODE	TASK TITLE	SOURCE	INTERVAL	APPLICABILITY		ZONE	ACCESS & REMARKS
						AW189	AW189ER		
	533303S-01	DI	DETAILED INSPECTION OF THE ENGINE SUPPORT STRUCTURE	ED ; CPCP	8 YR	YES	YES	190	ACCESS: 228A ; 228B ; 228C
	533303S-02	DI	DETAILED INSPECTION OF THE PORT /STARBOARD ENGINE SUPPORT BRACKETS INSTALLATION FOR EVIDENCE OF FRETTING NOTE: IDENTICAL TO 712002S-02	ED ; CPCP	3200 FH	YES	YES	190 ; 460	ACCESS: 461A ; 463A ; 228A ; 228B ; 228C
SSI 53-35-05/06: LH/RH STA3800 FRAME ASSY									
	533505S-01	GVI	GENERAL VISUAL INSPECTION OF PANELS COVERING THE LH/RH STA3800 FRAME ASSY'S INSIDE THE MAIN CABIN	AD	4 YR	YES	YES	220	ACCESS: PASSENGER DOOR

© Copyright 2024 Leonardo S.p.a.

This document contains information that is confidential and proprietary to Leonardo S.p.a. ('the Company') and is supplied on the express condition that it may not be disclosed to any third party, or reproduced in whole or in part, or used for manufacture, or used for any purpose other than for which it is supplied, without the prior written consent of the Company. Every permitted disclosure, reproduction, adaptation or publication of this document in whole or in part and in any manner or form shall prominently contain this notice



AW189 Maintenance Review Board Report

189G0000M006

Issue V

Page 241 of 275

REVISION STATUS	MRB-R TASK NUMBER	TASK CODE	TASK TITLE	SOURCE	INTERVAL	APPLICABILITY		ZONE	ACCESS & REMARKS
						AW189	AW189ER		
SSI 53-35-07/09: LH/RH STA5700 FRAME REINFORCEMENT									
	533507S-01	DI	DETAILED INSPECTION OF THE LH/RH STA5700 FRAME REINFORCEMENTS IN THE MAIN LANDING GEAR (MLG) COMPARTMENTS NOTE: SHOULD BE ACCOMPLISHED IN CONJUNCTION WITH 533001S-01 , 533002S-01 AND 533508S-01	AD ; ED ; CPCP	2 YR	YES	YES	150	ACCESS: 156A ; 151A ; 151B ; 157A ; 152A ; 152D ; REAR WINDOW TOP HORIZONTAL ACCESS PANEL
SSI 53-35-08/10: LH/RH STA5700 MLG FITTING									
	533508S-01	DI	DETAILED INSPECTION OF THE LH/RH STA5700 MAIN LANDING GEAR (MLG) FITTINGS ASSEMBLY NOTE: SHOULD BE ACCOMPLISHED IN CONJUNCTION WITH 533001S-01 AND 533002S-01 , 533507S-01	ED ; CPCP	2 YR	YES	YES	150	ACCESS: 156A ; 157A

© Copyright 2024 Leonardo S.p.a.

This document contains information that is confidential and proprietary to Leonardo S.p.a. ('the Company') and is supplied on the express condition that it may not be disclosed to any third party, or reproduced in whole or in part, or used for manufacture, or used for any purpose other than for which it is supplied, without the prior written consent of the Company. Every permitted disclosure, reproduction, adaptation or publication of this document in whole or in part and in any manner or form shall prominently contain this notice



AW189 Maintenance Review Board Report

189G0000M006

Issue V

Page 242 of 275

REVISION STATUS	MRB-R TASK NUMBER	TASK CODE	TASK TITLE	SOURCE	INTERVAL	APPLICABILITY		ZONE	ACCESS & REMARKS
						AW189	AW189ER		
	533508S-02	DI	DETAILED INSPECTION OF THE LH/RH STA5700 MAIN LANDING GEAR (MLG) FITTING ANCHOR BOLTS NOTE: TO BE ACCOMPLISHED AFTER 533508S-03	ED ; CPCP	4 YR	YES	YES	150	ACCESS: 156A ; 229B ; 224D ; 157A ; 229C ; 225E ; PASSENGER DOORREMOVAL: ANCHOR BOLTS
	533508S-03	FC	FUNCTIONAL CHECK (TORQUE CHECK) OF THE LH/RH STA5700 MAIN LANDING GEAR (MLG) FITTINGS ANCHOR BOLTS NOTE 1: TO BE ACCOMPLISHED BEFORE 533508S-02 NOTE 2: IDENTICAL TO 533001S-03	ED ; CPCP	3200 FH ; 4 YR	YES	YES	150	ACCESS: 156A ; 229B ; 224D ; 157A ; 229C ; 225E ; PASSENGER DOOR
SSI 53-40-01- REAR FUSELAGE SHEEL									
	534001S-01	DI	DETAILED INSPECTION OF THE REAR ROOF UPPER SURFACE	AD ; ED ; CPCP	4 YR	YES	YES	480	ACCESS: 481A
	534001S-02	DI	DETAILED INSPECTION OF VISIBLE PARTS OF THE REAR ROOF LOWER SURFACE	ED ; CPCP	4 YR	YES	YES	160	ACCESS: 168A ; 169A REMOVAL: UPPER LINERS

© Copyright 2024 Leonardo S.p.a.

This document contains information that is confidential and proprietary to Leonardo S.p.a. ('the Company') and is supplied on the express condition that it may not be disclosed to any third party, or reproduced in whole or in part, or used for manufacture, or used for any purpose other than for which it is supplied, without the prior written consent of the Company. Every permitted disclosure, reproduction, adaptation or publication of this document in whole or in part and in any manner or form shall prominently contain this notice



AW189 Maintenance Review Board Report

189G0000M006

Issue V

Page 243 of 275

REVISION STATUS	MRB-R TASK NUMBER	TASK CODE	TASK TITLE	SOURCE	INTERVAL	APPLICABILITY		ZONE	ACCESS & REMARKS
						AW189	AW189ER		
	534001S-03	GVI	GENERAL VISUAL INSPECTION OF THE INTERNAL AND EXTERNAL LH/RH REAR SIDEWALLS	AD	4 YR	YES	YES	160 ; 480	ACCESS: 163A ; 164A ; 168A ; 169A
	534001S-04	DI	DETAILED INSPECTION OF THE EXTERNAL SURFACE OF THE REAR LOWER PANEL ASSY	AD ; ED ; CPCP	2 YR	YES	YES	480	ACCESS: EXTERNAL
	534001S-05	DI	DETAILED INSPECTION OF THE VISIBLE AREAS OF THE REAR LOWER PANEL ASSY INTERNAL SURFACE	AD ; ED ; CPCP	2 YR	YES	YES	160	ACCESS: 163A ; 164A ; 161A
SSI 53-40-02: REAR FUSELAGE FLOOR									
	534002S-01	DI	DETAILED INSPECTION OF THE UPPER SURFACE OF THE REAR FLOOR PANELS	AD ; ED ; CPCP	2 YR	YES	YES	160	ACCESS: 168A ; 169A
	534002S-02	GVI	GENERAL VISUAL INSPECTION OF THE STA7200 REAR UNDERFLOOR BULKHEAD AND THE STA8150 REAR UNDERFLOOR BULKHEAD	AD	2 YR	YES	YES	160	ACCESS: 163A ; 164A ; 161A
	534002S-03	GVI	GENERAL VISUAL INSPECTION OF LOWER SURFACE OF THE REAR FLOOR PANELS	ED ; CPCP	4 YR	YES	YES	160	ACCESS: 163A ; 164A ; 161A

© Copyright 2024 Leonardo S.p.a.

This document contains information that is confidential and proprietary to Leonardo S.p.a. ('the Company') and is supplied on the express condition that it may not be disclosed to any third party, or reproduced in whole or in part, or used for manufacture, or used for any purpose other than for which it is supplied, without the prior written consent of the Company. Every permitted disclosure, reproduction, adaptation or publication of this document in whole or in part and in any manner or form shall prominently contain this notice



AW189 Maintenance Review Board Report

189G0000M006

Issue V

Page 244 of 275

REVISION STATUS	MRB-R TASK NUMBER	TASK CODE	TASK TITLE	SOURCE	INTERVAL	APPLICABILITY		ZONE	ACCESS & REMARKS
						AW189	AW189ER		
	534002S-04	SDI	SPECIAL DETAILED INSPECTION (TAP TEST) OF THE ACCESSIBLE SURFACES OF THE STA7200 REAR UNDERFLOOR BULKHEAD AND THE STA8150 REAR UNDERFLOOR BULKHEAD	ED	8 YR	YES	YES	160	ACCESS: 163A ; 164A ; 161A ; 165D ; 166A ; 167A
SSI 53-40-03: REAR STA8700 FRAME ASSY									
	534003S-01	DI	DETAILED INSPECTION OF VISIBLE PARTS OF THE REAR STA8700 FRAME ASSY NOTE: SHOULD BE ACCOMPLISHED IN CONJUNCTION WITH 535001S-01	AD	6 YR	YES	YES	160	ACCESS: 168A ; 169A ; 167A ; REMOVAL: LINERS
SSI 53-40-04/05/06/07 , 53-10-01: REAR LH/RH LOWER/UPPER FITTING, REAR TAIL JOINT BOLT									
	534004S-01	FC	FUNCTIONAL CHECK (TORQUE CHECK) OF THE REAR-TAIL JOINT BOLTS NOTE: IDENTICAL TO 535002S-01	ED ; CPCP	3200 FH	YES	YES	160 ; 310	ACCESS: 168A ; 169A ; 167A ;REMOVAL: LINERS

© Copyright 2024 Leonardo S.p.a.

This document contains information that is confidential and proprietary to Leonardo S.p.a. ('the Company') and is supplied on the express condition that it may not be disclosed to any third party, or reproduced in whole or in part, or used for manufacture, or used for any purpose other than for which it is supplied, without the prior written consent of the Company. Every permitted disclosure, reproduction, adaptation or publication of this document in whole or in part and in any manner or form shall prominently contain this notice



AW189 Maintenance Review Board Report

189G0000M006

Issue V

Page 245 of 275

REVISION STATUS	MRB-R TASK NUMBER	TASK CODE	TASK TITLE	SOURCE	INTERVAL	APPLICABILITY		ZONE	ACCESS & REMARKS
						AW189	AW189ER		
SSI 53-50-01: TAIL STA 8701 FRAME ASSY									
	535001S-01	DI	DETAILED INSPECTION OF VISIBLE PARTS OF THE TAIL STA8701 FRAME ASSY NOTE: SHOULD BE ACCOMPLISHED IN CONJUNCTION WITH 534003S-01	AD	6 YR	YES	YES	310	ACCESS: 168A ; 169A REMOVAL: LINERS
SSI 53-50-02/03/04/05: TAIL RH/LH UPPER AND LOWER FITTING									
	535002S-01	FC	FUNCTIONAL CHECK (TORQUE CHECK) OF THE REAR-TAIL JOINT BOLTS NOTE: IDENTICAL TO 534004S-01	ED ; CPCP	3200 FH	YES	YES	160 ; 310	ACCESS: 168A ; 169A ; 167A REMOVAL: LINERS
SSI 53-50-06: TAIL CONE									
	535006S-01	DI	DETAILED INSPECTION OF VISIBLE PARTS OF THE TAIL ROOF PANEL UPPER SURFACE	AD	4 YR	YES	YES	310	ACCESS: 491A ; 492A

© Copyright 2024 Leonardo S.p.a.

This document contains information that is confidential and proprietary to Leonardo S.p.a. ('the Company') and is supplied on the express condition that it may not be disclosed to any third party, or reproduced in whole or in part, or used for manufacture, or used for any purpose other than for which it is supplied, without the prior written consent of the Company. Every permitted disclosure, reproduction, adaptation or publication of this document in whole or in part and in any manner or form shall prominently contain this notice



AW189 Maintenance Review Board Report

189G0000M006

Issue V

Page 246 of 275

REVISION STATUS	MRB-R TASK NUMBER	TASK CODE	TASK TITLE	SOURCE	INTERVAL	APPLICABILITY		ZONE	ACCESS & REMARKS
						AW189	AW189ER		
	535006S-02	GVI	GENERAL VISUAL INSPECTION OF THE EXTERNAL SURFACES THE LH/RH TAIL PANEL ASSYS NOTE: SHOULD BE ACCOMPLISHED IN CONJUNCTION WITH 535007S-01	AD	4 YR	YES	YES	310 ; 321	ACCESS: EXTERNAL
	535006S-03	GVI	GENERAL VISUAL INSPECTION OF THE INTERNAL SURFACES THE LH/RH TAIL PANEL ASSYS	AD	4 YR	YES	YES	310	ACCESS: 311A
	535006S-04	GVI	GENERAL VISUAL INSPECTION OF THE INTERNAL SURFACES OF THE LH/RH TAIL AND BELLY PANEL ASSYS BELOW THE IGB INSTALLATION NOTE: SHOULD BE ACCOMPLISHED IN CONJUNCTION WITH 535007S-02	AD	2 YR	YES	YES	321	ACCESS: 321A
	535006S-05	DI	DETAILED INSPECTION OF EXTERNAL SURFACE OF THE BELLY PANEL ASSY	AD	4 YR	YES	YES	310 ; 321	ACCESS: EXTERNAL

© Copyright 2024 Leonardo S.p.a.

This document contains information that is confidential and proprietary to Leonardo S.p.a. ('the Company') and is supplied on the express condition that it may not be disclosed to any third party, or reproduced in whole or in part, or used for manufacture, or used for any purpose other than for which it is supplied, without the prior written consent of the Company. Every permitted disclosure, reproduction, adaptation or publication of this document in whole or in part and in any manner or form shall prominently contain this notice



AW189 Maintenance Review Board Report

189G0000M006

Issue V

Page 247 of 275

REVISION STATUS	MRB-R TASK NUMBER	TASK CODE	TASK TITLE	SOURCE	INTERVAL	APPLICABILITY		ZONE	ACCESS & REMARKS
						AW189	AW189ER		
	535006S-06	DI	DETAILED INSPECTION OF THE BELLY PANEL AND THE LOWER LONGERONS INSIDE THE TAIL CONE	AD	4 YR	YES	YES	310	ACCESS: 311A
SSI 53-50-07: TAIL FIN									
	535007S-01	GVI	GENERAL VISUAL INSPECTION OF THE EXTERNAL SURFACE OF THE LH/RH TAIL FIN PANEL AND FWD/AFT SPAR ASSYS NOTE: SHOULD BE ACCOMPLISHED IN CONJUNCTION WITH 535006S-02	AD	4 YR	YES	YES	321 ; 322	ACCESS: 492A ; 494A ; 322A ; 321A
	535007S-02	GVI	GENERAL VISUAL INSPECTION OF THE INTERNAL SURFACE OF THE LH/RH TAIL FIN PANEL AND FWD/AFT SPAR ASSYS IN THE AREAS ADJACENT TO IGB AND TGB INSTALLATIONS NOTE: SHOULD BE ACCOMPLISHED IN CONJUNCTION WITH 535006S-04	AD	2 YR	YES	YES	321 ; 322	ACCESS: 311A ; 493A ; 495A

© Copyright 2024 Leonardo S.p.a.

This document contains information that is confidential and proprietary to Leonardo S.p.a. ('the Company') and is supplied on the express condition that it may not be disclosed to any third party, or reproduced in whole or in part, or used for manufacture, or used for any purpose other than for which it is supplied, without the prior written consent of the Company. Every permitted disclosure, reproduction, adaptation or publication of this document in whole or in part and in any manner or form shall prominently contain this notice



AW189 Maintenance Review Board Report

189G0000M006

Issue V

Page 248 of 275

REVISION STATUS	MRB-R TASK NUMBER	TASK CODE	TASK TITLE	SOURCE	INTERVAL	APPLICABILITY		ZONE	ACCESS & REMARKS
						AW189	AW189ER		
SSI 53-50-08: TAIL GEAR BOX (TGB) FITTING									
	535008S-01	DI	DETAILED INSPECTION OF VISIBLE PARTS OF THE TGB FITTING	AD ; ED ; CPCP	4 YR	YES	YES	494	ACCESS: 495A ; 496A
	535008S-02	FC	FUNCTIONAL CHECK (TORQUE CHECK) OF THE TAIL GEAR BOX (TGB) ANCHOR NUTS	ED ; CPCP	3200 FH	YES	YES	494	ACCESS: 495A ; 496A
	535008S-03	DI	DETAILED INSPECTION OF THE TAIL GEAR BOX (TGB) ANCHOR STUDS INTERVAL NOTE: TO BE ACCOMPLISHED AT TGB REMOVAL, NOT EXCEEDING 4 YR	ED ; CPCP	NOTE	YES	YES	494	ACCESS: 495A ; 496A REMOVAL: NUT
SSI 53-50-09: INTERMEDIATE GEAR BOX (IGB) ATTACHEMENT									
	535009S-01	FC	FUNCTIONAL CHECK (TORQUE CHECK) OF THE INTERMEDIATE GEAR BOX (IGB) ANCHOR BOLTS	ED ; CPCP	3200 FH	YES	YES	322	ACCESS: 493A ; 322A
	535009S-02	DI	DETAILED INSPECTION OF THE INTERMEDIATE GEAR BOX (IGB) ANCHOR BOLTS INTERVAL NOTE: TO BE ACCOMPLISHED AT IGB REMOVAL, NOT EXCEEDING 8 YR	ED ; CPCP	NOTE	YES	YES	322	ACCESS: 493A ; 322A REMOVAL: ANCHOR BOLT

© Copyright 2024 Leonardo S.p.a.

This document contains information that is confidential and proprietary to Leonardo S.p.a. ('the Company') and is supplied on the express condition that it may not be disclosed to any third party, or reproduced in whole or in part, or used for manufacture, or used for any purpose other than for which it is supplied, without the prior written consent of the Company. Every permitted disclosure, reproduction, adaptation or publication of this document in whole or in part and in any manner or form shall prominently contain this notice



AW189 Maintenance Review Board Report

189G0000M006

Issue V

Page 249 of 275

REVISION STATUS	MRB-R TASK NUMBER	TASK CODE	TASK TITLE	SOURCE	INTERVAL	APPLICABILITY		ZONE	ACCESS & REMARKS
						AW189	AW189ER		
SSI 53-50-10/11: TAILPLANE UPPER/LOWER FITTING ASSY									
	535010S-01	-	TASK DELETED WITH MRBR ISSUE F	-	-	-	-	-	-
	535010S-02	-	TASK DELETED WITH MRBR ISSUE F	-	-	-	-	-	-
ATA 55: STABILISERS									
SSI 55-10-01/02: TAILPLANE ROD AND FITTING ASSY									
	551001S-01	DI	DETAILED INSPECTION OF THE TAILPLANE ROD SPHERICAL BEARINGS AND OF THE ASSOCIATED UPR JOINT BOLTS	ED ; CPCP	4 YR	YES	YES	323	ACCESS: 321A ; 322A REMOVAL: TAILPLANE JOINT BOLTS
SSI 55-10-03: TAILPLANE ASSY									
	551003S-01	GVI	GENERAL VISUAL INSPECTION OF THE EXTERNAL SURFACE OF THE TAILPLANE ASSY	AD	4 YR	YES	YES	330 ; 340	ACCESS: EXTERNAL
ATA 63: MAIN ROTOR DRIVE									
SSI 63-30-01/02/03/04/05: LH/RH FWD AND AFT STRUT ASSY, MAIN GEAR BOX STRUT FIXING BOLT									

© Copyright 2024 Leonardo S.p.a.

This document contains information that is confidential and proprietary to Leonardo S.p.a. ('the Company') and is supplied on the express condition that it may not be disclosed to any third party, or reproduced in whole or in part, or used for manufacture, or used for any purpose other than for which it is supplied, without the prior written consent of the Company. Every permitted disclosure, reproduction, adaptation or publication of this document in whole or in part and in any manner or form shall prominently contain this notice



AW189 Maintenance Review Board Report

189G0000M006

Issue V

Page 250 of 275

REVISION STATUS	MRB-R TASK NUMBER	TASK CODE	TASK TITLE	SOURCE	INTERVAL	APPLICABILITY		ZONE	ACCESS & REMARKS
						AW189	AW189ER		
	633001S-01	DI	DETAILED INSPECTION OF THE LH/RH FWD/AFT STRUT ASSEMBLIES AND BOLTED JOINTS	AD	6 YR	YES	YES	450 ; 470	ACCESS: 451A ; 471A ; 472A
	633001S-02	GVI	GENERAL VISUAL INSPECTION OF THE RH FWD STRUT ASSY FOR CONDITION.	AD	400 FH ; 1 YR	YES	YES	450	ACCESS: 451A
SSI 63-30-06/07: MAIN GEAR BOX LH/RH FWD BRACKET ASSY									
	633006S-01	DI	DETAILED INSPECTION OF THE LH/RH MAIN GEAR BOX (MGB) FWD BRACKETS INCLUDING VISIBLE PART OF SPHERICAL BEARINGS	ED ; CPCP	4 YR	YES	YES	450	ACCESS: 451A
	633006S-02	DI	DETAILED INSPECTION OF THE LH/RH MAIN GEAR BOX (MGB) FWD BRACKETS ANCHOR BOLTS (FWD) NOTE: TO BE ACCOMPLISHED AFTER 633006S-04	ED ; CPCP	8 YR	YES	YES	450	ACCESS: 451A ; 227B REMOVAL: ANCHOR BOLTS

© Copyright 2024 Leonardo S.p.a.

This document contains information that is confidential and proprietary to Leonardo S.p.a. ('the Company') and is supplied on the express condition that it may not be disclosed to any third party, or reproduced in whole or in part, or used for manufacture, or used for any purpose other than for which it is supplied, without the prior written consent of the Company. Every permitted disclosure, reproduction, adaptation or publication of this document in whole or in part and in any manner or form shall prominently contain this notice



AW189 Maintenance Review Board Report

189G0000M006

Issue V

Page 251 of 275

REVISION STATUS	MRB-R TASK NUMBER	TASK CODE	TASK TITLE	SOURCE	INTERVAL	APPLICABILITY		ZONE	ACCESS & REMARKS
						AW189	AW189ER		
	633006S-03	DI	DETAILED INSPECTION OF THE LH/RH MAIN GEAR BOX (MGB) FWD BRACKETS ANCHOR BOLTS (AFT) NOTE: TO BE ACCOMPLISHED AFTER 633006S-04	ED ; CPCP	4 YR	YES	YES	450	ACCESS: 451A ; 227B REMOVAL: ANCHOR BOLTS
	633006S-04	FC	FUNCTIONAL CHECK (TORQUE CHECK) OF THE LH/RH MAIN GEAR BOX (MGB) FWD BRACKETS ANCHOR BOLTS NOTE 1: TO BE ACCOMPLISHED BEFORE 633006S-02 AND / OR 633006S-03 NOTE 2: IDENTICAL TO 533302S-02	ED ; CPCP	3200 FH ; 4 YR	YES	YES	450	ACCESS: 451A ; 227B
SSI 63-30-08/09: MAIN GEAR BOX LH/RH REAR BRACKET ASSY									
	633008S-01	DI	DETAILED INSPECTION OF THE LH/RH MAIN GEAR BOX (MGB) REAR BRACKETS INCLUDING VISIBLE PART OF SPHERICAL BEARINGS	ED ; CPCP	4 YR	YES	YES	470	ACCESS: 451A ; 471A ; 472A REMOVAL: AIR INTAKE

© Copyright 2024 Leonardo S.p.a.

This document contains information that is confidential and proprietary to Leonardo S.p.a. ('the Company') and is supplied on the express condition that it may not be disclosed to any third party, or reproduced in whole or in part, or used for manufacture, or used for any purpose other than for which it is supplied, without the prior written consent of the Company. Every permitted disclosure, reproduction, adaptation or publication of this document in whole or in part and in any manner or form shall prominently contain this notice



AW189 Maintenance Review Board Report

189G0000M006

Issue V

Page 252 of 275

REVISION STATUS	MRB-R TASK NUMBER	TASK CODE	TASK TITLE	SOURCE	INTERVAL	APPLICABILITY		ZONE	ACCESS & REMARKS
						AW189	AW189ER		
	633008S-02	DI	DETAILED INSPECTION OF THE LH/RH MAIN GEAR BOX (MGB) REAR BRACKETS ANCHOR BOLTS NOTE: TO BE ACCOMPLISHED AFTER 633008S-03	ED ; CPCP	4 YR	YES	YES	470	ACCESS: 451A ; 227C ; 227D REMOVAL: AIR INTAKE ; BOLTS
	633008S-03	FC	FUNCTIONAL CHECK (TORQUE CHECK) OF THE LH/RH REAR MAIN GEAR BOX (MGB) BRACKETS ANCHOR BOLTS NOTE 1: TO BE ACCOMPLISHED BEFORE 633008S-02 NOTE 2: IDENTICAL TO 533302S-03	ED ; CPCP	3200 FH ; 4 YR	YES	YES	470	ACCESS: 451A ; 227C ; 227D REMOVAL: AIR INTAKE
SSI 63-30-10/11: ANTI-TORQUE BEAM ASSY AND BOLT									
	633010S-01	DI	DETAILED INSPECTION OF THE VISIBLE PARTS OF ANTI-TORQUE BEAM ASSY	AD ; ED ; CPCP	2 YR	YES	YES	470	ACCESS: 451A ; 227B

© Copyright 2024 Leonardo S.p.a.

This document contains information that is confidential and proprietary to Leonardo S.p.a. ('the Company') and is supplied on the express condition that it may not be disclosed to any third party, or reproduced in whole or in part, or used for manufacture, or used for any purpose other than for which it is supplied, without the prior written consent of the Company. Every permitted disclosure, reproduction, adaptation or publication of this document in whole or in part and in any manner or form shall prominently contain this notice



AW189 Maintenance Review Board Report

189G0000M006

Issue V

Page 253 of 275

REVISION STATUS	MRB-R TASK NUMBER	TASK CODE	TASK TITLE	SOURCE	INTERVAL	APPLICABILITY		ZONE	ACCESS & REMARKS
						AW189	AW189ER		
	633010S-02	FC	FUNCTIONAL CHECK (TORQUE CHECK) OF ANTI-TORQUE BEAM ANCHOR BOLTS NOTE: IDENTICAL TO 533302S-04	ED ; CPCP	3200 FH	YES	YES	470	ACCESS: 451A ; 227B
ATA 71: ENGINE INSTALLATION									
SSI 71-20-01/03: PORT ENGINE SUPPORT JOINT, STARBOARD ENGINE SUPPORT JOINT									
	712001S-01	DI	DETAILED INSPECTION OF THE VISIBLE PART OF THE PORT AND STBD ENGINE SUPPORT JOINT SPHERICAL BEARINGS NOTE: SHOULD BE ACCOMPLISHED IN CONJUNCTION WITH 712002S-01	ED ; CPCP	2 YR	WITH CT7-2E1 ENGINE INSTALLATION	WITH CT7-2E1 ENGINE INSTALLATION	460	ACCESS: 461A ; 463A
SSI 71-20-02/04: PORT ENGINE SUPPORT BRACKET, STARBOARD ENGINE SUPPORT BRACKET									

© Copyright 2024 Leonardo S.p.a.

This document contains information that is confidential and proprietary to Leonardo S.p.a. ('the Company') and is supplied on the express condition that it may not be disclosed to any third party, or reproduced in whole or in part, or used for manufacture, or used for any purpose other than for which it is supplied, without the prior written consent of the Company. Every permitted disclosure, reproduction, adaptation or publication of this document in whole or in part and in any manner or form shall prominently contain this notice



AW189 Maintenance Review Board Report

189G0000M006

Issue V

Page 254 of 275

REVISION STATUS	MRB-R TASK NUMBER	TASK CODE	TASK TITLE	SOURCE	INTERVAL	APPLICABILITY		ZONE	ACCESS & REMARKS
						AW189	AW189ER		
	712002S-01	DI	DETAILED INSPECTION OF THE VISIBLE PARTS OF PORT / STARBOARD ENGINE SUPPORT BRACKET SPHERICAL BEARINGS AND ENGINE SUPPORT BRACKETS ANCHOR BOLTED JOINT SEALING INTEGRITY NOTE: SHOULD BE ACCOMPLISHED IN CONJUNCTION WITH 712001S-01	ED ; CPCP	2 YR	YES	YES	460	ACCESS: 461A ; 463A
	712002S-02	DI	DETAILED INSPECTION OF THE PORT / STARBOARD ENGINE SUPPORT BRACKETS INSTALLATION FOR EVIDENCE OF FRETTING NOTE: IDENTICAL TO 533303S-02	ED ; CPCP	3200 FH	YES	YES	190 ; 460	ACCESS: 461A ; 463A ; 228A ; 228B ; 228C
SSI 71-20-05: PORT ENGINE SUPPORT BEAM ASSY, STARBOARD ENGINE SUPPORT BEAM ASSY									
	712005S-01	DI	DETAILED INSPECTION OF THE VISIBLE PARTS OF THE PORT AND STBD ENGINE SUPPORT BEAM SPHERICAL BEARINGS	ED ; CPCP	4 YR	WITH ANETO-1K ENGINE INSTALLATION	NO	460	ACCESS: 461A ; 463A

© Copyright 2024 Leonardo S.p.a.

This document contains information that is confidential and proprietary to Leonardo S.p.a. ('the Company') and is supplied on the express condition that it may not be disclosed to any third party, or reproduced in whole or in part, or used for manufacture, or used for any purpose other than for which it is supplied, without the prior written consent of the Company. Every permitted disclosure, reproduction, adaptation or publication of this document in whole or in part and in any manner or form shall prominently contain this notice



SECTION E - ZONAL INSPECTIONS

1. GENERAL

Zonal Inspections contained in this section constitute the minimum requirements for a Zonal Inspection Programme. To develop the programme described herein, the aircraft was subdivided by the manufacturer into zones based on consideration of location, content and access. Each zonal area was reviewed to determine the systems or structure components installed including any associated wiring, tubing, ducting, pulleys, quadrants, supports etc. The likelihood of deterioration of these components, including the effect of the operational environment, was also reviewed.

The Zonal Inspections Section contains a series of General Visual Inspection (GVI) tasks derived from a Standard Zonal and EZAP analysis. Detailed and special Detailed Inspections (DI's) are not contained in the Zonal Section.

In addition, the Zonal Inspections Section satisfies General Visual Inspection requirements derived from the Systems & Powerplant Analysis and accepted by Zonal working group.

The intent of these transferred tasks is satisfied by performing the zonal inspections at the defined intervals so they do not need to be itemized or included in the Systems & Powerplant section.

The list of System & Powerplant analysis tasks satisfied by Zonal GVI is presented in [Appendix 6](#).

For the zones that contain electrical wiring and have potential for presence of combustible material, the Enhanced Zonal Analysis is performed and permits the identification of standalone inspections (either General Visual Inspection or Detailed Inspection) as well as tasks to minimize the possibility of accumulation of combustible materials.

The application of this procedure ensures that appropriate attention is given to EWIS. The stand-alone tasks generated by the enhanced zonal analysis are presented in the System & Powerplant section, under ATA 20, with no failure effect category quoted.



Access to zones should normally be easily accomplished, not requiring the use of special tools

Normally, the inspection aids to be used are a flashlight and/or inspection mirror. The entire visible contents of the zone with appropriate access open must be inspected for obvious damage, security of installation, and general condition including corrosion and leaks.

“Inspection - Zonal” Definition is provided in [Appendix 4](#).

Zonal inspection requirements provided in this section are presented in sequence / order by ATA assigned zonal numbers. The following is a list of ATA Specification assigned zonal numbers for the major zones:

- 100 - Fuselage
- 200 – Cockpit and cabin
- 300 – Tail Unit
- 400 – Power Plant, transmission and Rotors

Each major zone is divided into major sub-zones and zones.

A general description of each zone is provided in [Appendix 2](#).



2. ZONAL INSPECTIONS SECTION RULES

- 1) Each zonal inspection shall include a General Visual Inspection (GVI) for general condition and security of the accessible systems and structure items contained in the defined zone or zones. This Zonal GVI task inspects:
 - Structures by looking for signs of accidental damage, corrosion and cracks, blockage of drainage and for general condition of fasteners.
 - Systems installations for proper attachment and security (components, split-pin/lock-wire, ducting, tubing, cable, leaks, chafing marks etc...).
 - EWIS for general condition and security (cracks, loose clamps, chafing, accumulation of combustible material etc...).
 - The general condition of any fairings, panels or other items which are removed/opened to gain access to a particular zone.
 - Visible L/HIRF protections for evident signs of deterioration or damage of electrical bonding elements.
- 2) The extent of a zonal inspection is defined by the access required and the instructions provided with the task.
- 3) The access information for each zone is intended to serve as a guide during the development of the Operator's maintenance programme.
- 4) Areas within a zone may require basic cleaning prior to performing the General Visual Inspection task.
- 5) Some zones may be inspected with different intervals based on different access requirements.
- 6) This section also includes tasks arising from the Enhanced Zonal Analysis Procedure (EZAP) and LHIRF which are consolidated in the Zonal Inspections Section. The source marker "EZAP" and "LHIRF" are used in these cases.



- 7) Due to differences between AW189 and AW189ER Zones and Access, while conducting zonal inspections the Operators are reminded to respect the Zonal boundaries defined in Appendix 2.1 and 2.2.



3. EXPLANATION OF ZONAL INSPECTIONS SECTION FORMAT

Detailed information concerning the format of the inspection requirements is presented in Table 5.

REV STATUS	MRB-R TASK REF	TASK CODE	TASK TITLE	SOURCE	INTERVAL	APPLICABILITY	ZONE	ACCESS & REMARKS
1	2	3	4	5	6	7	8	9

TABLE 5

1 – This column shows the revision status of each single Task Reference as follows:

- N: New Item
- R: Revised Item
- D: Deleted Item
- “ _ ” (blank): Unchanged Item

In the initial MRB Report this column will be blank. Revision status references will be added on subsequent revisions.

2 – This column indicates the Zonal task reference. It is composed of 9 symbols as follows:

This column indicates the Zonal task reference. It is composed of 9 symbols as follows:

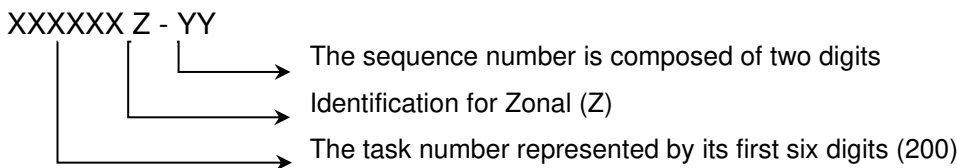

The task reference shall have same format of MSG-3 task but a Z shall be added after the first six digits

The first three digits of the task identification reference are fixed as 200 while the next three digits coincide with the Zonal number.



3 – This column provides GVI as the only possible task code.

4 – This column identifies the zone title and the description of task identified through the MSG3 Analysis process.

If the wording “NOTE” is used in other columns its explanation is reported in this column.

The meaning of MRBR Interval notes, such as NOTE_B, is provided in section B.

5 – This column specifies the source for task selection, following codes are used:

- ZIP, for tasks resulting from standard Zonal analysis
- MSI, for tasks arising from MSI and consolidated in the Zonal Section
- EZAP, for tasks arising from EZAP and consolidated in the Zonal Section
- L/HIRF, for tasks arising from LHIRF and consolidated in the Zonal Section
- FTS, for tasks related to Fuel Tank Safety (MSI 28-90-00, MSI 28-90-01)

Multiple sources are referred to when applicable.

6 – This column normally specifies the task intervals in terms of Calendar Time. Additional usage parameters like Rotorcraft Flight Hour (FH) could be used due to consolidation of tasks derived from another source.

In this case, the inspection is due when one of the limits, whichever comes first, is reached unless otherwise specified.

The Calendar Time is represented by means of following measure units:

- MH = Months
- YR = Years

The calendar interval is expressed using the highest available measure unit, for example:

- 12 MH is indicated as 1YR
- 18 MH remains unchanged.



7 – Applicability information is presented in 2 sub-columns, one for the AW189 and the other for AW189ER (for definition refer to Section A Para 1.1)

These applicability columns indicate the rotorcraft type and modification status, as necessary, to which the task is applicable.

Here after some examples of applicability information which might be provided for each sub-column:

- “YES”
- “NO”
- “with Rotor Brake kit ”;
- “S/N from xxxx to xxxx
- “post SB xxxx”
- “with CT7-2E1 engine installation”
- “with Aneto-1K engine installation”
- Others as applicable

8 – This column indicates the zone(s) where the GVI is to be performed. For the zone boundaries refer to Rotorcraft Zones and Access, [Appendix 2](#)
Multiple zones are reported when applicable.

9 – This column identifies, as applicable, access (normally by access panel number), rotorcraft configuration (flight controls position, doors opening, etc.) and removals required for the relevant inspection.



4. LIST OF TASKS

REVISION STATUS	MRB-R TASK NUMBER	TASK CODE	TASK TITLE	SOURCE	INTERVAL	APPLICABILITY		ZONE / SUB-ZONE	ACCESS & REMARKS
						AW189	AW189ER		
ZONE: 100, 200, 300, 400 FUSELAGE EXTERNAL									
	200100Z-01	GVI	GENERAL VISUAL INSPECTION OF ALL EXTERNAL AIRFRAME SURFACES INCLUDING THE ACCESS DOORS AND WINDOWS	ZIP ; MSI	1 YR	YES	YES	100 ; 200 ; 300 ; 400	EXTERNAL
ZONE: 111, 112, 114, 115, 116 NOSE FAIRING COMPARTMENT, LOWER NOSE AND NOSE AVIONICS BAYS (INTERNAL)									
	200111Z-01	GVI	GENERAL VISUAL INSPECTION OF THE LH/RH NOSE AVIONICS BAYS, THE LH/RH LOWER NOSE AND THE NOSE FAIRING COMPARTMENT INCLUDING THE 28VDC EXTERNAL POWER RECEPTACLE (INTERNAL)	ZIP; MSI; L/HIRF	1 YR	YES	YES	111 ; 112 ; 114 ; 115 ; 116	ACCESS: 111A ; 112A ; 113A; 114A ; 115A ; LH/RH LOWER NOSE ACCESS PANELS (WHEN CAMERA IS INSTALLED IT IS POSSIBLE TO UNMOUNT TURRET ALTERNATIVELY TO PANEL 113A)
ZONE: 113 NOSE LANDING GEAR COMPARTMENT									
	200113Z-01	GVI	GENERAL VISUAL INSPECTION OF THE NOSE LANDING GEAR COMPARTMENT	ZIP ; EZAP	1 YR	YES	YES	113	ACCESS: NLG EXTENDED ; NLG DOORS (IF INSTALLED)

© Copyright 2024 Leonardo S.p.a.

This document contains information that is confidential and proprietary to Leonardo S.p.a. ('the Company') and is supplied on the express condition that it may not be disclosed to any third party, or reproduced in whole or in part, or used for manufacture, or used for any purpose other than for which it is supplied, without the prior written consent of the Company. Every permitted disclosure, reproduction, adaptation or publication of this document in whole or in part and in any manner or form shall prominently contain this notice



AW189 Maintenance Review Board Report

189G0000M006

Issue V

Page 263 of 275

REVISION STATUS	MRB-R TASK NUMBER	TASK CODE	TASK TITLE	SOURCE	INTERVAL	APPLICABILITY		ZONE / SUB-ZONE	ACCESS & REMARKS
						AW189	AW189ER		
ZONE: 121, 122, 123 COCKPIT LOWER FUSELAGE (INTERNAL)									
	200121Z-01	GVI	GENERAL VISUAL INSPECTION OF THE COCKPIT LOWER FUSELAGE (INTERNAL) ACCESS NOTE: REMOVE THE STARBOARD AND PORT FORWARD FLOATATION ASSEMBLIES INSTEAD OF PANELS 121A AND 126A IF THE FLOATATION KIT IS INSTALLED.	ZIP ; L/HIRF	4 YR	YES	NO	121 ; 122 ; 123	ACCESS: 121A; 122A; 123A; 124A; 125A; 126A; NOTE
ZONE 121UB, 122UB, 123UB: COCKPIT LOWER FUSELAGE (INTERNAL)									
	200121Z-02	GVI	GENERAL VISUAL INSPECTION OF THE COCKPIT LOWER FUSELAGE (INTERNAL) ACCESS NOTE: REMOVE THE STARBOARD AND PORT FORWARD FLOATATION ASSEMBLIES INSTEAD OF PANELS 121A AND 126A IF THE FLOATATION KIT IS INSTALLED.	ZIP ; L/HIRF	4 YR	NO	YES	121UB ; 122UB ; 123UB	ACCESS: 121A ; 122A ; 123A ; 124A ; 125A ; 126A NOTE

© Copyright 2024 Leonardo S.p.a.

This document contains information that is confidential and proprietary to Leonardo S.p.a. ('the Company') and is supplied on the express condition that it may not be disclosed to any third party, or reproduced in whole or in part, or used for manufacture, or used for any purpose other than for which it is supplied, without the prior written consent of the Company. Every permitted disclosure, reproduction, adaptation or publication of this document in whole or in part and in any manner or form shall prominently contain this notice



AW189 Maintenance Review Board Report

189G0000M006

Issue V

Page 264 of 275

REVISION STATUS	MRB-R TASK NUMBER	TASK CODE	TASK TITLE	SOURCE	INTERVAL	APPLICABILITY		ZONE / SUB-ZONE	ACCESS & REMARKS
						AW189	AW189ER		
ZONE: 124 NOSE LANDING GEAR RETRACTION ACTUATOR COMPARTMENT (INTERNAL)									
	200124Z-01	GVI	GENERAL VISUAL INSPECTION OF THE NOSE LANDING GEAR (NLG) RETRACTION ACTUATOR COMPARTMENT	ZIP ; EZAP	2 YR	YES	YES	124	ACCESS: 213A ; 217A (OR 217B) ; NLG EXTENDED ; INTERSEAT CONSOLE EXTENSION LATERAL ACCESS PANELS (OR APPROPRIATE CONTENTS OF THE EXTENSION) (IF INSTALLED)
ZONE 125UB, 127UB, 128UB: COCKPIT UNDERBELLY FUSELAGE (INTERNAL)									
	200125Z-01	GVI	GENERAL VISUAL INSPECTION OF THE COCKPIT UNDERBELLY FUSELAGE (INTERNAL)	ZIP ; L/HIRF	1 YR	NO	YES	125UB ; 127UB ; 128UB	ACCESS: 127A ; 127B ; 129A ; 129B ; 128A
ZONE: 130, 140 FORWARD AND CENTER CABIN LOWER FUSELAGE (INTERNAL)									
	200130Z-01	GVI	GENERAL VISUAL INSPECTION OF THE FORWARD AND CENTER CABIN LOWER FUSELAGE (INTERNAL) ACCESS NOTE: AUXILIARY FUEL TANKS TO BE DISPLACED (IF INSTALLED)	ZIP ; L/HIRF ; FTS	4 YR	YES	NO	131 ; 132 ; 134 ; 141 ; 142 ; 145 ; 146	ACCESS: 221A ; 222A ; 223A ; 132A ; 133A ; 143A ; 144A ; 131A ; 134A ; 145D (IF INSTALLED); LH/RH FWD AUX FUEL TANK COVER SUMP ASSY ; NOTE REMOVAL: CABIN SEATS

© Copyright 2024 Leonardo S.p.a.

This document contains information that is confidential and proprietary to Leonardo S.p.a. ('the Company') and is supplied on the express condition that it may not be disclosed to any third party, or reproduced in whole or in part, or used for manufacture, or used for any purpose other than for which it is supplied, without the prior written consent of the Company. Every permitted disclosure, reproduction, adaptation or publication of this document in whole or in part and in any manner or form shall prominently contain this notice



AW189 Maintenance Review Board Report

189G0000M006

Issue V

Page 265 of 275

REVISION STATUS	MRB-R TASK NUMBER	TASK CODE	TASK TITLE	SOURCE	INTERVAL	APPLICABILITY		ZONE / SUB-ZONE	ACCESS & REMARKS
						AW189	AW189ER		
ZONE 131UB, 132UB, 136UB, 137UB, 141UB, 142UB, 145UB, 146UB: LOWER AND UNDERBELLY FUSELAGE SIDES									
	200131Z-01	GVI	GENERAL VISUAL INSPECTION OF THE LOWER AND UNDERBELLY FUSELAGE SIDES (INTERNAL)	ZIP ; L/HIRF	6 YR	NO	YES	131UB ;132UB ; 136UB ; 137UB ; 141UB ; 142UB ; 145UB ; 146UB	ACCESS: 221C ; 222B ; 223D ; 221G ; 222F ; 223F ; 136A ; 146A ; 146B ; 137A ; 145A ; 145B
ZONE 134UB, 143UB: CENTER CABIN LOWER FUSELAGE									
	200134Z-01	GVI	GENERAL VISUAL INSPECTION OF THE CENTRE CABIN LOWER FUSELAGE (INTERNAL)	ZIP ; L/HIRF	2 YR	NO	YES	134UB ; 143UB	ACCESS: 221E ; 222D ; 223E REMOVAL: CABIN SEAT
ZONE 135UB, 138UB, 139UB: UNDERBELLY FUEL TANK COMPARTMENTS									
	200135Z-01	GVI	GENERAL VISUAL INSPECTION OF UNDERBELLY FUEL COMPARTMENTS INCLUDING INTERNAL AREA OF THE FUEL TANKS ACCESS NOTE: FUEL TANKS TO BE DISPLACED.	ZIP ; L/HIRF ; FTS	4 YR	NO	YES	135UB ; 138UB ; 139UB	ACCESS: 222E ; 222C ; 138B,148C, 148D ; 139B ; 147D ; 147E ; 139A ; 147A ; 138A ; 148A ; 135A ; 149B ; 149D ; 135B REMOVAL: CABIN SEATS

© Copyright 2024 Leonardo S.p.a.

This document contains information that is confidential and proprietary to Leonardo S.p.a. ('the Company') and is supplied on the express condition that it may not be disclosed to any third party, or reproduced in whole or in part, or used for manufacture, or used for any purpose other than for which it is supplied, without the prior written consent of the Company. Every permitted disclosure, reproduction, adaptation or publication of this document in whole or in part and in any manner or form shall prominently contain this notice



AW189 Maintenance Review Board Report

189G0000M006

Issue V

Page 266 of 275

REVISION STATUS	MRB-R TASK NUMBER	TASK CODE	TASK TITLE	SOURCE	INTERVAL	APPLICABILITY		ZONE / SUB-ZONE	ACCESS & REMARKS
						AW189	AW189ER		
ZONE 147UB, 148UB: UNDERBELLY FUEL TANKS LH/RH HOSE COMPARTMENT									
	200147Z-01	GVI	GENERAL VISUAL INSPECTION OF THE UNDERBELLY FUEL TANK LH/RH HOSE COMPARTMENTS (INTERNAL)	ZIP ; L/HIRF	1 YR	NO	YES	147UB ; 148UB	(FROM ABOVE) ACCESS: 223E ; REMOVAL: CABIN SEATS OR (FROM BELOW) ACCESS: 147B ; 148B
ZONE 149UB: CENTER CABIN FUSELAGE CARGO HOOK COMPARTMENT									
	200149Z-01	GVI	GENERAL VISUAL INSPECTION OF THE CENTRE CABIN FUSELAGE CARGO HOOK COMPARTMENT (INTERNAL)	ZIP	1 YR	NO	YES	149	ACCESS: 149C
ZONE 151, 152: LEFT AND RIGHT REAR FUSELAGE (INTERNAL)									
	200151Z-01	GVI	GENERAL VISUAL INSPECTION OF FUEL COMPARTMENT (INCLUDING THE CENTRAL AUXILIARY FUEL TANK IF INSTALLED), INCLUDING INTERNAL AREA OF THE FUEL TANKS ACCESS NOTE: FUEL TANKS TO BE DISPLACED.	ZIP ; L/HIRF ; FTS	6 YR	YES	NO	151 ; 152	ACCESS: 158A ; 158B ; 158C ; 158D ; 158G ; 158H ; 229A ; 229B ; 229C ; 229D ; 229E, 229F ; 229G ; 229H ; 229N ; 229L ; 229M ; ENGINE/APU SOV'S AND XFEED VALVE COVERS, PRESSURE REFUEL/DEFUEL CAP OPEN ; 153A, 153B ; 154A ; 154B ; 155A ; 159A ; 159C ; 159F ; 159B ; 159E ; 159G ; NOTE REMOVAL: CABIN SEATS ABOVE MAIN FUEL TANK

© Copyright 2024 Leonardo S.p.a.

This document contains information that is confidential and proprietary to Leonardo S.p.a. ('the Company') and is supplied on the express condition that it may not be disclosed to any third party, or reproduced in whole or in part, or used for manufacture, or used for any purpose other than for which it is supplied, without the prior written consent of the Company. Every permitted disclosure, reproduction, adaptation or publication of this document in whole or in part and in any manner or form shall prominently contain this notice



AW189 Maintenance Review Board Report

189G0000M006

Issue V

Page 267 of 275

REVISION STATUS	MRB-R TASK NUMBER	TASK CODE	TASK TITLE	SOURCE	INTERVAL	APPLICABILITY		ZONE / SUB-ZONE	ACCESS & REMARKS
						AW189	AW189ER		
ZONE 151UB, 152UB, 157UB, 158UB, 159UB: LEFT AND RIGHT FUEL COMPARTMENT AND LOWER COWLINGS									
	200151Z-02	GVI	GENERAL VISUAL INSPECTION OF THE LEFT AND RIGHT FUEL TANK COMPARTMENTS AND LOWER COWLINGS COMPARTMENTS INCLUDING INSIDE AREA OF THE FUEL TANKS (INTERNAL) ACCESS NOTE: FUEL TANKS TO BE DISPLACED	ZIP ; L/HIRF ; FTS	6 YR	NO	YES	151UB ; 152UB ; 157UB ; 158UB ; 159UB	ACCESS: 158A ; 158B ; 158C ; 158D ; 158G ; 158H ; 229A ; 229B ; 229C ; 229D ; 229E ; 229F ; 229G ; 229H ; 229N ; 229L ; 229M ; ENGINE/APU SoV's AND XFEED VALVE COVERS ; PRESSURE REFUEL / DEFUEL CAP OPEN ; 153A ; 153B ; 154A ; 154B ; 155A ; 159A ; 159C ; 159F ; 159B ; 159E ; 159G ; NOTE REMOVAL: CABIN SEATS ABOVE MAIN FUEL TANK
ZONE: 153, 154, 155, 156 LH/RH SPONSONS AND LH/RH MAIN LANDING GEAR COMPARTMENT (INTERNAL)									
	200153Z-01	GVI	GENERAL VISUAL INSPECTION OF THE MAIN LANDING GEAR (MLG) COMPARTMENTS AND SPONSONS	ZIP ; EZAP ; L/HIRF	4 YR	YES	YES	153 ; 154 ; 155 ; 156	ACCESS: 151D ; 152D ; 156A ; 157A

© Copyright 2024 Leonardo S.p.a.

This document contains information that is confidential and proprietary to Leonardo S.p.a. ('the Company') and is supplied on the express condition that it may not be disclosed to any third party, or reproduced in whole or in part, or used for manufacture, or used for any purpose other than for which it is supplied, without the prior written consent of the Company. Every permitted disclosure, reproduction, adaptation or publication of this document in whole or in part and in any manner or form shall prominently contain this notice



AW189 Maintenance Review Board Report

189G0000M006

Issue V

Page 268 of 275

REVISION STATUS	MRB-R TASK NUMBER	TASK CODE	TASK TITLE	SOURCE	INTERVAL	APPLICABILITY		ZONE / SUB-ZONE	ACCESS & REMARKS
						AW189	AW189ER		
ZONE: 160 REAR FUSELAGE (INTERNAL)									
	200160Z-01	GVI	GENERAL VISUAL INSPECTION OF LEFT AND RIGHT REAR LOWER AND UPPER FUSELAGE INCLUDING THE EXTERNAL POWER RECEPTACLE (INTERNAL) ACCESS NOTE: WITH FLOATATION KIT INSTALLED, AFT PORT AND STARBOARD FLOATATION ASSEMBLIES REMOVED INSTEAD OF 163A ; 164A	ZIP; MSI; L/HIRF	2 YR	WITHOUT FIPS KIT	WITHOUT FIPS KIT	160	ACCESS: 161A ; 162A ; 163A ; 164A ; 168A 169A ; 165D ; 166A ; 167A ; 165G ; 165B ; NOTE REMOVAL: LH/RH REAR LOWER FUSELAGE VENTILATION PIPES COVER ASSEMBLIES, LINERS AND LH/RH REAR FUSELAGE DOOR LATCH MECHANISM COVER, HEAVY DUTY BAGGAGE COMPARTMENT KIT (if installed)
	200160Z-02	GVI	GENERAL VISUAL INSPECTION OF LEFT AND RIGHT REAR LOWER AND UPPER FUSELAGE INCLUDING THE EXTERNAL POWER RECEPTACLE (INTERNAL) ACCESS NOTE: WITH FLOATATION KIT INSTALLED, AFT PORT AND STARBOARD FLOATATION ASSEMBLIES REMOVED INSTEAD OF 163A ; 164A	ZIP; MSI; L/HIRF	1 YR	WITH FIPS KIT	WITH FIPS KIT	160	ACCESS: 161A ; 162A ; 163A ; 164A ; 168A 169A ; 165D ; 166A ; 167A ; 165G ; 165B ; NOTE REMOVAL: LH/RH REAR LOWER FUSELAGE VENTILATION PIPES COVER ASSEMBLIES, LINERS AND LH/RH REAR FUSELAGE DOOR LATCH MECHANISM COVER, HEAVY DUTY BAGGAGE COMPARTMENT KIT (if installed)

© Copyright 2024 Leonardo S.p.a.

This document contains information that is confidential and proprietary to Leonardo S.p.a. ('the Company') and is supplied on the express condition that it may not be disclosed to any third party, or reproduced in whole or in part, or used for manufacture, or used for any purpose other than for which it is supplied, without the prior written consent of the Company. Every permitted disclosure, reproduction, adaptation or publication of this document in whole or in part and in any manner or form shall prominently contain this notice



AW189 Maintenance Review Board Report

189G0000M006

Issue V

Page 269 of 275

REVISION STATUS	MRB-R TASK NUMBER	TASK CODE	TASK TITLE	SOURCE	INTERVAL	APPLICABILITY		ZONE / SUB-ZONE	ACCESS & REMARKS
						AW189	AW189ER		
ZONE: 170, 180, 190 CABIN ROOF AND UPPER FUSELAGE (INTERNAL)									
	200170Z-01	GVI	GENERAL VISUAL INSPECTION OF CABIN ROOF AND UPPER FUSELAGE (INTERNAL)	ZIP ; L/HIRF	4 YR	YES	YES	170 ; 180 ; 190	ACCESS: 226A ; 226B ; 226C ; 226D ; 226E ; 226F ; 226G ; 226H ; 226J ; 226K ; 227A ; 227B ; 227C ; 227D ; 227E ; 227F ; 227G ; 227H ; 227J ; 227K ; 227L ; 227M ; 227N ; 227P ; 227Q ; 228A ; 228B ; 228C ; 229J ; 229K
ZONE: 210 COCKPIT INTERNAL									
	200210Z-01	GVI	GENERAL VISUAL INSPECTION OF THE INTERNAL COCKPIT AREA	ZIP; MSI; L/HIRF	2 YR	YES	YES	210	ACCESS: 213 ; 214 ; 217A ; 217B ; 217C ; ALL COCKPIT LINERS ; SEATS MOVED IN FULL AFT & FULL FORWARD POSITIONS ; INTERSEAT CONSOLE EXTENSION LATERAL ACCESS PANELS (IF INSTALLED). REMOVAL: C/B PANEL AND GLARE SHIELD (INCLUDING ECS DIFFUSER COVERS)

© Copyright 2024 Leonardo S.p.a.

This document contains information that is confidential and proprietary to Leonardo S.p.a. ('the Company') and is supplied on the express condition that it may not be disclosed to any third party, or reproduced in whole or in part, or used for manufacture, or used for any purpose other than for which it is supplied, without the prior written consent of the Company. Every permitted disclosure, reproduction, adaptation or publication of this document in whole or in part and in any manner or form shall prominently contain this notice



AW189 Maintenance Review Board Report

189G0000M006

Issue V

Page 270 of 275

REVISION STATUS	MRB-R TASK NUMBER	TASK CODE	TASK TITLE	SOURCE	INTERVAL	APPLICABILITY		ZONE / SUB-ZONE	ACCESS & REMARKS
						AW189	AW189ER		
ZONE: 220 CABIN (INTERNAL)									
	200220Z-01	GVI	GENERAL VISUAL INSPECTION OF THE PASSENGER CABIN INCLUDING THE CABIN DOORS (INTERNAL)	ZIP ; EZAP	8 YR	YES	YES	220	<p>ACCESS: 224A ; 224B ; 224C ; 224D ; 225A ; 225B ; 225C ; 225D ; 225E ; 225 & 226 (TO BE CLOSED DURING INSPECTION)</p> <p>REMOVAL: CABIN SEATS AND LINERS (INCLUDING THE NOISE ABSORBING CUSHIONS IF INSTALLED), BAGGAGE COMPARTMENT BOXES IN CABIN (IF INSTALLED) AND SEA TRAY (IF INSTALLED)</p>
	200220Z-02	GVI	GENERAL VISUAL INSPECTION OF THE PASSENGER CABIN INCLUDING THE CABIN DOORS (INTERNAL)	ZIP; MSI	2 YR	WITHOUT SEA TRAY	WITHOUT SEA TRAY	220	<p>ACCESS: 225 & 226 (TO BE CLOSED DURING INSPECTION)</p>
	200220Z-03	GVI	GENERAL VISUAL INSPECTION OF THE PASSENGER CABIN INCLUDING THE CABIN DOORS (INTERNAL)	ZIP; MSI	1 YR	WITH SEA TRAY	WITH SEA TRAY	220	<p>ACCESS: 225 & 226 (TO BE CLOSED DURING INSPECTION)</p> <p>REMOVAL: CABIN SEATS AND SEA TRAY</p>

© Copyright 2024 Leonardo S.p.a.

This document contains information that is confidential and proprietary to Leonardo S.p.a. ('the Company') and is supplied on the express condition that it may not be disclosed to any third party, or reproduced in whole or in part, or used for manufacture, or used for any purpose other than for which it is supplied, without the prior written consent of the Company. Every permitted disclosure, reproduction, adaptation or publication of this document in whole or in part and in any manner or form shall prominently contain this notice



AW189 Maintenance Review Board Report

189G0000M006

Issue V

Page 271 of 275

REVISION STATUS	MRB-R TASK NUMBER	TASK CODE	TASK TITLE	SOURCE	INTERVAL	APPLICABILITY		ZONE / SUB-ZONE	ACCESS & REMARKS
						AW189	AW189ER		
ZONE: 310, 320 TAIL CONE AND TAIL PYLON (INTERNAL)									
	200310Z-01	GVI	GENERAL VISUAL INSPECTION OF THE INTERNAL TAIL CONE AND TAIL PYLON AREA	ZIP ; L/HIRF ; EZAP	2 YR	YES	YES	310 ; 320	ACCESS: 311A, 493A, 322A, 321A
ZONE: 410, 420, 430, 440 MAIN AND TAIL ROTOR HEAD AND BLADES									
	200400Z-01	GVI	GENERAL VISUAL INSPECTION OF THE MAIN ROTOR AND THE TAIL ROTOR ASSEMBLIES INCLUDING ROTOR BLADES	ZIP	1 YR	YES	YES	400	ACCESS: 451A
ZONE: 450 FORWARD FAIRING COMPARTMENT INTERNAL									
	200450Z-01	GVI	GENERAL VISUAL INSPECTION OF THE FORWARD FAIRING COMPARTMENT (INTERNAL)	ZIP; MSI; L/HIRF	2 YR	YES	YES	450	REMOVAL: 451A

© Copyright 2024 Leonardo S.p.a.

This document contains information that is confidential and proprietary to Leonardo S.p.a. ('the Company') and is supplied on the express condition that it may not be disclosed to any third party, or reproduced in whole or in part, or used for manufacture, or used for any purpose other than for which it is supplied, without the prior written consent of the Company. Every permitted disclosure, reproduction, adaptation or publication of this document in whole or in part and in any manner or form shall prominently contain this notice



AW189 Maintenance Review Board Report

189G0000M006

Issue V

Page 272 of 275

REVISION STATUS	MRB-R TASK NUMBER	TASK CODE	TASK TITLE	SOURCE	INTERVAL	APPLICABILITY		ZONE / SUB-ZONE	ACCESS & REMARKS
						AW189	AW189ER		
ZONE 460, 480: ENGINE AND EXHAUST FAIRING COMPARTMENTS INTERNAL									
	200460Z-01	GVI	GENERAL VISUAL INSPECTION OF THE ENGINE COMPARTMENTS, THE EXHAUSTS FAIRING COMPARTMENT AND THE AREA BELOW APU COMPARTMENT AS FAR AS VISIBLE (INTERNAL)	ZIP; MSI; L/HIRF	6 MH	YES	YES	460 ; 480	ACCESS: 461A ; 462A ; 463A ; 481A
ZONE: 470 INTAKE COMPARTMENTS INTERNAL									
	200470Z-01	GVI	GENERAL VISUAL INSPECTION OF THE ENGINE AIR INTAKE COMPARTMENTS, INCLUDING THE ZONE BETWEEN THE ENGINE AIR INTAKES (INTERNAL)	ZIP; MSI; L/HIRF	1 YR	YES	YES	470	ACCESS: 451A ; 471A ; 472A
ZONE: 490 DRIVE SHAFT COMPARTMENT INTERNAL									
	200490Z-01	GVI	GENERAL VISUAL INSPECTION OF THE INTERNAL DRIVE SHAFT COMPARTMENT	ZIP ; L/HIRF ; EZAP	2 YR	YES	YES	490	REMOVAL: DRIVE SHAFT COMPARTMENT COWLINGS AND TGB FAIRING ASSY
ZONE: 700 LANDING GEAR									
	200700Z-01	GVI	GENERAL VISUAL INSPECTION OF THE NOSE AND MAIN LANDING GEAR	ZIP ; EZAP; L/HIRF	2 YR	YES	YES	700	ACCESS: 156A ; 157A ; NLG/MLG EXTENDED

© Copyright 2024 Leonardo S.p.a.

This document contains information that is confidential and proprietary to Leonardo S.p.a. ('the Company') and is supplied on the express condition that it may not be disclosed to any third party, or reproduced in whole or in part, or used for manufacture, or used for any purpose other than for which it is supplied, without the prior written consent of the Company. Every permitted disclosure, reproduction, adaptation or publication of this document in whole or in part and in any manner or form shall prominently contain this notice



SECTION F - LIGHTNING/HIRF (L/HIRF) & FUEL TANK SAFETY (FTS) INTERFACES

1 LIGHTNING / HIRF

The intent of Lightning/High Intensity Radiated Field (L/HIRF) related scheduled maintenance is to reduce the possibility that a single failure cause or event (such as a lightning strike), and the occurrence of a common failure cause (such as AD or ED) across redundant channels of L/HIRF Protection Components, could impact rotorcraft airworthiness.

Maintenance tasks for L/HIRF Protection Components have been developed in support of the rotorcraft type certification and MRB Report development. L/HIRF analysis has been based on data defining systems critical to L/HIRF to be analysed (A and B level according to 189G9850R001 or others applicable Safety Documents addressing CS 29.1309 requirements).

Using a logic type analysis, based on the consequences of the protection system's failure, the type of scheduled maintenance task and required interval of the task has been determined. Common mode degradation in a localized area has been considered in the L/HIRF analysis process.

1.1 INTERNAL LINE REPLACEABLE UNIT (LRU) L/HIRF PROTECTION COMPONENTS

L/HIRF protection devices such as filter pin connectors, discrete filter capacitors and transient protection devices (tranzorbs) are installed within LRU's.

The Rotorcraft manufacturer together with the LRU's manufacturer establish a maintenance philosophy for the LRU that ensures the continued effectiveness of L/HIRF protective features.

Therefore scheduled maintenance for internal LRU L/HIRF protection devices is not part of MSG-3 Analysis and MRB Report.



1.2 EXTERNAL ON ROTORCRAFT L/HIRF PROTECTION COMPONENTS

All L/HIRF protection components on the rotorcraft (i.e. any protection not within an LRU) whose failures were identified during L/HIRF certification as having an adverse effect on safety have been analysed during MSG3 analysis.

Scheduled maintenance requirements for these external L/HIRF protection components are presented under section C (ATA chapter 20) and section E of this MRB Report with “L/HIRF” marker in the source column.

2 FUEL TANK SAFETY (FTS)

Latent failure which in combination with one or more specific failures or events, may result in the occurrence of fuel tank ignition (i.e. occurrence of a Catastrophic Failure Condition) have been addressed by a CMR (if any) see [Appendix 1](#).

Latent failure which in combination with one specific failure or event, may result in the degradation of the of fuel tank ignition prevention capability have been addressed by MSG-3 analysis.

All ignition source prevention features of fuel tank systems (as bonding leads, fuel pump canisters, electrical wiring and connectors, heat shield blankets, thermal shields, etc) are identified and addressed in a dedicated MSI dossier, MSI 28-90-00 / MSI 28-90-01. All associated scheduled maintenance requirements are reported in Section C and Section E of this report with “FTS” marker in the source column.



SECTION G - REQUIREMENTS FOR U.S. OPERATORS

This section details the additional or specific requirements which must be embodied in the previous sections of this MRBR in order to provide the initial maintenance requirements acceptable to the Federal Aviation Administration (FAA) Maintenance Review Board (MRB) for the AW189 rotorcraft operated by United States certificated operators.

These additional/specific requirements are listed as follows under the related MRBR section heading:

➤ SECTION B

The paragraph 5 does not apply to U.S. operators

- Failure Effect Category (FEC) 5 or 8 safety tasks cannot be deleted or escalated without the approval of the MRB chairperson. Additionally, those Category 5 and 8 tasks involving either fuel tank safety (FTS) or the electrical wiring interconnection system (EWIS)/enhanced zonal analysis procedure (EZAP) programs may not be deleted or escalated without approval from the Aircraft Certification Office (ACO).



APPENDIX 1 - AIRWORTHINESS LIMITATIONS SECTION

1.1 RETIREMENT LIFE

Refer to Air vehicle Maintenance Planning Information (AMPI) Chapter 4 Section 10.

1.2 MANDATORY INSPECTIONS

Refer to Air vehicle Maintenance Planning Information (AMPI) Chapter 4 Section 20.

1.3 CMRs

Refer to Air vehicle Maintenance Planning Information (AMPI) Chapter 4 Section 30

NOTE: Mandatory requirements in relation to Fuel Tank Safety are included in CMR section.



APPENDIX 2 ROTORCRAFT ZONES AND ACCESS

1. AW189

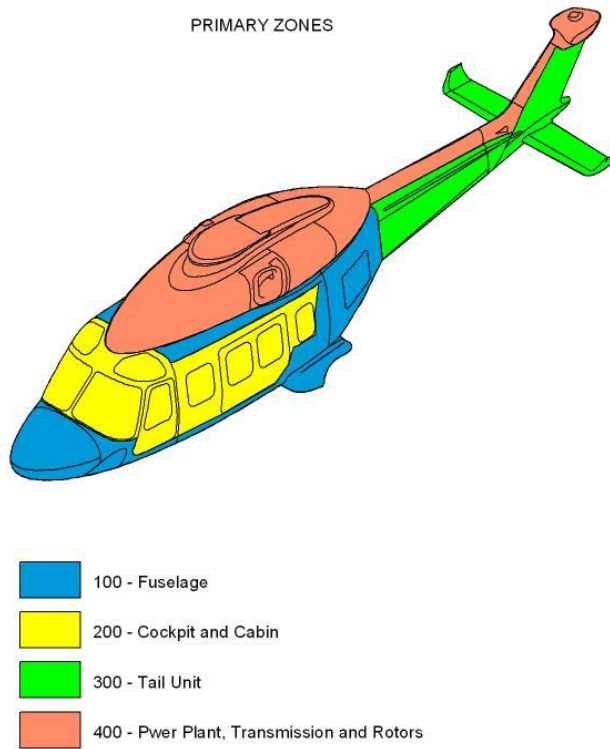



- 100: Fuselage
- 200: Cockpit and Cabin
- 300: Tail Unit
- 400: Power Plant, Transmissions and Rotors
- 700: Landing Gear

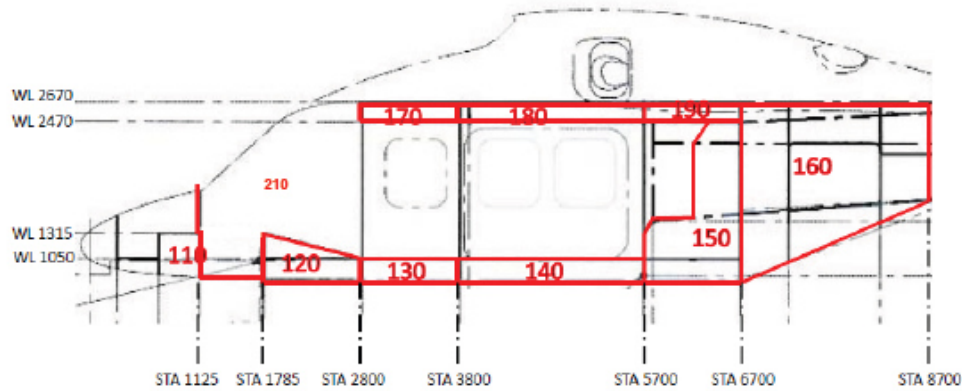

- 110: Nose**
- 120: Cockpit Lower Fuselage**
- 130: Forward Cabin Lower Fuselage**
- 140: Center Cabin Lower Fuselage**
- 150: Fuel Compartment**
- 160: Rear Fuselage**
- 170: Forward Cabin Roof and Upper Fuselage**
- 180: Center Cabin Roof and Upper Fuselage**
- 190: Aft Cabin Roof and Upper Fuselage**
- 210: Cockpit**

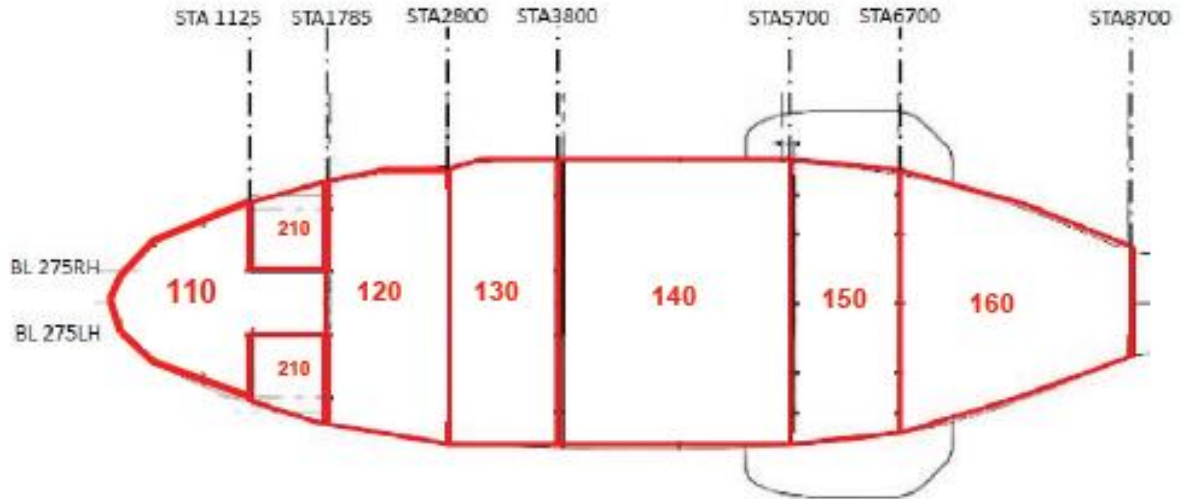

- 110: Nose**
- 120: Cockpit Lower Fuselage**
- 130: Forward Cabin Lower Fuselage**
- 140: Center Cabin Lower Fuselage**
- 150: Fuel Compartment**
- 160: Rear Fuselage**
- 210: Cockpit**

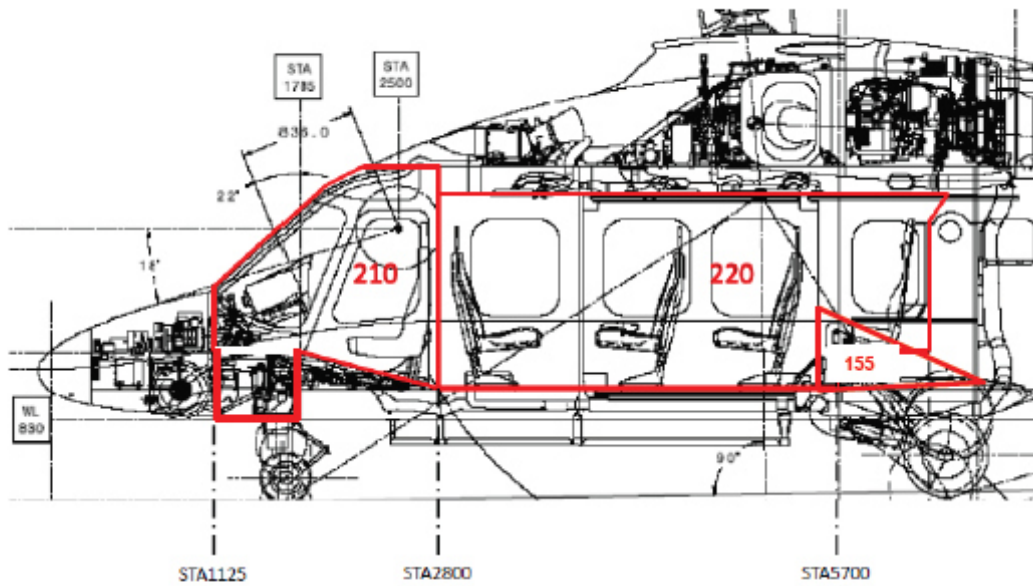

- 155: LH MLG Compartment
- 156: RH MLG Compartment
- 210: Cockpit
- 220: Cabin
- 710: Nose Landing Gear
- 720: RH Main Landing Gear
- 730: LH Main Landing Gear

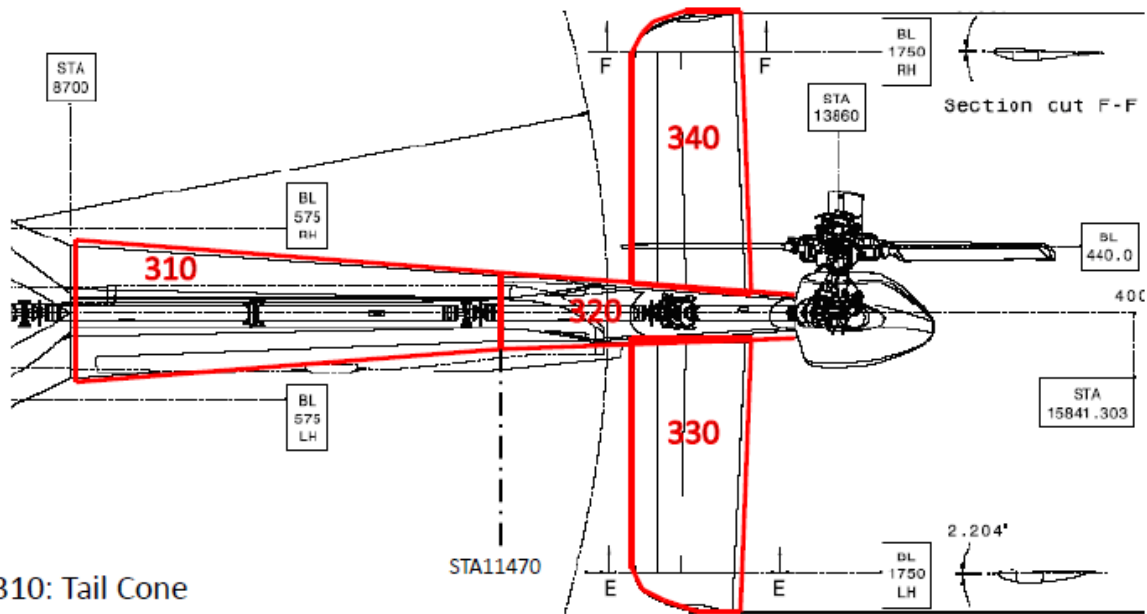

- 310: Tail Cone
- 320: Tail Pylon
- 330: LH Tailplane
- 340: RH Tailplane

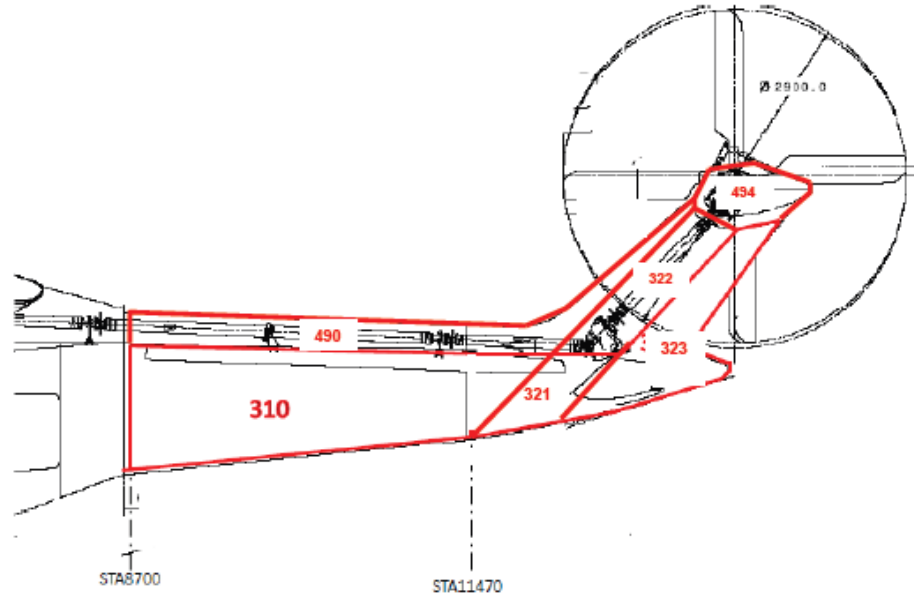

- 310: Tail Cone
- 320: Tail Pylon
- 321: Forward Lower Tail Pylon
- 322: Forward Upper Tail Pylon
- 323: Rear Tail Pylon
- 494: TGB Compartment

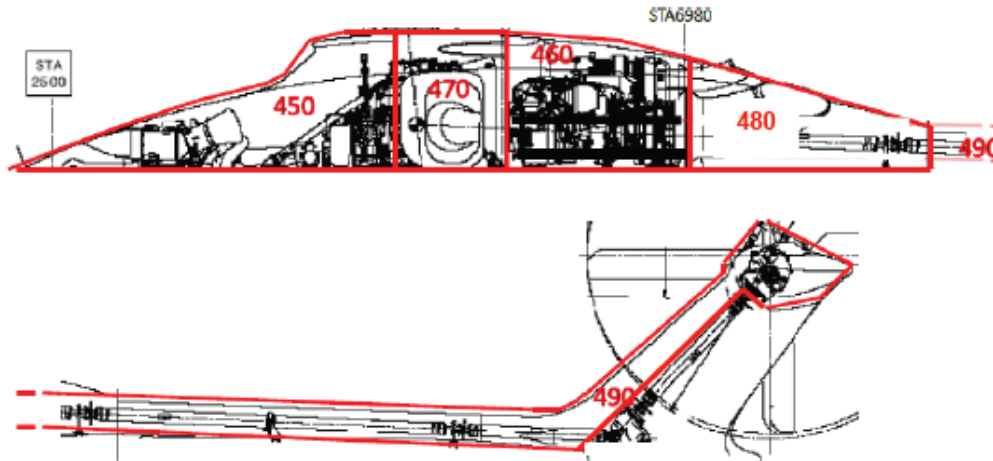

- 450: Forward Fairing Compartment
- 460: Engine Compartments
- 470: Intake Compartments
- 480: Exhaust Fairing Compartment
- 490: Drive Shaft Compartment

- 410: Main Rotor Head *(not showed in this picture)*
- 420: Main Rotor Blades *(not showed in this picture)*
- 430: Tail Rotor Head *(not showed in this picture)*
- 440: Tail Rotor Blades *(not showed in this picture)*

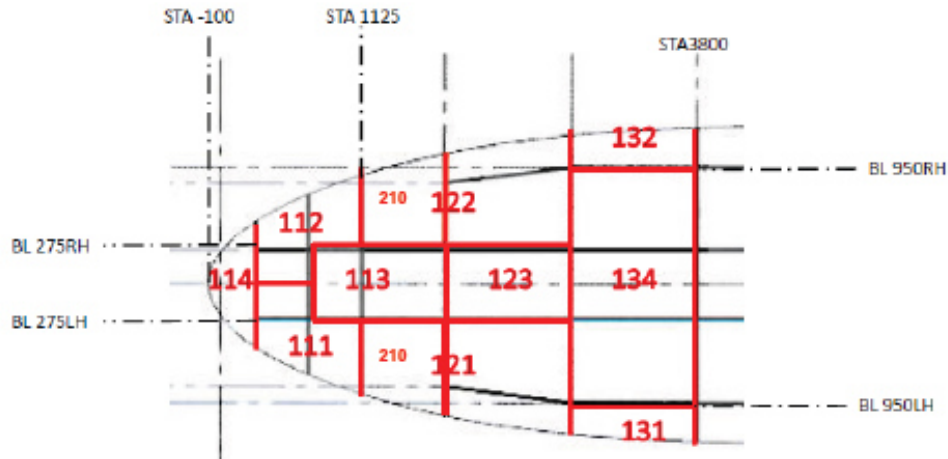

- 111: LH Lower Nose**
- 112: RH Lower Nose**
- 113: NLG Compartment**
- 114: Nose Fairing Compartment**
- 121: LH Cockpit Lower Fuselage**
- 122: RH Cockpit Lower Fuselage**
- 123: Center Cockpit Lower Fuselage**
- 131: LH Forward Cabin Lower Fuselage**
- 132: RH Forward Cabin Lower Fuselage**
- 134: Center Forward Cabin Lower Fuselage**
- 210: Cockpit**

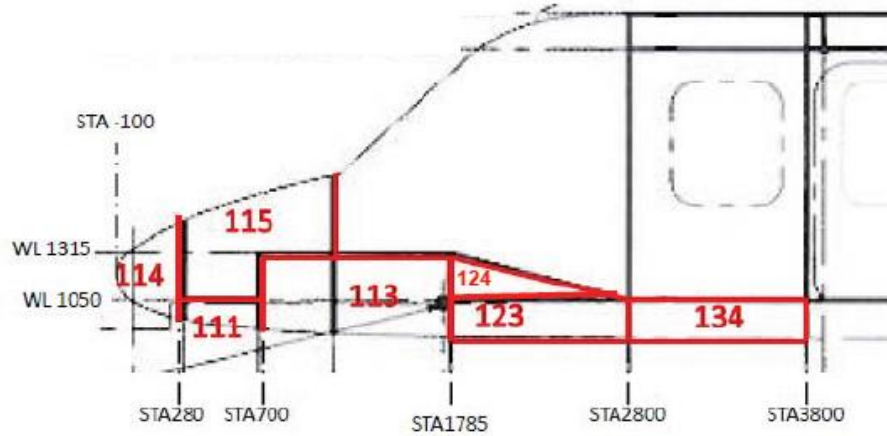

- 111:** LH Lower Nose
- 112:** RH Lower Nose (*not showed in this picture*)
- 113:** NLG Compartment
- 114:** Nose Fairing Compartment
- 115:** LH Nose Avionics Bay
- 116:** RH Nose Avionics Bay (*not showed in this picture*)
- 123:** Center Cockpit Lower Fuselage
- 124:** NLG Retraction Actuator Compartment
- 134:** Center Forward Cabin Lower Fuselage

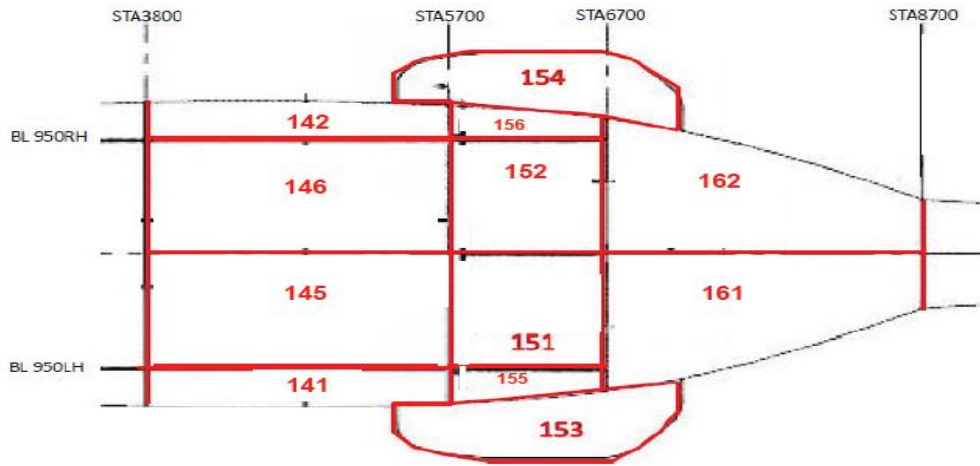

- 141:** LH Center Cabin Lower Fuselage Side
- 142:** RH Center Cabin Lower Fuselage Side
- 145:** LH Center Cabin Lower Fuselage
- 146:** RH Center Lower Fuselage
- 151:** LH Fuel Compartment
- 152:** RH Fuel Compartment
- 153:** LH Sponson
- 154:** RH Sponson
- 155:** LH MLG Compartment
- 156:** RH MLG Compartment
- 161:** RH Rear Lower Fuselage
- 162:** RH Rear Lower Fuselage

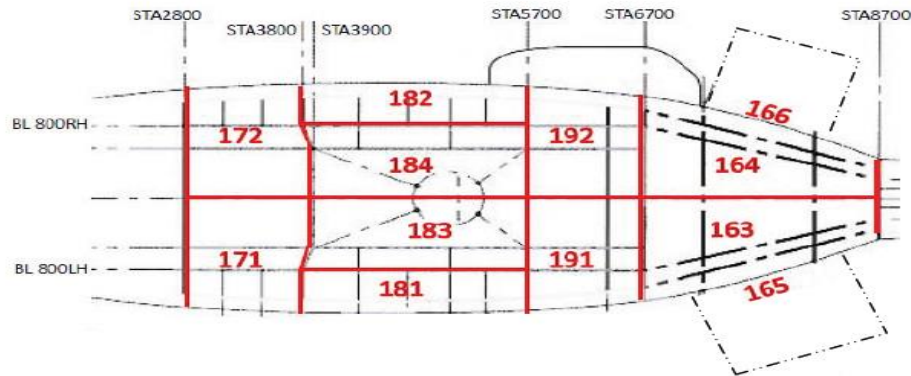

- 163:** LH Rear Upper Fuselage
- 164:** RH Rear Upper Fuselage
- 165:** LH Rear Fuselage Door
- 166:** RH Rear Fuselage Door
- 171:** LH Forward Upper Fuselage
- 172:** RH Forward Upper Fuselage
- 181:** LH Main Upper Fuselage Side
- 182:** RH Main Upper Fuselage Side
- 183:** LH Main Upper Fuselage
- 184:** RH Main Upper Fuselage
- 191:** LH Aft Upper Fuselage
- 192:** RH Aft Upper Fuselage

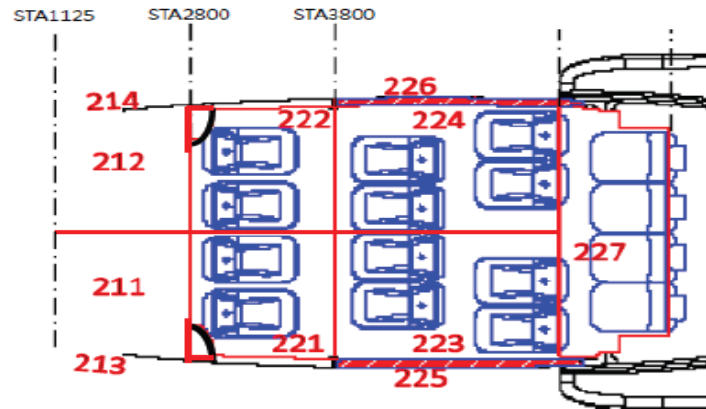

- 211:** Co-Pilot Position
- 212:** Pilot Position
- 213:** LH Cockpit Door
- 214:** RH Cockpit Door
- 221:** LH Forward Cabin
- 222:** RH Forward Cabin
- 223:** LH Main Cabin
- 224:** RH Main Cabin
- 225:** LH Cabin Door
- 226:** RH Cabin Door
- 227:** Rear Cabin

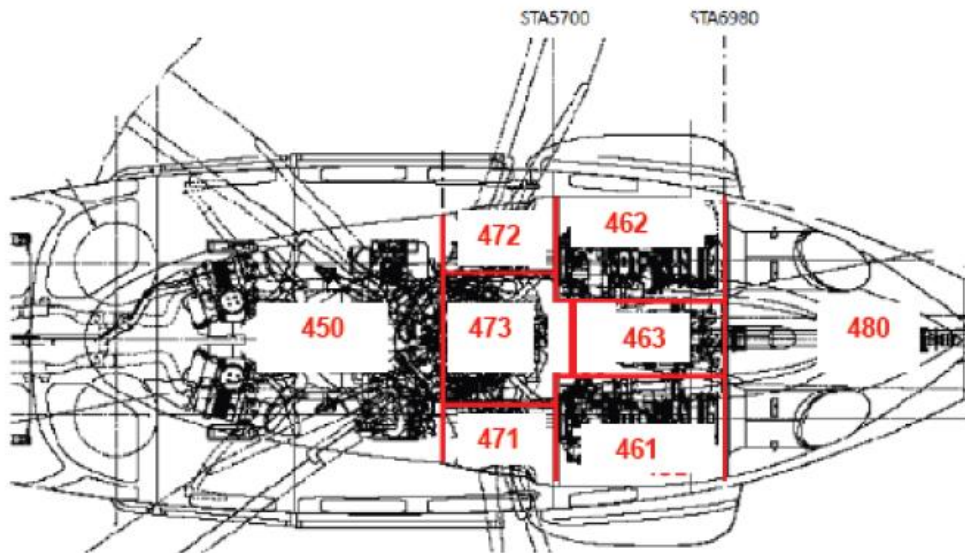

- 450: Forward Fairing Compartment
- 461: LH Engine Compartment
- 462: RH Engine Compartment
- 463: APU Compartment
- 471: LH Air Intake
- 472: RH Air Intake
- 473: Between Air Intakes
- 480: Exhaust Fairing Compartment

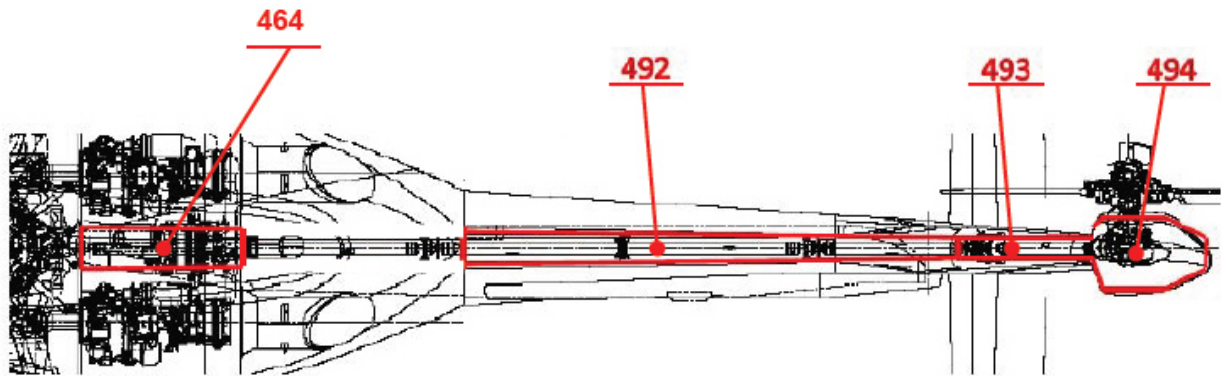

- 464:** Below APU Compartment
- 492:** Tail Drive Shaft Compartment
- 493:** IGB and Pylon Drive Shaft Compartment
- 494:** TGB Compartment



2. AW189ER (using “UB” suffix when different to AW189)

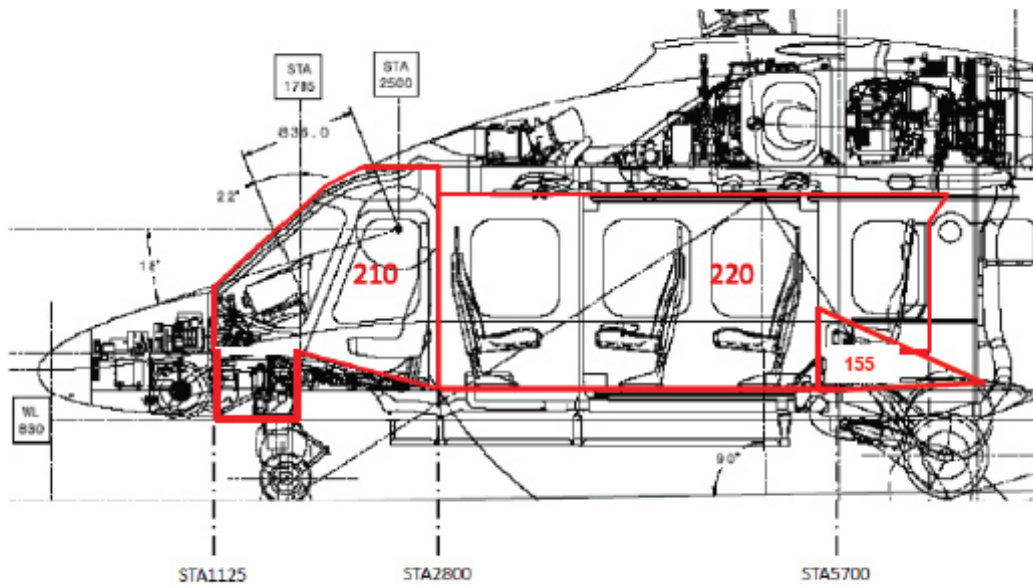

- 155: LH MLG Compartment
- 156: RH MLG Compartment
- 210: Cockpit
- 220: Cabin
- 710: Nose Landing Gear
- 720: RH Main Landing Gear
- 730: LH Main Landing Gear

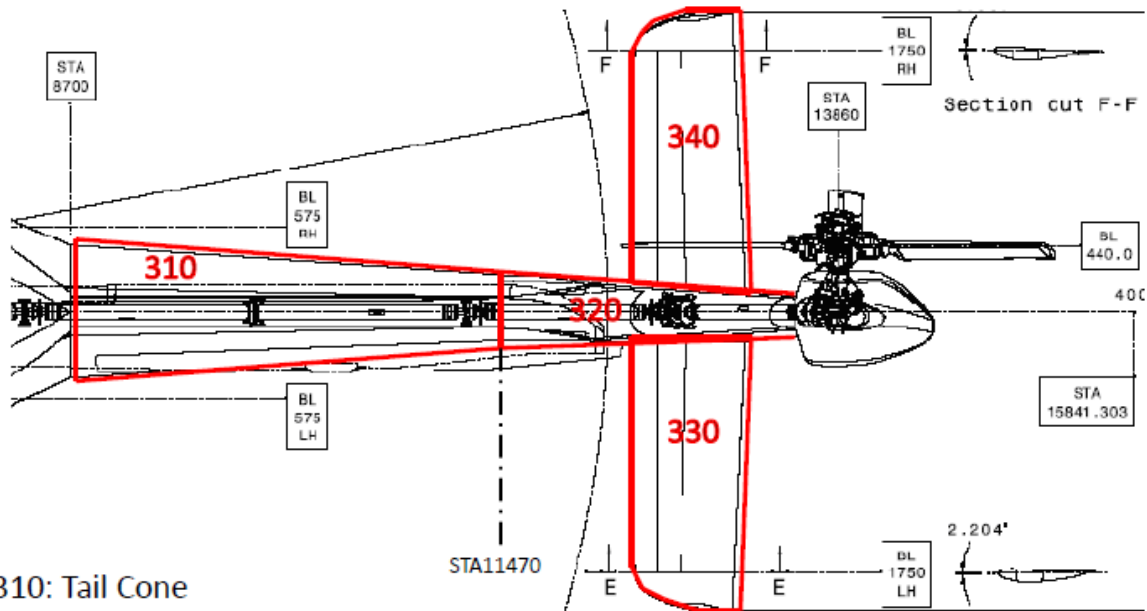

- 310: Tail Cone
- 320: Tail Pylon
- 330: LH Tailplane
- 340: RH Tailplane

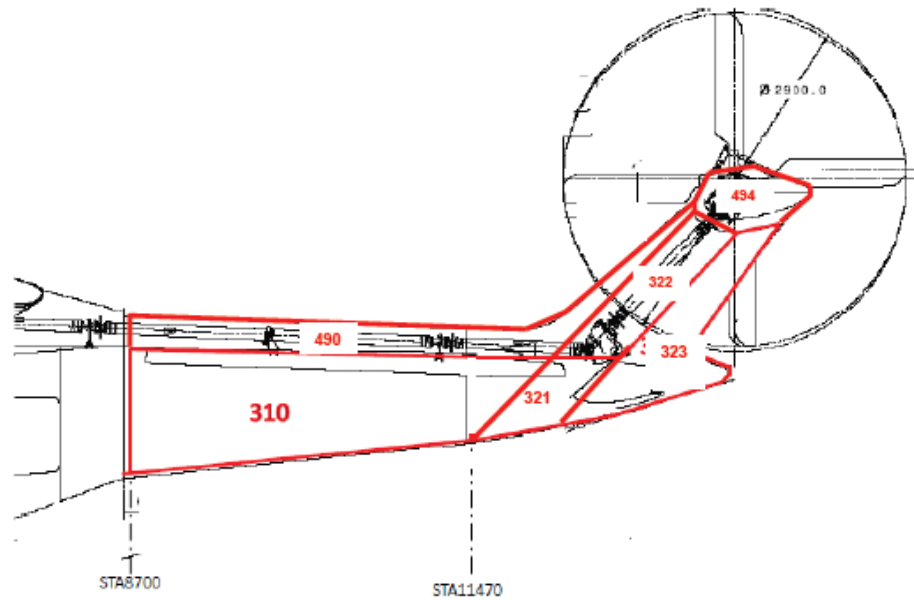

- 310: Tail Cone
- 320: Tail Pylon
- 321: Forward Lower Tail Pylon
- 322: Forward Upper Tail Pylon
- 323: Rear Tail Pylon
- 494: TGB Compartment

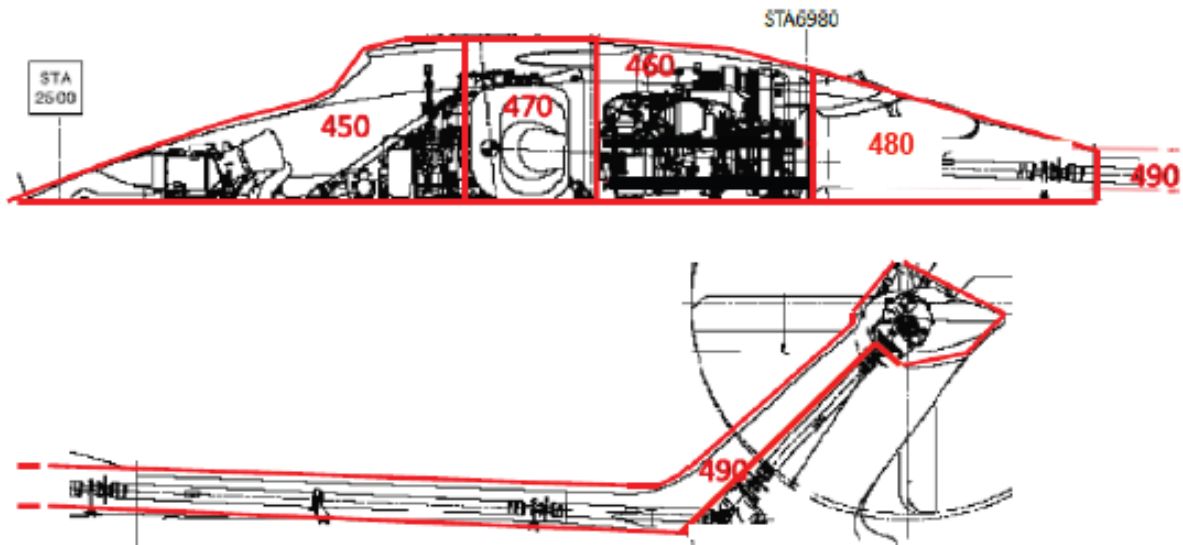

- 450: Forward Fairing Compartment
- 460: Engine Compartments
- 470: Intake Compartments
- 480: Exhaust Fairing Compartment
- 490: Drive Shaft Compartment

- 410: Main Rotor Head (*not showed in this picture*)
- 420: Main Rotor Blades (*not showed in this picture*)
- 430: Tail Rotor Head (*not showed in this picture*)
- 440: Tail Rotor Blades (*not showed in this picture*)

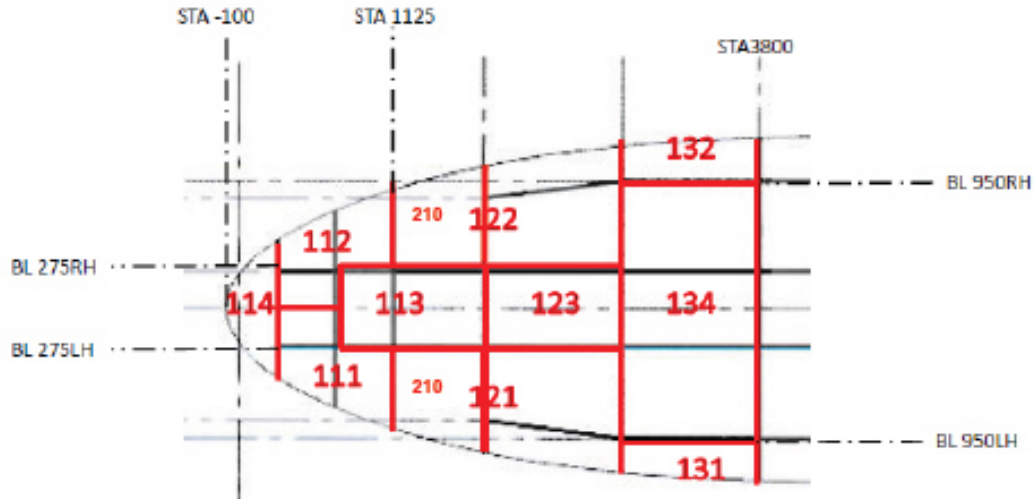

- 111:** LH Lower Nose
- 112:** RH Lower Nose
- 113:** NLG Compartment
- 114:** Nose Fairing Compartment
- 121:** LH Cockpit Lower Fuselage
- 122:** RH Cockpit Lower Fuselage
- 123:** Center Cockpit Lower Fuselage
- 131:** LH Forward Cabin Lower Fuselage
- 132:** RH Forward Cabin Lower Fuselage
- 134:** Center Forward Cabin Lower Fuselage
- 210:** Cockpit

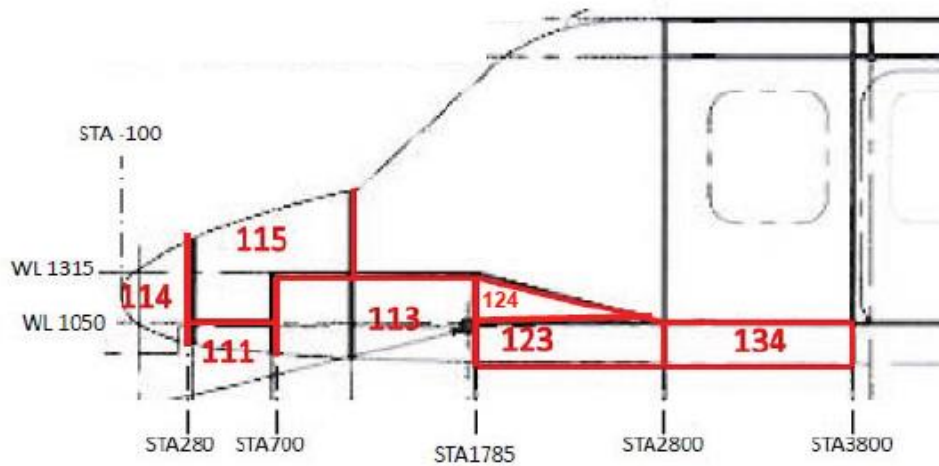

- 111:** LH Lower Nose
- 112:** RH Lower Nose (*not showed in this picture*)
- 113:** NLG Compartment
- 114:** Nose Fairing Compartment
- 115:** LH Nose Avionics Bay
- 116:** RH Nose Avionics Bay (*not showed in this picture*)
- 123:** Center Cockpit Lower Fuselage
- 124:** NLG Retraction Actuator Compartment
- 134:** Center Forward Cabin Lower Fuselage

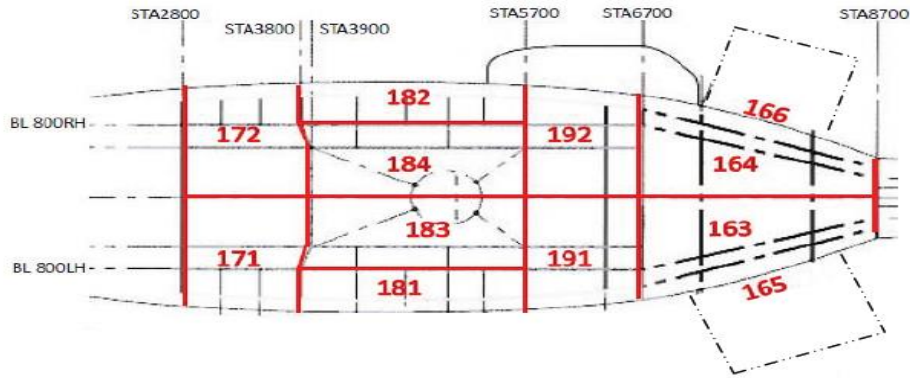

- 163:** LH Rear Upper Fuselage
- 164:** RH Rear Upper Fuselage
- 165:** LH Rear Fuselage Door
- 166:** RH Rear Fuselage Door
- 171:** LH Forward Upper Fuselage
- 172:** RH Forward Upper Fuselage
- 181:** LH Main Upper Fuselage Side
- 182:** RH Main Upper Fuselage Side
- 183:** LH Main Upper Fuselage
- 184:** RH Main Upper Fuselage
- 191:** LH Aft Upper Fuselage
- 192:** RH Aft Upper Fuselage

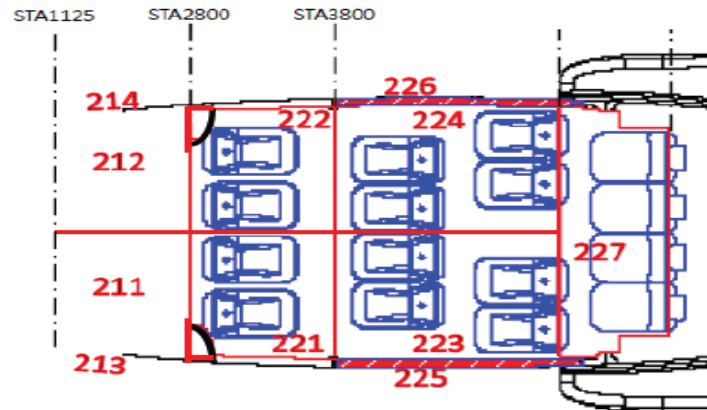

- 211:** Co-Pilot Position
- 212:** Pilot Position
- 213:** LH Cockpit Door
- 214:** RH Cockpit Door
- 221:** LH Forward Cabin
- 222:** RH Forward Cabin
- 223:** LH Main Cabin
- 224:** RH Main Cabin
- 225:** LH Cabin Door
- 226:** RH Cabin Door
- 227:** Rear Cabin

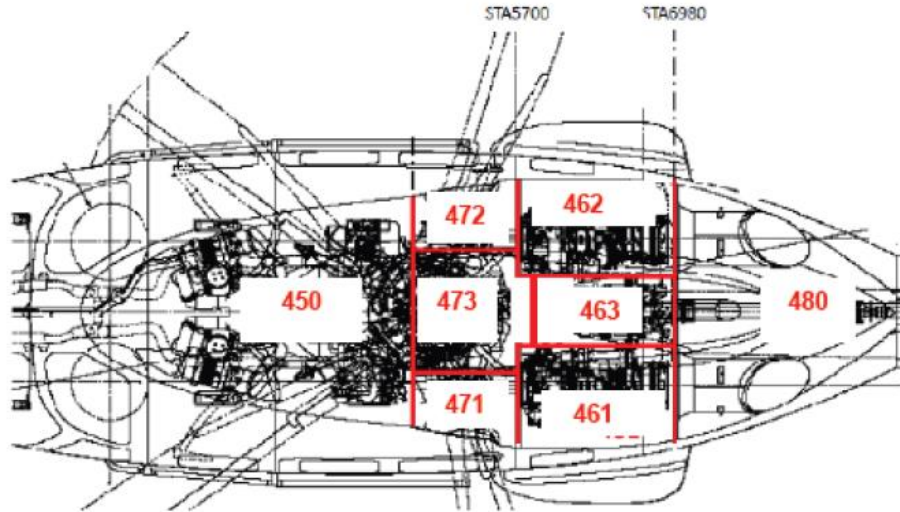

- 450: Forward Fairing Compartment
- 461: LH Engine Compartment
- 462: RH Engine Compartment
- 463: APU Compartment
- 471: LH Air Intake
- 472: RH Air Intake
- 473: Between Air Intakes
- 480: Exhaust Fairing Compartment

Helicopter Upper Deck View From Above

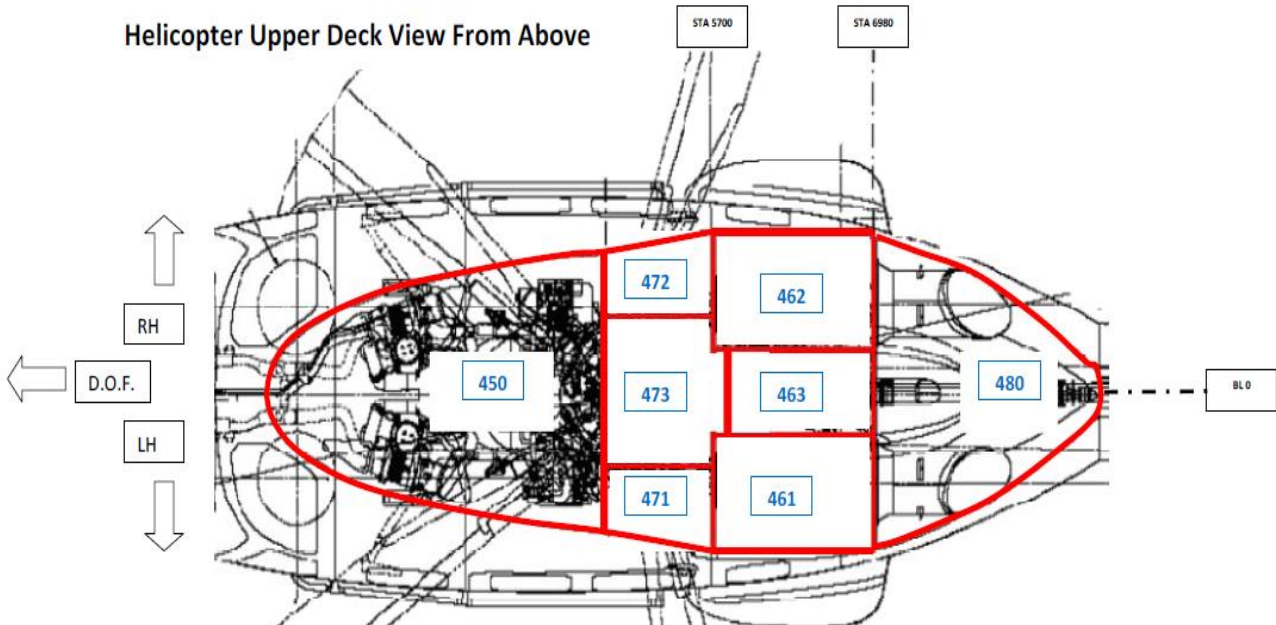

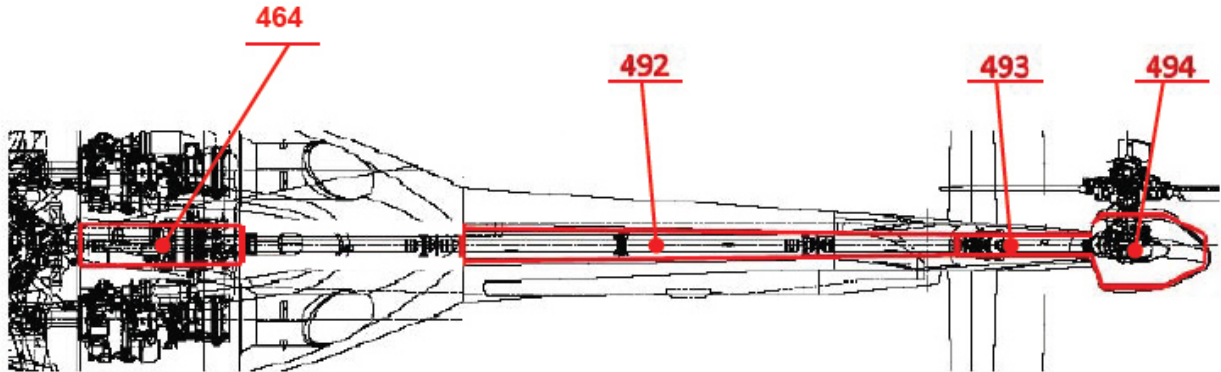

- 464: Below APU Compartment
- 492: Tail Drive Shaft Compartment
- 493: IGB and Pylon Drive Shaft Compartment
- 494: TGB Compartment



- 121UB: LH Cockpit Lower Fuselage Underbelly
- 122UB: RH Cockpit Lower Fuselage Underbelly
- 123UB: Center Cockpit Lower Fuselage Underbelly
- 127UB: LH Cockpit Under-Belly Fuselage
- 128UB: RH Cockpit Under-Belly Fuselage
- 134UB: Centre Forward Cabin Lower Underbelly
- 138UB: Centre Cabin Fuselage RH Fuel Tank Compartment - Underbelly
- 139UB: Centre Cabin Fuselage LH Fuel Tank Compartment - Underbelly
- 143UB: Centre Cabin Lower Fuselage - Underbelly
- 147UB: Centre Cabin Fuselage LH Fuel Hoses Compartment Underbelly
- 148UB: Centre Cabin Fuselage RH Fuel Hoses Compartment Underbelly
- 157UB: LH Lower Cowling Compartment Underbelly
- 158UB: RH Lower Cowling Compartment Underbelly
- 159UB: Center Lower Cowling Compartment Underbelly

Helicopter Belly General View from Above

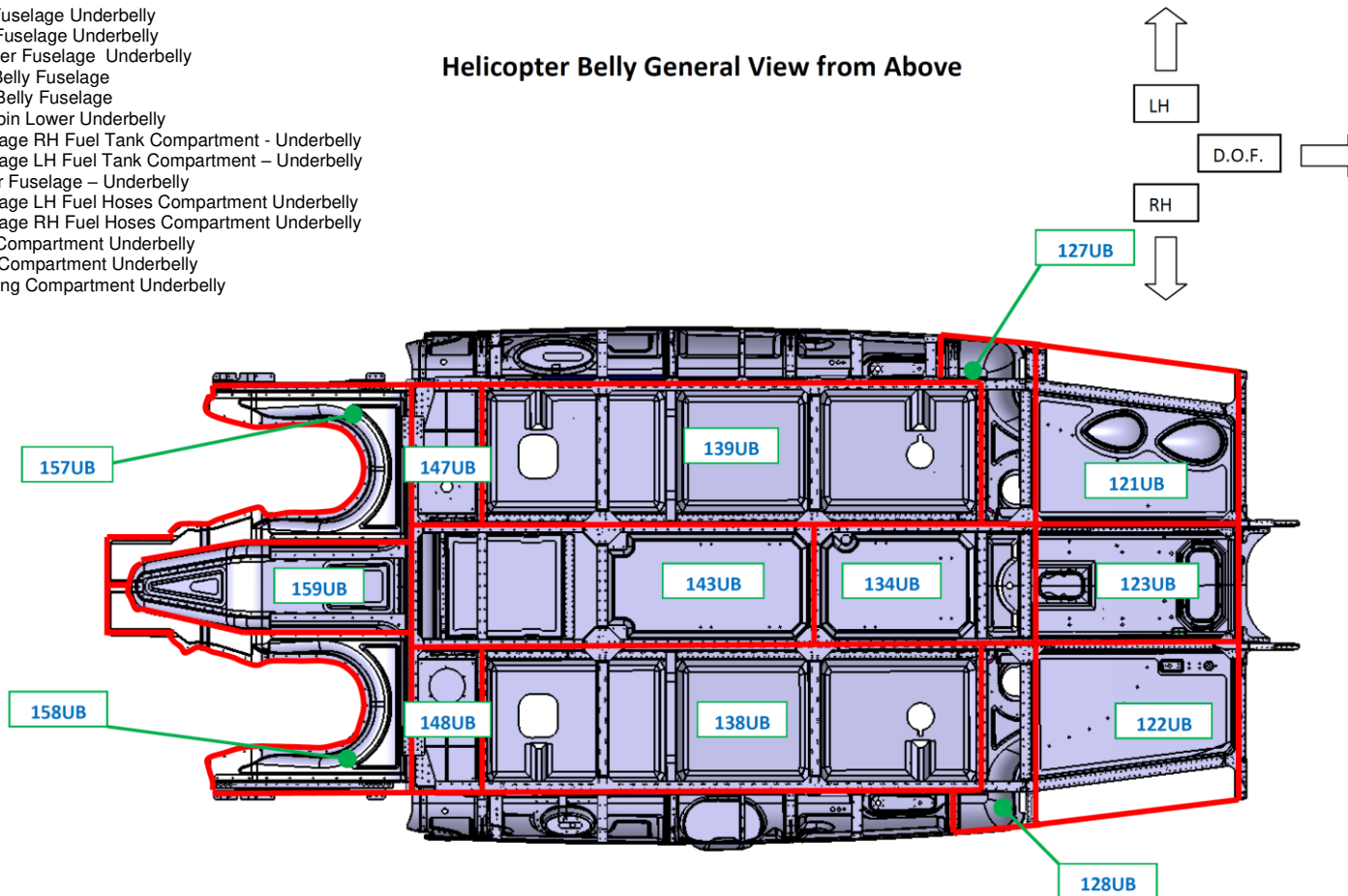

This document contains information that is confidential and proprietary to Leonardo S.p.a. ('the Company') and is supplied on the express condition that it may not be disclosed to any third party, or reproduced in whole or in part, or used for manufacture, or used for any purpose other than for which it is supplied, without the prior written consent of the Company. Every permitted disclosure, reproduction, adaptation or publication of this document in whole or in part and in any manner or form shall prominently contain this notice



- 121UB: LH Cockpit Lower Fuselage Underbelly
- 122UB: RH Cockpit Lower Fuselage Underbelly
- 123UB: Center Cockpit Lower Fuselage Underbelly
- 127UB: LH Cockpit Under-Belly Fuselage
- 128UB: RH Cockpit Under-Belly Fuselage
- 134UB: Centre Forward Cabin Lower Underbelly
- 138UB: Centre Cabin Fuselage RH Fuel Tank Compartment - Underbelly
- 139UB: Centre Cabin Fuselage LH Fuel Tank Compartment - Underbelly
- 143UB: Centre Cabin Lower Fuselage - Underbelly
- 147UB: Centre Cabin Fuselage LH Fuel Hoses Compartment Underbelly
- 148UB: Centre Cabin Fuselage RH Fuel Hoses Compartment Underbelly
- 157UB: LH Lower Cowling Compartment Underbelly
- 158UB: RH Lower Cowling Compartment Underbelly
- 159UB: Center Lower Cowling Compartment Underbelly

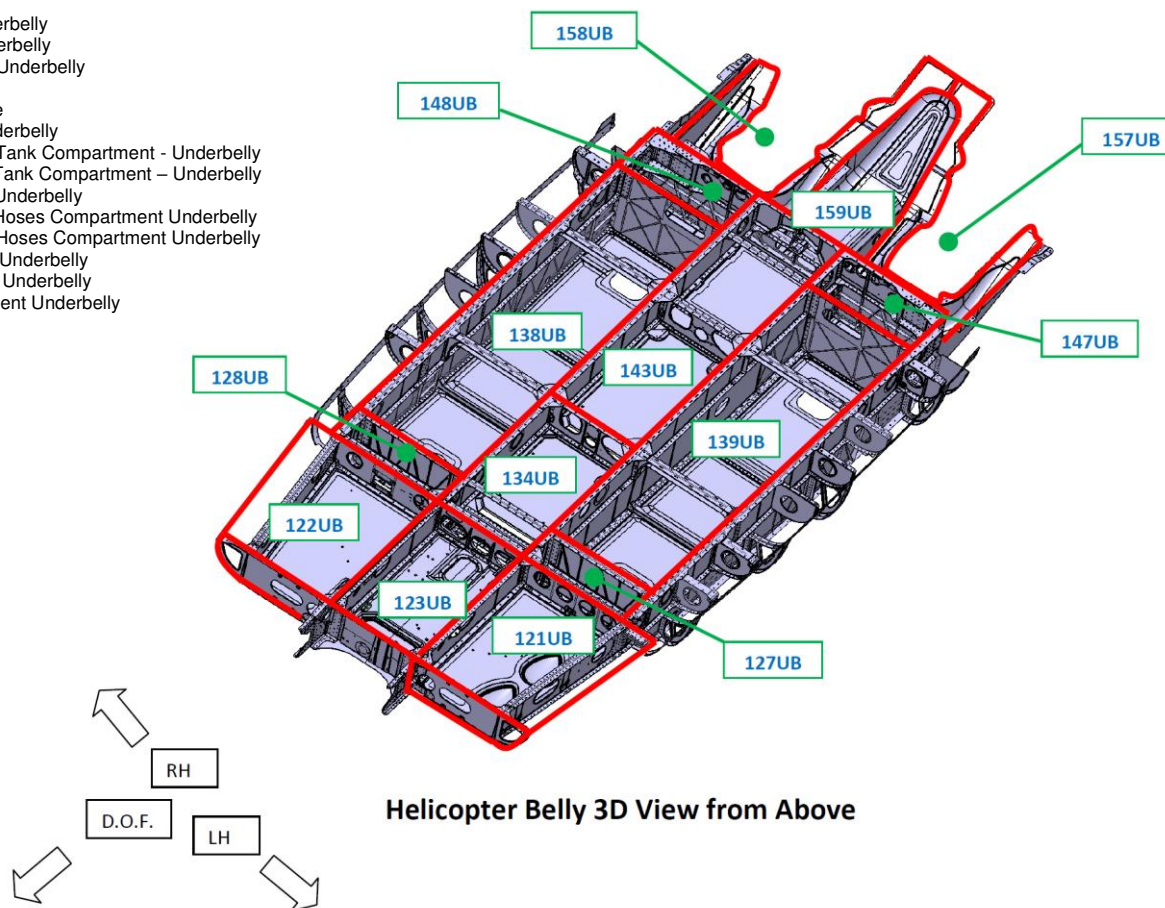

Helicopter Belly 3D View from Above

© Copyright 2024 Leonardo S.p.a.

This document contains information that is confidential and proprietary to Leonardo S.p.a. ('the Company') and is supplied on the express condition that it may not be disclosed to any third party, or reproduced in whole or in part, or used for manufacture, or used for any purpose other than for which it is supplied, without the prior written consent of the Company. Every permitted disclosure, reproduction, adaptation or publication of this document in whole or in part and in any manner or form shall prominently contain this notice



- 125UB: Centre Cockpit Under-Belly Fuselage
- 127UB: LH Cockpit Under-Belly Fuselage
- 128UB: RH Cockpit Under-Belly Fuselage
- 135UB: Centre Cabin Fuselage Fuel Tank Compartment Underbelly
- 136UB: RH Forward Cabin Under-Belly Fuselage Side
- 137UB: LH Forward Cabin Under-Belly Fuselage Side
- 138UB: Centre Cabin Fuselage RH Fuel Tank Compartment - Underbelly
- 139UB: Centre Cabin Fuselage LH Fuel Tank Compartment Underbelly
- 145UB: LH Cabin Centre Under-Belly Fuselage Side
- 146UB: RH Cabin Centre Under-Belly Fuselage Side
- 147UB: Centre Cabin Fuselage LH Fuel Hoses Compartment Underbelly
- 148UB: Centre Cabin Fuselage RH Fuel Hoses Compartment Underbelly
- 149UB: Centre Cabin Fuselage Cargo Hook Compartment Underbelly
- 157UB: LH Lower Cowling Compartment Underbelly
- 158UB: RH Lower Cowling Compartment Underbelly
- 159UB: Center Lower Cowling Compartment Underbelly

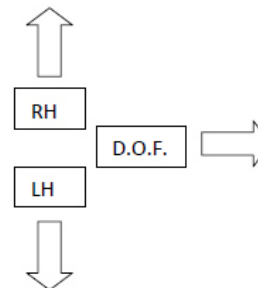

Helicopter Belly General View from Below

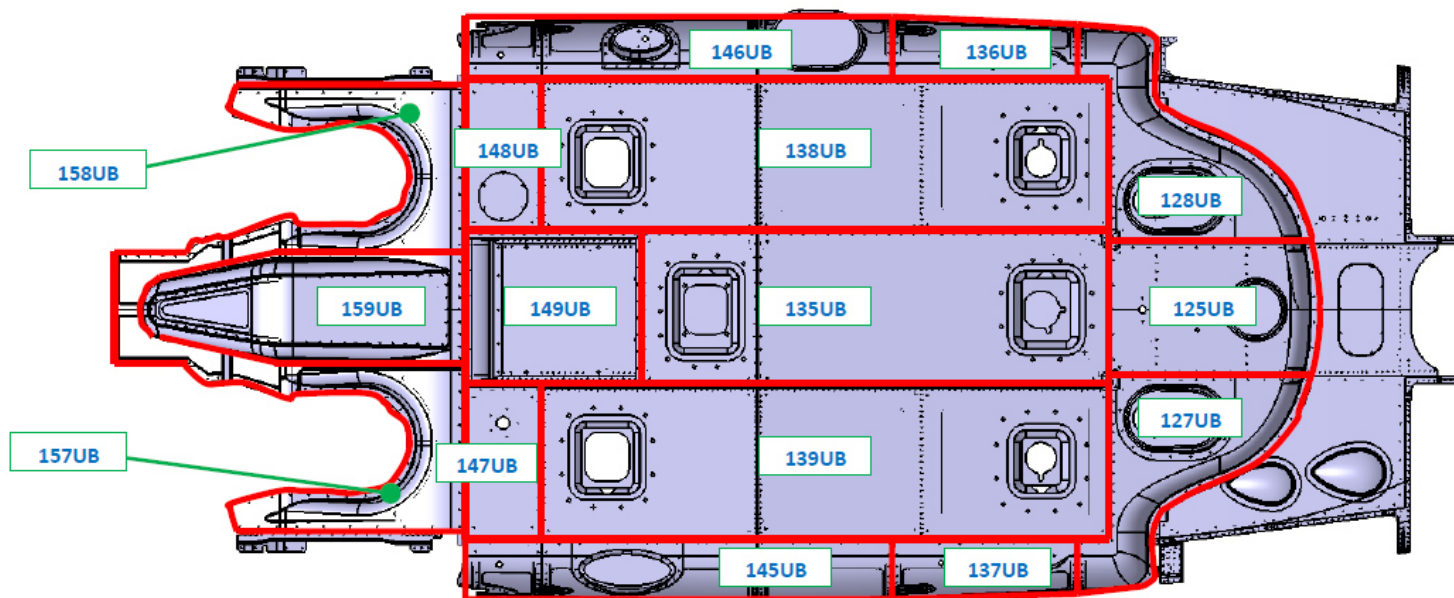

© Copyright 2024 Leonardo S.p.a.

This document contains information that is confidential and proprietary to Leonardo S.p.a. ('the Company') and is supplied on the express condition that it may not be disclosed to any third party, or reproduced in whole or in part, or used for manufacture, or used for any purpose other than for which it is supplied, without the prior written consent of the Company. Every permitted disclosure, reproduction, adaptation or publication of this document in whole or in part and in any manner or form shall prominently contain this notice



- 135UB: Centre Cabin Fuselage Fuel Tank Compartment Underbelly
- 138UB: Centre Cabin Fuselage RH Fuel Tank Compartment - Underbelly
- 139UB: Centre Cabin Fuselage LH Fuel Tank Compartment Underbelly
- 147UB: Centre Cabin Fuselage LH Fuel Hoses Compartment Underbelly
- 148UB: Centre Cabin Fuselage RH Fuel Hoses Compartment Underbelly
- 149UB: Centre Cabin Fuselage Cargo Hook Compartment Underbelly

Helicopter Belly 3D View from Below

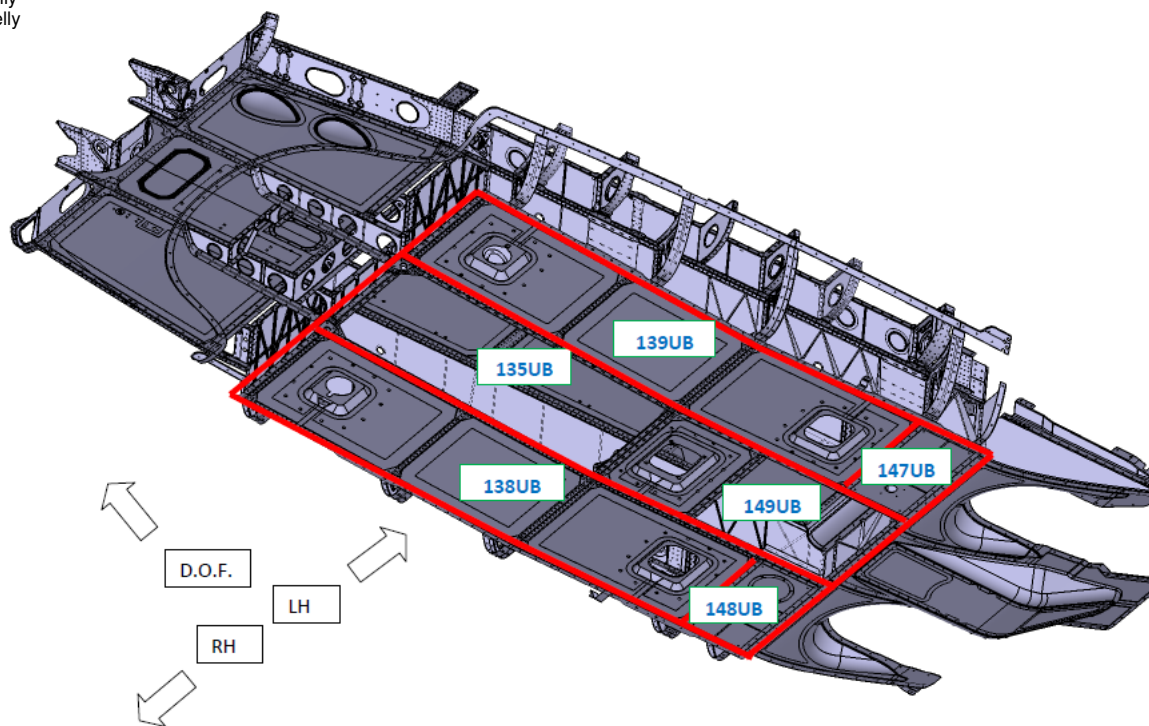

© Copyright 2024 Leonardo S.p.a.

This document contains information that is confidential and proprietary to Leonardo S.p.a. ('the Company') and is supplied on the express condition that it may not be disclosed to any third party, or reproduced in whole or in part, or used for manufacture, or used for any purpose other than for which it is supplied, without the prior written consent of the Company. Every permitted disclosure, reproduction, adaptation or publication of this document in whole or in part and in any manner or form shall prominently contain this notice



125UB: Centre Cockpit Under-Belly Fuselage
127UB: LH Cockpit Under-Belly Fuselage
128UB: RH Cockpit Under-Belly Fuselage

Helicopter Nose Under- Belly Detail

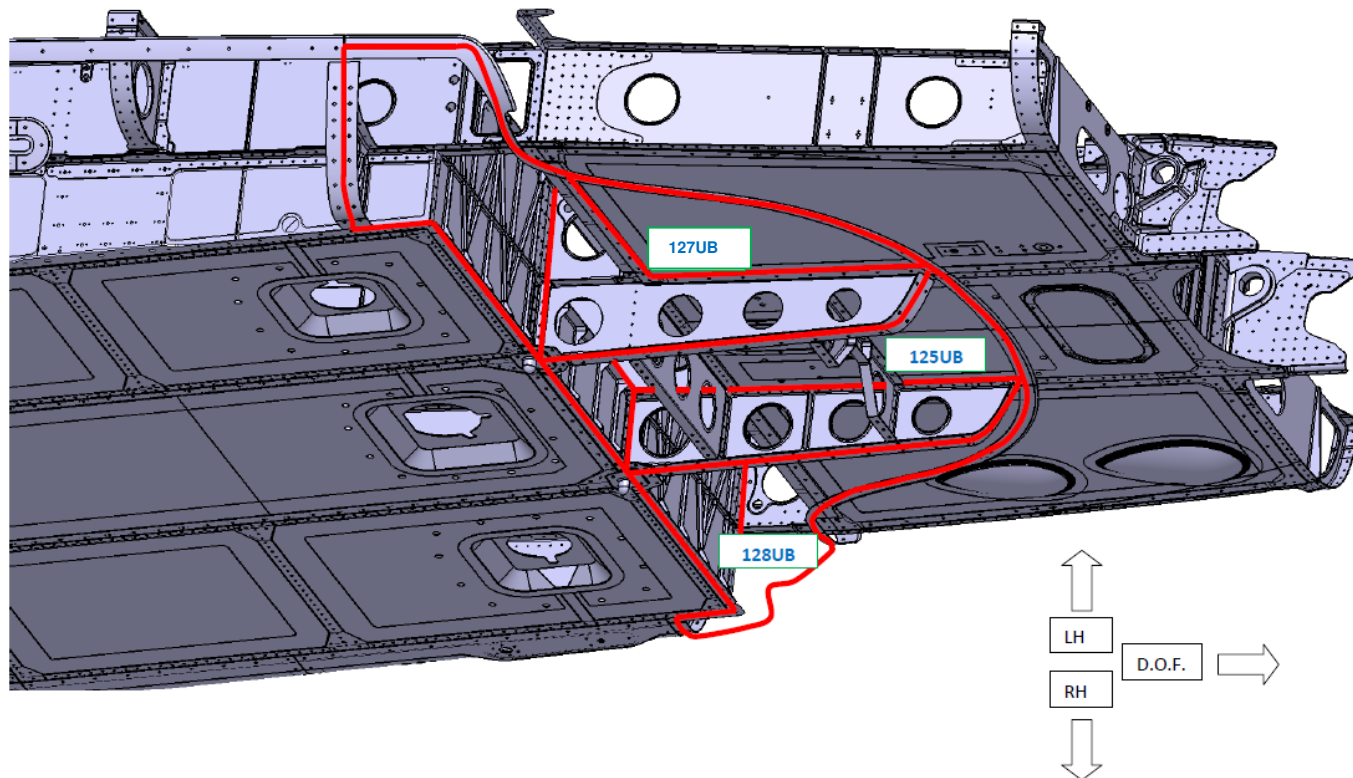

© Copyright 2024 Leonardo S.p.a.

This document contains information that is confidential and proprietary to Leonardo S.p.a. ('the Company') and is supplied on the express condition that it may not be disclosed to any third party, or reproduced in whole or in part, or used for manufacture, or used for any purpose other than for which it is supplied, without the prior written consent of the Company. Every permitted disclosure, reproduction, adaptation or publication of this document in whole or in part and in any manner or form shall prominently contain this notice



- 121UB: LH Cockpit Lower Fuselage Underbelly
- 122UB: RH Cockpit Lower Fuselage Underbelly
- 131UB: LH Forward Cabin Lower Fuselage Side Underbelly
- 132UB: RH Forward Cabin Lower Fuselage Side Underbelly
- 141UB: LH Cabin Centre Lower Fuselage Side Underbelly
- 142UB:RH Cabin Centre Lower Fuselage Side Underbelly

Helicopter Nose Belly Lateral View from Right

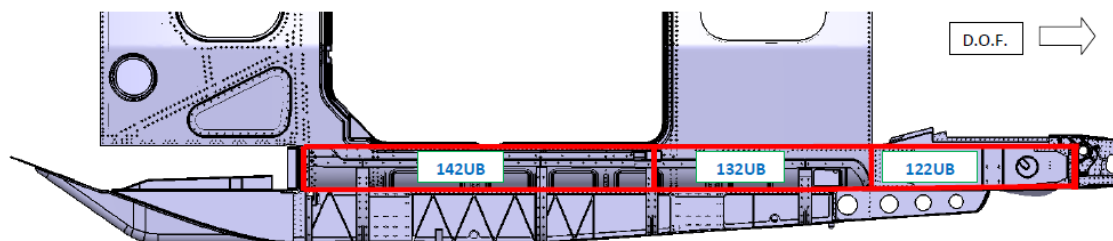

Helicopter Nose Belly Lateral View from Left

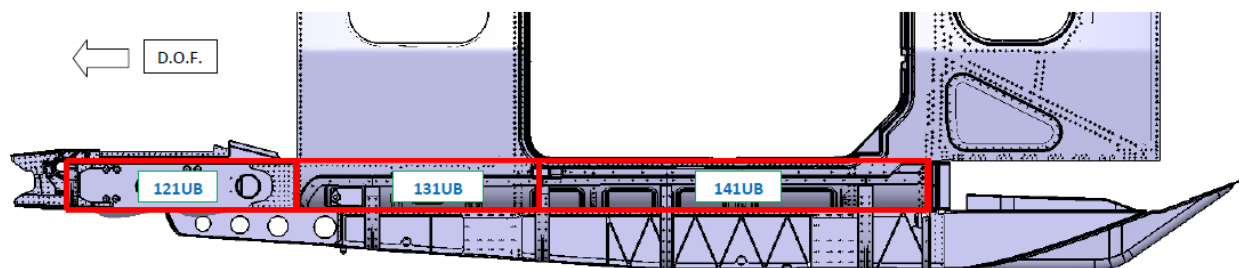

© Copyright 2024 Leonardo S.p.a.

This document contains information that is confidential and proprietary to Leonardo S.p.a. ('the Company') and is supplied on the express condition that it may not be disclosed to any third party, or reproduced in whole or in part, or used for manufacture, or used for any purpose other than for which it is supplied, without the prior written consent of the Company. Every permitted disclosure, reproduction, adaptation or publication of this document in whole or in part and in any manner or form shall prominently contain this notice



- 147UB: Centre Cabin Fuselage LH Fuel Hoses Compartment Underbelly
- 148UB: Centre Cabin Fuselage RH Fuel Hoses Compartment Underbelly
- 157UB: LH Lower Cowling Compartment Underbelly
- 158UB: RH Lower Cowling Compartment Underbelly
- 159UB: Center Lower Cowling Compartment Underbelly

Helicopter Lower Fuel Compartment –Detail -

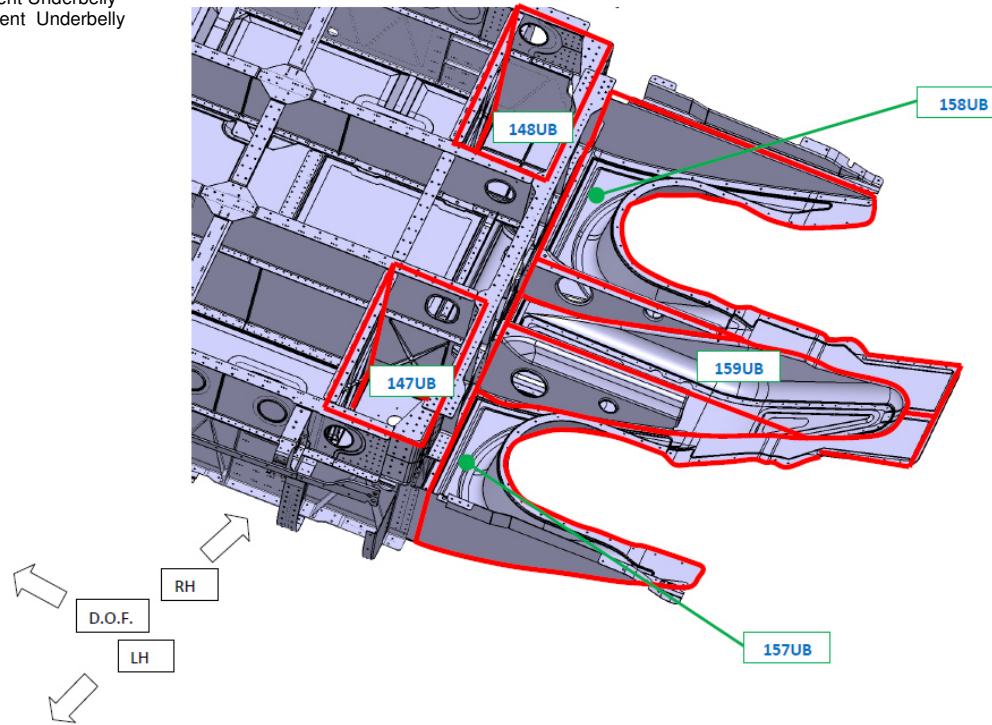

© Copyright 2024 Leonardo S.p.a.

This document contains information that is confidential and proprietary to Leonardo S.p.a. ('the Company') and is supplied on the express condition that it may not be disclosed to any third party, or reproduced in whole or in part, or used for manufacture, or used for any purpose other than for which it is supplied, without the prior written consent of the Company. Every permitted disclosure, reproduction, adaptation or publication of this document in whole or in part and in any manner or form shall prominently contain this notice



3. AW189 and AW189ER Access Panels Numbering

© Copyright 2024 Leonardo S.p.a.

This document contains information that is confidential and proprietary to Leonardo S.p.a. ('the Company') and is supplied on the express condition that it may not be disclosed to any third party, or reproduced in whole or in part, or used for manufacture, or used for any purpose other than for which it is supplied, without the prior written consent of the Company. Every permitted disclosure, reproduction, adaptation or publication of this document in whole or in part and in any manner or form shall prominently contain this notice

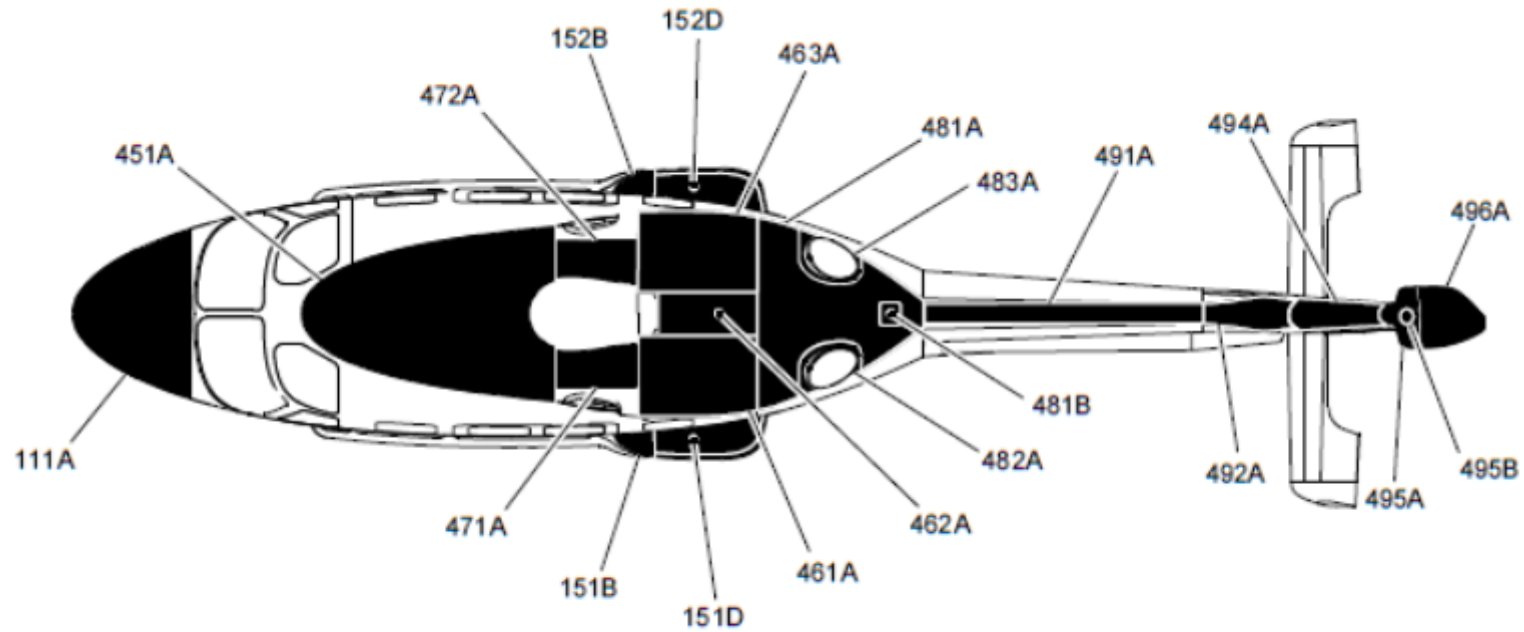

© Copyright 2024 Leonardo S.p.a.

This document contains information that is confidential and proprietary to Leonardo S.p.a. ('the Company') and is supplied on the express condition that it may not be disclosed to any third party, or reproduced in whole or in part, or used for manufacture, or used for any purpose other than for which it is supplied, without the prior written consent of the Company. Every permitted disclosure, reproduction, adaptation or publication of this document in whole or in part and in any manner or form shall prominently contain this notice

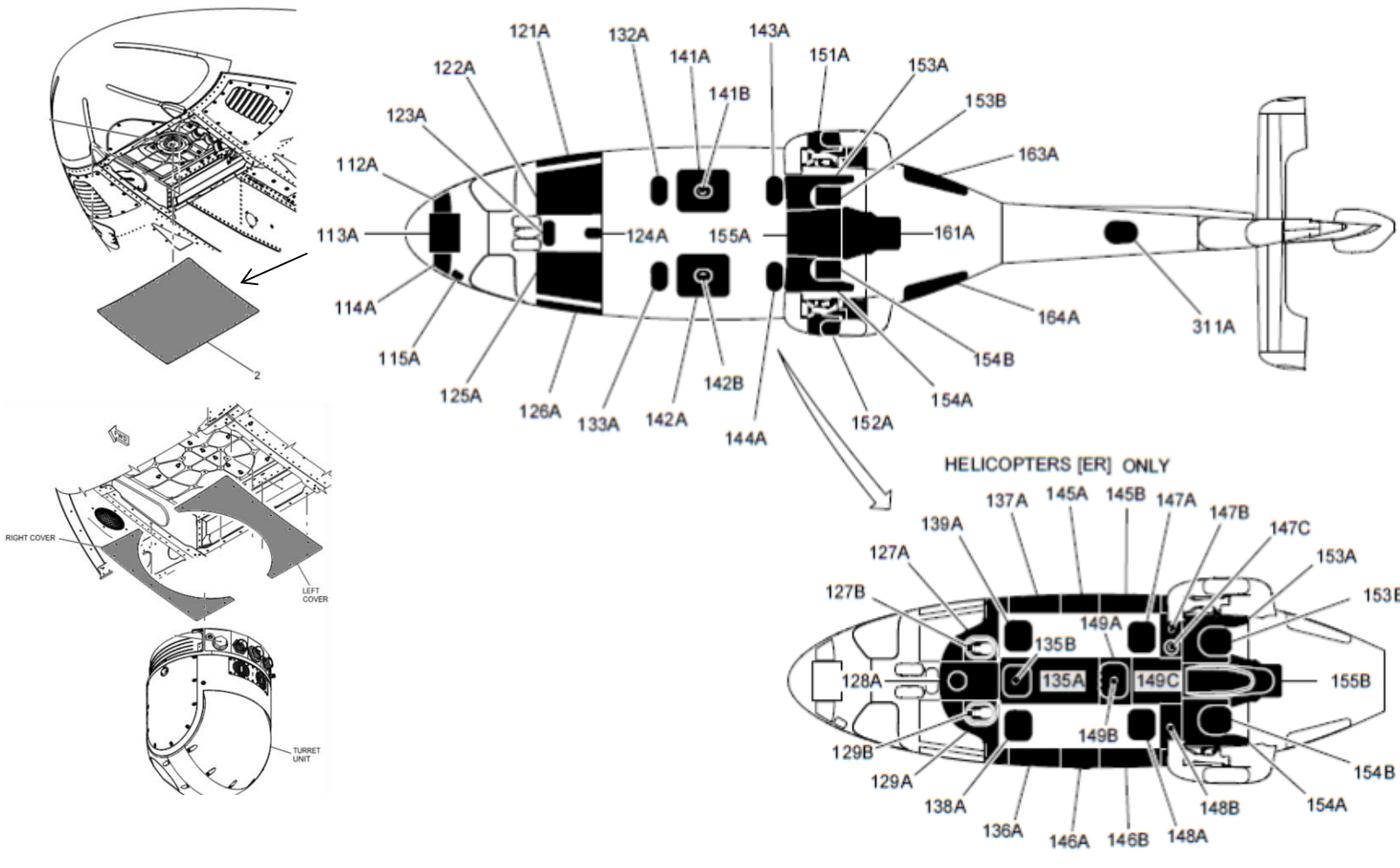

© Copyright 2024 Leonardo S.p.a.

This document contains information that is confidential and proprietary to Leonardo S.p.a. ('the Company') and is supplied on the express condition that it may not be disclosed to any third party, or reproduced in whole or in part, or used for manufacture, or used for any purpose other than for which it is supplied, without the prior written consent of the Company. Every permitted disclosure, reproduction, adaptation or publication of this document in whole or in part and in any manner or form shall prominently contain this notice

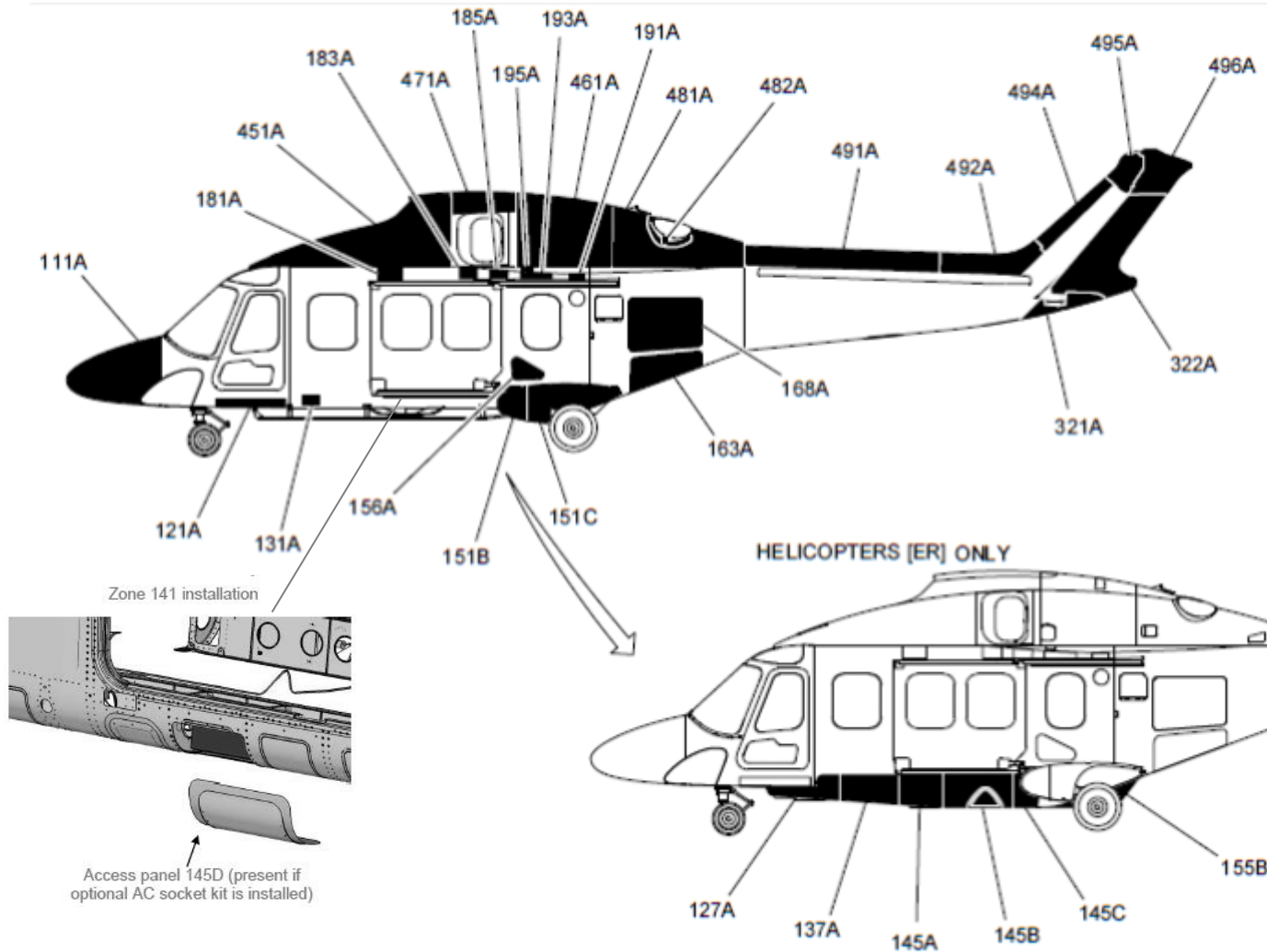

© Copyright 2024 Leonardo S.p.a.

This document contains information that is confidential and proprietary to Leonardo S.p.a. ('the Company') and is supplied on the express condition that it may not be disclosed to any third party, or reproduced in whole or in part, or used for manufacture, or used for any purpose other than for which it is supplied, without the prior written consent of the Company. Every permitted disclosure, reproduction, adaptation or publication of this document in whole or in part and in any manner or form shall prominently contain this notice



AW189 Maintenance Review Board Report

189G0000M006

Issue V

Page App 2-38

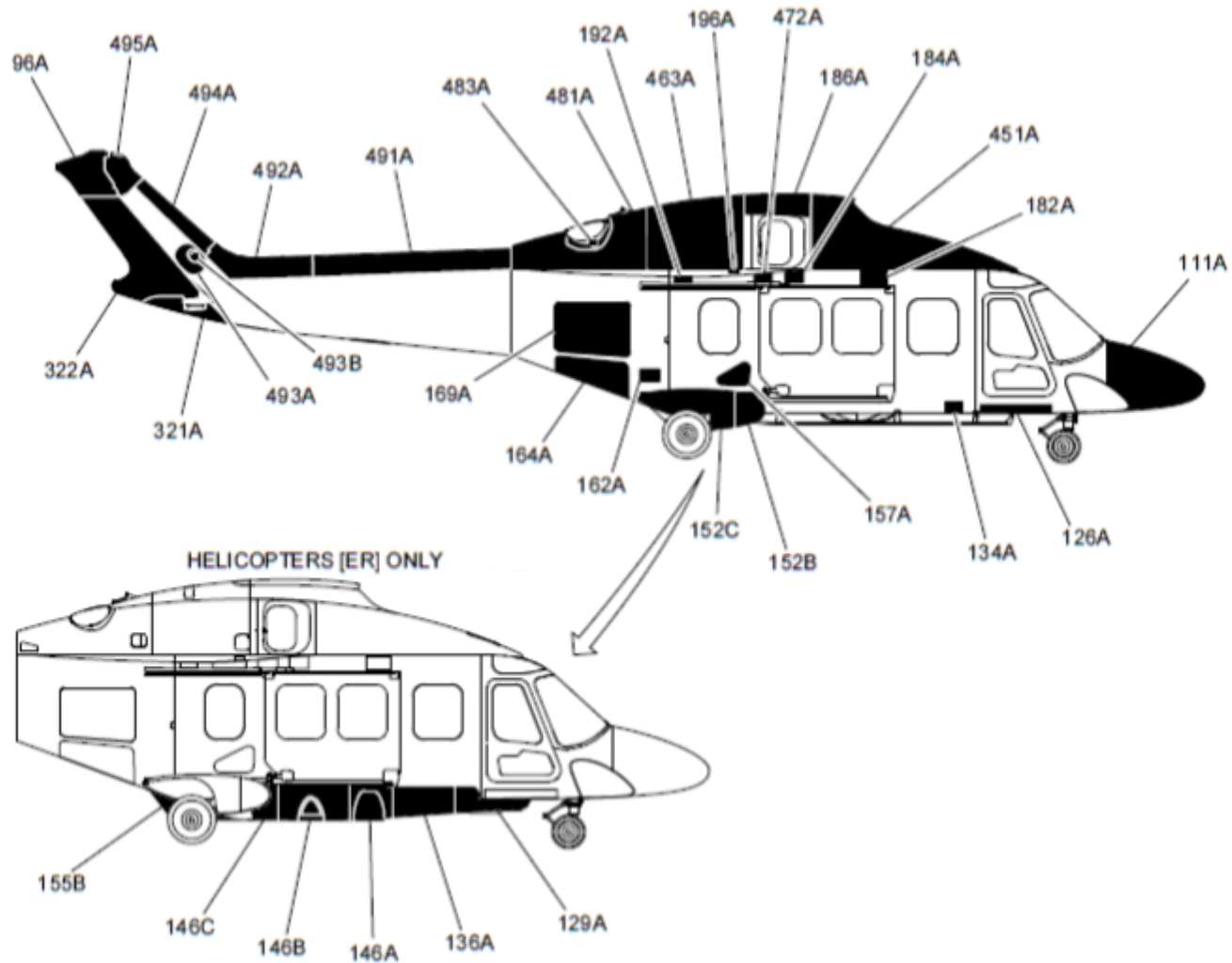

© Copyright 2024 Leonardo S.p.a.

This document contains information that is confidential and proprietary to Leonardo S.p.a. ("the Company") and is supplied on the express condition that it may not be disclosed to any third party, or reproduced in whole or in part, or used for manufacture, or used for any purpose other than for which it is supplied, without the prior written consent of the Company. Every permitted disclosure, reproduction, adaptation or publication of this document in whole or in part and in any manner or form shall prominently contain this notice

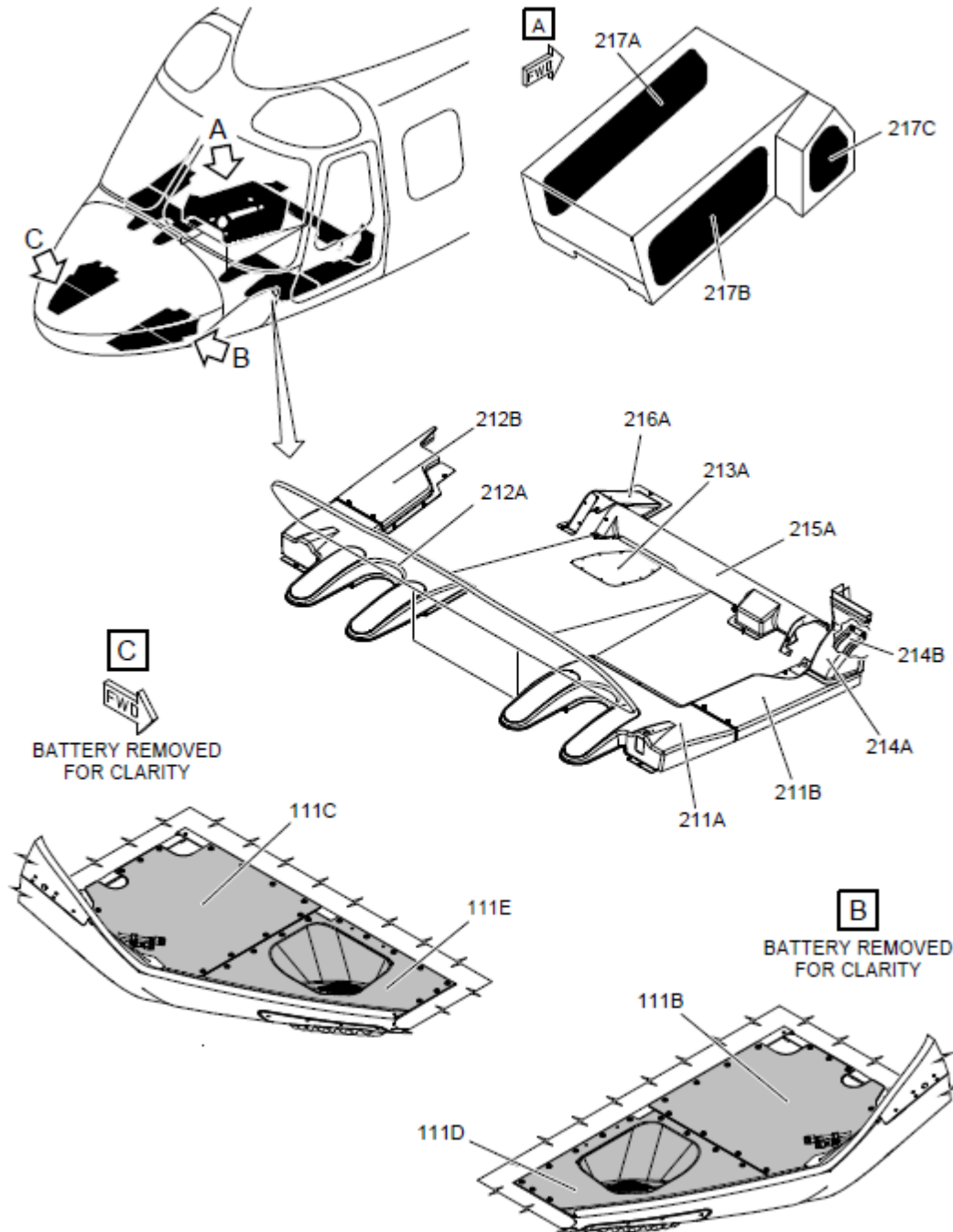

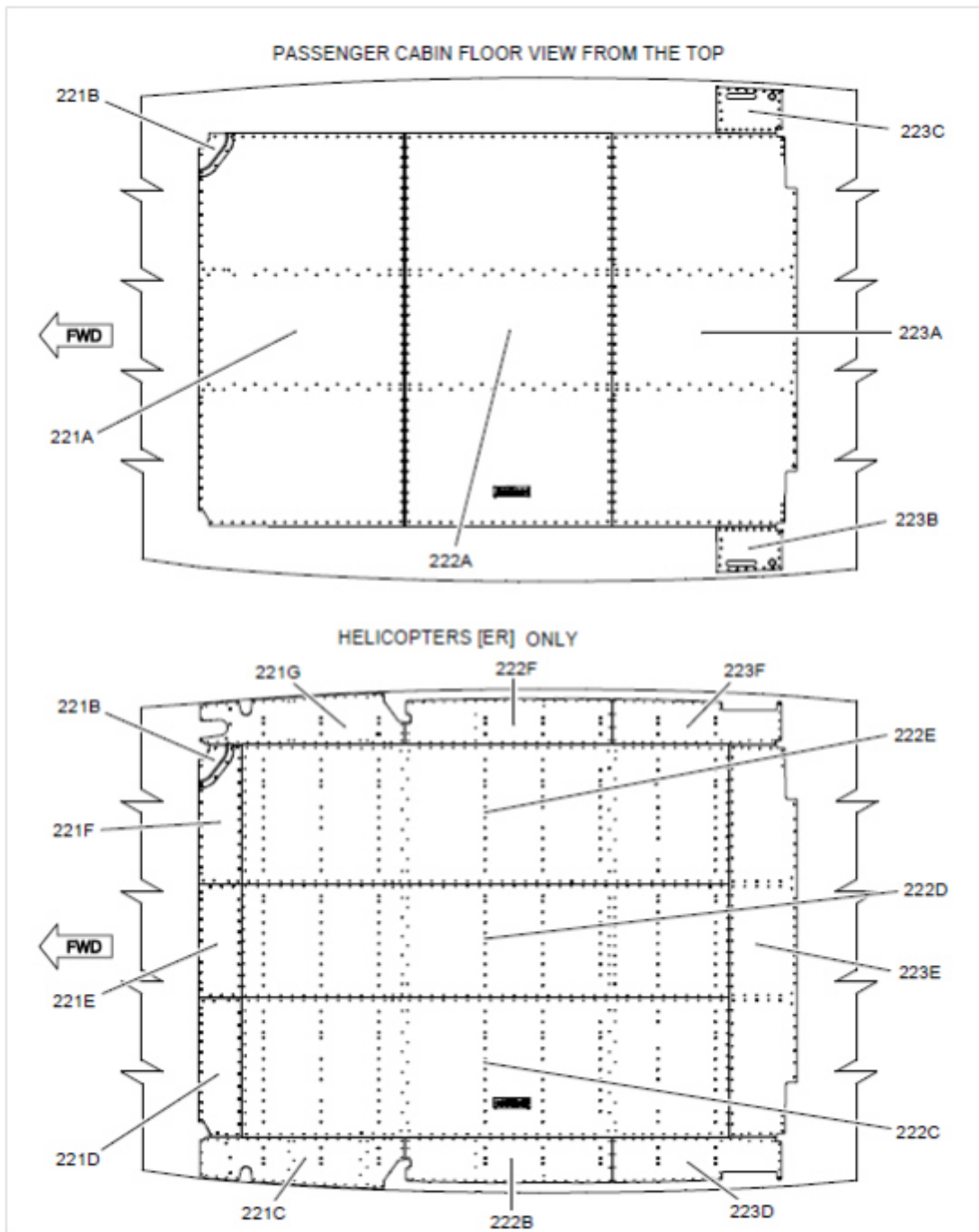

© Copyright 2024 Leonardo S.p.a.

This document contains information that is confidential and proprietary to Leonardo S.p.a. ('the Company') and is supplied on the express condition that it may not be disclosed to any third party, or reproduced in whole or in part, or used for manufacture, or used for any purpose other than for which it is supplied, without the prior written consent of the Company. Every permitted disclosure, reproduction, adaptation or publication of this document in whole or in part and in any manner or form shall prominently contain this notice

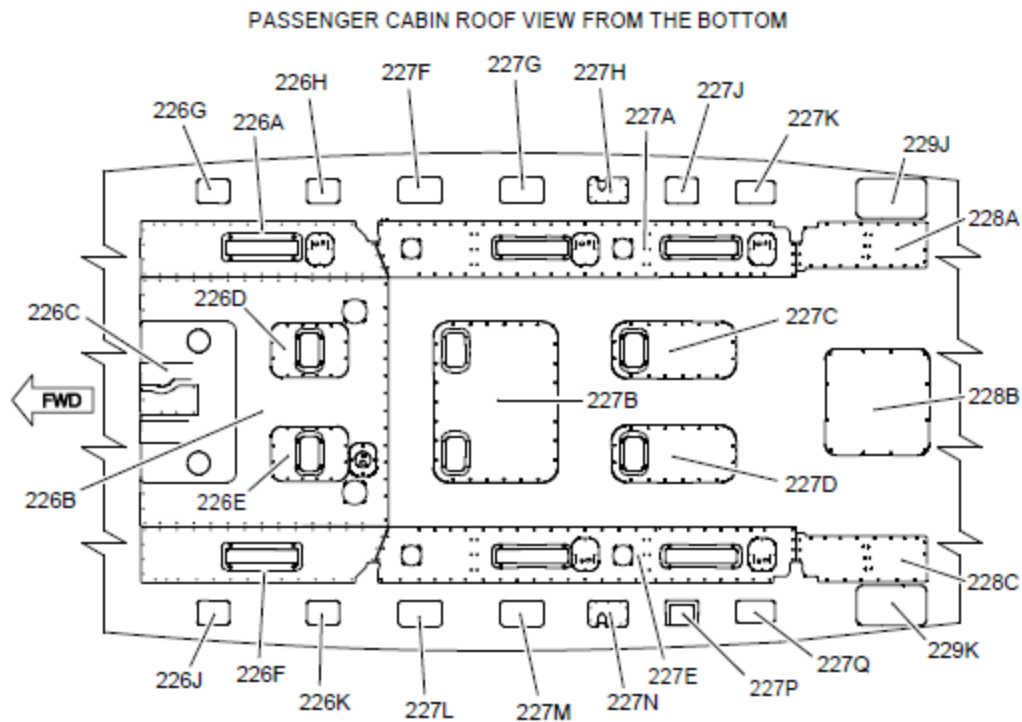

© Copyright 2024 Leonardo S.p.a.

This document contains information that is confidential and proprietary to Leonardo S.p.a. ('the Company') and is supplied on the express condition that it may not be disclosed to any third party, or reproduced in whole or in part, or used for manufacture, or used for any purpose other than for which it is supplied, without the prior written consent of the Company. Every permitted disclosure, reproduction, adaptation or publication of this document in whole or in part and in any manner or form shall prominently contain this notice

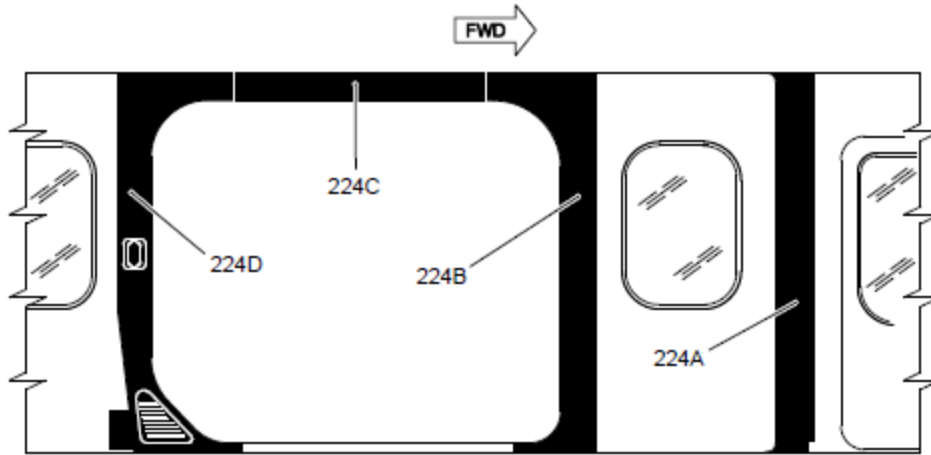

PASSENGER CABIN LEFT DOOR VIEW FROM INBOARD

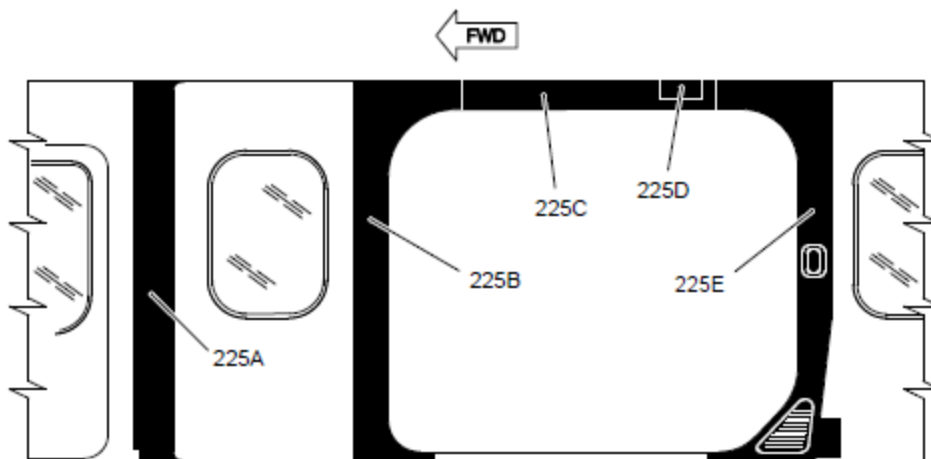

PASSENGER CABIN RIGHT DOOR VIEW FROM INBOARD

© Copyright 2024 Leonardo S.p.a.

This document contains information that is confidential and proprietary to Leonardo S.p.a. ('the Company') and is supplied on the express condition that it may not be disclosed to any third party, or reproduced in whole or in part, or used for manufacture, or used for any purpose other than for which it is supplied, without the prior written consent of the Company. Every permitted disclosure, reproduction, adaptation or publication of this document in whole or in part and in any manner or form shall prominently contain this notice

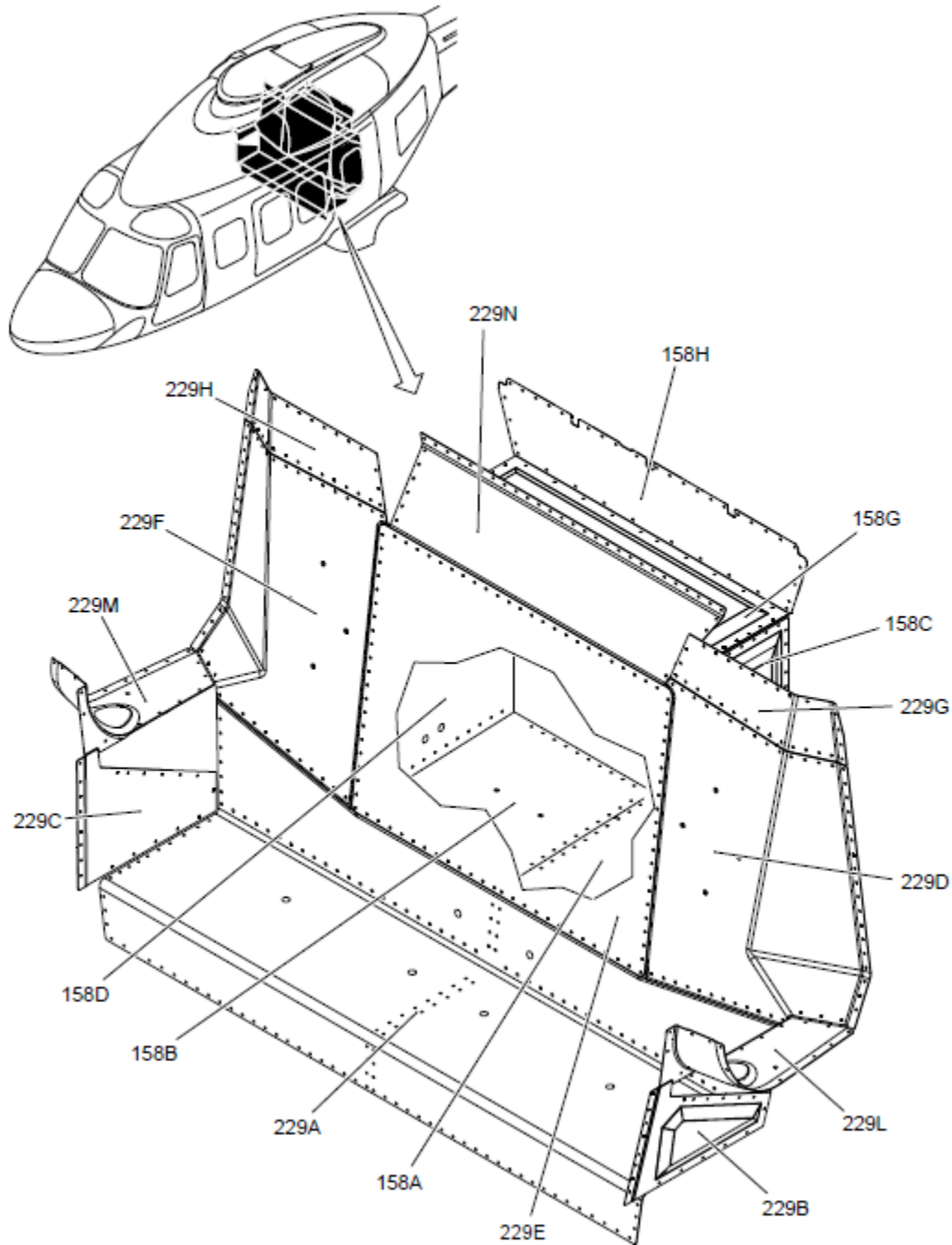

© Copyright 2024 Leonardo S.p.a.

This document contains information that is confidential and proprietary to Leonardo S.p.a. ('the Company') and is supplied on the express condition that it may not be disclosed to any third party, or reproduced in whole or in part, or used for manufacture, or used for any purpose other than for which it is supplied, without the prior written consent of the Company. Every permitted disclosure, reproduction, adaptation or publication of this document in whole or in part and in any manner or form shall prominently contain this notice

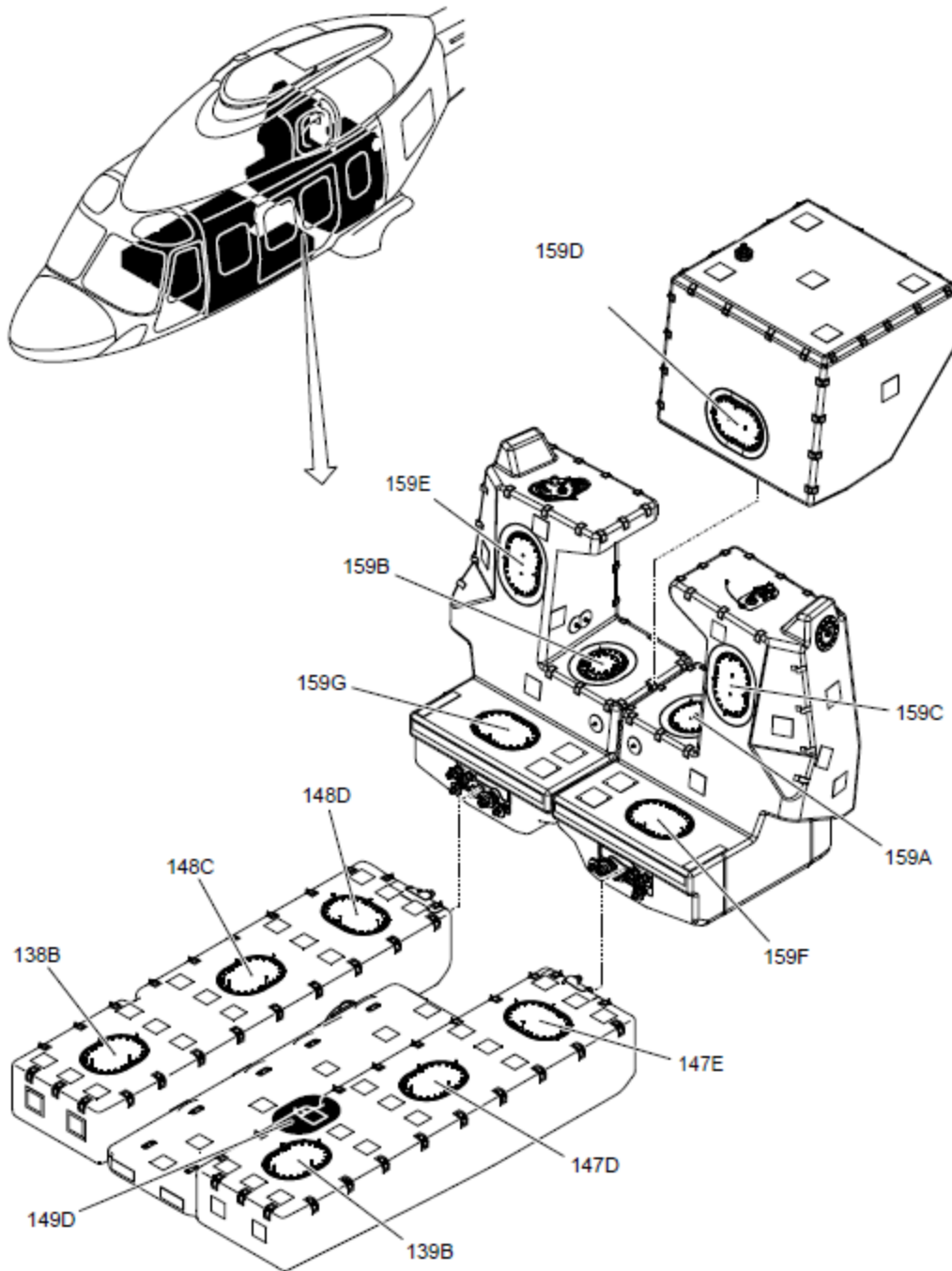

© Copyright 2024 Leonardo S.p.a.

This document contains information that is confidential and proprietary to Leonardo S.p.a. ('the Company') and is supplied on the express condition that it may not be disclosed to any third party, or reproduced in whole or in part, or used for manufacture, or used for any purpose other than for which it is supplied, without the prior written consent of the Company. Every permitted disclosure, reproduction, adaptation or publication of this document in whole or in part and in any manner or form shall prominently contain this notice

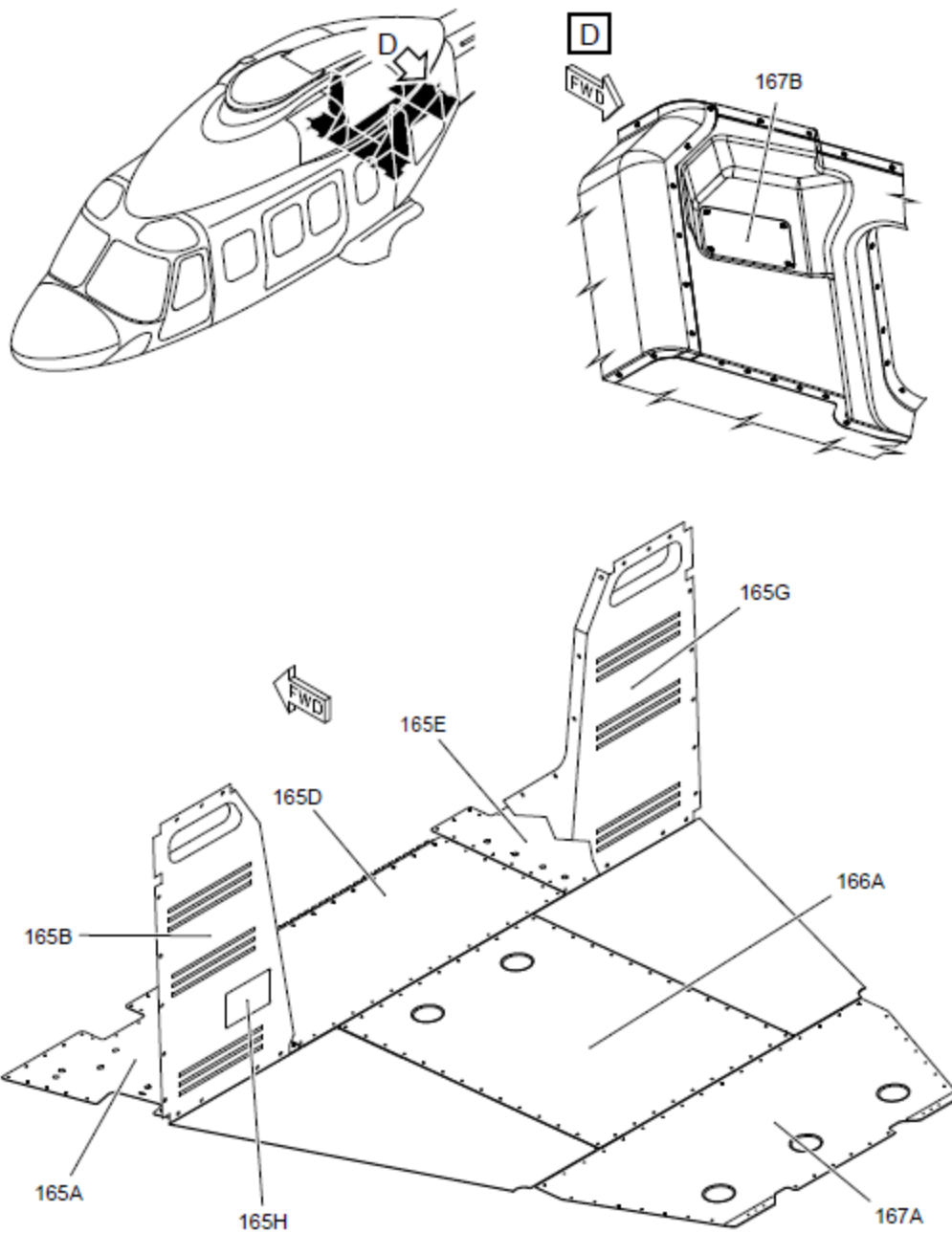

© Copyright 2024 Leonardo S.p.a.

This document contains information that is confidential and proprietary to Leonardo S.p.a. ('the Company') and is supplied on the express condition that it may not be disclosed to any third party, or reproduced in whole or in part, or used for manufacture, or used for any purpose other than for which it is supplied, without the prior written consent of the Company. Every permitted disclosure, reproduction, adaptation or publication of this document in whole or in part and in any manner or form shall prominently contain this notice



APPENDIX 3 - ADMINISTRATION

Maintenance Review Board, Industry Steering Committee and Working Group participants for AW189 MRB report.

Participants between brackets (if mentioned) are former members of the associated working body.

1 AW189 MRB memberships

Name	MRB Profile	Organisation	Function
F. Tanzi	EASA Chairperson	EASA	--

From MRBR issue I FAA participation and from MRBR is N TCCA participation in WG and ISC activities is ruled in accordance with TIP provisions.

2 AW189 ISC memberships

Up to MRBR Issue A approval;

Name	ISC Profile	Organisation	Function
G. Dossena	Chairperson	AgustaWestland	SRS Manager
L. Capacci	Co-chairman	AW / SJI	--
F. Bellardi	Member	AgustaWestland	Product Support Engineering
L. Magistri	Member	AgustaWestland	AW Maintenance Service
L. Fossati	Member	AgustaWestland	AW189 CPE Office
D. Jenkins	Member	AgustaWestland	R&M Office
Carl Eudo-Mitchell	Member	CHC	--
Chris Richards	Member	Bristow	--



After MRBR Issue A approval;

Name	ISC Profile	Organisation	Function
G. Gibilisco	Chairperson	Leonardo Helicopters	AW189 Maintainability CP
A. Piccin	Member	Leonardo Helicopters	Product Support Engineering
M. Modè C. Chirullo	Member	Leonardo Helicopters	Product Support Engineering - Publication
C. Rimoldi	Member	Leonardo Helicopters	AW189 CPE Office / WG5 Leader
Chris Richards	Member	Bristow	Operator
Abdul Rahman Bin Abdullah	Member	Westar	Operator Representative
G.Gibilisco	Member	Leonardo Helicopters	WG1,2,3, 4 and 6 Leader
S. Fiorillo	Co-chairperson	Leonardo Helicopters	AW169 Maintainability CP / AW189 Co-chairman
L. Castaldi	Member	Leonardo Helicopters	IISD Manager
A. Parente	Member	Leonardo Helicopters	Product Support Engineering



3 AW189 Working Groups and associated memberships

Basic Working Groups Allocation is as follows. However each MSI WG may be requested to address additional system related functions from ISC as a result of SSI Selection process (see paragraph 4.14).

Working Group	ATA ref.	System
WG 1	18	Vibration & noise Attenuation
	21	Environmental control (air conditioning)
	25	Equipment & Furnishing
	29	Hydraulics
	30	Ice and Rain Protection
	32	Landing Gear
	35	Oxygen
	52	Doors
	56	Windows and Canopies
	67	Fixed Flight Controls
	95	Flotation & Liferaft
	97	Image Recording
WG 2	26	Fire protection
	28	Fuel System
	44	Cabin System
	49	APU & Installation
	71	Engine Installation & Exhausts
	72	Engines
	73	Engine and Fuel Control
	74	Ignition
	75	Air
	76	Engine Controls
	77	Engine Indicating
	78	Exhaust
WG 3	22	Auto flight
	24	Electrical power & distribution



Working Group	ATA ref.	System
	25	Equipment & Furnishing (Emergency Locator Transmitter)
	23	Communications
	30	Ice and rain protection (pitot and static heating)
	31	Indicating/recording
	33	Lights
	34	Navigation
	46	Integration and display
	93	Surveillance
WG 4	62	Main rotor
	63	Main rotor drives
	64	Tail rotor
	65	Tail rotor drive
WG 5	18	Vibration & noise Attenuation
	32	Landing Gear
	49	APU & Installation (mounts only)
	52	Doors
	53	Fuselage
	55	Stabilizers
	56	Windows and Canopies
	63	Main rotor drives (Mounts only)
	65	Tail rotor drive (Mounts only)
71	Engine Installation & Exhausts (mounts only)	
WG 6	All Zones	Standard Zonal Analysis
		EZAP
	--	Lightning/HIRF Analysis

NOTE: for the purpose of the AW189 MRB Process, when analyses pertaining to ATA 55 are addressed: “Horizontal Stabilizer “and “Tail Plane” are synonymous.



Working Group membership

Up to MRBR Issue A approval;

Working Group	Name	WG Profile	Organisation	Function
WG 1	R. Webb	Leader	AW	--
	A. Carpenter	member	AgustaWestland	MSG-3 Analyst
	E. Lima	member	AgustaWestland	MSG-3 Analyst
	A. Santos	member	AgustaWestland	MSG-3 Analyst
	C. House	member	AgustaWestland	MSG-3 Analyst
	A. Masiero	member	AgustaWestland	MSG-3 Analyst
	G. Metteo	member	AgustaWestland	Engineering
	M. Pelosin	member	AgustaWestland	Product Support Engineering
	D. Turchi	member	AgustaWestland	Maintenance Service
	J. Burns	member	EASA / UKCAA	--
G. A. Bourne	Member	FAA	--	



AW189 Maintenance Review Board Report

189G0000M006

Issue V

Page App 3-6

Working Group	Name	WG Profile	Organisation	Function
WG 2	A. Masciopinto	Leader	AW	--
	A. Santos	member	AgustaWestland	MSG-3 Analyst
	A. Bebbington	member	AgustaWestland	MSG-3 Analyst
	G.Metteo	member	AgustaWestland	Engineering
	L. Zaccheddu	member	AgustaWestland	Product Support Engineering
	D.Turchi	Member	AgustaWestland	Maintenance Service
	K. Eddie	member	EASA / UKCAA	EASA Advisor
	G. A. Bourne	member	FAA	FAA Advisor
	S. Young	Member	GE Aviation, US	--
	Mark Edry	Member	GE Aviation, US	--
	Y. Basset	Member	Microturbo	--

© Copyright 2024 Leonardo S.p.a.

This document contains information that is confidential and proprietary to Leonardo S.p.a. ('the Company') and is supplied on the express condition that it may not be disclosed to any third party, or reproduced in whole or in part, or used for manufacture, or used for any purpose other than for which it is supplied, without the prior written consent of the Company. Every permitted disclosure, reproduction, adaptation or publication of this document in whole or in part and in any manner or form shall prominently contain this notice



AW189 Maintenance Review Board Report

Working Group	Name	WG Profile	Organisation	Function
WG 3	A. Smith	leader	AW	--
	A. Carpenter	member	AgustaWestland	MSG-3 Analyst
	N. Gargiulo	member	AW/SJI	MSG-3 Analyst
	A. Santos	member	AgustaWestland	MSG-3 Analyst
	C. Bebbington	member	AgustaWestland	MSG-3 Analyst
	H. Pearce	member	AgustaWestland	MSG-3 Analyst
	R. Cobb	member	AgustaWestland	MSG-3 Analyst
	R. Sadler	member	AgustaWestland	MSG-3 Analyst
	S. Peake	member	AgustaWestland	MSG-3 Analyst
	R. Pattinson	member	AgustaWestland	MSG-3 Analyst
	D. Iannucci	member	AgustaWestland	Engineering
	L. Zaccheddu	member	AgustaWestland	Product Support Engineering
	G. Belli	member	AgustaWestland	AW Maintenance Service
	S. Collu	member	AgustaWestland	AW Maintenance Service
	J. Burns	member	EASA / UKCAA	EASA Advisor
A. Rebosio	member	FAA	FAA Advisor	

© Copyright 2024 Leonardo S.p.a.

This document contains information that is confidential and proprietary to Leonardo S.p.a. ('the Company') and is supplied on the express condition that it may not be disclosed to any third party, or reproduced in whole or in part, or used for manufacture, or used for any purpose other than for which it is supplied, without the prior written consent of the Company. Every permitted disclosure, reproduction, adaptation or publication of this document in whole or in part and in any manner or form shall prominently contain this notice



AW189 Maintenance Review Board Report

189G0000M006

Issue V

Page App 3-8

Working Group	Name	WG Profile	Organisation	Function
WG 4	D. Jenkins	leader	AgustaWestland	R&M Office
	R. Webb	member	AgustaWestland	MSG-3 Analyst
	C. House	member	AgustaWestland	MSG-3 Analyst
	N. Motta	member	AgustaWestland	Engineering
	A. Comparetti	member	AgustaWestland	Engineering
	S. Dunn	member	AgustaWestland	Engineering
	A. Pagliarin	member	AgustaWestland	Product Support Engineering
	V. Castellano	member	AgustaWestland	Maintenance Service
	K. Eddie	member	EASA / UKCAA	--
	G. A. Bourne	member	FAA	--
	Stefan Dijkshoorn	Member	CHC	--
	Jerrold Seabaugh	Member	ERA Helicopters	--
	Robert Dagleish	Member	Weststar	--

© Copyright 2024 Leonardo S.p.a.

This document contains information that is confidential and proprietary to Leonardo S.p.a. ('the Company') and is supplied on the express condition that it may not be disclosed to any third party, or reproduced in whole or in part, or used for manufacture, or used for any purpose other than for which it is supplied, without the prior written consent of the Company. Every permitted disclosure, reproduction, adaptation or publication of this document in whole or in part and in any manner or form shall prominently contain this notice



AW189 Maintenance Review Board Report

Working Group	Name	WG Profile	Organisation	Function
WG 5	L. Fossati	leader	AgustaWestland	AW189 CPE Office
	A. Marson	member	AgustaWestland	MSG-3 Analyst
	D. Matthew	member	AgustaWestland	Engineering
	L. Zaccheddu	member	AgustaWestland	Product Support Engineering
	F. Sciarini	member	AgustaWestland	AW Maintenance Service
	J. Neveux	member	EASA	EASA Advisor
	G. A. Bourne	Member	FAA	FAA Advisor
	Stefan Dijkshoorn	Member	CHC	--
	Robert Dagleish	Member	Weststar	--
	Valentijn Lippens	Member	CHC	--

© Copyright 2024 Leonardo S.p.a.

This document contains information that is confidential and proprietary to Leonardo S.p.a. ('the Company') and is supplied on the express condition that it may not be disclosed to any third party, or reproduced in whole or in part, or used for manufacture, or used for any purpose other than for which it is supplied, without the prior written consent of the Company. Every permitted disclosure, reproduction, adaptation or publication of this document in whole or in part and in any manner or form shall prominently contain this notice



AW189 Maintenance Review Board Report

189G0000M006

Issue V

Page App 3-10

Working Group	Name	WG Profile	Organisation	Function
WG 6	M. Binda	leader	AgustaWestland	AW Maintenance Service
	M. Fanton	member	AW / SJI	MSG-3 Analyst
	M. Pelosin	member	AgustaWestland	Product Support Engineering
	F. Sciarini	member	AgustaWestland	AW Maintenance Service
	J. Neveux	member	EASA	EASA Advisor
	G. A. Bourne	Member	FAA	FAA Advisor
	Chris Richards	Member	Bristow	--

© Copyright 2024 Leonardo S.p.a.

This document contains information that is confidential and proprietary to Leonardo S.p.a. ('the Company') and is supplied on the express condition that it may not be disclosed to any third party, or reproduced in whole or in part, or used for manufacture, or used for any purpose other than for which it is supplied, without the prior written consent of the Company. Every permitted disclosure, reproduction, adaptation or publication of this document in whole or in part and in any manner or form shall prominently contain this notice



AW189 Maintenance Review Board Report

189G0000M006

Issue V

Page App 3-11

After MRBR Issue A approval;

Working Group	Name	WG Profile	Organisation	Function
WG 1	G. Gibilisco	Leader	Leonardo Helicopters	WG Chairman
	C. House	Member	Leonardo Helicopters	MSG-3 Analyst
	A. Piccin	Member	Leonardo Helicopters	Product Support Engineering
	D. Turchi	Member	Leonardo Helicopters	Maintenance Service
	F. Tanzi	Member	EASA	EASA MRB Chair / Advisor
	P. Ponti	Member	Leonardo Helicopters	Engineering
	F. Ricciardi	Member	Leonardo Helicopters	Engineering Avionic System Engineer
	M. Pirola	Member	Leonardo Helicopters	Engineering
	A. Scard	Member	Leonardo Helicopters	Engineering
	L. Fossati	Member	Leonardo Helicopters	Engineering
	A. Comparetti	Member	Leonardo Helicopters	Engineering
	A. Recanati	Member	Leonardo Helicopters	Engineering
	M Hawkins	Member	Leonardo Helicopters	Engineering
	A. Guercia	Member	Leonardo Helicopters	Engineering
	Chris Richards	Member	Bristow	Operator Representative
	Abdul Rahman Bin Abdullah	Member	Westar	Operator Representative
	M. Modè	Member	Leonardo Helicopters	Technical Publications
	C. Chirullo	Member	Leonardo Helicopters	Product Support Engineering (TP)
A. Sutherland	Member	Leonardo Helicopters	AW189 Airframe system Engineer	

© Copyright 2024 Leonardo S.p.a.

This document contains information that is confidential and proprietary to Leonardo S.p.a. ('the Company') and is supplied on the express condition that it may not be disclosed to any third party, or reproduced in whole or in part, or used for manufacture, or used for any purpose other than for which it is supplied, without the prior written consent of the Company. Every permitted disclosure, reproduction, adaptation or publication of this document in whole or in part and in any manner or form shall prominently contain this notice



AW189 Maintenance Review Board Report

189G0000M006

Issue V

Page App 3-12

Working Group	Name	WG Profile	Organisation	Function
WG 2	G.Gibilisco	Leader	Leonardo Helicopters	WG Chairman
	A. Piccin	Member	Leonardo Helicopters	Product Support Engineering
	M. Modè	Member	Leonardo Helicopters	Product Support Engineering
	C. Chirullo	Member	Leonardo Helicopters	Product Support Engineering (TP)
	C. Turchi	Member	Leonardo Helicopters	Maintenance Service
	F. Tanzi	Member	EASA	EASA MRB Chair / Advisor
	R. Joshua	Member	GE Aviation, US	GE focal point for MRB Process
	I. Morris	Member	Leonardo Helicopters	Engineering
	L. Creek	Member	Leonardo Helicopters	Engineering (Engine CP)
	L. Poinaut	Member	SAFRAN - Microturbo	MSG-3 Analyst (Microturbo)
	R. Ellis	Member	Leonardo Helicopters	Engineering (fuel CP)
	D. Del Gobbo	Member	Leonardo Helicopters	Engineering
	S. Fouche	Member	SAFRAN Helicopter Engine Inst.	MSG-3 Analyst
	Chris Richards	Member	Bristow	Operator Representative
	Abdul Rahman Bin Abdullah	Member	Westar	Operator Representative
A. Sutherland	Member	Leonardo Helicopters	AW189 Airframe system Engineer	

© Copyright 2024 Leonardo S.p.a.

This document contains information that is confidential and proprietary to Leonardo S.p.a. ('the Company') and is supplied on the express condition that it may not be disclosed to any third party, or reproduced in whole or in part, or used for manufacture, or used for any purpose other than for which it is supplied, without the prior written consent of the Company. Every permitted disclosure, reproduction, adaptation or publication of this document in whole or in part and in any manner or form shall prominently contain this notice



AW189 Maintenance Review Board Report

189G0000M006

Issue V

Page App 3-13

Working Group	Name	WG Profile	Organisation	Function
WG 3	G. Gibilisco	Leader	Leonardo Helicopters	WG Chairman
	M. Modè	Member	Leonardo Helicopters	Product Support Engineering
	G. Belli	Member	Leonardo Helicopters	AW Maintenance Service
	S. Collu	Member	Leonardo Helicopters	AW Maintenance Service
	F. Tanzi	Member	EASA	EASA MRB Chair / Advisor
	Chris Richards	Member	Bristow	Operator Representative
	Abdul Rahman Bin Abdullah	Member	Westar	Operator Representative
	F. Ricciardi	Member	Leonardo Helicopters	Engineering
	S. Mancin	Member	Leonardo Helicopters	Engineering
	M. Rainero	Member	Leonardo Helicopters	Engineering
	A. Piccin	Member	Leonardo Helicopters	Product Support Engineering
	C. Chirullo	Member	Leonardo Helicopters	Product Support Engineering (TP)

© Copyright 2024 Leonardo S.p.a.

This document contains information that is confidential and proprietary to Leonardo S.p.a. ('the Company') and is supplied on the express condition that it may not be disclosed to any third party, or reproduced in whole or in part, or used for manufacture, or used for any purpose other than for which it is supplied, without the prior written consent of the Company. Every permitted disclosure, reproduction, adaptation or publication of this document in whole or in part and in any manner or form shall prominently contain this notice



AW189 Maintenance Review Board Report

189G0000M006

Issue V

Page App 3-14

Working Group	Name	WG Profile	Organisation	Function
WG 4	G.Gibilisco	Leader	Leonardo Helicopters	WG Chairman
	C. House	Member	Leonardo Helicopters	MSG-3 Analyst
	M. Tamborini	Member	Leonardo Helicopters	Engineering Drive System Chief Project
	A. Comparetti	Member	Leonardo Helicopters	Engineering
	P.G. Nastuzzo	Member	Leonardo Helicopters	Engineering Rotors Chief Project
	A. Piccin	Member	Leonardo Helicopters	Product Support Engineering
	M. Modè	Member	Leonardo Helicopters	Product Support Engineering
	C. Chirullo	Member	Leonardo Helicopters	Product Support Engineering (TP)
	V. Castellano	Member	Leonardo Helicopters	Maintenance Service
	F. Tanzi	Member	EASA	EASA MRB Chair / Advisor
	Chris Richards	Member	Bristow	Operator Representative
	Abdul Rahman Bin Abdullah	Member	Westar	Operator Representative
	Jerrold Seabaugh	Member	ERA Helicopters	Operator Representative
	B. Vickers	Member	Leonardo Helicopters	Engineering Structure CP
Mohd Aiman Hilfi Bin Che Baharuddin	Member	Weststar	Operator Representative	

© Copyright 2024 Leonardo S.p.a.

This document contains information that is confidential and proprietary to Leonardo S.p.a. ('the Company') and is supplied on the express condition that it may not be disclosed to any third party, or reproduced in whole or in part, or used for manufacture, or used for any purpose other than for which it is supplied, without the prior written consent of the Company. Every permitted disclosure, reproduction, adaptation or publication of this document in whole or in part and in any manner or form shall prominently contain this notice



AW189 Maintenance Review Board Report

189G0000M006

Issue V

Page App 3-15

Working Group	Name	WG Profile	Organisation	Function
WG 5	C. Rimoldi	Leader	Leonardo Helicopters	WG Chairman
	L. Erbea	Member	Leonardo Helicopters	Engineering
	B. Vickers	Member	Leonardo Helicopters	Engineering Structure CP
	G. Tellone	Member	Leonardo Helicopters	Product Support Engineering
	F. Sciarini	Member	Leonardo Helicopters	AW Maintenance Service
	F. Tanzi	Member	EASA	EASA MRB Chair / Advisor
	C. Rimoldi	Member	Leonardo Helicopters	AW189 Project Engineer
	M. Modè	Member	Leonardo Helicopters	Product Support Engineering
	C. Chirullo	Member	Leonardo Helicopters	Product Support Engineering (TP)
	A. Piccin	Member	Leonardo Helicopters	Product Support Engineering
	Chris Richards	Member	Bristow	Operator Representative
	Abdul Rahman Bin Abdullah	Member	Westar	Operator Representative

© Copyright 2024 Leonardo S.p.a.

This document contains information that is confidential and proprietary to Leonardo S.p.a. ('the Company') and is supplied on the express condition that it may not be disclosed to any third party, or reproduced in whole or in part, or used for manufacture, or used for any purpose other than for which it is supplied, without the prior written consent of the Company. Every permitted disclosure, reproduction, adaptation or publication of this document in whole or in part and in any manner or form shall prominently contain this notice



AW189 Maintenance Review Board Report

189G0000M006

Issue V

Page App 3-16

Working Group	Name	WG Profile	Organisation	Function
WG 6	G.Gibilisco	Leader	Leonardo Helicopters	WG Chairman
	A. Piccin	Member	Leonardo Helicopters	Product Support Engineering
	F. Sciarini	Member	Leonardo Helicopters	AW Maintenance Service
	F. Tanzi	Member	EASA	EASA MRB Chair / Advisor
	M. Modè	Member	Leonardo Helicopters	Product Support Engineering (TP)
	C. Chirullo	Member	Leonardo Helicopters	Product Support Engineering(TP)
	Chris Richards	Member	Bristow	Operator Representative
	Abdul Rahman Bin Abdullah	Member	Westar	Operator Representative
	P. Williams	Member	Leonardo Helicopters	Engineering

© Copyright 2024 Leonardo S.p.a.

This document contains information that is confidential and proprietary to Leonardo S.p.a. ('the Company') and is supplied on the express condition that it may not be disclosed to any third party, or reproduced in whole or in part, or used for manufacture, or used for any purpose other than for which it is supplied, without the prior written consent of the Company. Every permitted disclosure, reproduction, adaptation or publication of this document in whole or in part and in any manner or form shall prominently contain this notice



APPENDIX 4 - DEFINITIONS

DEFINITION	EXPLANATION	SOURCE
Access External	When a specific task can be accomplished with no need to open a panel, door or other specific access. It is used when no other access is stated and when technically necessary. However during the inspection/task, external/direct access may always be applicable.	-
Accidental Damage (AD)	Physical deterioration of an item caused by contact or impact with an object or influence which is not a part of the rotorcraft, or by human error during manufacturing, operation of the rotorcraft, or maintenance practices.	MSG-3
Airworthiness Limitations	A section of the Instructions for Continued Airworthiness that contains each mandatory replacement time, structural inspection interval, and related structural inspection task. This section may also be used to define a threshold for the fatigue related inspections and the need to control corrosion to Level 1 or better. The information contained in the Airworthiness Limitations section may be changed to reflect service and/or test experience or new analysis methods.	MSG-3
Corrosion Level 1	<i>Level 1 corrosion is:</i> (1) Damage occurring between successive inspections that is within allowable damage limits; or (2) Damage occurring between successive inspections that does not require structural reinforcement, replacement or new damage tolerance based inspections; or (3) Corrosion occurring between successive inspections that exceeds allowable limits but can be attributed to an event not typical of operator usage of other aircraft in the same fleet; or (4) Light corrosion occurring repeatedly between inspections that eventually requires structural reinforcement, replacement or new damage tolerance based inspections.	IP 119 Rev. 2
Discard	The removal from service of an item at a specified life limit.	MSG-3
Economic Effects	Failure effects which do not prevent rotorcraft operation, but are economically undesirable due to added labour and material cost for rotorcraft or shop repair.	MSG-3
Electrical Wiring Interconnection System (EWIS)	An electrical connection between two or more points including the associated terminal devices (e.g. connectors, terminal blocks, splices) and the necessary means for its installation and identification.	MSG-3



DEFINITION	EXPLANATION	SOURCE
Enhanced Zonal Analysis Procedure (EZAP)	A logical procedure applicable to zones containing EWIS to identify tasks to (1) minimize accumulation of combustible materials, (2) detect EWIS component defects, and (3) detect EWIS installation discrepancies that may not be reliably detected by standard zonal inspections	IP189
Environmental Deterioration (ED)	Physical deterioration of an item's strength or resistance to failure as a result of chemical/electro-chemical interaction with its climate or environment.	MSG-3
External load cycle	An external load cycle is every external load lift using the cargo hook. NOTE: flight line maintenance checks do not count.	AW189 ALS Chapter 04
Failure	The inability of an item to perform within previously specified limits.	MSG-3
Failure Cause	Why the functional failure occurs.	MSG-3
Failure Condition	The effect on the rotorcraft and its occupants, both direct and consequential, caused or contributed to by one or more failures, considering relevant adverse operational or environmental conditions.	MSG-3
Failure Effect	What is the result of a functional failure?	MSG-3
Fatigue Damage (FD)	The initiation of a crack or cracks due to cyclic loading and subsequent propagation.	MSG-3
Fail-Safe (residual strength after flaw growth)	A structure remaining after a partial failure able to withstand design limit loads without failure within an inspection period.	CS 29



DEFINITION	EXPLANATION	SOURCE
Fretting corrosion	<p>Fretting-corrosion is a ‘mechanical corrosion’ process due to micro-motions between two parts in contact.</p> <p>Fretting corrosion is a combined wear and corrosion process in which material is removed from contact surfaces when motion between the surfaces is restricted to very small amplitude oscillation.</p> <p>The phenomenon is affected by:</p> <ul style="list-style-type: none"> • The inherent characteristics of the materials in contact. • The type of assembly used to fix the two parts. • The contact pressure between the two parts. • The presence of specific protection on one or on the two parts. <p>Fretting has not to be confused with wear, which is due to friction between two items in contact and in relevant motion.</p>	PPH
Function	The normal characteristic actions of an item.	MSG-3
Functional Check	A quantitative check to determine if one or more functions of an item performs within specified limits	MSG-3
Functional Failure	Failure of an item to perform its intended function within specified limits.	MSG-3
Hidden Function	<ol style="list-style-type: none"> 1. A function which is normally active and whose cessation or improper operation will not be evident to the operating crew during performance of normal duties. 2. A function which is normally inactive and whose readiness to perform, prior to it being needed, will not be evident to the operating crew during performance of normal duties. 	MSG-3
Hoist Lift	The external hoist lift is defined as an unreeling and recovery of the cable with a load attached to the hook, independent of the length of the cable that is deployed/recovered. An unreeling/recovery of the cable with no load on the hook is not considered to be a lift. Any operation where a load is applied for half the operation (i.e. unreeling or recovery) must be considered as one lift.	AW189 ALS Chapter 04
Inherent Level of Reliability and Safety	That level which is built into the unit and, therefore, inherent in its design. This is the highest level of reliability and safety that can be expected from a unit, system, or rotorcraft if it receives effective maintenance. To achieve higher levels of reliability generally requires modification or redesign.	MSG-3



DEFINITION	EXPLANATION	SOURCE
Inspection - Detailed (DI)	<p>An intensive examination of a specific item, installation or assembly to detect damage, failure or irregularity. This could include tactile assessment in which a component or assembly can be checked for tightness/security.</p> <p>Available lighting is normally supplemented with a direct source of good lighting at an intensity deemed appropriate. Inspection aids such as mirrors and magnifying lenses. may be necessary.</p> <p>Surface cleaning and elaborate access procedures may be required.</p>	IP122
Inspection - General Visual (GVI)	<p>A visual examination of an interior or exterior area, installation or assembly to detect obvious damage, failure or irregularity. This level of inspection is made from within touching distance, unless otherwise specified.</p> <p>A mirror may be necessary to enhance visual access to all exposed surfaces in the inspection area.</p> <p>This level of inspection is made under normally available lighting conditions such as daylight, hangar lighting, flashlight or drop-light and may require removal or opening of access panels or doors. Stands, ladders or platforms may be required to gain proximity to the area being checked.</p> <p>Basic cleaning may be required to ensure appropriate visibility.</p>	IP122
Inspection - Special Detailed (SDI)	<p>An examination of a specific item, installation, or assembly making use of specialized inspection techniques such as Non Destructive Testing (NDT) and/or equipment (e.g. boroscope, videoscope, tap test) to detect damage, failure or irregularity. Intricate cleaning and substantial access or disassembly procedures may be required.</p> <p>Classification of a task as an SDI does not define the required qualifications for the person performing the task.</p>	IP122
Inspection - Zonal	<p>A collective term comprising selected general visual inspections and visual checks that is applied to each zone, defined by access and area, to check system and power plant installations and structure for security and general condition.</p>	MSG-3
Interval (Initial - Repeat)	<p><u>Initial Interval</u> - Interval between the start of service-life and the first task accomplishment.</p> <p><u>Repeat Interval</u> - The interval (after the initial interval) between successive accomplishments of a specific maintenance task.</p>	MSG-3
Item	<p>Any level of hardware assembly (i.e., system, subsystem, module, accessory, component, unit, part, etc.).</p>	MSG-3
L/HIRF	<p>Lightning/High Intensity Radiated Field</p>	MSG-3



DEFINITION	EXPLANATION	SOURCE
L/HIRF Characteristics	Those properties of L/HIRF protection components that are necessary to perform their intended L/HIRF protection function(s).	MSG-3
L/HIRF Protection Components	Any self-contained part, combination of parts, subassemblies, units, or structures that perform a distinctive function necessary to provide L/HIRF protection.	MSG-3
L/HIRF Protection System	Systems comprised of components that avoid, eliminate, or reduce the consequences of an L/HIRF event.	MSG-3
Lubrication and Servicing	Any act of lubricating or servicing for the purpose of maintaining inherent design capabilities.	MSG-3
Maintenance Significant Item - (MSI)	Items identified by the manufacturer whose failure: <ol style="list-style-type: none"> could affect safety (on ground or in flight), and/or is undetectable during operations, and/or could have significant operational impact, and/or could have significant economic impact 	MSG-3
Main and tail rotor structure	A rotor is an assembly of rotating components, which includes the rotor hub, blades, blade dampers, the pitch control mechanisms, and all other parts that rotate with the assembly.	CS 29
Operating Crew Normal Duties: <ul style="list-style-type: none"> • Operating Crew • Normal Duties 	<p>Qualified flight compartment and cabin attendant personnel who are on duty.</p> <p>Those duties associated with the routine operation of the rotorcraft, on a daily basis, to include the following:</p> <ol style="list-style-type: none"> Procedures and checks performed during rotorcraft operation in accordance with the Rotorcraft Flight Manual. Recognition of abnormalities or failures by the operating crew through the use of normal physical senses (e.g., odour, noise, vibration, temperature, visual observation of damage or failure, changes in physical input force requirements, etc.). 	MSG-3
Operational Check	An operational check is a task to determine that an item is fulfilling its intended purpose. Does not require quantitative tolerances. This is a failure finding task.	MSG-3



DEFINITION	EXPLANATION	SOURCE
Operational Effects	Failure effects which interfere with the completion of the rotorcraft mission. These failures cause delays, cancellations, ground or flight interruptions, high drag coefficients, altitude restrictions, etc.	MSG-3
Other Structure	Structure which is judged not to be a Structural Significant Item. "Other Structure" is defined both externally and internally within zonal boundaries.	MSG-3
PSE	A Principal Structural Element is any element the failure of which could result in catastrophic failure of the rotorcraft;	CS-29
Potential Failure	A defined identifiable condition that indicates that a degradation process is taking place that will lead to a functional failure.	MSG-3
Protective Device	Any device or system that has a function to avoid, eliminate or reduce the consequences of an event or the failure of some other function.	MSG-3
Residual Strength	The strength of a damaged structure.	MSG-3
Restoration	That work necessary to return the item to a specific standard. Restoration may vary from cleaning or replacement of single parts up to a complete overhaul.	MSG-3
Rotor drive system	The rotor drive system includes any part necessary to transmit power from the engines to the rotor hubs. This includes gearboxes, shafting, universal joints, couplings, rotor brake assemblies, clutches, supporting bearings for shafting, any attendant accessory pads or drives, and any cooling fans that are a part of, attached to, or mounted on the rotor drive system.	CS 29
Safe Life	A structure able to withstand repeated loads of variable magnitude without detectable cracks for the following time intervals: (i) Life of the rotorcraft; or (ii) Within a replacement time.	CS 29
Safety (adverse effect)	Safety shall be considered as adversely affected if the consequences of the failure condition would prevent the continued safe flight and landing of the rotorcraft and/or might cause serious or fatal injury to human occupants. Including those directly supported by external load carrying systems (i.e. hoist/human cargo etc).	IP 147



DEFINITION	EXPLANATION	SOURCE
Safety/Emergency Systems or Equipment:	A device or system that: 1) enhances the evacuation of the rotorcraft in an emergency or, 2) if it does not function when required, results in a Failure Condition that might have an adverse effect on safety.	MSG-3
Structural Significant Item - (SSI)	Any detail, element or assembly, which contributes significantly to carrying flight, ground, pressure or control loads or external load and whose failure could affect the structural integrity necessary for the safety of the rotorcraft and/or might cause serious or fatal injury to human occupants. NOTE: the term "human occupants" includes people supported by external load carrying systems (i.e. hoist/human cargo etc).	IP 147
Structural Assembly	One or more structural elements which together provide a basic structural function.	MSG-3
Structural Detail	The lowest functional level in an rotorcraft structure. A discrete region or area of a structural element, or a boundary intersection of two or more elements.	MSG-3
Structural Element	Two or more structural details which together form an identified manufacturer's assembly part.	MSG-3
Structural Function	The mode of action of rotorcraft structure. It includes acceptance and transfer of specified loads in items (details /elements /assemblies) and provides consistently adequate rotorcraft response and flight characteristics.	MSG-3
Task Applicability	A set of conditions that leads to the identification of a task type when a specific set of characteristics of the failure cause being analysed would be discovered and/or corrected as a result of the task being accomplished.	MSG-3
Task Effectiveness	A specific set of conditions that leads to the selection of a task already identified to be applicable. Avoids, eliminates, or reduces the negative consequences of the failure to an extent that justifies doing the task at the selected interval.	MSG-3
Tasks - Maintenance	An action or set of actions required to achieve a desired outcome which restores an item to or maintains an item in serviceable condition, including inspection and determination of condition.	MSG-3
Threshold	See "Interval - Initial".	MSG-3



DEFINITION	EXPLANATION	SOURCE
Visual Check	A visual check is an observation to determine that an item is in its intended state. The check does not require quantitative tolerances. This is a failure finding task with obvious pass-fail criteria.	IP 143
Wear Damage	Physical deterioration of the surface of an item due to relative motion between two parts in contact.	MSG-3

**APPENDIX 5 - ABBREVIATIONS**

AC	Advisory Circular,
AD	Accidental Damage,
ALS	Airworthiness Limitation Section,
AMC	Acceptable Means of Compliance
ATA MSG-3	Air Transport Association of America Maintenance Steering Group -3rd Task Force,
AW	AgustaWestland,
CAS	Crew Alerting System,
CFE	Customer Furnished Equipment
CFR	Code of Federal Regulation,
CMM	Component Maintenance Manual,
CMR	Certification Maintenance Requirement,
CPCP	Corrosion Prevention and Control Programme,
CPE	Chief Project Engineer,
CS	Certification Specification,
CVE	Compliance Verification Engineer,
DI	Detailed Inspection,
DIS	Discard
DY	Day,
EASA	European Aviation Safety Agency,
ED	Environmental Deterioration,
EMM	Engine Maintenance Manual
EMS	Emergency Medical Service,
EWIS	Electrical Wiring Interconnection System,
EZAP	Enhanced Zonal Analysis Programme,
FAA	Federal Aviation Administration,
FC	Functional Check,
FD	Fatigue Damage,
FEC	Failure Effect Category
FH	Flight Hours,
FTS	Fuel Tank Safety
GVI	General Visual Inspection,
H/C	Helicopter,
HRS	Equipment operating hours,
HUMS	Health and Usage Monitoring System,
iaw	in accordance with,
IMRBPB	International Maintenance Review Board Policy Board
IP	Issue Paper (of IMRBPB)
ISC	Industry Steering Committee,
LHs	Leonardo Helicopters
L/HIRF	Lightning/High Intensity Radiated Field,
LRU	Line Replaceable Unit,
LU/SV	Lubrication / Servicing
MH	Month,
MMEL	Master Minimum Equipment List,
MRB	Maintenance Review Board,
MRBR	Maintenance Review Board Report,

© Copyright 2024 Leonardo S.p.a.

This document contains information that is confidential and proprietary to Leonardo S.p.a. ('the Company') and is supplied on the express condition that it may not be disclosed to any third party, or reproduced in whole or in part, or used for manufacture, or used for any purpose other than for which it is supplied, without the prior written consent of the Company. Every permitted disclosure, reproduction, adaptation or publication of this document in whole or in part and in any manner or form shall prominently contain this notice



MSI	Maintenance Significant Item,
NA	Not Applicable,
NDI	Non-Destructive Inspection,
OC	Operational Check,
PPH	Policy and Procedures Handbook,
PSE	Principal Structural Element,
Qty	Quantity,
RDSI	Rotorcraft Drive System Installation
Ref.	Reference,
Rev.	Revision,
RL	Rotorcraft landing
RST	Restoration
SAR	Search And Rescue,
SB	Service Bulletin
SDI	Special Detailed Inspection,
SL	Safe Life,
SSI	Structural Significant Item,
SYS	System,
TC	Type Certificate,
TIP	Technical Implementation Procedures,
VC	Visual Check,
WG	Working Group,
ZIP	Zonal Inspection Programme

**APPENDIX 6 - LIST OF MAINTENANCE SIGNIFICANT ITEMS (MSIs) AND STRUCTURAL SIGNIFICANT ITEMS (SSIs)**

6.1 LIST OF MSIs

MSI NUMBER	MSI TITLE
18-30-00	ACTIVE VIBRATION CONTROL SYSTEM
18-60-00	PASSIVE ATTENUATION
18-61-00	PASSIVE ATTENUATION - UNDERBELLY KIT
18-62-00	MAST VIBRATION ABSORBER KIT
21-20-00	VENTILATION
21-40-00	HEATING
21-50-00	COOLING KIT
21-60-00	TEMPERATURE CONTROLS
21-70-00	ECS DRAINS
21-71-00	AIR PURIFICATION SYSTEM
22-10-00	AUTOPILOT
23-10-00	TETRA RADIO
23-11-00	HF SPEECH COMMUNICATION KIT
23-12-00	VHF COMMUNICATIONS
23-13-00	FLEXCOMM II V/UHF RADIO
23-13-01	V/UHF TECHNISONIC TFM-550 KIT
23-14-00	GSM PHONE (PROVISIONS) KIT
23-15-00	SATCOM SKYTRACK
23-16-00	SATCOM SKYCONNECT KIT
23-17-00	VHF FM KIT
23-18-00	SATCOM DZM3 KIT
23-25-00	MIMO RADIO
23-30-00	AUDIO / VISUAL PAX ADDRESS SYSTEM KIT
23-41-00	MSI DELETED WITH MRBR IS. O
23-41-01	SINGLE POLYCON RADIO KIT
23-42-00	WIRELESS INTER-COMMUNICATION SYSTEM KIT
23-50-00	AUDIO INTEGRATING AND VOICE COMMAND SYSTEMS
23-51-00	EXTERNAL LOUDSPEAKER KIT
23-52-00	ICS - SAR CONFIGURATION KIT
24-20-00	AC GENERATION

© Copyright 2024 Leonardo S.p.a.

This document contains information that is confidential and proprietary to Leonardo S.p.a. ('the Company') and is supplied on the express condition that it may not be disclosed to any third party, or reproduced in whole or in part, or used for manufacture, or used for any purpose other than for which it is supplied, without the prior written consent of the Company. Every permitted disclosure, reproduction, adaptation or publication of this document in whole or in part and in any manner or form shall prominently contain this notice



MSI NUMBER	MSI TITLE
24-30-00	DC GENERATION
24-90-00	MULTIPURPOSE EQUIPMENT
25-10-00	FLIGHT COMPARTMENT
25-21-00	PASSENGER/OPERATING CREW
25-22-00	COCKPIT - CABIN SEPARATOR WALL KIT
25-24-00	SAR CABIN INTERIOR KIT
25-25-00	CEILING ROPE KIT
25-50-00	CARGO RESTRAINT SYSTEMS
25-61-00	ELT KIT
25-62-00	ADELT KIT
25-63-00	FIRST AID KIT
25-65-00	UNDERWATER LOCATOR BEACON KIT
25-80-00	INSULATION AND LINING
25-84-00	SEA TRAY
25-91-00	SINGLE RESCUE HOIST
25-92-00	CARGO HOOK KIT
25-93-00	DUAL RESCUE HOIST
25-98-00	CABIN CEILING RINGS
26-10-00	DETECTION
26-20-00	EXTINGUISHING
28-10-00	FUEL STORAGE
28-11-00	FUEL STORAGE UNDERBELLY TANK
28-20-00	FUEL DISTRIBUTION
28-21-00	FUEL DISTRIBUTION UNDERBELLY TANK
28-40-00	FUEL INDICATING
28-41-00	FUEL INDICATING UNDERBELLY TANK
28-70-00	FUEL DRAINS
28-80-00	FUEL VENTING
28-90-00	FUEL TANK IGNITION PREVENTION
28-90-01	FUEL TANK IGNITION PREVENTION (UNDERBELLY TANKS)
29-10-00	HYDRAULIC MAIN
29-20-00	HYDRAULIC AUXILIARY
29-30-00	INDICATING
29-70-00	HYDRAULIC DRAINS



MSI NUMBER	MSI TITLE
30-01-00	LIMITED ICE PROTECTION SYSTEM KIT
30-02-00	FULL ICE PROTECTION SYSTEM
30-20-00	AIR INTAKES
30-30-00	PITOT AND STATIC
30-40-00	WINDOWS , WINDSHIELDS, CANOPIES & DOORS
30-41-00	WINDSHIELD HEATING KIT
30-70-00	WATER DRAINS
30-80-00	ICE DETECTOR KIT
31-21-00	INDEPENDENT INSTRUMENTS STBY COMPASS
31-22-00	CLOCK
31-31-00	FLIGHT RECORDERS
31-32-00	MAINTENANCE DIAGNOSTIC SYSTEM (HUMS)
31-50-00	CENTRAL WARNING SYSTEM
32-10-00	MAIN GEAR
32-20-00	NOSE GEAR
32-30-00	EXTENSION & RETRACTION / EMERGENCY LOWERING
32-40-00	WHEELS & BRAKES
32-60-00	POSITION & WARNING
33-10-00	LIGHTING FLIGHT/COCKPIT COMPARTMENT
33-20-00	CABIN LIGHTING (HARDLINER)
33-21-00	CABIN LIGHTING KIT
33-30-00	LIGHTING CARGO AND SERVICE COMPARTMENTS
33-31-00	BAGGAGE COMPARTMENT LIGHTING KIT
33-40-00	LIGHTING EXTERIOR
33-42-00	SEARCHLIGHT
33-43-00	HOIST LIGHT KIT
33-44-00	EXTERNAL FLOOD LIGHTS KIT
33-45-00	ROTOR TIP LIGHTS KITS
33-50-00	EMERGENCY LIGHTING
34-10-00	FLIGHT ENVIRONMENT DATA
34-21-00	ISIS
34-22-00	AHRS
34-31-00	RADAR ALTIMETER
34-41-00	WEATHER RADAR



MSI NUMBER	MSI TITLE
34-42-00	HTAWS KIT
34-43-00	TCAS2 KIT
34-45-00	WEATHER / SEARCH RADAR KIT
34-51-00	NAV / VOR/ILS
34-52-00	DME
34-52-01	DUAL DME
34-54-00	DIRECTION FINDER KIT
34-55-00	TRAFFIC SURVEILLANCE SYSTEM
34-56-00	ADF
34-57-00	GPS
34-58-00	MODE S TRANSPONDER
34-59-00	AIS TRANSPONDER KIT
34-60-00	FMS
46-20-00	PROCESSING AND INTEGRATION
44-30-00	VIDEO DOWNLINK
44-50-00	CABIN MONITORING
46-21-00	CABIN MISSION CONSOLE
46-30-00	DISPLAY
49-10-00	APU MOUNTS
49-11-00	APU INLET BARRIER FILTER KIT
49-20-00	APU ENGINE
49-30-00	APU ENGINE FUEL AND CONTROL
49 40 00	APU IGNITION/STARTING
49-60-00	APU ENGINE CONTROLS
49-70-00	APU ENGINE INDICATING
49-80-00	EXHAUST
49-90-00	OIL
52-11-00	CREW
52-12-00	PASSENGER (CABIN) DOOR
52-12-01	HINGED PASSENGERS DOOR
52-30-00	CARGO
52-40-00	SERVICE DOORS
52-62-00	PASSENGER ELECTRICAL FOLDABLE FOOTSTEPS KIT
52-70-00	DOOR WARNING

© Copyright 2024 Leonardo S.p.a.

This document contains information that is confidential and proprietary to Leonardo S.p.a. ('the Company') and is supplied on the express condition that it may not be disclosed to any third party, or reproduced in whole or in part, or used for manufacture, or used for any purpose other than for which it is supplied, without the prior written consent of the Company. Every permitted disclosure, reproduction, adaptation or publication of this document in whole or in part and in any manner or form shall prominently contain this notice



MSI NUMBER	MSI TITLE
52-80-00	NOSE LANDING GEAR DOORS KIT
53-05-00	FUSELAGE DRAIN HOLE
55-10-00	STABILISER MOUNTS
56-10-00	FLIGHT COMPARTMENT
56-20-00	FUSELAGE COMPARTMENT
56-21-00	BUBBLE WINDOWS KIT
56-30-00	DOOR
62-10-00	MAIN ROTOR BLADES
62-20-00	MAIN ROTOR HEAD
62-30-00	ROTATING CONTROLS ROTOR SHAFT(S) / SWASH PLATE ASSEMBLIES
62-40-00	INDICATING
63-10-00	ENGINE/GEARBOX COUPLINGS
63-20-00	GEARBOX
63-30-00	MOUNTS, ATTACHMENT
63-40-00	INDICATING
63-51-00	ROTOR BRAKE ASSEMBLY KIT
63-52-00	ROTOR BRAKE ACTUATION SYSTEM KIT
63-53-00	ROTOR BRAKE INDICATING KIT
63-70-00	MAIN GEAR BOX OIL DRAINS
64-10-00	ROTOR BLADES
64-20-00	ROTOR HEAD
64-30-00	ROTATING CONTROLS
65-10-00	SHAFT
65-21-00	INTERMEDIATE GEARBOX
65-22-00	TAIL GEARBOX
65-40-00	INDICATING
67-11-00	COLLECTIVE PITCH ROTOR CONTROL
67-12-00	CYCLIC PITCH ROTOR CONTROL
67-13-00	MIXING CONTROL
67-20-00	ANTI-TORQUE ROTOR CONTROL (YAW CONTROL)
67-30-00	SERVO-CONTROL SYSTEM
71-20-00	ENGINE MOUNTS
71-30-00	FIRE SEALS



MSI NUMBER	MSI TITLE
71-40-00	ATTACH FITTINGS
71-50-00	ELECTRICAL HARNESS
71-60-00	AIR INTAKE
71-62-00	ENGINE INLET BARRIER FILTER KIT
71-70-00	ENGINE DRAINS
72-10-00	OUTPUT SHAFT MODULE (M04)
72-30-00	COLD SECTION MODULE
72-30-01	COMPRESSION SECTION (M01)
72-40-00	HOT SECTION MODULE
72-40-01	HOT SECTION MODULE (M02)
72-50-00	POWER TURBINE MODULE
72-50-01	POWER TURBINE MODULE (M03)
72-60-00	ACCESSORY SECTION MODULE
72-60-01	ACCESSORY GEARBOX MODULE (M05)
73-10-00	ENGINE FUEL DISTRIBUTION
73-10-01	ENGINE FUEL DISTRIBUTION
73-20-00	ENGINE CONTROLLING
73-20-01	ENGINE CONTROLLING AND INDICATING EECU
74-10-00	IGNITION ELECTRICAL POWER SUPPLY
74-10-01	IGNITION ELECTRICAL POWER SUPPLY
74-20-00	IGNITION DISTRIBUTION
74-20-01	IGNITION DISTRIBUTION
75-10-00	ENGINE ANTI-ICING
75-10-01	ENGINE ANTI-ICING
75-30-00	COMPRESSOR CONTROL
75-30-01	COMPRESSOR CONTROL
75-50-00	INLET PARTICLE SEPERATOR
76-10-00	POWER CONTROL
77-10-00	ENGINE INDICATING
78-10-00	COLLECTOR / NOZZLE
79-10-00	ENGINE LUBRICATION
79-10-01	ENGINE LUBRICATION
79-11-00	ENGINE DEBRIS WARNING SYSTEM
93-10-00	VIDEO DISTRIBUTION



MSI NUMBER	MSI TITLE
93-30-00	DIGITAL VIDEO RECORDING KIT
93-50-00	FORWARD LOOKING INFRA-RED (FLIR) KIT
93-50-01	LEONARDO ELECTRO OPTIC SURVEILLANCE SYSTEM
93-60-00	OBSTACLE PROXIMITY LIDAR SYSTEM
95-40-00	WIRE STRIKE PROTECTION KIT
95-61-00	FLOTATION KIT
95-62-00	LIFE RAFT AND LIFE JACKET KITS
97-50-00	TAIL FIN CAMERA KIT
97-51-00	CARGO CAMERA KIT
97-53-00	HOIST CAMERA KIT
97-55-00	ENHANCED VISION SYSTEM KIT



6.2 LIST OF non-MSIs

REFERENCE	TITLE
10 20	UPPER DECK MOORING KIT
23 19	SAT PHONE 9555 KIT
25.10.3	INTERSEAT CONSOL EXTENSION
25.21.05	PSNG DOOR RIGID RAIL HANDLES KIT
25.21.06	PSNG DOOR VERTICAL HANDLES KIT
25.21.12	STORAGE POCKET FOR AIRCRAFT SAFETY CARD
25.21.13	PAX DOOR VERTICAL RAILS KIT
25 81	INSULATION AND LINING PASSENGER CABIN
25 82	INSULATION AND LINING – PASSENGER CABIN SOFT-LINER KIT
25 83	INSULATION AND LINING COCKPIT
52.40.15	SPONSON STEP KIT
52 60	COCKPIT & PASSENGER CABIN FOOTSTEP KIT
71 80	ENGINE WASHING



6.3 LIST OF SSIs

SSI NUMBER	SSI TITLE
259002	HARD POINT RING ASSY
259003	HARD POINT CABIN REINFORCEMENTS
259101	SINGLE HOIST STRUCTURAL SUPPORT ASSY
259102	FUSELAGE MOUNTING PLATE ASSY
259103	DUAL HOIST STRUCTURAL SUPPORT ASSY
259105	SINGLE HOIST SUPPORT BOOM ASSY
259106	HOIST SUPPORT BASE
321001	LH MAIN LANDING GEAR ASSY
321002	RH MAIN LANDING GEAR ASSY
322001	NLG SHOCK STRUCTURE ASSY
491001	APU ATTACHMENT ASSY
521103	LH COCKPIT DOOR LOWER HINGE ASSY
521105	RH COCKPIT DOOR LOWER HINGE ASSY
521301	LH UPPER FWD HINGE-TROLLEY ASSY
521302	LH UPPER AFT HINGE-TROLLEY ASSY
521303	LH LOWER FWD HINGE-TROLLEY ASSY
521304	RH UPPER FWD HINGE-TROLLEY ASSY
521305	RH UPPER AFT HINGE-TROLLEY ASSY
521306	RH LOWER FWD HINGE-TROLLEY ASSY
530001	CABIN-REAR FUSELAGE JOINT
531001	REAR-TAIL JOINT BOLT
531002	LH MLG JOINT ASSY
531003	RH MLG JOINT ASSY
533001	LH STA5700 SIDE FRAME
533002	LH BL950 UNDER FLOOR LONGERON
533003	RH STA5700 SIDE FRAME
533004	RH BL950 UNDER FLOOR LONGERON
533101	FLOOR STRUCTURE ASSY

© Copyright 2024 Leonardo S.p.a.

This document contains information that is confidential and proprietary to Leonardo S.p.a. ('the Company') and is supplied on the express condition that it may not be disclosed to any third party, or reproduced in whole or in part, or used for manufacture, or used for any purpose other than for which it is supplied, without the prior written consent of the Company. Every permitted disclosure, reproduction, adaptation or publication of this document in whole or in part and in any manner or form shall prominently contain this notice



SSI NUMBER	SSI TITLE
533102	LH STA1785 NLG BRACKET
533103	RH STA1785 NLG BRACKET
533104	NLG ACTUATOR FITTING
533106	FLOOR STRUCTURE ASSY UNDERBELLY TANK
533201	WL1050 CABIN FLOOR PANEL
533202	CABIN FLOOR PANEL UNDERBELLY TANK
533301	UPPER STRUCTURE ASSY
533302	MGB SUPPORT STRUCTURE
533303	ENGINE SUPPORT STRUCTURE
533503	LH STA2800 FRAME ASSY
533504	RH STA2800 FRAME ASSY
533505	LH STA3800 FRAME ASSY
533506	RH STA3800 FRAME ASSY
533507	LH STA5700 FRAME REINFORCEMENT
533508	LH STA5700 MLG FITTING
533509	RH STA5700 FRAME REINFORCEMENT
533510	RH STA5700 MLG FITTING
533511	RH STA4277.5 BULKHEAD SECTOR ASSY
534001	REAR FUSELAGE SHELL
534002	REAR FUSELAGE FLOOR
534003	REAR STA8700 FRAME ASSY
534004	REAR LH LOWER FITTING
534005	REAR RH LOWER FITTING
534006	REAR LH UPPER FITTING
534007	REAR RH UPPER FITTING
535001	TAIL STA 8701 FRAME ASSY
535002	TAIL LH UPPER FITTING
535003	TAIL LH LOWER FITTING
535004	TAIL RH UPPER FITTING

© Copyright 2024 Leonardo S.p.a.

This document contains information that is confidential and proprietary to Leonardo S.p.a. ('the Company') and is supplied on the express condition that it may not be disclosed to any third party, or reproduced in whole or in part, or used for manufacture, or used for any purpose other than for which it is supplied, without the prior written consent of the Company. Every permitted disclosure, reproduction, adaptation or publication of this document in whole or in part and in any manner or form shall prominently contain this notice



SSI NUMBER	SSI TITLE
535005	TAIL RH LOWER FITTING
535006	TAIL CONE
535007	TAIL FIN
535008	TGB FITTING
535009	IGB ATTACHMENT
535010	TAILPLANE UPPER FITTING ASSY
535011	TAILPLANE LOWER FITTING
551001	TAILPLANE ROD ASSY
551002	TAILPLANE FITTING ASSY
551003	TAIL PLANE ASSY
633001	LH FWD STRUT ASSY
633002	RH FWD STRUT ASSY
633003	LH AFT STRUT ASSY
633004	RH AFT STRUT ASSY
633005	MGB STRUT FIXING BOLT
633006	MGB LH FWD BRACKET ASSY
633007	MGB RH FWD BRACKET ASSY
633008	MGB LH REAR BRACKET ASSY
633009	MGB RH REAR BRACKET ASSY
633010	ANTI-TORQUE BEAM ASSY
633011	ANTI-TORQUE BEAM BOLT
712001	PORT ENGINE SUPPORT JOINT
712002	PORT ENGINE SUPPORT BRACKET
712003	STARBOARD ENGINE SUPPORT JOINT
712004	STARBOARD ENGINE SUPPORT BRACKET
712005	PORT / STARBOARD ENGINE SUPPORT BEAM ASSY
713006	APU STRUT ASSY



6.4 LIST OF OTHER STRUCTURE

STRUCTURE NUMBER	TITLE
100001	KIT MOORING
183001	KIT ACTIVE VIBRATION CONTROL SYSTEM
186001	LH VIBRATION PASSIVE ATTEN ASSY
186002	RH VIBRATION PASSIVE ATTEN ASSY
186003	LH AFT VIBRATION PASSIVE ATTEN ASSY
186004	RH AFT PASSIVE VIBRATION ATTEN ASSY
186005	LH FWD PAV ASSY UNDERBELLY TANK
186006	RH FWD PAV ASSY UNDERBELLY TANK
186007	LH AFT PAV ASSY UNDERBELLY TANK
186008	RH AFT PAV ASSY UNDERBELLY TANK
259001	KIT PASSENGER DOOR HARD POINTS
259202	CARGO HOOK STRUCTURAL PROVISION
259203	CARGO HOOK STRUCTURAL PROVISION UNDERBELLY TANK
334001	SEARCHLIGHT BOOM INSTL UNDERBELLY TANK
334002	SEARCHLIGHT PROVISIONS UNDERBELLY TANK
521101	PILOT/CO-PILOT DOOR INSTL
521102	LH UPPER HINGE ASSY
521104	RH UPPER HINGE ASSY
521201	LH PASSENGER DOOR INSTL
521202	RH PASSENGER DOOR INSTL
521203	LH HINGED PASSENGER DOOR ASSY
521204	RH HINGED PASSENGER DOOR ASSY
521307	LH UPPER PASSENGER DOOR HINGE
521308	LH LOWER PASSENGER DOOR HINGE
521309	RH UPPER PASSENGER DOOR HINGE
521310	Rh LOWER P PASSENGER DOOR HINGE
523001	LH BAGGAGE DOOR INSTL

© Copyright 2024 Leonardo S.p.a.

This document contains information that is confidential and proprietary to Leonardo S.p.a. ('the Company') and is supplied on the express condition that it may not be disclosed to any third party, or reproduced in whole or in part, or used for manufacture, or used for any purpose other than for which it is supplied, without the prior written consent of the Company. Every permitted disclosure, reproduction, adaptation or publication of this document in whole or in part and in any manner or form shall prominently contain this notice



STRUCTURE NUMBER	TITLE
523002	RH BAGGAGE DOOR INSTL
524001	NOSE RADOME INSTL
526001	LH FOOTSTEP ASSY
526002	RH FOOTSTEP ASSY
526003	LH FOLDABLE FOOTSTEP INSTL
526004	RH FOLDABLE FOOTSTEP INSTL
526005	PASSENGER FOLDABLE FOOTSTEPS STRUCTURAL PROVISION
526006	PASSENGER FOLDABLE FOOTSTEP FAIRINGS INST.
526007	PASSENGER FOLDABLE FOOTSTEP ACTUATORS INST.
520608	COCKPIT FOOTSTEPS INST.
532001	CANOPY PRIMARY STRUCTURE ASSY
531004	HINGED PASSENGER DOOR STRUCTURAL PROVISION
533005	FUEL COMPARTMENT
533006	LH PASSENGER DOOR RAIL INSTL
533007	RH PASSENGER DOOR RAIL INSTL
533105	NOSE STRUCTURE ASSY
533501	LH SIDEWALL PANEL ASSY
533502	RH SIDEWALL PANEL ASSY
533901	MLG SPONSON INSTL
534008	REAR COWLING BRACKET INSTL
535012	MANHOLE COVER INSTL
535501	TAIL ROTOR SHAFT COWLING INSTL
535502	TRAILING EDGE FAIRING INSTL
535503	LEADING EDGE FAIRING INSTL
535504	TAIL GEARBOX FAIRING INSTL
535505	INTERMEDIATE GEARBOX COVER INSTL
561001	UPPER TRANSPARENT INSTL
561002	LOWER TRANSPARENT INSTL



STRUCTURE NUMBER	TITLE
561003	WINDSHIELD INSTL 4+3 ACRYLIC
561004	KIT GLASS WINDSHIELD
563001	PASSENGER CABIN TRANSPARENT INSTL
711001	LH ENGINE AIR INTAKE FRAME ASSY
711002	RH ENGINE AIR INTAKE FRAME ASSY
711003	LH NACA INTAKE COWLING INSTL
711004	RH NACA INTAKE COWLING INSTL
711005	FWD SLIDING COWLING INSTL
711006	FWD COWLING RAIL INSTL
711007	REAR SLIDING COWLING ASSY
711008	PROVISION REAR COWLING INSTL
711009	LH ENGINE COWLING ASSY
711010	RH ENGINE COWLING ASSY
711011	APU COWLING ASSY
713001	FIREWALL INSTALLATION
713002	LH AFT ENGINE COWLING BRACKET
713003	RH AFT ENGINE COWLING BRACKET
713004	LH FWD ENGINE COWLING BRACKET
713005	RH FWD ENGINE COWLING BRACKET
716001	LH ENGINE AIR INTAKE INSTL
716002	RH ENGINE AIR INTAKE INSTL
935001	FLIR SAFIRE 380-HD PROVISION UNDERBELLY TANK



6.5 LIST OF MSIs WITHOUT TASK SELECTED

REVISION STATUS	MSI NUMBER	MSI DESCRIPTION	FEC	APPLICABILITY	
				AW189	AW189ER
ATA 18: VIBRATION & NOISE ANALYSIS & ATTENUATION					
	18-30-00	ACTIVE VIBRATION CONTROL KIT	6 ; 9	YES	YES
	18-60-00	PASSIVE ATTENUATION	9	YES	NO
ATA 21: AIR CONDITIONING					
	21-20-00	TASKS ADDED WITH MRBR ISSUE F	-	-	-
	21-50-00	COOLING KIT	6; 9	YES	YES
	21-60-00	TEMPERATURE CONTROL	6 ; 9	YES	YES
	21-70-00	ECS DRAINS	9	YES	YES
	21-71-00	AIR PURIFICATION	9	YES	YES
ATA 23: COMMUNICATIONS					
	23-10-00	TETRA RADIO	9	YES	YES
	23-11-00	HF SPEECH COMMUNICATION KIT	9	YES	YES
	23-12-00	VHF COMMUNICATIONS	6 ; 9	YES	YES
	23-13-00	V/UHF KIT	9	YES	YES
	23-13-01	TECHNISONIC TFM-550 V/UHF RADIO KIT	9	YES	YES
N	23-13-02	RT7000 REMOTE MOUNTED RADIO KIT	9	YES	YES
	23-14-00	RADIO PROVISIONINGKITS	9	YES	YES
	23-15-00	TASKS ADDED WITH MRBR ISSUE E	-	-	-
	23-16-00	SATCOM SKYCONNECT KIT	9	YES	YES
	23-17-00	VHF FM KIT	9	YES	YES
	23-18-00	IRIDIUM FLIGHTCELL SATCOM	9	YES	YES
	23-25-00	MIMO RADIO	9	YES	YES



AW189 Maintenance Review Board Report

189G0000M006

Issue V

Page App 6-16

REVISION STATUS	MSI NUMBER	MSI DESCRIPTION	FEC	APPLICABILITY	
				AW189	AW189ER
	23-41-00	MSI DELETED WITH MRBR IS. O	-	-	-
	23-41-01	SINGLE POLYCON RADIO KIT	6 ; 9	YES	YES
	23-42-00	WIRELESS INTER-COMMUNICATIONS SYSTEM KIT	9	YES	YES
	23-51-00	EXTERNAL LOUDSPEAKER	9	YES	YES
ATA 24: ELECTRIC POWER					
	24-90-00	MULTIPURPOSE EQUIPMENT	6 ; 9	YES	YES
ATA 25: EQUIPMENT / FURNISHING					
	25-22-00	COCKPIT - CABIN SEPARATOR WALL KIT	9	YES	YES
ATA 28: FUEL					
	28-40-00	FUEL INDICATING	6 ; 9	YES	NO
	28-41-00	FUEL INDICATING UNDERBELLY TANK	6 ; 9	NO	YES
	28-70-00	FUEL DRAINS	9	YES	YES
ATA 29: HYDRAULIC POWER					
	29-20-00	HYDRAULIC AUXILIARY	6 ; 9	YES	YES
	29-70-00	HYDRAULIC DRAINS	9	YES	YES
ATA 30: ICE AND RAIN PROTECTION					
	30-20-00	TASKS ADDED WITH MRBR ISSUE F	-	-	-
	30-30-00	PITOT AND STATIC	6	YES	YES
	30-41-00	HEATED WINDSHIELDS KIT	6 ; 9	YES	YES
	30-80-00	ICE DETECTOR KIT	9	YES	YES
ATA 31: INDICATING / RECORDING SYSTEMS					
	31-22-00	CLOCK	6 ; 9	YES	YES
	31-32-00	MAINTENANCE DIAGNOSTIC SYSTEM (HUMS)	9	YES	YES

© Copyright 2024 Leonardo S.p.a.

This document contains information that is confidential and proprietary to Leonardo S.p.a. ('the Company') and is supplied on the express condition that it may not be disclosed to any third party, or reproduced in whole or in part, or used for manufacture, or used for any purpose other than for which it is supplied, without the prior written consent of the Company. Every permitted disclosure, reproduction, adaptation or publication of this document in whole or in part and in any manner or form shall prominently contain this notice



AW189 Maintenance Review Board Report

189G0000M006

Issue V

Page App 6-17

REVISION STATUS	MSI NUMBER	MSI DESCRIPTION	FEC	APPLICABILITY	
				AW189	AW189ER
	31-50-00	CENTRAL WARNING SYSTEM	6	YES	YES
ATA 33: LIGHTS					
	33-20-00	CABIN LIGHTING HARDLINER (HL)	9	YES	YES
	33-21-00	CABIN LIGHTING KIT	9	YES	YES
	33-30-00	LIGHTING CARGO AND SERVICE COMPARTMENTS	9	YES	YES
	33-31-00	BAGGAGE COMPARTMENT LIGHTING KIT	9	YES	YES
	33-40-00	EXTERIOR LIGHTNING	9	YES	YES
	33-43-00	HOIST LIGHTING KIT	9	YES	YES
	33-44-00	HOVER LIGHTS KIT	9	YES	YES
	33-45-00	ROTOR TIP LIGHTS KIT	9	YES	YES
ATA 34: NAVIGATION					
	34-21-00	TASKS ADDED WITH MRBR ISSUE C	-	-	-
	34-31-00	RADAR ALTIMETER	6 ; 9	YES	YES
	34-41-00	WEATHER RADAR KIT	6 ; 9	YES	YES
	34-42-00	HTAWS KIT	6	YES	YES
	34-43-00	TCAS2 KIT	6	YES	YES
	34-45-00	WEATHER / SEARCH RADAR KIT	6 ; 9	YES	YES
	34-51-00	NAV / VOR / ILS	6 ; 9	YES	YES
	34-52-00	DME	6 ; 9	YES	YES
	34-52-01	DUAL DME	6 ; 9	YES	YES
	34-54-00	DIRECTION FINDER KIT	9	YES	YES
	34-55-00	TRAFFIC SURVEILLANCE SYSTEM	6 ; 7 ; 9	YES	YES
	34-56-00	ADF	6 ; 9	YES	YES
	34-57-00	GPS	6 ; 9	YES	YES

© Copyright 2024 Leonardo S.p.a.

This document contains information that is confidential and proprietary to Leonardo S.p.a. ('the Company') and is supplied on the express condition that it may not be disclosed to any third party, or reproduced in whole or in part, or used for manufacture, or used for any purpose other than for which it is supplied, without the prior written consent of the Company. Every permitted disclosure, reproduction, adaptation or publication of this document in whole or in part and in any manner or form shall prominently contain this notice



AW189 Maintenance Review Board Report

189G0000M006

Issue V

Page App 6-18

REVISION STATUS	MSI NUMBER	MSI DESCRIPTION	FEC	APPLICABILITY	
				AW189	AW189ER
	34-58-00	MODE S TRANSPONDER	6 ; 9	YES	YES
	34-59-00	AUTOMATIC IDENTIFICATION SYSTEM (AIS) TRANSPONDER KIT	6 ; 9	YES	YES
	34-60-00	FLIGHT MANAGEMENT COMPUTING (FMS)	6 ; 9	YES	YES
ATA 44: CABIN SYSTEMS					
	44-30-00	VIDEO DOWNLINK	9	YES	NO
	44-50-00	CABIN MONITORING	9	YES	YES
ATA 46: SYSTEMS INTEGRATION AND DISPLAY					
	46-21-00	CABIN MISSION CONSOLE	6 ; 9	YES	YES
ATA 49: AIRBORNE AUXILIARY POWER					
	49-60-00	APU CONTROLS	6 ; 9	YES	YES
	49-70-00	APU INDICATING	6 ; 9	YES	YES
ATA 53: FUSELAGE					
	53-05-00	FUSELAGE DRAIN HOLES	9	YES	YES
ATA 56: WINDOWS AND CANOPIES					
	56-30-00	DOOR	6 ; 9	YES	YES
ATA 62: MAIN ROTOR					
	62-40-00	INDICATING	9	YES	YES
ATA 63: MAIN ROTOR DRIVE					
	63-53-00	ROTOR BRAKE INDICATING KIT	6 ; 9	YES	YES
	63-70-00	MAIN GEARBOX OIL DRAINS	9	YES	YES
ATA 71: POWER PLANT INSTALLATION					
	71-50-00	ELECTRICAL HARNESS	6 ; 9	YES	YES
ATA 73: ENGINE FUEL AND CONTROL					
	73-20-00	ENGINE CONTROLLING	6	WITH CT7-2E1 ENGINE	WITH CT7-2E1 ENGINE

© Copyright 2024 Leonardo S.p.a.

This document contains information that is confidential and proprietary to Leonardo S.p.a. ('the Company') and is supplied on the express condition that it may not be disclosed to any third party, or reproduced in whole or in part, or used for manufacture, or used for any purpose other than for which it is supplied, without the prior written consent of the Company. Every permitted disclosure, reproduction, adaptation or publication of this document in whole or in part and in any manner or form shall prominently contain this notice



AW189 Maintenance Review Board Report

189G0000M006

Issue V

Page App 6-19

REVISION STATUS	MSI NUMBER	MSI DESCRIPTION	FEC	APPLICABILITY	
				AW189	AW189ER
				INSTALLATION	INSTALLATION
ATA 74: IGNITION					
	74-10-00	IGNITION ELECTRICAL POWER SUPPLY	6; 9	WITH CT7-2E1 ENGINE INSTALLATION	WITH CT7-2E1 ENGINE INSTALLATION
	74-10-01	IGNITION ELECTRICAL POWER SUPPLY	6	WITH ANETO-1K ENGINE INSTALLATION	NO
ATA 76: ENGINE CONTROLS					
	76-10-00	POWER CONTROL	6; 9	YES	YES
ATA 77: ENGINE INDICATING					
	77-00-00	ENGINE INDICATING	6	YES	YES
ATA 93: SURVEILLANCE					
	93-10-00	VIDEO DISTRIBUTION	9	YES	YES
	93-30-00	VIDEO RECORDING	9	YES	YES
ATA 97: IMAGE RECORDING					
	97-50-00	TAIL FIN CAMERA KIT	9	YES	YES
	97-51-00	CARGO CAMERA KIT	6; 9	YES	YES
	97-53-00	HOIST CAMERA KIT	9	YES	YES
	97-55-00	ENHANCED VISION SYSTEM KIT	9	YES	YES

© Copyright 2024 Leonardo S.p.a.

This document contains information that is confidential and proprietary to Leonardo S.p.a. ('the Company') and is supplied on the express condition that it may not be disclosed to any third party, or reproduced in whole or in part, or used for manufacture, or used for any purpose other than for which it is supplied, without the prior written consent of the Company. Every permitted disclosure, reproduction, adaptation or publication of this document in whole or in part and in any manner or form shall prominently contain this notice



6.6 LIST OF SSIs WITHOUT TASK SELECTED

REVISION STATUS	SSI NUMBER	SSI DESCRIPTION	APPLICABILITY		ZONE
			AW189	AW189ER	
ATA 53: FUSELAGE					
	53-00-01	CABIN-REAR FUSELAGE JOINT	YES	YES	150 ; 160
	53-35-03	LH STA2800 FRAME ASSY	YES	YES	220
	53-35-04	RH STA2800 FRAME ASSY	YES	YES	220
	53-35-11	RH STA4277.5 BULKHEAD SECTOR ASSY	YES	YES	180
	53-50-10 53-50-11	TAILPLANE UPPER/LOWER FITTING ASSY	YES	YES	323
ATA 71:ENGINE INSTALLATION					
	71-30-06	APU STRUT ASSY	YES	YES	460



6.7 LIST OF GENERAL VISUAL INSPECTIONS (GVI) SATISFIED BY ZONAL INSPECTIONS

6.7.1 LIST OF GVI TASKS (MSI) SATISFIED BY ZONAL INSPECTIONS

REV. STATUS	MSG-3 TASK REF	TASK TITLE	APPLICABILITY		ORIGINAL TASK INTERVAL	FEC	MRBR ZONAL TASK REFERENCE	ORIGINAL ZONAL TASK INTERVAL	REMARKS
			AW189	AW189ER					
	252100-06	GENERAL VISUAL INSPECTION OF CABIN GRAB HANDLES	AW189 WITH CABIN GRAB HANDLES KIT	AW189 WITH CABIN GRAB HANDLES KIT	2 YR	9	200220Z-02 200220Z-03	2 YR 1 YR	-
R	252500-01	GENERAL VISUAL INSPECTION OF CABIN CEILING ROPE.	WITH CEILING ROPE INSTALLED	WITH CEILING ROPE INSTALLED	2 YR	6	200220Z-02	2 YR	-
	523000-02	GENERAL VISUAL INSPECTION OF CARGO DOOR LATCHES AND HINGES.	YES	YES	3200 FH / 4 YR	6	200160Z-01	2 YR	-
	524000-01	GENERAL VISUAL INSPECTION OF APU PANEL HINGES AND LATCHES.	YES	YES	3200 FH / 4 YRS	6	200460Z-01	6 MH	-
	524000-02	GENERAL VISUAL INSPECTION OF DC EXT PWR DOOR HINGES AND LATCHES.	YES	YES	3200 FH / 4 YRS	6	200100Z-01	1 Y	-
	524000-03	GENERAL VISUAL INSPECTION OF AC EXT PWR DOOR HINGES AND LATCHES.	YES	YES	3200 FH / 4 YRS	6	200100Z-01	1 Y	-
	524000-04	TASK INCLUSION REASSESSED IN MRBR ISSUE L	-	-	-	-	-	-	-
	524000-05	GENERAL VISUAL INSPECTION OF NOSE DOOR	YES	YES	3200 FH / 4 YRS	6	200111Z-01	1 Y	-

© Copyright 2024 Leonardo S.p.a.

This document contains information that is confidential and proprietary to Leonardo S.p.a. ('the Company') and is supplied on the express condition that it may not be disclosed to any third party, or reproduced in whole or in part, or used for manufacture, or used for any purpose other than for which it is supplied, without the prior written consent of the Company. Every permitted disclosure, reproduction, adaptation or publication of this document in whole or in part and in any manner or form shall prominently contain this notice



AW189 Maintenance Review Board Report

189G0000M006

Issue V

Page App 6-22

REV. STATUS	MSG-3 TASK REF	TASK TITLE	APPLICABILITY		ORIGINAL TASK INTERVAL	FEC	MRBR ZONAL TASK REFERENCE	ORIGINAL ZONAL TASK INTERVAL	REMARKS
			AW189	AW189ER					
		HINGES AND LATCHES.							
	524000-06	GENERAL VISUAL INSPECTION OF ENGINE ACCESS PANEL HINGES AND LATCHES.	YES	YES	3200 FH / 4 YRS	9	200460Z-01	6 MH	-
	524000-07	TASK INCLUSION REASSESSED IN MRBR ISSUE L	-	-	-	-	-	-	-
	524000-08	TASK INCLUSION REASSESSED IN MRBR ISSUE L	-	-	-	-	-	-	-
	671100-03	GVI OF COCKPIT COLLECTIVE CONTROLS GAITERS	YES	YES	2 YR	6	200210Z-01	2 YR	-
	671200-03	GENERAL VISUAL INSPECTION OF CYCLIC COCKPIT CONTROLS GAITERS	YES	YES	2 YR	6	200210Z-01	2 YR	-
	714000-01	GENERAL VISUAL INSPECTION OF THE IPS DUCT AND V-CLAMPS, PLUS STARTER/GENERATOR DUCT AND V-CLAMP	YES	YES	1600 FH	9	200460Z-01	6 MH	-

© Copyright 2024 Leonardo S.p.a.

This document contains information that is confidential and proprietary to Leonardo S.p.a. ('the Company') and is supplied on the express condition that it may not be disclosed to any third party, or reproduced in whole or in part, or used for manufacture, or used for any purpose other than for which it is supplied, without the prior written consent of the Company. Every permitted disclosure, reproduction, adaptation or publication of this document in whole or in part and in any manner or form shall prominently contain this notice



6.8 LIST OF ZONES NOT COVERED BY ZONAL INSPECTIONS

The following zones are not specified in Section E nor Section C:

REVISION STATUS	ZONE NUMBER	ZONE TITLE	APPLICABILITY		SURVEILLANCE BY / COMMENTS
			AW189	AW189ER	
	330 - 340	TAIL PLANE (INTERNAL)	YES	YES	CLOSED ZONE CONTAINING ONLY STRUCTURE WITH EXCEPTION OF A SINGLE LOW ENERGY WIRE ON EACH SIDE WELL PROTECTED BY A DEDICATED CONDUIT

**APPENDIX 7- DELETED TASK LIST**

TASK REFERENCE	DELETED BY MRBR ISSUE	REASON
186002S-01	O	TASK DELETED BECAUSE SSI HAS BEEN RECLASSIFIED AS OTHER STRUCTURES
186002S-02	O	TASK DELETED BECAUSE SSI HAS BEEN RECLASSIFIED AS OTHER STRUCTURES
186200M-01	E	TASK DELETED BECAUSE COVERED BY 186200M-02
215000M-01	L	TASK DELETED IN ACCORDANCE WITH REVISED ANALYSIS
231500M-02	H	TASK DELETED IN ACCORDANCE WITH REVISED ANALYSIS
242000M-03	G	TASK DELETED IN ACCORDANCE WITH REVISED ANALYSIS
243000M-04	G	TASK DELETED IN ACCORDANCE WITH REVISED ANALYSIS
251000M-04	B	TASK DELETED BECAUSE COVERED BY 251000M-03
252100M-04	B	TASK DELETED BECAUSE COVERED BY 252100M-03
252400M-01	P	TASK DELETED BECAUSE COVERED BY 252100M-06
252400M-02	P	TASK DELETED BECAUSE COVERED BY 252100M-07
252400M-03	P	TASK DELETED BECAUSE COVERED BY 252100M-05
252400M-04	P	TASK DELETED BECAUSE COVERED BY 252100M-02
252400M-05	P	TASK DELETED BECAUSE COVERED BY 252100M-03
252400M-06	P	TASK DELETED BECAUSE COVERED BY 252100M-08
252400M-07	P	TASK DELETED BECAUSE COVERED BY 252100M-09
252400M-08	P	TASK DELETED BECAUSE COVERED BY 252100M-10
284000M-01	B	FUEL LOW LEVEL SENSOR IS MONITORED BY CBIT
256200M-08	C	TASK DELETED BECAUSE COVERED BY 256200M-07

© Copyright 2024 Leonardo S.p.a.

This document contains information that is confidential and proprietary to Leonardo S.p.a. ('the Company') and is supplied on the express condition that it may not be disclosed to any third party, or reproduced in whole or in part, or used for manufacture, or used for any purpose other than for which it is supplied, without the prior written consent of the Company. Every permitted disclosure, reproduction, adaptation or publication of this document in whole or in part and in any manner or form shall prominently contain this notice



AW189 Maintenance Review Board Report

TASK REFERENCE	DELETED BY MRBR ISSUE	REASON
259100M-09	C	TASK DELETED BECAUSE COVERED BY 259100M-10
259300M-09	C	TASK DELETED BECAUSE COVERED BY 259300M-10
262000M-01	N	TASK DELETED IN ACCORDANCE WITH REVISED ANALYSIS CONSIDERING IP 185.
281000M-02	S	TASK DELETED IN ACCORDANCE WITH REVISED ANALYSIS
300200M-08	H	TASK DELETED BECAUSE COVERED BY 300200M-10
321000M-03	E	TASK NO MORE APPLICABLE FOLLOWING REVIEW OF MAIN LANDING GEAR TASK EFFECTIVENESS
334200M-01	L	TASK DELETED BECAUSE COVERED BY 334200M-12
334200M-02	C	TASK NO MORE APPLICABLE FOLLOWING COMPLETE REVIEW OF SEARCHLIGHT TASKS
334200M-03	C	TASK NO MORE APPLICABLE FOLLOWING COMPLETE REVIEW OF SEARCHLIGHT TASKS
334200M-04	C	TASK DELETED BECAUSE COVERED BY 334200M-01
334200M-05	C	TASK NO MORE APPLICABLE FOLLOWING COMPLETE REVIEW OF SEARCHLIGHT TASKS
334200M-06	L	TASK DELETED IN ACCORDANCE WITH REVISED ANALYSIS
334200M-09	C	TASK NO MORE APPLICABLE FOLLOWING COMPLETE REVIEW OF SEARCHLIGHT TASKS
334200M-11	L	TASK DELETED IN ACCORDANCE WITH REVISED ANALYSIS
523000M-01	C	GVI COVERED BY ZONAL INSPECTION
524000M-01	C	GVI COVERED BY ZONAL INSPECTION
524000M-02	C	GVI COVERED BY ZONAL INSPECTION
535010S-01	F	TASK DELETED IN ACCORDANCE WITH NEW SSI ANALYSIS (NEW TAILPLANE FITTINGS MATERIAL)
535010S-02	F	TASK DELETED IN ACCORDANCE WITH NEW SSI ANALYSIS (NEW TAILPLANE FITTINGS MATERIAL)
561000M-01	B	DISCARD (561000M-02 AND -03) OF THE EMERGENCY EXIT WINDOW SEALS REPLACES OC OF WINDOW SEALS (561000M-01)



AW189 Maintenance Review Board Report

TASK REFERENCE	DELETED BY MRBR ISSUE	REASON
562000M-01	B	DISCARD (562000M-02 AND -03) OF THE EMERGENCY EXIT WINDOW SEALS REPLACES OC OF WINDOW SEALS (562000M-01)
621000M-07	D	TASK DELETED BECAUSE NO MORE APPLICABLE (KIT CANCELLED)
641000M-11	D	TASK DELETED BECAUSE NO MORE APPLICABLE (KIT CANCELLED)
634000M-05	C	TASK DELETED BECAUSE COVERED BY 634000M-02
637000M-01	B	TASK DELETED BECAUSE COVERED BY 307000M-01
643000M-06	U	TASK DELETED BECAUSE COVERED BY 643000M-02
643000M-07	U	TASK DELETED BECAUSE COVERED BY 643000M-02
654000M-06	C	TASK DELETED BECAUSE COVERED BY 654000M-05
673000M-08	D	TASK DELETED BECAUSE COVERED BY 673000M-01
671100M-03	C	GVI COVERED BY ZONAL INSPECTION
671200M-03	C	GVI COVERED BY ZONAL INSPECTION
714000M-01	C	GVI COVERED BY ZONAL INSPECTION
956100M-05	C	TASK NO MORE APPLICABLE FOLLOWING COMPLETE REVIEW OF FLOTATION TASKS
956100M-07	D	TASK DELETED IN ACCORDANCE WITH NEW TEST RESULTS



APPENDIX 8 - STRUCTURAL INSPECTIONS REPORTING SYSTEM

A Structural Inspection report shall be used by Operators / maintenance organizations to report structural inspection results to the rotorcraft manufacturer.

The following rules apply to the reporting:

- 1) A completed Structural Inspection report is required any time a structurally significant defect occurs.
- 2) The responsibility for reporting remains with the Operator.
- 3) Corrosion findings level 2 or 3 must be reported as per CPCP standard rules

The format of Structural Inspection Report is not strictly fixed, hereafter the list of information which should be provided as necessary in the report:

DESCRIPTION	COMMENT
Operator	Operator's code (ICAO)
Maintenance and Repair Organization	Maintenance and Repair Organization title
Manufacturer Serial Number	Rotorcraft Manufacturer Serial Number (MSN)
Tail Number / Registration	Rotorcraft Tail Number
Date of Structural Inspection	DD/MM/YYYY
Rotorcraft Flight Hours at Structural Inspection	Rotorcraft Flight Hours accumulated at Structural Inspection
Rotorcraft Landing at Structural Inspection	Rotorcraft Landing accumulated at Structural Inspection
Airport, where inspection was performed	Airport code (IATA)
MRBR (or AMPI Chapter 5) Task Reference	Reference to MRBR (or AMPI Chapter 5) Task initiating the inspection
Method of Inspection used	General visual inspection, detailed inspection, Non Destructive Testing



DESCRIPTION	COMMENT
Damages detected	Damage type (corrosion (level 1,2,3), crack, dent, ...)
Damage Location	Rotorcraft zone
Concerned Structure Part Description	According to Maintenance Documentation
FH since Last Inspection	Rotorcraft Flight Hours accumulated since last Structural Inspection
RL since Last Inspection	Rotorcraft Landing accumulated since last Structural Inspection
Calendar since Last Inspection	Rotorcraft Time accumulated since last Structural Inspection (DDDDDD)
Extent of Damage (mm, inches)	See.Structural Repair Manual to choose damage criteria
Damage Description	Text
Damage Cause	Text
Corrective Action/Repair	Text with reference to technical manual been used
Structural Inspection/Repair Labour Time	M/H
Structural Inspection/Repair Ground Time	HH:MM (Hours : Minutes)

Other data could be added by Operator / MRO organization in case deemed necessary.

Information must be provided to:

LEONARDO HELICOPTERS – Customer Support & Services Italy
Product Support Engineering Dept.
Via Indipendenza, 2 - 21018 Sesto Calende (VA) – Italy
Mail address: engineering.support.lhd@leonardo.com