

GSE & TOOL MANUAL

TITLE**P/N 3G6320G006951 AZIMUTH SENSOR INSTALLATION
TOOL**

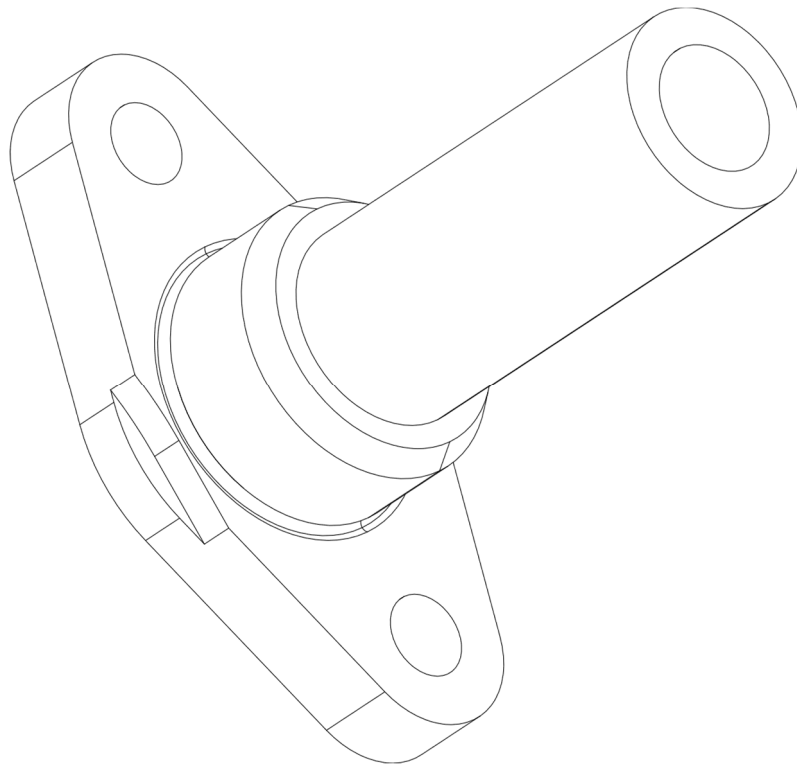

**GSE & TOOL
USE AND MAINTENANCE MANUAL**

Manual number:
**MAN-3G6320G006951
REV.A**

Pag. 2 of 18

REVISION HISTORY

REV	CHANGE DESCRIPTION	DATE
A	First issue	05/10/2023

SUMMARY

SUMMARY	3
LIST OF TABLE	4
LIST OF FIGURE	4
1. SCOPE	5
1.1. APPLICABILITY	5
1.2. OBJECT	5
1.3. WARNING and SAFETY INSTRUCTIONS.....	5
2. DOCUMENTS	6
2.1. APPLICABLE DOCUMENTS	6
2.2. ACRONYMS USED	6
3. DESCRIPTION	7
4. TOP ASSEMBLY DRAWINGS.....	7
5. IDENTIFICATION	7
6. OVERALL DIMENSIONS	8
7. WEIGHT	8
8. MAIN PARTS	9
9. MAIN FEATURES DESCRIPTION	9
10. WARNING AND SAFETY NOTES.....	10
10.1. WARNING NOTE.....	10
10.2. SAFETY NOTES.....	11
11. STORAGE.....	12
11.1. LUBRICATION BEFORE STORAGE	12
11.2. STORAGE CONFIGURATION	12
12. MAINTENANCE	12
12.1. CLEANING.....	12
12.1.1. SPECIAL TOOLS, FIXTURE AND EQUIPMENT.....	12
12.1.2. PART REQUIREMENTS	12
12.1.3. MANUAL CLEANING.....	13
12.2. CHECKS	13
12.2.1. SPECIAL TOOLS, FIXTURE AND EQUIPMENT.....	13
12.2.2. VISUAL EXAMINATION	14
12.2.3. PERIODICAL CHECKS	15
12.2.4. DIMENSIONAL CHECKS	15
12.2.5. SPECIAL CHECKS SUMMARY	15
13. CALIBRATION	15
14. SHELF LIFE	15

	GSE & TOOL USE AND MAINTENANCE MANUAL	Manual number: MAN-3G6320G006951 REV.A
		Pag. 4 of 18

15.	SPARE PARTS	16
15.1.	REPLACEMENT INSTRUCTIONS	16
16.	CE MARKING.....	16
17.	HAZARDOUS AND POTENTIALLY HAZARDOUS MATERIALS	17
	ANNEX A.....	18

LIST OF TABLE

Table 1 – Warning Instruction	5
Table 2 – Applicable Documents.....	6
Table 3 – Warning Note.....	10
Table 4 – Visual Check.....	14
Table 5 – Spare Parts.....	16

LIST OF FIGURE

<i>Figure 1 – Azimuth sensor installation tool rem/ins.....</i>	<i>7</i>
<i>Figure 2 – LHD Identification tag with P/N</i>	<i>7</i>
Figure 3 – Main Parts	9
<i>Figure 4 – Safety Notes.....</i>	<i>11</i>
Figure 5 – Spare Parts	16

1. SCOPE

1.1. APPLICABILITY

The contents of this document are meant to provide information on the P/N 3G6320G006951 AZIMUTH SENSOR INSTALLATION TOOL

1.2. OBJECT

The object of this document is to describe the AGE and its components, its main features and it will also provide all needed maintenance requirements to keep in service the P/N 3G6320G006951 AZIMUTH SENSOR INSTALLATION TOOL.

1.3. WARNING AND SAFETY INSTRUCTIONS

A number of symbols are used throughout this document to indicate information to which the user should pay attention to. These are indicated below along with the specific meaning.



 Warning	Indicates a potentially dangerous situation which might result in severe injuries or even death, if no precautions are taken.
 Caution	Indicates a potentially dangerous situation which might result damage to the equipment.
 Notice	Indicates an information that gives an advice to the operator.

Table 1 – Warning Instruction

2. DOCUMENTS

2.1. APPLICABLE DOCUMENTS

The following table lists the applicable documents

REF	REFERENCE OF DOCUMENT	TITLE
N.A.	39-A-31-32-16-00A-720A-K	Tachometer (MT34) - Install procedure.

Table 2 – Applicable Documents

2.2. ACRONYMS USED

The main acronyms used in this document are listed below:

LHD	Leonardo Helicopter Division
HC	Helicopter
P/N	Part Number
S/N	Serial Number
N.A.	Not Applicable

3. DESCRIPTION

This tool is used to measure the clearance between the prod of the tachometer (10) and the gear tip

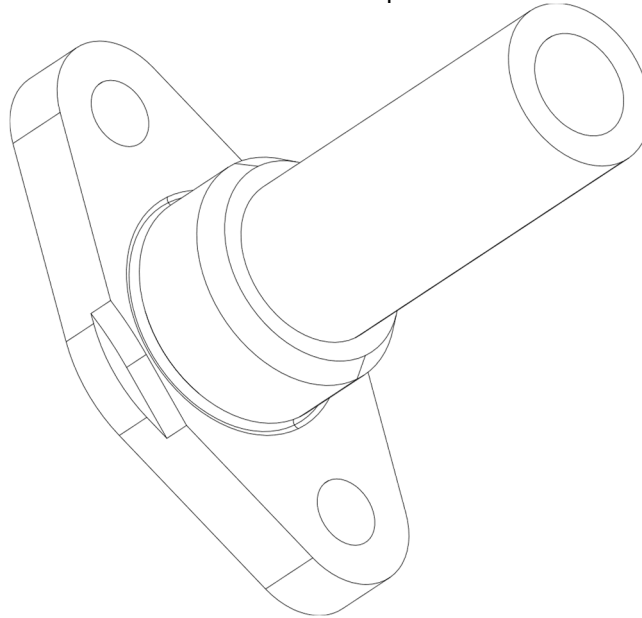

Figure 1 – Azimuth sensor installation tool rem/ins

4. TOP ASSEMBLY DRAWINGS

Refer to P/N 3G6320G006951 AZIMUTH SENSOR INSTALLATION TOOL.

5. IDENTIFICATION

The tool identification P/N is marked on the tool.

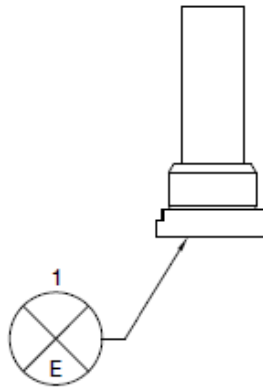

Figure 2 – P/N marking area



GSE & TOOL USE AND MAINTENANCE MANUAL

Manual number:
MAN-3G6320G006951
REV.A

Pag. 8 of 18

6. OVERALL DIMENSIONS

- Length: 60 mm
- Width: 55 mm
- Height: 30 mm

7. WEIGHT

- Total Weight: 0.072 kg

8. MAIN PARTS

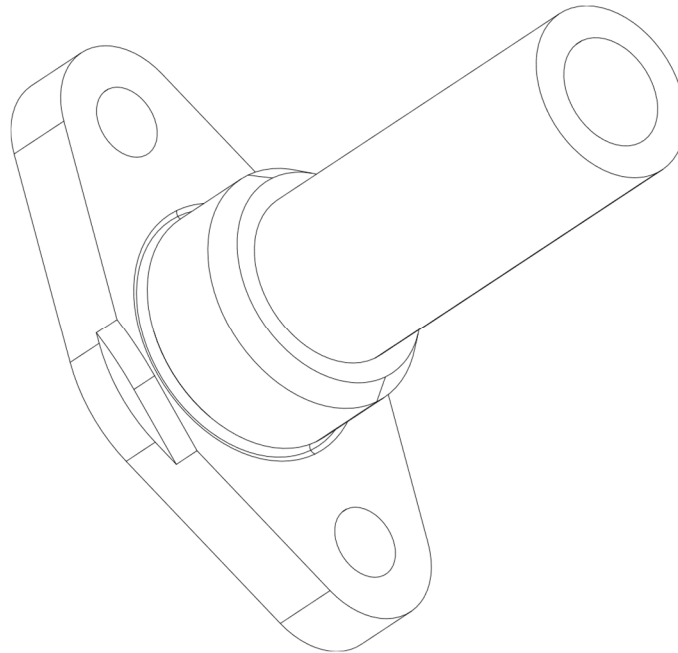

Figure 3 – Main Parts

The only part of the P/N 3G6320G006951 AZIMUTH SENSOR INSTALLATION TOOL is the installation tool

9. MAIN FEATURES DESCRIPTION

Installation tool

The tool is used to hold in place and allow the interface between the tip of the azimuth sensor and the external diameter of the toothed ring P/N 3G6320A0552x

10. WARNING AND SAFETY NOTES

10.1. WARNING NOTE





 Caution	Use this equipment only for the purpose that it is designed for. Any other use can result in injury or serious material damage to the components.
 Caution	The Manual can never integrally replace the adequate competence of the user.
 Caution	Before and after each use of the equipment is necessary to perform the checks required. Do not operate with a tool damaged or partially completed, or partially assembled.
 Caution	This Manual provides guidelines and instructions of the equipment that are in addition to - but are not intended to replace or modify but only to integrate - any general or specific rule, regulation, decree or law that is in force in the place where the equipment is in use.

Table 3 – Warning Note

10.2. SAFETY NOTES

Remember to wear protective overalls, safety shoes, protective gloves and glasses during all operational and maintenance phases.



Figure 4 – Safety Notes

	GSE & TOOL USE AND MAINTENANCE MANUAL	Manual number: MAN-3G6320G006951 REV.A
		Pag. 12 of 18

11. STORAGE

The Tool shall be properly stored to provide protection from external weather conditions, damage and dirty particles.

Ensure that the tool parts are clean before storage.

11.1. LUBRICATION BEFORE STORAGE

N.A.

11.2. STORAGE CONFIGURATION

The Tool has no particular storage configuration.

12. MAINTENANCE

 Notice	<p>Correct regular maintenance allows preventing most faults and safeguards of tool performance in time, thereby making it last longer.</p>
--	---

Every year carry out regular maintenance on a regular basis as detailed in this manual.

 Caution	<p>Inspection intervals for tool parts placed inside in ready storage is 12 months.</p>
---	---

12.1. CLEANING

Before inspection and after each use, carry out the cleaning of the tool components.

12.1.1. SPECIAL TOOLS, FIXTURE AND EQUIPMENT

No special tools, fixture and equipment are required for cleaning.

12.1.2. PART REQUIREMENTS

The parts to clean should be free from the moisture, emulsified water, soaps and metal shavings that can develop of corrosive acids.

They must also be free from wide grease and / or slush deposits.

12.1.3. MANUAL CLEANING

- A. Clean thoroughly all metal surfaces with a clean lint-free cloth (Local supply) moistened with Cleaning Solvent (MIL-PRF-680C, Type II) to do general spot cleaning of large groups areas.
- B. Repeat the cleaning process again by means another clean lint-free cloth (Local supply).
- C. Dry.
 - Verify that the solvent should not be trapped in the cavity. Normally, the solvent evaporates at room temperature in a satisfactory manner.



12.2. CHECKS

 Caution	Before and after each use or at least every year, carry out the check of kit component.
---	---

 Caution	Before each use ensure that the manual is available to the operator, in the event of loss, request a copy to Leonardo Helicopters Division.
---	---

The Tool kit shall be submitted to following checks to guarantee the functionality.

All required checks shall be registered on CHECK RECORDS Table (Ref. *TLC_Table 1*)

 Notice	After each use of tool ensure to have registered the number of uses on HISTORICAL USES RECORD Table (Ref. <i>TLC_Table 2</i>).
*  Notice	The Tool Log Card template contained in the Annex A of this manual can be replaced with any other log card template in use in the plant where the equipment is in use.

12.2.1. SPECIAL TOOLS, FIXTURE AND EQUIPMENT



No special tools, fixture and equipment are required for the checks.

12.2.2. VISUAL EXAMINATION

All required visual checks are listed on Table 4

PERIODICITY	CHECK TYPE	COMPONENTS	
BEFORE AND AFTER EVERY USE	VISUAL EXAMINATION	Evidence of impact	All
		Crushing or stripping	All
		Cracks	All
		Dents	All
		Wear	All
		Distortions	All
		Corrosion	All
		Loose or defective attaching parts (warning flag)	N.A.
		Unsticking of parts	N.A.
		Damage to the threads	N.A.
		Marking	All
		Damage to the pins and to the shell	N.A.
		Damage to the insulation sleeves and wires	N.A.

Table 4 – Visual Check

 Caution	Replace the parts that do not obey the inspection requirements.
 Notice	Restore the marking of the parts that results damaged or not readable.



GSE & TOOL USE AND MAINTENANCE MANUAL

Manual number:
MAN-3G6320G006951
REV.A

Pag. 15 of 18

12.2.3. PERIODICAL CHECKS

N.A.

12.2.4. DIMENSIONAL CHECKS

N.A.

12.2.5. SPECIAL CHECKS SUMMARY

N.A.

13. CALIBRATION

No Calibration is required.

14. SHELF LIFE

N.A.

15. SPARE PARTS

Any request of spare parts must indicate the reference number of the spares, the Part Number kit the Serial Number and Manufacturer Code of the assy for which the spare is requested.

Only standard fittings may be replaced with others with same dimensions, material, treatment surface and equal or higher strength.

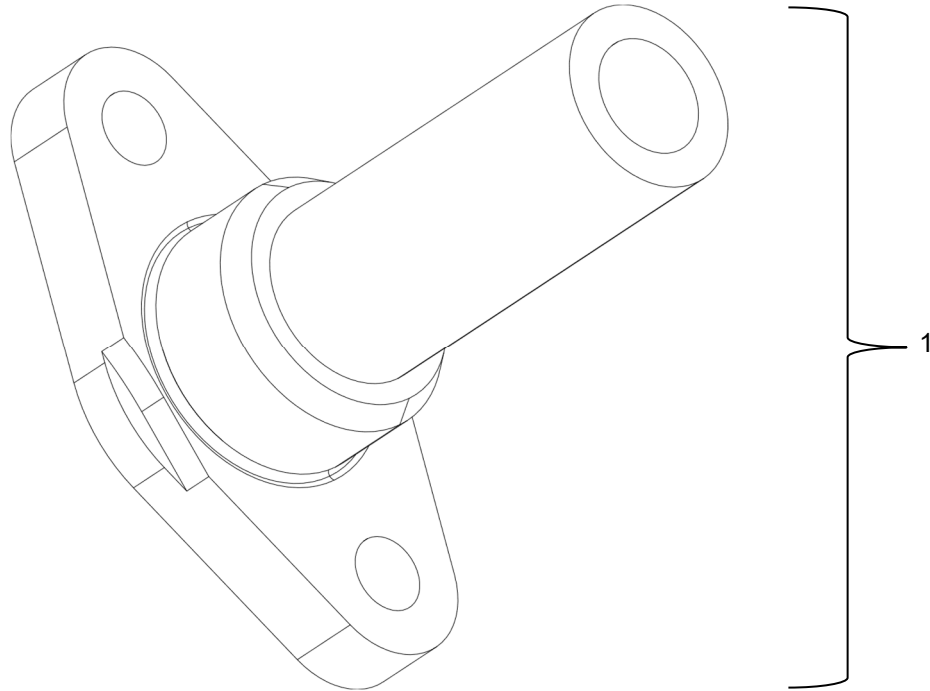

Figure 5 – Spare Parts

ITEM	P/N	DESCRIPTION	Q.TY	NOTE
1	3G6320G006951	AZIMUTH SENSOR INSTALLATION TOOL	REF	

Table 5 – Spare Parts



Notice

Note: For applicable replacement instructions Ref. Par. 15.1

15.1. REPLACEMENT INSTRUCTIONS

The replacement of parts does not require specific instructions.

16. CE MARKING

No CE marking is required for the P/N 3G6320G006951 AZIMUTH SENSOR INSTALLATION TOOL.

	GSE & TOOL USE AND MAINTENANCE MANUAL	Manual number: MAN-3G6320G006951 REV.A
		Pag. 17 of 18

17. HAZARDOUS AND POTENTIALLY HAZARDOUS MATERIALS

N.A.



GSE & TOOL
USE AND MAINTENANCE MANUAL

Manual number:
MAN-3G6320G006951
REV.A

Pag. 18 of 18

ANNEX A

TOOL LOG CARD

TOOL KIT P/N: [1]	TOOL KIT DESCRIPTION: [2]	TOOL KIT S/N: [3]
TOOL P/N: [4]	TOOL S/N: [5]	REMARKS: [6]

Section 1: CHECKS RECORD

[7] N° check	[8] DATE	[9] P/N TO CHECK	[10] CHECK	[11] FREQUENCY	[12] RESULT	[13] NOTE	[14] CERTIFICATION [15] STAMP & SIGNATURE
1							
2							
3							
4							
5							
6							
7							
8							
9							
10							
FINAL ACCEPTANCE [16]							
STAMP & SIGNATURE [17]							DATE [18]

TLC_Table 1

TOOL LOG CARD

TOOL KIT P/N: [1]	TOOL KIT DESCRIPTION: [2]	TOOL KIT S/N: [3]
TOOL P/N: [4]	TOOL S/N: [5]	REMARKS: [6]

Section 2: HISTORICAL USES RECORD

[19] N°USE	[8] DATE	[6] NOTE	[19] CERTIFICATION [13]		[6] NOTE	[13] CERTIFICATION [13]	
			[14] STAMP & SIGNATURE			[14] STAMP & SIGNATURE	
1							
2							
3							
4							
5							
6							
7							
8							
9							
10							
11							
12							
13							
14							
15							
16							
17							
18							
19							
20							

LOG CARD FILLING INSTRUCTIONS

FIELD #	HEADER	NOTE
1	Part number of the tool Kit	
2	Tool Kit denomination	
3	Serial Number of the tool Kit	
4	Part Number of the tool (part of kit)	
5	Serial Number of the tool (if applicable)	
6	Indicate any details of the use	
7	Sequential number of check performed	
8	Date of the activity	
9	PN of tool or component (part of tool) checked/affected by issue	
10	Typology or description of checks /issue	
11	Check frequency	
12	Check result	
13	Check remarks	
14	Performance certification	
15	Stamp and signature of the personnel which performs the check	
16	Section related to the final approval	
17	Stamp and signature of the personnel which performs the final approval	
18	Date on which the final check was made	
19	Sequential number of performed used of the tool	