



# GSE & TOOL USE AND MAINTENANCE MANUAL

Manual number:  
**MAN-3G1005G00431**  
**REV. A**

Pag. 1 of 17

## GSE & TOOL MANUAL

**TITLE**

**ENGINE EXHAUST AIR DUCT COVER LH/RH  
P/N 3G1005G00431**

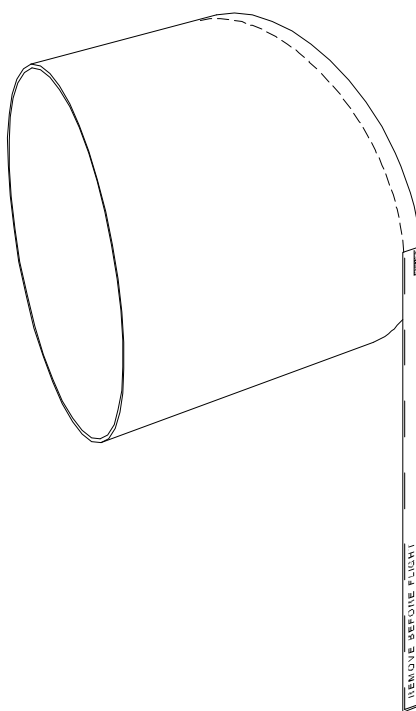

	<b>GSE &amp; TOOL USE AND MAINTENANCE MANUAL</b>	Manual number: <b>MAN-3G1005G00431</b> <b>REV. A</b>
		Pag. 2 of 17

## REVISION HISTORY

REV	CHANGE DESCRIPTION	DATE
A	First issue	26/11/2021

## SUMMARY

SUMMARY .....	3
LIST OF TABLE .....	4
LIST OF FIGURE .....	4
1. SCOPE .....	5
1.1. APPLICABILITY .....	5
1.2. OBJECT .....	5
1.3. WARNING AND SAFETY INSTRUCTIONS .....	5
2. DOCUMENTS .....	6
2.1. APPLICABLE DOCUMENTS .....	6
2.2. ACRONYMS USED .....	6
3. DESCRIPTION .....	7
4. TOP ASSEMBLY DRAWINGS .....	7
5. IDENTIFICATION .....	7
6. OVERALL DIMENSIONS .....	8
7. WEIGHT .....	8
8. MAIN PARTS .....	9
9. MAIN FEATURES DESCRIPTION .....	9
10. WARNING AND SAFETY NOTES .....	10
10.1. WARNING NOTE .....	10
10.2. SAFETY NOTES .....	11
11. STORAGE .....	12
11.1. LUBRICATION BEFORE STORAGE .....	12
11.2. STORAGE CONFIGURATION .....	12
12. MAINTENANCE .....	12
12.1. CLEANING .....	12
12.1.1. SPECIAL TOOLS, FIXTURE AND EQUIPMENT .....	12
12.1.2. PART REQUIREMENTS .....	12
12.1.3. MANUAL CLEANING .....	12
12.2. CHECKS .....	13
12.2.1. SPECIAL TOOLS, FIXTURE AND EQUIPMENT .....	13
12.2.2. VISUAL EXAMINATION .....	13
12.2.3. PERIODICAL CHECKS .....	14
12.2.4. DIMENSIONAL CHECKS .....	14
12.2.5. SPECIAL CHECKS SUMMARY .....	14
12.3. REPLACEMENT .....	14
12.3.1. REPLACEMENT PROCEDURES .....	14

	<b>GSE &amp; TOOL USE AND MAINTENANCE MANUAL</b>	Manual number: <b>MAN-3G1005G00431</b> <b>REV. A</b>
		Pag. 4 of 17

13.	CALIBRATION .....	14
14.	SHELF LIFE .....	14
15.	SPARE PARTS .....	15
16.	CE MARKING.....	16
	ANNEX A.....	17

### LIST OF TABLE

Table 1 – Warning Instruction .....	5
Table 2 – Applicable Documents.....	6
Table 3 – Warning Note.....	10
Table 4 – Visual Check.....	13
Table 5 – Spare Parts.....	15

### LIST OF FIGURE

<i>Figure 1 – Engine exhaust air duct cover LH/RH .....</i>	<i>7</i>
<i>Figure 2 – P/N marking area .....</i>	<i>7</i>
<i>Figure 3 – Main Parts .....</i>	<i>9</i>
<i>Figure 4 – Safety Notes.....</i>	<i>11</i>
<i>Figure 5 – Spare Parts .....</i>	<i>15</i>

## 1. SCOPE

### 1.1. APPLICABILITY



The contents of this document are meant to provide information on the P/N 3G1005G00431 ENGINE EXHAUST AIR DUCT COVER LH/RH.

### 1.2. OBJECT

The object of this document is to describe the AGE and its components, its main features and it will also provide all needed maintenance requirements to keep in service the P/N 3G1005G00431 ENGINE EXHAUST AIR DUCT COVER LH/RH.

### 1.3. WARNING AND SAFETY INSTRUCTIONS

A number of symbols are used throughout this document to indicate information to which the user should pay attention to. These are indicated below along with the specific meaning.

 <b>Warning</b>	...Indicates a danger that might arise from a product and might result in severe injuries or even death, if no precautions are taken.
 <b>Caution</b>	... Indicates a potentially dangerous situation, which might result injury or damage to the equipment.
 <b>Notice</b>	...Indicates a note providing information to help the reader during the procedure.

*Table 1 – Warning Instruction*

	<b>GSE &amp; TOOL USE AND MAINTENANCE MANUAL</b>	Manual number: <b>MAN-3G1005G00431</b> <b>REV. A</b>
		Pag. 6 of 17

## 2. DOCUMENTS

### 2.1. APPLICABLE DOCUMENTS

The following table lists the applicable documents

REF	REFERENCE OF DOCUMENT	TITLE
N.A.	N.A.	N.A.

*Table 2 – Applicable Documents*

### 2.2. ACRONYMS USED

The main acronyms used in this document are listed below:

LHD	Leonardo Helicopter Division
HC	Helicopter
P/N	Part Number
S/N	Serial Number
N.A.	Not Applicable
LH	Left Hand
RH	Right Hand

### 3. DESCRIPTION

This tool is used to cover the LH/RH engine exhaust air-ducts when the helicopter is moored in normal or abnormal conditions for short or long terms in extreme weather conditions and make sure that unwanted material and moisture does not enter the engine exhaust duct.

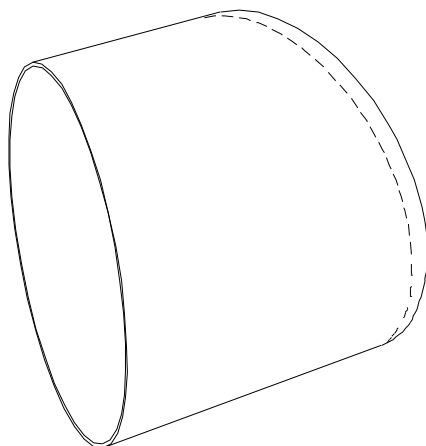

3G1005G00431\_1

*Figure 1 – Engine exhaust air duct cover LH/RH*

### 4. TOP ASSEMBLY DRAWINGS

Refer to P/N 3G1005G00431 ENGINE EXHAUST AIR DUCT COVER LH/RH.

### 5. IDENTIFICATION

The tool identification P/N is marked on the flag

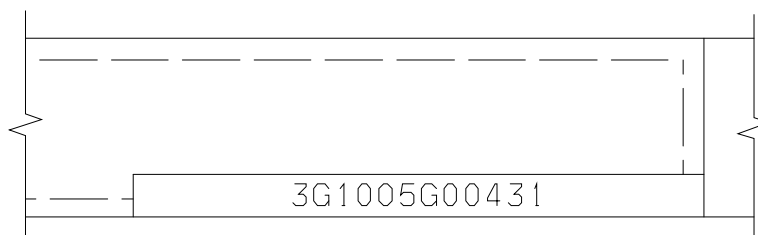

*Figure 2 – P/N marking area*



## GSE & TOOL USE AND MAINTENANCE MANUAL

Manual number:  
**MAN-3G1005G00431**  
**REV. A**

Pag. 8 of 17

### **6. OVERALL DIMENSIONS**

- Length: 530 mm
- Width: 200 mm
- Height: 380 mm

### **7. WEIGHT**

- Total Weight: Not available.



## 8. MAIN PARTS

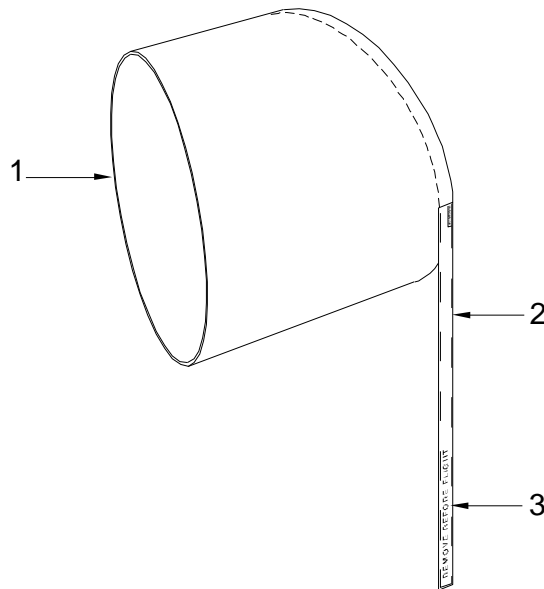

3G1005G00431\_2

*Figure 3 – Main Parts*

The main parts of the ENGINE EXHAUST AIR DUCT COVER LH/RH are:

1. Cover
2. Flag
3. Marking







## 9. MAIN FEATURES DESCRIPTION

The tool is composed of a fireproof and waterproof cover. The warning is applied on the tool:

- 1) REMOVE BEFORE FLIGHT, written on both sides of the flag.

## 10. WARNING AND SAFETY NOTES

### 10.1. WARNING NOTE

 <b>Warning</b>	<p>Use this equipment only for the purpose that it is designed for. Any other use can result in injury or serious material damage to the components.</p>
 <b>Caution</b>	
 <b>Notice</b>	<p>The Manual can never integrally replace the adequate competence of the user.</p>
 <b>Warning</b>	<p>Before and after each use of the equipment is necessary to perform the checks required. Do not operate with a tool damaged or partially completed, or partially assembled.</p>
 <b>Caution</b>	
 <b>Notice</b>	<p>This Manual provides guidelines and instructions of the equipment that are in addition to - but are not intended to replace or modify but only to integrate - any general or specific rule, regulation, decree or law that is in force in the place where the equipment is in use.</p>

*Table 3 – Warning Note*

## 10.2. SAFETY NOTES

Remember to wear protective overalls, safety shoes, protective gloves and glasses during all operational and maintenance phases.



*Figure 4 – Safety Notes*

## 11. STORAGE

The Tool shall be properly stored to provide protection from external weather conditions, damage and dirty particles.

Ensure that the tool parts are clean before storage.

### 11.1. LUBRICATION BEFORE STORAGE

N.A.

### 11.2. STORAGE CONFIGURATION

The tool has no particular storage configuration.

## 12. MAINTENANCE

NOTE: Correct regular maintenance allows preventing most faults and safeguards of tool performance in time, thereby making it last longer.

Every year carry out regular maintenance on a regular basis as detailed in this manual.

NOTE: Inspection intervals for tool parts placed inside in ready storage is 12 months.

### 12.1. CLEANING

Before inspection and after each use, carry out the cleaning of the tool components.

#### 12.1.1. SPECIAL TOOLS, FIXTURE AND EQUIPMENT

No special tools, fixture and equipment are required for cleaning.

#### 12.1.2. PART REQUIREMENTS

The parts to clean should be free from the moisture, emulsified water, soaps and metal shavings that can develop of corrosive acids.

They must also be free from wide grease and / or slush deposits.

#### 12.1.3. MANUAL CLEANING

- A. Clean the covers from sand or dust with a cotton cloth absolutely not wet.
- B. In the event of stain of oil and/or grease has to be used a cloth with neutral cleaner.
- C. Do not use solvents and/or cleaning products containing alcohol because it could damage the surface coating.

## 12.2. CHECKS

Before and after each use or at least every year, carry out the check of kit component.

Before each use ensure that the manual is available to the operator, in the event of loss, request a copy to Leonardo Helicopters Division.

The Tool kit shall be submitted to following checks to guarantee the functionality.

All required checks shall be registered on CHECK RECORDS Table. Ref. *TLC\_Table 1*

After each use of tool ensure to have registered the number of uses on HISTORICAL USES RECORD Table. Ref. *TLC\_Table 2*

The Tool Log Card template contained in the Annex A of this manual can be replaced with any other log card template in use in the plant where the equipment is in use.

### 12.2.1. SPECIAL TOOLS, FIXTURE AND EQUIPMENT

No special tools, fixture and equipment are required for the checks.

### 12.2.2. VISUAL EXAMINATION

NOTE: Replace the parts that do not obey the inspection requirements.

Restore the marking of the parts that results damaged or not readable.

All required visual checks are listed on Table 4

PERIODICITY	CHECK TYPE	COMPONENTS
BEFORE AND AFTER EVERY USE	Evidence of impact;	All
	Crushing or stripping	All
	Cracks	N.A.
	Dents	N.A.
	Wear	All
	Distortions	All
	Corrosion	N.A.
	Loose or defective attaching parts (warning flag)	All
	Unsticking of parts	N.A.
	Damage to the threads	N.A.
	Marking	All
	Damage to the pins and to the shell	N.A.
	Damage to the insulation sleeves and wires	N.A.

*Table 4 – Visual Check*



## GSE & TOOL USE AND MAINTENANCE MANUAL

Manual number:  
**MAN-3G1005G00431**  
**REV. A**

Pag. 14 of 17

### **12.2.3. PERIODICAL CHECKS**

Not Applicable.

### **12.2.4. DIMENSIONAL CHECKS**

Not Applicable.

### **12.2.5. SPECIAL CHECKS SUMMARY**

Not Applicable.

## **12.3. REPLACEMENT**

All the parts for which it is allowed the components replacement are listed in Paragraph 15.

### **12.3.1. REPLACEMENT PROCEDURES**

The replacement of parts of the kit does not require specific procedures.

## **13. CALIBRATION**

No Calibration is required.

## **14. SHELF LIFE**

Not Applicable.

## 15. SPARE PARTS

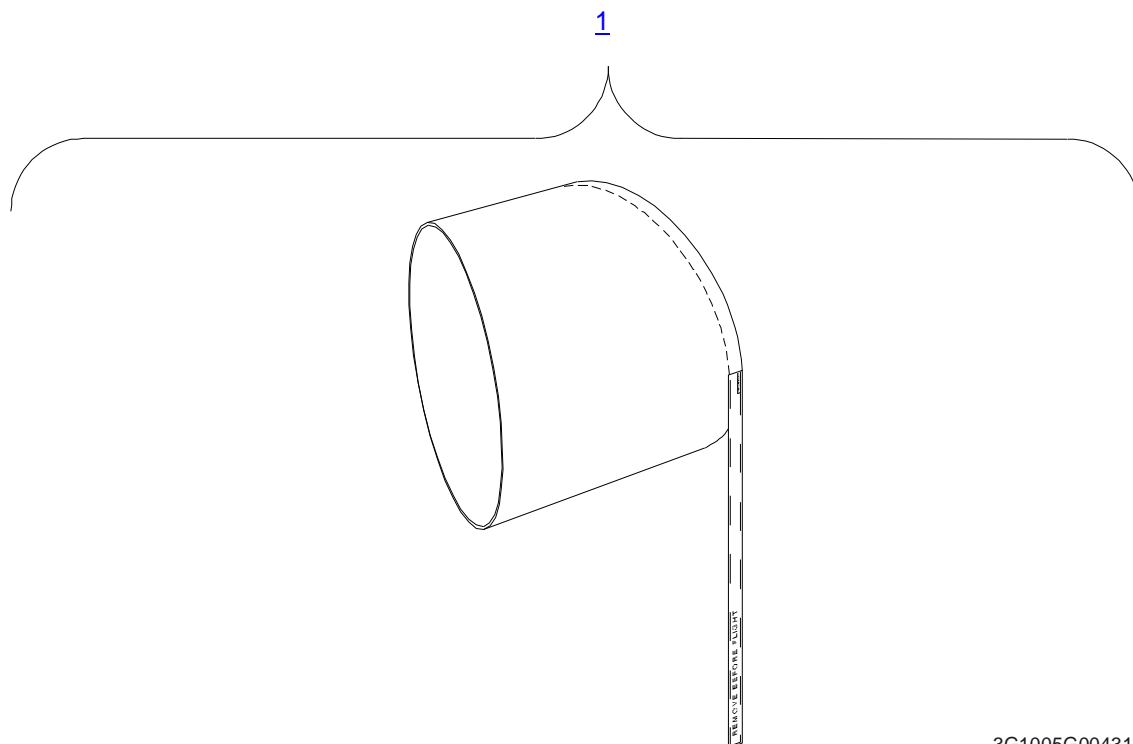

*Figure 5 – Spare Parts*

ITEM	P/N	DESCRIPTION	Q.TY
1	3G1005G00431	ENGINE EXHAUST AIR DUCT COVER LH/RH	REF

*Table 5 – Spare Parts*

	<b>GSE &amp; TOOL USE AND MAINTENANCE MANUAL</b>	Manual number: <b>MAN-3G1005G00431 REV. A</b> Pag. 16 of 17
---	--	---

## 16. CE MARKING

No CE marking is required for the P/N 3G1005G00431 ENGINE EXHAUST AIR DUCT COVER LH/RH.





GSE & TOOL  
USE AND MAINTENANCE MANUAL

Manual number:  
**MAN-3G1005G00431**  
**REV. A**

Pag. 17 of 17

# ANNEX A

# TOOL LOG CARD



# TOOL LOG CARD

ISSUE -/  
Pag. 1 of 3

<b>TOOL KIT P/N:</b> [1]	<b>TOOL KIT DESCRIPTION:</b> [2]	<b>TOOL KIT S/N:</b> [3]
<b>TOOL P/N:</b> [4]	<b>TOOL S/N:</b> [5]	<b>REMARKS:</b> [6]

## Section 1: CHECKS RECORD

[7] N° check	[8] DATE	[9] P/N TO CHECK	[10] CHECK	[11] FREQUENCY	[12] RESULT	[13] NOTE	CERTIFICATION [14]
							STAMP & SIGNATURE [15]
1							
2							
3							
4							
5							
6							
7							
8							
9							
10							
<b>FINAL ACCEPTANCE [16]</b>							
<b>STAMP &amp; SIGNATURE [17]</b>						<b>DATE [18]</b>	

TLC\_Table 1



# TOOL LOG CARD

ISSUE -/-  
Pag. 2 of 3

<b>TOOL KIT P/N:</b> [1]	<b>TOOL KIT DESCRIPTION:</b> [2]	<b>TOOL KIT S/N:</b> [3]
<b>TOOL P/N:</b> [4]	<b>TOOL S/N:</b> [5]	<b>REMARKS:</b> [6]

## Section 2: HISTORICAL USES RECORD

[19] N°USE	[8] DATE	[6] NOTE	[13] CERTIFICATION	[19] N°USE	[8] DATE	[6] NOTE	[13] CERTIFICATION
			[14] STAMP & SIGNATURE				[14] STAMP & SIGNATURE
1				11			
2				12			
3				13			
4				14			
5				15			
6				16			
7				17			
8				18			
9				19			
10				20			

TLC\_Table 2

## LOG CARD FILLING INSTRUCTIONS

<b>FIELD #</b>	<b>HEADER</b>	<b>NOTE</b>
<b>1</b>	Part number of the tool Kit	
<b>2</b>	Tool Kit denomination	
<b>3</b>	Serial Number of the tool Kit	
<b>4</b>	Part Number of the tool (part of kit)	
<b>5</b>	Serial Number of the tool (if applicable)	
<b>6</b>	Indicate any details of the use	
<b>7</b>	Sequential number of check performed	
<b>8</b>	Date of the activity	
<b>9</b>	PN of tool or component (part of tool) checked/affected by issue	
<b>10</b>	Typology or description of checks /issue	
<b>11</b>	Check frequency	
<b>12</b>	Check result	
<b>13</b>	Check remarks	
<b>14</b>	Performance certification	
<b>15</b>	Stamp and signature of the personnel which performs the check	
<b>16</b>	Section related to the final approval	
<b>17</b>	Stamp and signature of the personnel which performs the final approval	
<b>18</b>	Date on which the final check was made	
<b>19</b>	Sequential number of performed used of the tool	