

PRATT & WHITNEY CANADA
SERVICE BULLETIN

P&WC S.B. No. 28404

BULLETIN INDEX LOCATOR
72-51-04

TURBOSHAFT ENGINE
NOZZLE-ASSEMBLY TURBINE EXHAUST - REPLACEMENT OF

MODEL APPLICATION

PW206A, PW206B, PW206B2, PW206B3, PW206C, PW206E, PW207C, PW207D, PW207D1,
PW207D2, PW207E, PW207K

Compliance: CATEGORY 7

Summary: Brazing gaps between No. 5 cover bearing housing and oil tubes are not in line with the engineering specification. Replace No. 5 cover bearing housing with a new one that has increased holes diameter to meet brazing specification requirements.

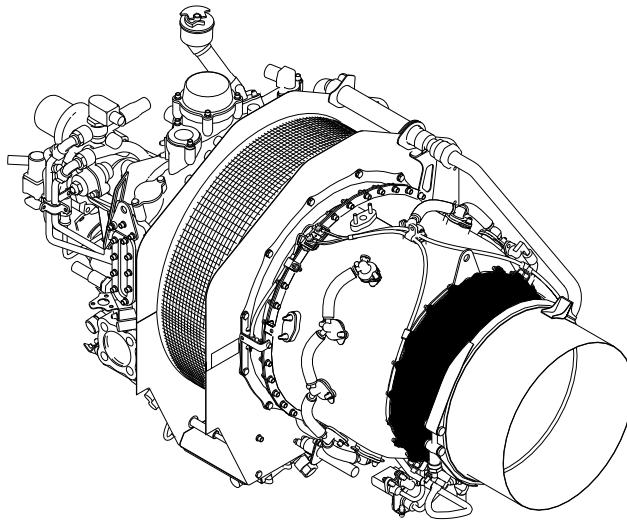

Mar 11/2023

PW200-72-28404
Cover Sheet

24-Hour Global Service

CFIRST CENTRE

Toll free where available (SIL GEN-027)

USA & CANADA..... 1-800-268-8000

International (IAC*)+8000-268-8000

* International Access Code

Other 1-450-647-8000

Fax 1-450-647-2888

Web Site www.pwc.ca

WARNING - PROPRIETARY RIGHTS & EXPORT CONTROLS NOTICE

This bulletin contains proprietary information of Pratt & Whitney Canada Corp. ("P&WC"), which P&WC provides in confidence and solely for the purposes of supporting engine certification and providing applicable information regarding the proper use, maintenance, inspection, repair, servicing and parts application of P&WC products and services, as directed therein. Neither this bulletin nor any information in it may be disclosed to others, or used for any other purpose, including, without limitation, to design, create, develop, reproduce, manufacture or derive any design, part, product, material, process, modification, configuration change or repair, or obtain FAA or other government approval to do so. Possession and use of this bulletin is also subject to the restrictions set out in P&WC's Technical Data Agreement (a copy of which may be obtained by contacting P&WC Technical Publications). The contents of this bulletin may be subject to export control laws. Unauthorized export or re-export of the bulletin, or parts thereof, is prohibited. By accepting and possessing this bulletin, you agree to be bound by the foregoing terms.

If a Government agency or department intends to disclose any information, written notice should be given to:

VP - Legal Services, Pratt & Whitney Canada Corp., 1000 Marie-Victorin (01BE5), Longueuil, Quebec J4G 1A1.

PRATT & WHITNEY CANADA

SERVICE BULLETIN

P&WC S.B. No. 28404

TURBOSHAFT ENGINE NOZZLE-ASSEMBLY TURBINE EXHAUST - REPLACEMENT OF

1. Planning Information

A. Effectivity

PW206A (BS752) Engines.

PW206B (BS778) Engines.

PW206B2 (BS1028, BS1170) Engines which are before and include Serial No. PCE-BJ1487.

PW206B3 (BS1028, BS1170) Engines which are before and include Serial No. PCE-BR0227.

PW206C (BS847, BS1164, BS1296, BS1297) Engines which are before and include Serial No. PCE-BC1019, and Serial Numbers 208001 to 208999.

PW206E (BS934) Engines which are before and include Serial No. PCE-BE0052.

PW207C (BS1068, BS1166, BS1299, BS1300) Engines which are before and include Serial No. PCE-BH1095.

PW207D (BS993, BS1167) Engines which are before and include Serial No. PCE-BF0215.

PW207D1 (BS1215) Engines which are before and include Serial No. PCE-BL1033.

PW207D2 (BS1247, BS1281) Engines which are before and include Serial No. PCE-BN0030.

PW207E (BS1035, BS1168) Engines which are before and include Serial No. PCE-BG0193.

PW207K (BS1031, BS1169, BS1301, BS1302) Engines which are before and include Serial No. PCE-BK0386.

NOTE: The above effectivity list does not identify engines that have been converted from one engine model to another via an engine conversion service bulletin. To clarify the effectivity of converted engines, refer to the original engine effectivity above. For the parts embodied during the engine conversion, refer to conversion service bulletin.

B. Concurrent Requirements

None.

C. Reason

(1) Problem

Brazing clearances between No. 5 cover bearing housing and oil tubes are not optimal.

(2) Cause

Brazing clearances are not in line with engineering specification.

(3) Solution

Replace No. 5 cover bearing housing with a new one that has increased holes diameter to meet brazing specification requirements.

P&WC No. CO-0012335

Mar 11/2023

P&WC Proprietary Information. Subject to the restrictions on the back of the locator

© 2023 Pratt & Whitney Canada Corp.
PRINTED IN CANADA

PW200-72-28404
Page 1 of 7

PRATT & WHITNEY CANADA
SERVICE BULLETIN

P&WC S.B. No. 28404

TURBOSHAFT ENGINE
NOZZLE-ASSEMBLY TURBINE EXHAUST - REPLACEMENT OF

1. Planning Information (Cont'd)

D. Description

Replace the Turbine Exhaust Nozzle-Assembly with a new one.

E. Compliance

CATEGORY 7 - You can do this service bulletin when the supply of superseded parts is fully used.

F. Approval

The technical content of this document is approved under the authority of the Transport Canada Civil Aviation (TCCA) Design Approval Organization No: DAO #93-Q-01.

G. Manpower

No more man-hours is required to include this service bulletin at Heavy Maintenance.

No more man-hours are necessary to include this service bulletin at overhaul.

H. Weight and Balance

None.

I. Electrical Load Data

Not applicable.

J. Software Accomplishment Summary

Not applicable.

K. References

Illustrated Parts Catalog P/N [3038326](#) (PW206A/206E)

Illustrated Parts Catalog P/N [3049725](#) (PW207E)

Illustrated Parts Catalog P/N [3039734](#) (PW206B)

Illustrated Parts Catalog P/N [3054928](#) (PW206B2/206B3)

Illustrated Parts Catalog P/N [3043324](#) (PW206C)

PRATT & WHITNEY CANADA SERVICE BULLETIN

P&WC S.B. No. 28404

TURBOSHAFT ENGINE NOZZLE-ASSEMBLY TURBINE EXHAUST - REPLACEMENT OF

1. Planning Information (Cont'd)

- Illustrated Parts Catalog P/N [3054927](#) (PW207C)
- Illustrated Parts Catalog P/N [3049724](#) (PW207D)
- Illustrated Parts Catalog P/N [3071604](#) (PW207D1/207D2)
- Illustrated Parts Catalog P/N [3053374](#) (PW207K)
- Maintenance Manual P/N [3038324](#) (PW206A/206E/207E)
- Maintenance Manual P/N [3039732](#) (PW206B/206B2/206B3)
- Maintenance Manual P/N [3043322](#) (PW206C/207C)
- Maintenance Manual P/N [3043612](#) (PW207D)
- Maintenance Manual P/N [3071602](#) (PW207D1/207D2)
- Maintenance Manual P/N [3053372](#) (PW207K)
- Overhaul Manual P/N [3038325](#) (PW206A/206E/207E)
- Overhaul Manual P/N [3039733](#) (PW206B/206B2/206B3)
- Overhaul Manual P/N [3043323](#) (PW206C/207C)
- Overhaul Manual P/N [3043613](#) (PW207D)
- Overhaul Manual P/N [3071603](#) (PW207D1/207D2)
- Overhaul Manual P/N [3053373](#) (PW207K)

L. Publications Affected

- Illustrated Parts Catalog P/N [3038326](#) (PW206A/206E)
- Illustrated Parts Catalog P/N [3049725](#) (PW207E)
- Illustrated Parts Catalog P/N [3039734](#) (PW206B)
- Illustrated Parts Catalog P/N [3054928](#) (PW206B2/206B3)
- Illustrated Parts Catalog P/N [3043324](#) (PW206C)
- Illustrated Parts Catalog P/N [3054927](#) (PW207C)

PRATT & WHITNEY CANADA SERVICE BULLETIN

P&WC S.B. No. 28404

TURBOSHAFT ENGINE NOZZLE-ASSEMBLY TURBINE EXHAUST - REPLACEMENT OF

1. Planning Information (Cont'd)

Illustrated Parts Catalog P/N [3049724](#) (PW207D)

Illustrated Parts Catalog P/N [3071604](#) (PW207D1/207D2)

Illustrated Parts Catalog P/N [3077164](#) (PW207D2M)

Illustrated Parts Catalog P/N [3053374](#) (PW207K)

Cleaning Inspection Repair Manual (CIR) P/N [3040877](#)

M. Interchangeability and Intermixability of Parts

Interchangeability - Refer to Para. 2.C.

Intermixability - Not changed.

2. Material Information

A. Industry Support Information

Not applicable.

B. Material - Price and Availability

You can get the procurable parts listed in Para. 2.C. from any Pratt & Whitney Canada Parts Distribution Center.

The estimated total cost of new parts needed to replace old parts is Quote (US, 2023).

The new parts are available.

C. Material Necessary for Each Engine

The quantity of materials listed in this section is on a per engine basis.

<u>New P/N</u>	<u>Keyword</u>	<u>Old P/N</u>	<u>Qty</u>	<u>Est. Unit List Price (\$US, 2023)</u>	<u>Instructions Dispositions</u>
3137075	Nozzle Assembly, Turbine Exhaust	3077647-01	1	Quote	(A)(B)

(A) TWO WAY INTERCHANGEABLE (ATA 200 Explanation Code 02): The old or the new parts can replace the old or the new part.

(B) Discard the part if it is unserviceable. Return a serviceable part to stock.

Mar 11/2023

P&WC Proprietary Information. Subject to the restrictions on the back of the locator

PW200-72-28404
Page 4 of 7

PRATT & WHITNEY CANADA

SERVICE BULLETIN

P&WC S.B. No. 28404

TURBOSHAFT ENGINE

NOZZLE-ASSEMBLY TURBINE EXHAUST - REPLACEMENT OF

2. Material Information (Cont'd)

D. Reidentified Parts

None.

E. Tooling - Price and Availability

Not Applicable

3. Accomplishment Instructions

A. Remove the parts in the Old P/N list in Para. 2.C., Material Information, in accordance with the maintenance or overhaul manual instructions as follows:

For Engines PW206A, PW206E:

- Ref. MM 72-00-30 HSI (PW206A/PW206E) - HEAVY MAINTENANCE.
- Ref. OHM 72-51-04 EXHAUST SECTION - DISASSEMBLY.

For Engines PW206B:

- Ref. MM 72-00-30 HSI (PW206B (PRE-SB28187)) - HEAVY MAINTENANCE.
- Ref. OHM 72-51-04 EXHAUST SECTION - DISASSEMBLY.

For Engines PW206B2, PW206B3:

- Ref. MM 72-00-31 HSI (PW206B (Post-SB28187), PW206B2 AND PW206B3)- HEAVY MAINTENANCE.
- Ref. OHM 72-51-04 EXHAUST SECTION - DISASSEMBLY.

For Engines PW206C, PW207C:

- Ref. MM 72-00-30 HSI (PW206C (PRE-SB28187)) - HEAVY MAINTENANCE.
- Ref. MM 72-00-31 HSI (PW206C (Post-SB28187), PW207C) - HEAVY MAINTENANCE.
- Ref. OHM 72-51-04 EXHAUST SECTION - DISASSEMBLY.

For Engines PW207D, PW207D1, PW207D2, PW207K:

- Ref. MM 72-00-30 HSI - HEAVY MAINTENANCE.
- Ref. OHM 72-51-04 EXHAUST SECTION - DISASSEMBLY.

For Engines PW207E:

- Ref. MM 72-00-31 HSI (PW207E) - HEAVY MAINTENANCE.
- Ref. OHM 72-51-04 EXHAUST SECTION - DISASSEMBLY.

B. Install the parts in the New P/N list in Para. 2.C., Material Information, in accordance with the maintenance or overhaul manual instructions as follows:

For Engines PW206A, PW206E:

- Ref. MM 72-00-30 HSI (PW206A/PW206E) - HEAVY MAINTENANCE.
- Ref. OHM 72-51-04 EXHAUST SECTION - SUBASSEMBLY.

For Engines PW206B:

PRATT & WHITNEY CANADA

SERVICE BULLETIN

P&WC S.B. No. 28404

TURBOSHAFT ENGINE NOZZLE-ASSEMBLY TURBINE EXHAUST - REPLACEMENT OF

3. Accomplishment Instructions (Cont'd)

- Ref. MM 72-00-30 HSI (PW206B (PRE-SB28187)) - HEAVY MAINTENANCE.
- Ref. OHM 72-51-04 EXHAUST SECTION - SUBASSEMBLY.
- For Engines PW206B2, PW206B3:**
- Ref. MM 72-00-31 HSI (PW206B (Post-SB28187), PW206B2 AND PW206B3)- HEAVY MAINTENANCE.
- Ref. OHM 72-51-04 EXHAUST SECTION - SUBASSEMBLY.
- For Engines PW206C, PW207C:**
- Ref. MM 72-00-30 HSI (PW206C (PRE-SB28187)) - HEAVY MAINTENANCE.
- Ref. MM 72-00-31 HSI (PW206C (Post-SB28187), PW207C) - HEAVY MAINTENANCE.
- Ref. OHM 72-51-04 EXHAUST SECTION - SUBASSEMBLY.
- For Engines PW207D, PW207D1, PW207D2, PW207K:**
- Ref. MM 72-00-30 HSI - HEAVY MAINTENANCE.
- Ref. OHM 72-51-04 EXHAUST SECTION - SUBASSEMBLY.
- For Engines PW207E:**
- Ref. MM 72-00-31 HSI (PW207E) - HEAVY MAINTENANCE.
- Ref. OHM 72-51-04 EXHAUST SECTION - SUBASSEMBLY.

C. Write the accomplishment of P&WC SB28404 in the engine module log book.

4. Appendix

Refer to Table 1 Sheet 1and Figure 1 for Fits and Clearances.

TABLE 1, Fits and Clearances

REF. NO.	IFR	Name	Dim. for Ref. inches (mm)		Limits inches (mm)		Replace
			Min.	Max.	Min.	Max	
PRE-SB		Tube Oil No. 5 Brg.	0.4260 (10.820)	0.4275 (10.859)	0.0005 (0.013)	0.0040 (0.102)	
		Cover No. 5 Brg. Hsg.	0.4280 (10.871)	0.4300 (10.922)			
POST-SB		Tube Oil No. 5 Brg.	0.4260 (10.820)	0.4275 (10.859)	0.0025 (0.064)	0.0060 (0.152)	
		Cover No. 5 Brg. Hsg.	0.4300 (10.922)	0.4320 (10.973)			

PRATT & WHITNEY CANADA SERVICE BULLETIN

P&WC S.B. No. 28404

TURBOSHAFT ENGINE NOZZLE-ASSEMBLY TURBINE EXHAUST - REPLACEMENT OF

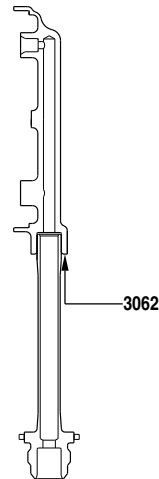
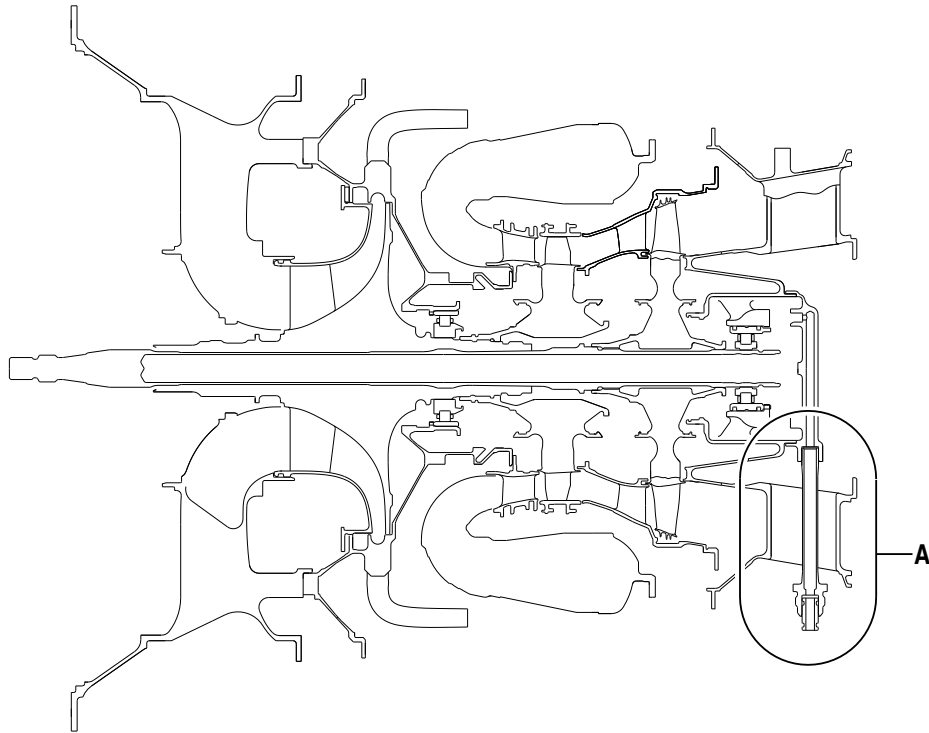

VIEW A

ICN-00198-G000125481-001-01

Fits and Clearances
Figure 1

Mar 11/2023

P&WC Proprietary Information. Subject to the restrictions on the back of the locator

PW200-72-28404
Page 7 of 7