



LEONARDO MALAYSIA SDN.BHD.

WORK CARD

SERVICE ORDER NUMBER:

90025566

WORKCARD NUMBER:

2023/BGH/001-07

TITLE:

SB 139-665 DATE: JULY 8, 2021 REV. : A - MAY 31, 2022 -
ATA 34 - ENHANCED GROUND PROXIMITY WARNING
SYSTEM INSTALLATION (PART II)

CUSTOMER:

LEONARDO HELICOPTER ITALY (LHI)

REGISTRATION:	9M-BGH	AIRFRAME HOURS:	302:40	#1 ENGINE	SERIAL NUMBER:	PCE-KB1931	#2 ENGINE	SERIAL NUMBER:	PCE-KB1885	APU	SERIAL NUMBER:	N/A
SERIAL NUMBER:	31763	LANDINGS:	850		HOURS:	302:40		HOURS:	302:40		HOURS:	N/A

NO	SOURCE	TASK / REFERENCE	REMARKS	MECHANIC SIGN	* AH SIGN & STAMP	DATE
----	--------	------------------	---------	---------------	-------------------	------

NOTE: FOR FIGURE(S), REFER TO IETP / ENGINE MANUAL / AD / SB.

ACCOMPLISHMENT INSTRUCTIONS

GENERAL NOTES

- A) PLACE AN IDENTIFICATION TAG ON ALL COMPONENTS THAT ARE RE-USABLE, INCLUDING THE ATTACHING HARDWARE THAT HAS BEEN REMOVED TO GAIN ACCESS TO THE MODIFICATION AREA AND ADEQUATELY PROTECT THEM UNTIL THEIR LATER REUSE.
- B) SHAPE THE CABLES IN ORDER TO PREVENT INTERFERENCE WITH THE STRUCTURE AND THE OTHER EXISTING INSTALLATIONS, USING WHERE NECESSARY SUITABLE LACING CORDS AND PLASTIC CABLE TIEDOWN.
- C) EXERCISE EXTREME CARE DURING DRILLING OPERATIONS TO PREVENT INSTRUMENTS, CABLES AND HOSES DAMAGE.
- D) AFTER DRILLING, REMOVE ALL SWARF AND SHARP EDGES. APPLY ON BARE METAL A LIGHT FILM OF PRIMER UNLESS THE HOLE IS USED FOR GROUND CONNECTION.
- E) DURING THE INSTALLATION OF BONDING BRAIDS OR COMPONENTS REQUIRING GROUNDING, CLEAN THE SURFACE STRUCTURE IN ORDER TO OBTAIN A GOOD GROUND CONTACT.
- F) LET ADHESIVE CURE AT ROOM TEMPERATURE FOR AT LEAST 24 HOURS UNLESS OTHERWISE SPECIFIED.
- G) ALL LENGTHS ARE IN MM.

PARTS / MATERIAL USED / COMPONENT CHANGE RECORD HAVE BEEN RAISED AND ATTACHED.

CALIBRATED / SPECIAL TOOLS RECORD SHEET HAVE BEEN RAISED AND ATTACHED.



















* APPROVAL HOLDER HAVE VERIFIED THAT ALL TOOLS, EQUIPMENT AND OTHER EXTRANEIOUS PART OF MATERIALS ARE CLEARED AND ALL TASKS OR INSPECTIONS HAVE BEEN CARRIED OUT TO THE REQUIRED STANDARD. TASK HAS BEEN PERFORMED I.A.W MAINTENANCE MANUAL SPECIFIED IN WORKPACK INDEX LM/QA/GEN/01.

NO	SOURCE	TASK / REFERENCE	REMARKS	MECHANIC SIGN	* AH SIGN & STAMP	DATE
1	-	IN ACCORDANCE WITH DM 39-A-00-20-00-00A-120A-A, PREPARE THE HELICOPTER ON GROUND FOR A SAFE MAINTENANCE. DISCONNECT THE BATTERY, ALL ELECTRICAL POWER SOURCES AND/OR THE EXTERNAL POWER SUPPLY.	SATISFACTORY DISCONNECTED	<i>[Signature]</i>	<i>[Signature]</i> LOG LM	14/2/23
2	-	IN ACCORDANCE WITH DM 39-A-06-41-00-00A-010A-A AND WITH REFERENCE TO FIGURES 17 THRU 31, REMOVE ALL EXTERNAL PANELS, INTERNAL PANELS AND INTERNAL LINERS AS REQUIRED TO GAIN ACCESS TO THE AREA AFFECTED BY THE INSTALLATION AND PERFORM EGPWS COMPLETE PROVISION P/N 4G3440A00113 AS DESCRIBED IN THE FOLLOWING PROCEDURE: 2.1 WITH REFERENCE TO FIGURE 17 AND FIGURE 18, PERFORM EGPWS STRUCTURAL PROVISION P/N 3G5310A04513 AS DESCRIBED IN THE FOLLOWING PROCEDURE: 2.1.1 WITH REFERENCE TO FIGURE 17 VIEW B AND DETAIL C, TEMPORARILY LOCATE THE RH SUPPORT ASSY P/N 3G5315A28131, THE LH SUPPORT ASSY P/N 3G5315A28031, THE RH JOINT P/N 3G5315A28551 AND THE LH JOINT P/N 3G5315A28451 ON THE LOWER FRAME STA 7200 P/N 3P5340A10453 AND COUNTERMARK N°48 RIVET HOLES POSITIONS. 2.1.2 WITH REFERENCE TO FIGURE 17 VIEW B AND DETAIL C, DRILL N°48 RIVET HOLES IN THE PREVIOUSLY MARKED POSITIONS THRU THE LOWER FRAME STA 7200 P/N 3P5340A10453. PREPARE THE SURFACE TO ASSURE A GOOD GROUND CONTACT.	SATISFACTORY REMOVED PANELS AND LINERS. SATISFACTORY LOCATED SUPPORT. COUNTERMARK PERFORMED SATISFACTORY.	<i>[Signature]</i>	<i>[Signature]</i> LOG T01	14/2/23
			SATISFACTORY DRILLED	<i>[Signature]</i>	<i>[Signature]</i> LOG LM	14/2/23













PARTS / MATERIAL USED / COMPONENT CHANGE RECORD HAVE BEEN RAISED AND ATTACHED.

CALIBRATED / SPECIAL TOOLS RECORD SHEET HAVE BEEN RAISED AND ATTACHED.

* APPROVAL HOLDER HAVE VERIFIED THAT ALL TOOLS, EQUIPMENT AND OTHER EXTRANEIOUS PART OF MATERIALS ARE CLEARED AND ALL TASKS OR INSPECTIONS HAVE BEEN CARRIED OUT TO THE REQUIRED STANDARD. TASK HAS BEEN PERFORMED I.A.W MAINTENANCE MANUAL SPECIFIED IN WORKPACK INDEX LM/QA/GEN/01.

NO	SOURCE	TASK / REFERENCE	REMARKS	MECHANIC SIGN	* AH SIGN & STAMP	DATE
		2.1.3 WITH REFERENCE TO FIGURE 17 DETAIL C, REMOVE THE EXISTING RIVETS FROM THE ANGLE STA 7200 P/N 3P5340A13152 AND INSTALL THE RIVETS P/N NAS1097AD4-5.	SATISFACTORY REMOVED.		 	14/2/23
		2.1.4 WITH REFERENCE TO FIGURE 17 VIEW B AND DETAIL C, INSTALL THE RH SUPPORT ASSY P/N 3G5315A28131, THE LH SUPPORT ASSY P/N 3G5315A28031, THE RH JOINT P/N 3G5315A28551 AND THE LH JOINT P/N 3G5315A28451 ON THE LOWER FRAME STA 7200 P/N 3P5340A10453 BY MEANS OF N°48 RIVETS P/N AGS4719-508.	SATISFACTORY EACH PANEL INSTALLED		 	14/2/23
		2.1.5 WITH REFERENCE TO FIGURE 17 VIEW D-D, DRILL N°1 HOLE THRU THE LH JOINT P/N 3G5315A28451 AND LH SUPPORT ASSY P/N 3G5315A28031 AND N°1 HOLE THRU THE RH JOINT P/N 3G5315A28551 RH SUPPORT ASSY P/N 3G5315A28131 IN ACCORDANCE WITH THE DIMENSIONING SHOWN.	SATISFACTORY DRILLED.		 	14/2/23
		2.1.6 WITH REFERENCE TO FIGURE 17 VIEW D-D, FIX THE RH JOINT P/N 3G5315A28551 TO THE RH SUPPORT ASSY P/N 3G5315A28131, AND THE LH JOINT P/N 3G5315A28451 TO THE LH SUPPORT ASSY P/N 3G5315A28031, BY MEANS OF N°2 RIVETS P/N AGS4719-407.	SATISFACTORY FIXED.		 	14/2/23
		2.1.7 WITH REFERENCE TO FIGURE 17 VIEW E, TEMPORARILY LOCATE THE PANEL P/N 3G5315A29151 ON THE RH SUPPORT ASSY P/N 3G5315A28131 AND THE LH SUPPORT ASSY P/N 3G5315A28031 AND COUNTERMARK N°8 RIVET HOLES POSITIONS.	SATISFACTORY LOCATED AND COUNTERMARKED.		 	14/2/23
		2.1.8 WITH REFERENCE TO FIGURE 17 VIEW E, DRILL N°8 RIVET HOLES IN THE PREVIOUSLY MARKED POSITIONS THRU THE RH SUPPORT ASSY P/N 3G5315A28131 AND THE LH	SATISFACTORY DRILLED.		 	14/2/23







<input type="checkbox"/> PARTS / MATERIAL USED / COMPONENT CHANGE RECORD HAVE BEEN RAISED AND ATTACHED.	<input type="checkbox"/> CALIBRATED / SPECIAL TOOLS RECORD SHEET HAVE BEEN RAISED AND ATTACHED.
* APPROVAL HOLDER HAVE VERIFIED THAT ALL TOOLS, EQUIPMENT AND OTHER EXTRANEIOUS PART OF MATERIALS ARE CLEARED AND ALL TASKS OR INSPECTIONS HAVE BEEN CARRIED OUT TO THE REQUIRED STANDARD. TASK HAS BEEN PERFORMED I.A.W MAINTENANCE MANUAL SPECIFIED IN WORKPACK INDEX LM/QA/GEN/01.	

NO	SOURCE	TASK / REFERENCE	REMARKS	MECHANIC SIGN	* AH SIGN & STAMP	DATE
		SUPPORT ASSY P/N 3G5315A28031. PREPARE THE SURFACES TO ASSURE A GOOD GROUND CONTACT.	-	-	-	-
		2.1.9 WITH REFERENCE TO FIGURE 17 VIEW E, INSTALL THE PANEL P/N 3G5315A29151 ON THE RH SUPPORT ASSY P/N 3G5315A28131 AND THE LH SUPPORT ASSY P/N 3G5315A28031 BY MEANS OF N°8 RIVETS P/N NAS1097AD4-5.	SATISFACTORY INSTALLED.			14/2/23
		2.1.10 WITH REFERENCE TO FIGURE 17 VIEW E AND SECTION F-F, DRILL N°4 HOLES Ø4.52÷4.65 THRU THE PANEL P/N 3G5315A29151, THE RH SUPPORT ASSY P/N 3G5315A28131 AND THE LH SUPPORT ASSY P/N 3G5315A28031 IN ACCORDANCE WITH THE DIMENSIONING SHOWN. PREPARE THE SURFACES TO ASSURE A GOOD GROUND CONTACT.	SATISFACTORY DRILLED AND PREPARED.			14/2/23
		2.1.11 WITH REFERENCE TO FIGURE 17 SECTION F-F, INSTALL N°4 NUT PLATES P/N MS21075L06 ON THE PANEL P/N 3G5315A29151 BY MEANS OF N°8 RIVETS P/N MS20426AD3-7.	SATISFACTORY INSTALLED.			14/2/23
		2.1.12 WITH REFERENCE TO FIGURE 18 SECTION G-G AND SECTION H-H, DRILL N°2 HOLES Ø11.48÷11.61 THRU THE PANEL ASSY RH UPPER P/N 3G5315A49131.	SATISFACTORY DRILLED			14/2/23
		2.1.13 WITH REFERENCE TO FIGURE 18 SECTION G-G AND SECTION H-H, INSTALL N°2 INSERTS P/N NAS1836-3-13 ON THE PANEL ASSY RH UPPER P/N 3G5315A49131 BY MEANS OF THE ADHESIVE EA934NA (C397).	SATISFACTORY INSTALLED.			14/2/23
		2.1.14 WITH REFERENCE TO FIGURE 18 SECTION G-G AND SECTION H-H, INSTALL THE BRACKET P/N 3G5315A19551 BY MEANS OF N°2 WASHERS P/N NAS1149D0332K AND N°2 SCREWS P/N MS27039-1-06.	SATISFACTORY INSTALLED.			14/2/23





PARTS / MATERIAL USED / COMPONENT CHANGE RECORD HAVE BEEN RAISED AND ATTACHED.

CALIBRATED / SPECIAL TOOLS RECORD SHEET HAVE BEEN RAISED AND ATTACHED.

* APPROVAL HOLDER HAVE VERIFIED THAT ALL TOOLS, EQUIPMENT AND OTHER EXTRANEIOUS PART OF MATERIALS ARE CLEARED AND ALL TASKS OR INSPECTIONS HAVE BEEN CARRIED OUT TO THE REQUIRED STANDARD. TASK HAS BEEN PERFORMED I.A.W MAINTENANCE MANUAL SPECIFIED IN WORKPACK INDEX LM/QA/GEN/01.

NO	SOURCE	TASK / REFERENCE	REMARKS	MECHANIC SIGN	* AH SIGN & STAMP	DATE
		2.2 WITH REFERENCE TO FIGURE 19 THRU 31, PERFORM EGPWS ELECTRICAL PROVISION P/N 3G3440A00713 AS DESCRIBED IN THE FOLLOWING PROCEDURE:				
		2.2.1 WITH REFERENCE TO FIGURE 23 VIEW LOOKING REAR AREA RH SIDE, REMOVE THE SCREWS P/N MS35207-262, THE WASHERS P/N NAS1149D0332J, AND THE BRACKET P/N A426A01V110A.	Screws REMOVED	<i>[Signature]</i>	<i>ack</i> 	2/3/23
		2.2.2 IN ACCORDANCE WITH AMP DM 39-A-11-00-01-00A-520A-A, AND WITH REFERENCE TO FIGURE 23 VIEW LOOKING REAR AREA RH SIDE, REMOVE THE DATA DECAL P/N ED300GPW.	Screws REMOVED	<i>[Signature]</i>	<i>ack</i> 	2/3/23
		2.2.3 WITH REFERENCE TO FIGURE 23 VIEW LOOKING REAR AREA RH SIDE, INSTALL THE DUST COVER P/N SK3000-2-S879.	Screws INSTALLED	<i>[Signature]</i>	<i>ack</i> 	2/3/23
		2.2.4 IN ACCORDANCE WITH AMP DM 39-A-11-00-01-00A-720A-A, AND WITH REFERENCE TO FIGURE 23 VIEW LOOKING REAR AREA RH SIDE, INSTALL THE DECAL P/N ED300J380.	Screws INSTALLED	<i>[Signature]</i>	<i>ack</i> 	2/3/23
		2.2.5 WITH REFERENCE TO FIGURE 23 VIEW LOOKING REAR AREA RH SIDE, INSTALL IN LOCATION NUMBER 1 THE STUD P/N A366A3E12C.	Screws INSTALLED	<i>[Signature]</i>	<i>ack</i> 	2/3/23
		2.2.6 WITH REFERENCE TO FIGURE 24 DETAIL C, INSTALL THE STUD P/N A388A3E08C (LOCATION N°3).	Screws INSTALLED	<i>[Signature]</i>	<i>ack</i> 	2/3/23

<input checked="" type="checkbox"/> PARTS / MATERIAL USED / COMPONENT CHANGE RECORD HAVE BEEN RAISED AND ATTACHED.	<input type="checkbox"/> CALIBRATED / SPECIAL TOOLS RECORD SHEET HAVE BEEN RAISED AND ATTACHED.
* APPROVAL HOLDER HAVE VERIFIED THAT ALL TOOLS, EQUIPMENT AND OTHER EXTRANEIOUS PART OF MATERIALS ARE CLEARED AND ALL TASKS OR INSPECTIONS HAVE BEEN CARRIED OUT TO THE REQUIRED STANDARD. TASK HAS BEEN PERFORMED I.A.W MAINTENANCE MANUAL SPECIFIED IN WORKPACK INDEX LM/QA/GEN/01.	

NO	SOURCE	TASK / REFERENCE	REMARKS	MECHANIC SIGN	* AH SIGN & STAMP	DATE
		2.2.7 WITH REFERENCE TO FIGURE 24 DETAIL C, INSTALL THE N°2 SUPPORT P/N AW001CLO01-N6 (LOCATIONS N°4 AND N°5).	SATISFACTORY INSTALLED	<i>[Signature]</i>	<i>[Signature]</i> 	26/23
		2.2.8 WITH REFERENCE TO FIGURE 24 VIEW B-B, INSTALL THE ANCHOR NUT P/N AW001TL3A08 (LOCATION N°2).	SATISFACTORY INSTALLED	<i>[Signature]</i>	<i>[Signature]</i> 	26/23
		<p>NOTE</p> <p>CUSTOMER MUST CONTACT LHD ENGINEERING.SUPPORT .LHD@LEONARDO. COM AT LEAST 3 MONTHS IN ADVANCE OF EMBODIMENT DATE OF THIS SERVICE BULLETIN IN ORDER TO COLLECT THE EXACT W/D APPLICABLE TO HELICOPTER CONFIGURATION.</p>	REFER TO PSE/TA/2024/09929 AND WPC 2023/13041/002-189.	<i>[Signature]</i>	<i>[Signature]</i> 	10/3/23
		2.2.9 WITH REFERENCE TO AMP DM 39-A-24-91-04-00A-920A-K, REMOVE FROM THE OVERHEAD CB PANEL THE EXISTING INTEGRALLY-LIT PANEL AND INSTALL THE NEW INTEGRALLY-LIT PANEL P/N 3G2490LXXXXX.				
		2.2.10 INSTALL N°1 CIRCUIT BREAKER P/N MS3320-3 IN THE POSITION INDICATED AS EGPWS ON THE NEW INTEGRALLY-LIT PANEL P/N 3G2490LXXXXX.	SATISFACTORY CB INSTALLED	<i>[Signature]</i>	<i>[Signature]</i> 	26/23
		2.2.11 IN ACCORDANCE WITH AMP DM 39-A-11-00-01-00A-720A-A, APPLY DECAL P/N ED300CB171 IN ADJACENT AREA.	SATISFACTORY APPLIED	<i>[Signature]</i>	<i>[Signature]</i> 	22/2/23

<input checked="" type="checkbox"/> PARTS / MATERIAL USED / COMPONENT CHANGE RECORD HAVE BEEN RAISED AND ATTACHED.	<input type="checkbox"/> CALIBRATED / SPECIAL TOOLS RECORD SHEET HAVE BEEN RAISED AND ATTACHED.
* APPROVAL HOLDER HAVE VERIFIED THAT ALL TOOLS, EQUIPMENT AND OTHER EXTRANEIOUS PART OF MATERIALS ARE CLEARED AND ALL TASKS OR INSPECTIONS HAVE BEEN CARRIED OUT TO THE REQUIRED STANDARD. TASK HAS BEEN PERFORMED I.A.W MAINTENANCE MANUAL SPECIFIED IN WORKPACK INDEX LM/QA/GEN/01.	



Technical Queries - PSE/TQ/2023/99929

Document Reference

Document ID	PSE/TQ/2023/99929	Contact	Stefan Eller
Your Code Reference		Subject	31763 - Service Bulletins (SB) embodiment Aux C/B panel P/N 3G2490L06060
Topic	TECHNICAL	Subtopic	SUPPORT
Issue	TECHNICAL ADVICE	Team Legal Entity	Italy

Contact Details

Customer Description	LEONARDO MALAYSIA SDN BHD	Customer ID	0040000131
Email	stefan.eller@leonardocompany.com		

Customer Service

Priority	HIGH	Creation On (UTC)	28/02/2023
Resolve By (UTC)	04/03/2023	Leonardo Closure Date (UTC)	02/03/2023
Additional Note			

Helicopter Data

ATA Code	24	Description	ELECTRICAL POWER
S/N	N/A	S/N Details	
Helicopter Line	AW139	Helicopter Model	AW139
Repair Instruction Query	False		

Part Number	Component S/N	Component F/H	On (Date)(UTC)
PANEL INTEGRALLY LIGHT AUX BREAKER			

Ticket Description

Dear PSE Team,

MSN 31763 - 392:12 FH, 796 LDG.

Several retro modifications are being fitted to MSN 31763 and this requires a new AUX CB panel to be fitted, SB 139-334, SB 139-348, SB 139-624 and SB 139-665. New CB panel P/N is 3G2490L06060. Refer attachment. Existing AUX CB panel P/N is 3G2490L03966. Refer to attached pictures.

The new AUX CB panel will not arrive in time for the release to service of the aircraft. Estimated RTS is 10th of March 2023.

Please advise possibilities to continue using the existing AUX CB panel for 3 months providing we apply phosphorescent decals with the correct characteristics in accordance with the layout of the new AUX CB panel P/N 3G2490L06060 and installed iaw AMP 39-A-11-00-01-00A-720A-A Decal - Install procedure.

Thank you,

Stefan

History Log

Closing Note

Dear Stefan,

Please refer attached letter to support the helicopter return to service.

Best regards,
Zahin

Ticket Attachments

Attachment's Name	Uploading Date
20230103_094531.jpg	28/02/2023
AW_3G2490L06060_01_A.pdf	28/02/2023
PSE-TQ-2023-99929.pdf	02/03/2023
20230103_094542.jpg	28/02/2023
20230103_094513.jpg	28/02/2023

Our Ref. :	PSE/TQ/2023/99929	Date:	02 March 2023
From :	LH Service Engineering Leonardo Malaysia	engineering.support.lhd@leonardo.com	
TO :	Attn: Eller Stefan stefan.eller@leonardo.com	Page :	1 / 2
SUBJECT :	AW139 S/N 31763 (TT 392:12 FH): Service Bulletins (SB) embodiment Aux C/B panel		

Dear Sir,

With reference to SB139-334, SB139-348, SB139-624 and SB139-665, please be informed that Leonardo Helicopters (LH) technical advice is as follows.

It is possible to use the existing auxiliary circuit breaker panel P/N 3G2490L03966 for three months starting from the completion embodiment of above mentioned SBs or when the spare part will be available, whichever occurs first, provided that the phosphorescent decals with the following characteristics are installed in accordance with the layout of the new panel P/N 3G2490L06060 reported in Annex A:

- Material specification: MIL-M-43719 Type I, Class 1
- Font: Futura Medium Condensed
- Color: Legend in white with black background
- Character height: 3.18 mm

Please be also informed that the above prescriptions must be considered valid only if the aircraft has been maintained in accordance with all Leonardo Helicopters mandatory recommendations, in addition to local authority requirements.

For any additional information do not hesitate to contact LH Service Engineering.

Best Regards,

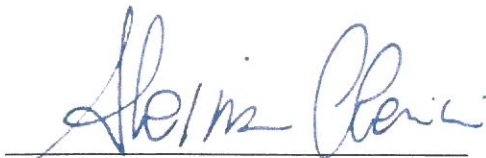

Alessia Clerici
AW139 Chief Project Engineer



Giuseppe Tellone
Service Engineering Area Manager

The technical content of this document is approved under the authority of DOA no. EASA.21J.005. Please note that this document could be subject to approval from Local Airworthiness Authority, depending on the privileges granted to your organization.

[If this document is received incomplete or illegible, please contact engineering.support.lhd@leonardo.com](mailto:engineering.support.lhd@leonardo.com)

This facsimile transmission and any accompanying documents are intended only for confidential use of the designated recipient(s) named above. This message may be proprietary information belonging to Leonardo Helicopters. Any such information is privileged and confidential. If you are not the intended recipient or an agent responsible for delivering it to the intended recipient, any disclosure, copying, distribution or action taken in reliance of the contents of the information contained in this facsimile transmission is strictly prohibited. If you have received this transmission in error, please contact us and will arrange for the return of the documents to us at our expense

Leonardo - Società per azioni

Registered Head Office:

Piazza Monte Grappa, 4 - 00195 Rome - Italy

Ph. +39 06 324731 - Fax +39 06 3208621

Head Office:

Via Giovanni Agusta, 520 - 21017 Cascina Costa di Samarate (VA) - Italy

Ph. +39 0331 229111 - Fax +39 0331 229605

elicotteri@pec.leonardo.com

Company Share Capital. € 2,543,861,738.00 i.v.

Tax Code & Company Registered no. 00401990585

VAT no. 00881841001





R.E.A. n. 7031

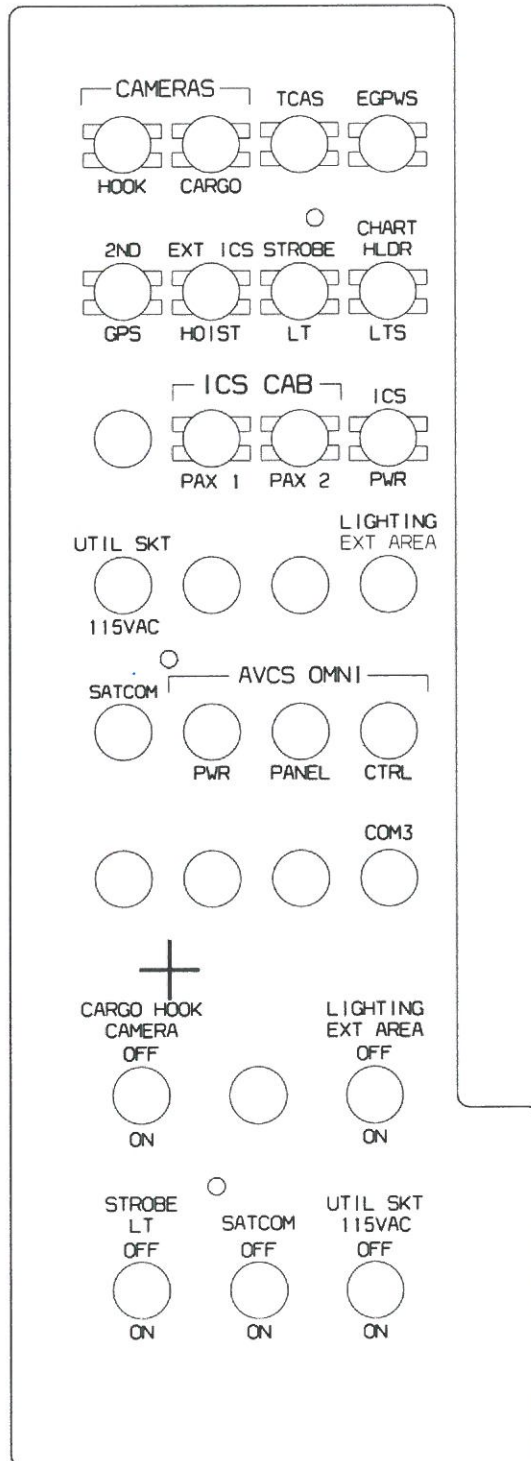

Annex A







Auxiliary circuit breaker panel P/N 3G2490L06060

NO	SOURCE	TASK / REFERENCE	REMARKS	MECHANIC SIGN	* AH SIGN & STAMP	DATE
		2.2.12 ROUTE ONE PIECE OF ELECTRICAL WIRE P/N A556A-T20 OF ADEQUATE LENGTH BETWEEN CIRCUIT BREAKER CB171 AND OVERHEAD CIRCUIT BREAKER PANEL CONNECTOR PL1J4.	SATISFACTORY ROUTED	<i>[Signature]</i>	<i>ack</i> 	22/12/23
		2.2.13 PERFORM ELECTRICAL CONNECTION OF PREVIOUSLY ROUTED WIRE BETWEEN CIRCUIT BREAKER CB171 PIN 2 AND OVERHEAD CIRCUIT BREAKER PANEL CONNECTOR PL1J4 PIN S, RESPECTIVELY BY MEANS OF TERMINAL LUG P/N MS25036-149 AND ELECTRICAL CONTACT P/N M39029/56-351.	SATISFACTORY PERFORMED	<i>[Signature]</i>	<i>ack</i> 	22/12/23
		2.2.14 CONNECT CB171 TO 28V DC MAIN BUS 2 W22B.	SATISFACTORY CONNECTED	<i>[Signature]</i>	<i>ack</i> 	22/12/23
		2.2.15 PERFORM A PIN-TO-PIN CONTINUITY CHECK OF ALL THE ELECTRICAL CONNECTIONS MADE.	SATISFACTORY PERFORMED	<i>ack</i>	<i>ack</i> 	23/12/23
		<p>NOTE</p> <p>USE THE EDGING P/N A236A ON EDGES WHICH ARE LIABLE TO CAUSE DAMAGE TO CABLE ASSEMBLIES OR WHERE ABRASION MAY OCCUR.</p> <p>NOTE</p> <p>INSTALL THE TUBING BRAIDED P/N A582A WHERE PROTECTION AGAINST CHAFING AND PREVENTION OF CONTACT WITH STRUCTURE MAY OCCUR, BUT THE TUBING PROTECTION IS NOT SUBSTITUTE FOR GOOD ROUTING PRACTICE.</p>				

PARTS / MATERIAL USED / COMPONENT CHANGE RECORD HAVE BEEN RAISED AND ATTACHED.

CALIBRATED / SPECIAL TOOLS RECORD SHEET HAVE BEEN RAISED AND ATTACHED.





* APPROVAL HOLDER HAVE VERIFIED THAT ALL TOOLS, EQUIPMENT AND OTHER EXTRANEIOUS PART OF MATERIALS ARE CLEARED AND ALL TASKS OR INSPECTIONS HAVE BEEN CARRIED OUT TO THE REQUIRED STANDARD. TASK HAS BEEN PERFORMED I.A.W MAINTENANCE MANUAL SPECIFIED IN WORKPACK INDEX LM/QA/GEN/01.

NO	SOURCE	TASK / REFERENCE	REMARKS	MECHANIC SIGN	* AH SIGN & STAMP	DATE
		2.2.16 WITH REFERENCE TO FIGURE 19 THRU FIGURE 24, LAY DOWN THE FOLLOWING CABLE ASSEMBLIES ON THE EXISTING ROUTES UNLESS OTHERWISE INDICATED ON THE FIGURES: <ul style="list-style-type: none"> • 3G9A01A26321 EGPWS C/A (A1A263) • 3G9A02A25021 EGPWS C/A (A2A250) • 3G9A01B27421 EGPWS C/A (A1B274) • 3G9A02B25021 EGPWS C/A (A2B250) • 3G9B01B55221 EGPWS C/A (B1B552) • 3G9B02B23821 EGPWS C/A (B2B238) • 3G9C01B22521 EGPWS C/A (C1B225) • 3G9C02B22321 EGPWS C/A (C2B223) • 3G9C02B24221 EGPWS C/A (C2B242) 	SATISFACTORY LAYED	<i>act</i>	<i>act</i> 	2/13/23
		2.2.17 WITH REFERENCE TO FIGURE 19 THRU FIGURE 24, SECURE THE CABLE ASSEMBLIES LAY DOWN AT THE PREVIOUS STEP BY MEANS OF EXISTING HARDWARE AND LACING CORDS.	SATIS SECURED, LACED	<i>act</i>	<i>act</i> 	2/13/23
		2.2.18 WITH REFERENCE TO FIGURE 23 VIEW LOOKING REAR AREA RH SIDE, INSTALL THE CLAMP P/N AW001CB04H ON THE C/A C2B242 BY MEANS OF WASHER P/N NAS1149D0332J AND NUT P/N MS21042L3.	SATIS INSTALLED	<i>act</i>	<i>act</i> 	2/13/23
		2.2.19 WITH REFERENCE TO FIGURE 23 VIEW LOOKING REAR AREA RH SIDE, INSTALL IN INDICATED POSITIONS N°2 CLAMPS P/N AW001CB02H ON THE C/A C2B242 BY MEANS OF THE EXISTING HARDWARE.	SATIS INSTALLED	<i>act</i>	<i>act</i> 	2/13/23
		2.2.20 WITH REFERENCE TO FIGURE 24 DETAIL C, INSTALL THE CLAMP P/N AW001CB04H AND THE CLAMP P/N AW001CB06H ON THE C/A C1B225, C/A C2B223 AND C/A	SATIS INSTALLED	<i>act</i>	<i>act</i> 	2/13/23

PARTS / MATERIAL USED / COMPONENT CHANGE RECORD HAVE BEEN RAISED AND ATTACHED.













CALIBRATED / SPECIAL TOOLS RECORD SHEET HAVE BEEN RAISED AND ATTACHED.

* APPROVAL HOLDER HAVE VERIFIED THAT ALL TOOLS, EQUIPMENT AND OTHER EXTRANEIOUS PART OF MATERIALS ARE CLEARED AND ALL TASKS OR INSPECTIONS HAVE BEEN CARRIED OUT TO THE REQUIRED STANDARD. TASK HAS BEEN PERFORMED I.A.W MAINTENANCE MANUAL SPECIFIED IN WORKPACK INDEX LM/QA/GEN/01.













NO	SOURCE	TASK / REFERENCE	REMARKS	MECHANIC SIGN	* AH SIGN & STAMP	DATE
		C2B242 BY MEANS OF WASHER P/N NAS1149D0332J AND SCREW P/N NAS1190E3P6AK.	-	-	-	-
		2.2.21 WITH REFERENCE TO FIGURE 24 VIEW B-B, INSTALL THE CLAMP P/N AW001CB04H AND THE CLAMP P/N AW001CB06H ON THE C/A C1B225, C/A C2B223 AND C/A C2B242 BY MEANS OF WASHER P/N NAS1149D0332J AND SCREW P/N NAS1801-3-10.	SATISFACTORY INSTALLED	<i>[Signature]</i>	<i>adl</i> 	2/3/23
		2.2.22 IN ACCORDANCE WITH AMP DM 39-A-34-43-03-00A-720A-K AND WITH REFERENCE TO FIGURE 24 DETAIL F, INSTALL THE EGPWS CONFIGURATION MODULE P/N 700-1710-001.	SATISFACTORY INSTALLED	<i>[Signature]</i>	<i>[Signature]</i> 	2/3/23
		2.2.23 WITH REFERENCE TO FIGURE 24 DETAIL F AND DETAIL G, CONNECT THE WIRE P/N A556A-T24 TO THE SHIELD CHAIN A106P2 BY MEANS OF FERRULE P/N A590A02.	SATISFACTORY CONNECTED	<i>[Signature]</i>	<i>[Signature]</i> 	2/3/23
		2.2.24 IN ACCORDANCE WITH AMP DM 39-A-20-10-08-00A-622A-A AND WITH REFERENCE TO FIGURE 20 VIEW LOOKING DOWN RH SIDE, AND FIGURES 27 AND 28 WIRING DIAGRAM, PERFORM THE ELECTRICAL CONNECTIONS BETWEEN THE CONNECTOR A2-3P1 AND THE MODULE TB116-3.	SATISFACTORY PERFORMED	<i>adl</i>	<i>[Signature]</i> 	6/3/23
		2.2.25 IN ACCORDANCE WITH AMP DM 39-A-20-10-08-00A-622A-A AND WITH REFERENCE TO FIGURE 20 VIEW LOOKING DOWN RH SIDE, AND FIGURES 27 AND 28 WIRING DIAGRAM, PERFORM THE ELECTRICAL CONNECTIONS BETWEEN THE CONNECTOR P101 AND THE MODULE TB116-3.	SATIS PERFORMED	<i>adl</i>	<i>adl</i> 	2/7/23

PARTS / MATERIAL USED / COMPONENT CHANGE RECORD HAVE BEEN RAISED AND ATTACHED. CALIBRATED / SPECIAL TOOLS RECORD SHEET HAVE BEEN RAISED AND ATTACHED.

* APPROVAL HOLDER HAVE VERIFIED THAT ALL TOOLS, EQUIPMENT AND OTHER EXTRANEIOUS PART OF MATERIALS ARE CLEARED AND ALL TASKS OR INSPECTIONS HAVE BEEN CARRIED OUT TO THE REQUIRED STANDARD. TASK HAS BEEN PERFORMED I.A.W MAINTENANCE MANUAL SPECIFIED IN WORKPACK INDEX LM/QA/GEN/01.





NO	SOURCE	TASK / REFERENCE	REMARKS	MECHANIC SIGN	* AH SIGN & STAMP	DATE
		2.2.26 IN ACCORDANCE WITH AMP DM 39-A-20-10-08-00A-622A-A AND WITH REFERENCE TO FIGURE 20 VIEW LOOKING DOWN RH SIDE, FIGURE 22 VIEW A-A, AND FIGURES 27 AND 28 WIRING DIAGRAM, PERFORM THE ELECTRICAL CONNECTIONS BETWEEN THE CONNECTOR P106 AND THE JUNCTION MODULE TB116-1.	SATISFACTORY PERFORMED		 	6/3/23
		2.2.27 IN ACCORDANCE WITH AMP DM 39-A-20-10-08-00A-622A-A AND WITH REFERENCE TO FIGURE 21 VIEW LOOKING INSTRUMENT PANEL BACK RH SIDE A.D.O.F., FIGURE 22 VIEW A-A, AND FIGURE 31 WIRING DIAGRAM, PERFORM THE ELECTRICAL CONNECTIONS BETWEEN THE CONNECTOR P106 AND THE JUNCTION MODULE TB150-1.	SATISFACTORY PERFORMED		 	6/3/23
		2.2.28 IN ACCORDANCE WITH AMP DM 39-A-20-10-08-00A-622A-A AND WITH REFERENCE TO FIGURE 20 VIEW LOOKING DOWN RH SIDE, AND FIGURES 27 AND 28 WIRING DIAGRAM, PERFORM THE ELECTRICAL CONNECTIONS BETWEEN THE CONNECTOR TB116-1 AND THE JUNCTION MODULE TB106P1.	SATISFACTORY PERFORMED		 	6/3/23
		2.2.29 IN ACCORDANCE WITH AMP DM 39-A-20-10-08-00A-622A-A AND WITH REFERENCE TO FIGURE 20 VIEW LOOKING DOWN LH SIDE, FIGURE 21 VIEW LOOKING INSTRUMENT PANEL BACK RH SIDE A.D.O.F., AND FIGURES 25 AND 26 WIRING DIAGRAM, PERFORM THE ELECTRICAL CONNECTIONS BETWEEN THE CONNECTOR A1-3P2 AND THE CONNECTOR J113.	SATISFACTORY PERFORMED		 	6/3/23

<input type="checkbox"/> PARTS / MATERIAL USED / COMPONENT CHANGE RECORD HAVE BEEN RAISED AND ATTACHED.	<input type="checkbox"/> CALIBRATED / SPECIAL TOOLS RECORD SHEET HAVE BEEN RAISED AND ATTACHED.
* APPROVAL HOLDER HAVE VERIFIED THAT ALL TOOLS, EQUIPMENT AND OTHER EXTRANEIOUS PART OF MATERIALS ARE CLEARED AND ALL TASKS OR INSPECTIONS HAVE BEEN CARRIED OUT TO THE REQUIRED STANDARD. TASK HAS BEEN PERFORMED I.A.W MAINTENANCE MANUAL SPECIFIED IN WORKPACK INDEX LM/QA/GEN/01.	

NO	SOURCE	TASK / REFERENCE	REMARKS	MECHANIC SIGN	* AH SIGN & STAMP	DATE
		2.2.30 IN ACCORDANCE WITH AMP DM 39-A-20-10-08-00A-622A-A AND WITH REFERENCE TO FIGURE 21 VIEW LOOKING INSTRUMENT PANEL BACK RH SIDE A.D.O.F., AND FIGURES 29 AND 30 WIRING DIAGRAM, PERFORM THE ELECTRICAL CONNECTIONS BETWEEN THE CONNECTOR J113, THE CONNECTOR A95P1 AND THE CONNECTOR A31P1.	SATISFACTORY PERFORMED		 	3/3/23
		2.2.31 IN ACCORDANCE WITH AMP DM 39-A-20-10-08-00A-622A-A AND WITH REFERENCE TO FIGURE 21 VIEW LOOKING INSTRUMENT PANEL BACK RH SIDE A.D.O.F., FIGURE 22 VIEW LOOKING STA 1070 TO STA 3120, AND FIGURES 25 AND 26 WIRING DIAGRAM, PERFORM THE ELECTRICAL CONNECTIONS BETWEEN THE CONNECTOR PL8P2 AND THE CONNECTOR J113.	SATISFACTORY PERFORMED		 	3/3/23
		2.2.32 IN ACCORDANCE WITH AMP DM 39-A-20-10-08-00A-622A-A AND WITH REFERENCE TO FIGURE 20 VIEW LOOKING DOWN RH SIDE, FIGURE 22 VIEW A-A, AND FIGURES 25 AND 26 WIRING DIAGRAM, PERFORM THE ELECTRICAL CONNECTIONS BETWEEN THE CONNECTOR A2-3P2 AND THE CONNECTOR P110.	SATISFACTORY PERFORMED		 	6/3/23
		2.2.33 IN ACCORDANCE WITH AMP DM 39-A-20-10-08-00A-622A-A AND WITH REFERENCE TO FIGURE 21 VIEW LOOKING INSTRUMENT PANEL BACK RH SIDE A.D.O.F., FIGURE 22 VIEW A-A, AND FIGURES 25 AND 26 WIRING DIAGRAM, PERFORM THE ELECTRICAL CONNECTIONS BETWEEN THE CONNECTOR P113 AND THE CONNECTOR P110.	SATISFACTORY PERFORMED		 	6/3/23

<input type="checkbox"/> PARTS / MATERIAL USED / COMPONENT CHANGE RECORD HAVE BEEN RAISED AND ATTACHED.	<input type="checkbox"/> CALIBRATED / SPECIAL TOOLS RECORD SHEET HAVE BEEN RAISED AND ATTACHED.
---	---





* APPROVAL HOLDER HAVE VERIFIED THAT ALL TOOLS, EQUIPMENT AND OTHER EXTRANEIOUS PART OF MATERIALS ARE CLEARED AND ALL TASKS OR INSPECTIONS HAVE BEEN CARRIED OUT TO THE REQUIRED STANDARD. TASK HAS BEEN PERFORMED I.A.W MAINTENANCE MANUAL SPECIFIED IN WORKPACK INDEX LM/QA/GEN/01.

NO	SOURCE	TASK / REFERENCE	REMARKS	MECHANIC SIGN	* AH SIGN & STAMP	DATE
		2.2.34 IN ACCORDANCE WITH AMP DM 39-A-20-10-08-00A-622A-A AND WITH REFERENCE TO FIGURE 21 VIEW LOOKING INSTRUMENT PANEL BACK RH SIDE A.D.O.F., FIGURE 22 VIEW A-A, AND FIGURES 29 AND 30 WIRING DIAGRAM, PERFORM THE ELECTRICAL CONNECTIONS BETWEEN THE CONNECTOR A30P1, THE CONNECTOR A42P1, THE CONNECTOR P113 AND THE CONNECTOR P110.	SATS PERFORMED	adl	adl 	2/13/23
		2.2.35 IN ACCORDANCE WITH AMP DM 39-A-20-10-08-00A-622A-A AND WITH REFERENCE TO FIGURE 20 VIEW LOOKING DOWN RH SIDE, FIGURE 22 VIEW LOOKING STA 1070 TO STA 3120, AND FIGURES 25 AND 26 WIRING DIAGRAM, PERFORM THE ELECTRICAL CONNECTIONS BETWEEN THE CONNECTOR PL24P2 AND THE JUNCTION TB106P1.	SATS PERFORMED	adl	adl 	2/13/23
		2.2.36 IN ACCORDANCE WITH AMP DM 39-A-20-10-08-00A-622A-A AND WITH REFERENCE TO FIGURE 20 VIEW LOOKING DOWN RH SIDE, FIGURE 22 VIEW A-A, AND FIGURES 25 AND 26 WIRING DIAGRAM, PERFORM THE ELECTRICAL CONNECTIONS BETWEEN THE CONNECTOR P110 AND THE JUNCTION TB106P1.	SATS PERFORMED	adl	adl 	2/13/23
		2.2.37 IN ACCORDANCE WITH AMP DM 39-A-20-10-08-00A-622A-A AND WITH REFERENCE TO FIGURE 20 VIEW LOOKING DOWN RH SIDE, FIGURE 21 VIEW LOOKING INSTRUMENT PANEL BACK RH SIDE A.D.O.F., AND FIGURES 25 AND 26 WIRING DIAGRAM, PERFORM THE ELECTRICAL CONNECTIONS BETWEEN THE CONNECTOR P113 AND THE JUNCTION TB106P1.	SATS PERFORMED	adl	adl 	2/13/23

PARTS / MATERIAL USED / COMPONENT CHANGE RECORD HAVE BEEN RAISED AND ATTACHED.

CALIBRATED / SPECIAL TOOLS RECORD SHEET HAVE BEEN RAISED AND ATTACHED.













* APPROVAL HOLDER HAVE VERIFIED THAT ALL TOOLS, EQUIPMENT AND OTHER EXTRANEIOUS PART OF MATERIALS ARE CLEARED AND ALL TASKS OR INSPECTIONS HAVE BEEN CARRIED OUT TO THE REQUIRED STANDARD. TASK HAS BEEN PERFORMED I.A.W MAINTENANCE MANUAL SPECIFIED IN WORKPACK INDEX LM/QA/GEN/01.

NO	SOURCE	TASK / REFERENCE	REMARKS	MECHANIC SIGN	* AH SIGN & STAMP	DATE
		2.2.38 IN ACCORDANCE WITH AMP DM 39-A-20-10-08-00A-622A-A AND WITH REFERENCE TO FIGURE 22 VIEW LOOKING UNDER FLOOR RH SIDE, FIGURE 23 VIEW LOOKING REAR AREA RH SIDE, AND FIGURES 27, 28 AND 29 WIRING DIAGRAM, PERFORM THE ELECTRICAL CONNECTIONS BETWEEN THE CONNECTOR J106 AND THE CONNECTOR J202.	SATISFACTORY PERFORMED	<i>adl</i>	<i>adl</i> 	2/13/23
		2.2.39 IN ACCORDANCE WITH AMP DM 39-A-20-10-08-00A-622A-A AND WITH REFERENCE TO FIGURE 23 VIEW LOOKING REAR AREA RH SIDE, AND FIGURE 31 WIRING DIAGRAM, PERFORM THE ELECTRICAL CONNECTIONS BETWEEN THE MODULE TB2240 AND THE CONNECTOR J202.	SATISFACTORY PERFORMED	<i>TC</i>	<i>TC</i> 	3/13/23
		2.2.40 IN ACCORDANCE WITH AMP DM 39-A-20-10-08-00A-622A-A AND WITH REFERENCE TO FIGURE 22 VIEW LOOKING STA 1070 TO STA 3120, FIGURE 23 VIEW LOOKING REAR AREA RH SIDE, AND FIGURES 25 AND 26 WIRING DIAGRAM, PERFORM THE ELECTRICAL CONNECTIONS BETWEEN THE CONNECTOR PL1P4 AND THE CONNECTOR J202.	SATISFACTORY PERFORMED	<i>adl</i>	<i>adl</i> 	2/13/23
		2.2.41 IN ACCORDANCE WITH AMP DM 39-A-20-10-08-00A-622A-A AND WITH REFERENCE TO FIGURE 22 VIEW LOOKING UNDER FLOOR RH SIDE, FIGURE 23 VIEW LOOKING REAR AREA RH SIDE, AND FIGURES 25, 26, 29 AND 30 WIRING DIAGRAM, PERFORM THE ELECTRICAL CONNECTIONS BETWEEN THE CONNECTOR J110 AND THE CONNECTOR J208.	SATISFACTORY PERFORMED	<i>adl</i>	<i>adl</i> 	2/13/23













PARTS / MATERIAL USED / COMPONENT CHANGE RECORD HAVE BEEN RAISED AND ATTACHED.

CALIBRATED / SPECIAL TOOLS RECORD SHEET HAVE BEEN RAISED AND ATTACHED.

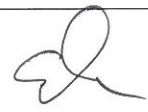
* APPROVAL HOLDER HAVE VERIFIED THAT ALL TOOLS, EQUIPMENT AND OTHER EXTRANEIOUS PART OF MATERIALS ARE CLEARED AND ALL TASKS OR INSPECTIONS HAVE BEEN CARRIED OUT TO THE REQUIRED STANDARD. TASK HAS BEEN PERFORMED I.A.W MAINTENANCE MANUAL SPECIFIED IN WORKPACK INDEX LM/QA/GEN/01.

NO	SOURCE	TASK / REFERENCE	REMARKS	MECHANIC SIGN	* AH SIGN & STAMP	DATE
		2.2.42 IN ACCORDANCE WITH AMP DM 39-A-20-10-08-00A-622A-A AND WITH REFERENCE TO FIGURE 23 VIEW LOOKING REAR AREA RH SIDE, AND FIGURE 24 DETAIL C AND FIGURES 27 AND 28 WIRING DIAGRAM, PERFORM THE ELECTRICAL CONNECTIONS BETWEEN THE DC POWER GROUND TB306, THE GROUND MODULE TB310 AND THE CONNECTOR A106P1.	SATISFACTORY PERFORMED		 	6/3/23
		2.2.43 IN ACCORDANCE WITH AMP DM 39-A-20-10-08-00A-622A-A AND WITH REFERENCE TO FIGURE 23 VIEW LOOKING REAR AREA RH SIDE, AND FIGURE 24 DETAIL C AND TO FIGURE 27 THRU 30 WIRING DIAGRAM, PERFORM THE ELECTRICAL CONNECTIONS BETWEEN THE CONNECTOR P208 AND THE CONNECTOR A106P1.	SATISFACTORY PERFORMED		 	6/3/23
		2.2.44 IN ACCORDANCE WITH AMP DM 39-A-20-10-08-00A-622A-A AND WITH REFERENCE TO FIGURE 23 VIEW LOOKING REAR AREA RH SIDE, AND FIGURE 24 DETAIL C AND FIGURES 27 AND 28 WIRING DIAGRAM, PERFORM THE ELECTRICAL CONNECTIONS BETWEEN THE CONNECTOR P208 AND THE CONNECTOR A106P2.	SATISFACTORY PERFORMED		 	6/3/23
		2.2.45 IN ACCORDANCE WITH AMP DM 39-A-20-10-08-00A-622A-A AND WITH REFERENCE TO FIGURE 23 VIEW LOOKING REAR AREA RH SIDE, AND FIGURE 24 DETAIL C AND FIGURE 31 WIRING DIAGRAM, PERFORM THE ELECTRICAL CONNECTIONS BETWEEN THE DC POWER GROUND TB350 AND THE CONNECTOR A106P3.	SATISFACTORY PERFORMED		 	6/3/23

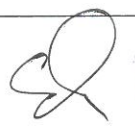
<input type="checkbox"/> PARTS / MATERIAL USED / COMPONENT CHANGE RECORD HAVE BEEN RAISED AND ATTACHED.	<input type="checkbox"/> CALIBRATED / SPECIAL TOOLS RECORD SHEET HAVE BEEN RAISED AND ATTACHED.
* APPROVAL HOLDER HAVE VERIFIED THAT ALL TOOLS, EQUIPMENT AND OTHER EXTRANEIOUS PART OF MATERIALS ARE CLEARED AND ALL TASKS OR INSPECTIONS HAVE BEEN CARRIED OUT TO THE REQUIRED STANDARD. TASK HAS BEEN PERFORMED I.A.W MAINTENANCE MANUAL SPECIFIED IN WORKPACK INDEX LM/QA/GEN/01.	

NO	SOURCE	TASK / REFERENCE	REMARKS	MECHANIC SIGN	* AH SIGN & STAMP	DATE
		2.2.46 WITH REFERENCE TO FIGURE 20 VIEW LOOKING DOWN RH SIDE, VIEW LOOKING OWN LH SIDE AND FIGURE 27 WIRING DIAGRAM, PERFORM THE ELECTRICAL CONNECTION OF THE CONNECTOR A1-3P1 TO THE MODULAR AVIONIC UNIT A1, AND THE CONNECTOR J101 TO THE CONNECTOR P101.	SATISFACTORY PERFORMED		ASR 	6/3/23
		2.2.47 PERFORM A PIN-TO-PIN CONTINUITY CHECK OF ALL THE ELECTRICAL CONNECTIONS MADE.	SATISFACTORY PERFORMED		ASR 	7/3/23
		NOTE SKIP STEPS 2.2.48 AND 2.2.49 IF PART III IS ACCOMPLISHED IMMEDIATELY AFTER PART II.	N/A			
		2.2.48 WITH REFERENCE TO FIGURE 24 DETAIL C AND FIGURE 23 DETAIL D, PROTECT AND STOW THE CONNECTORS C1B225 AND C2B223 BY MEANS OF PROTECTIVE CAPS P/N DCC-15, TIE STRAPS P/N 900004953 AND NOMEX P/N A582A25.	N/A PART 3 COMMENCE IMMEDIATELY	N/A	adl 	14/2/23
		2.2.49 WITH REFERENCE TO FIGURE 24 DETAIL C AND FIGURE 23 DETAIL E, PROTECT AND STOW THE CONNECTOR C2B242 BY MEANS OF PROTECTIVE CAP P/N DCC-12, TIE STRAP P/N 900004953 AND NOMEX P/N A582A25.	N/A PART 3 COMMENCE IMMEDIATELY	N/A	adl 	14/2/23
3	-	RETURN THE HELICOPTER TO FLIGHT CONFIGURATION AND RECORD FOR COMPLIANCE WITH PART II OF THIS SERVICE BULLETIN ON THE HELICOPTER LOGBOOK.	SATISFACTORY RETURNED FOR CAMO TO RECORD AS APPLICABLE.		 	10/3/23
4	-	SEND THE ATTACHED COMPLIANCE FORM TO THE FOLLOWING MAIL BOX: ENGINEERING.SUPPORT.LHD@LEONARDO.COM AS AN ALTERNATIVE, GAIN ACCESS TO MY COMMUNICATIONS SECTION ON LEONARDO WEBPORTAL AND COMPILE THE "SERVICE BULLETIN APPLICATION COMMUNICATION".	FOR PART 2 TO FACE NOTE AND SEND AS APPLICABLE.		 	10/3/23

PARTS / MATERIAL USED / COMPONENT CHANGE RECORD HAVE BEEN RAISED AND ATTACHED.

CALIBRATED / SPECIAL TOOLS RECORD SHEET HAVE BEEN RAISED AND ATTACHED.

* APPROVAL HOLDER HAVE VERIFIED THAT ALL TOOLS, EQUIPMENT AND OTHER EXTRANEIOUS PART OF MATERIALS ARE CLEARED AND ALL TASKS OR INSPECTIONS HAVE BEEN CARRIED OUT TO THE REQUIRED STANDARD. TASK HAS BEEN PERFORMED I.A.W MAINTENANCE MANUAL SPECIFIED IN WORKPACK INDEX LM/QA/GEN/01.

SERVICE BULLETIN**N° 139-665****DATE:** July 8, 2021**REV. :** A - May 31, 2022

TITLE**ATA 34 - ENHANCED GROUND PROXIMITY WARNING SYSTEM INSTALLATION****REVISION LOG**

Helicopters that have complied with previous issue of this Service Bulletin do not need any additional action.

Revision A is issued to:

- Extend the effectivity to AW139 Long Nose helicopters.
- Update the procedure to subdivide the SB in three parts:
 - Part I: complete provision for Long Nose helicopters;
 - Part II: complete provision for Long Nose Enhanced Plus helicopters;
 - Part III: equipment installation (the same for the two configurations).

Due to the large amount of modifications introduced in this new revision, revision bars are not shown.

1. PLANNING INFORMATION

A. EFFECTIVITY

Part I: all AW139 helicopters from S/N 31201 thru S/N 31399 and from S/N 41201 thru S/N 41299.

Part II: all AW139 helicopters from S/N 31700 onwards and from S/N 41500 onwards.

Part III: all AW139 helicopters from S/N 31201 thru S/N 31399, from S/N 41201 thru S/N 41299, from S/N 31700 onwards and from S/N 41500 onwards.

B. COMPLIANCE

At Customer's option.

C. CONCURRENT REQUIREMENTS

N.A.

D. REASON

This Service Bulletin is issued in order to provide the necessary instruction on how to perform the installation of the kit Enhanced Ground Proximity Warning System (EGPWS) -30 P/N 3G3440F00212.

E. DESCRIPTION

Leonardo Helicopters has developed this Service Bulletin in order to install the kit EGPWS P/N 3G3440F00212.

Part I of this Service Bulletin provides information to perform the installation of the EGPWS complete provision P/N 4G3440A00111, that include the structural provision P/N 3G5310A04512 which perform the installation of supports, and the electrical provision P/N 3G3440A00711, which perform the lay down and the connection of the cables.

Part II of this Service Bulletin provides information to perform the installation of the EGPWS complete provision P/N 4G3440A00113, that include the structural provision P/N 3G5310A04513 which perform the installation of supports, and the electrical provision P/N 3G3440A00713, which perform the lay down and the connection of the cables.

Part III provides the information to perform the EGPWS equipment installation P/N 4G3440A00212, which consists of a display controller, a mounting tray and a computer.

F. APPROVAL

The technical content of this Service Bulletin is approved under the authority of DOA nr. EASA.21.J.005. For helicopters registered under other Aviation Authorities, before applying the Service Bulletin, applicable Aviation Authority approval must be checked within Leonardo Helicopters customer portal.

EASA states mandatory compliance with inspections, modifications or technical directives and related time of compliance by means of relevant Airworthiness Directives. If an aircraft listed in the effectivity embodies a modification or repair not LHD certified and affecting the content of this Service Bulletin, it is responsibility of the Owner/Operator to obtain a formal approval by Aviation Authority having jurisdiction on the aircraft, for any adaptation necessary before incorporation of the present Service Bulletin.

G. MANPOWER

To comply with this Service Bulletin, the following MMH are deemed necessary:

Part I: approximately one hundred and twenty-five (125) MMH

Part II: approximately one hundred and twenty-five (125) MMH

Part III: approximately twenty (20) MMH

MMH are based on hands-on time and can change with personnel and facilities available.

H. WEIGHT AND BALANCE

PART I

WEIGHT (Kg)	ARM (mm)	MOMENT (Kgmm)
		3.2
LONGITUDINAL BALANCE	4856	15539.2
LATERAL BALANCE	310	992

PART II

WEIGHT (Kg)	ARM (mm)	MOMENT (Kgmm)
		3.3
LONGITUDINAL BALANCE	4581	15117.3
LATERAL BALANCE	300	990

PART III

WEIGHT (Kg)	3.8
LONGITUDINAL BALANCE	4616
LATERAL BALANCE	126
	MOMENT (Kgmm)
	17540.8
	478.8

I. REFERENCES

1) PUBLICATIONS

Following Data Modules refer to AMP:

<u>DATA MODULE</u>	<u>DESCRIPTION</u>	<u>PART</u>
DM01 39-A-00-20-00-00A-120A-A	Helicopter on ground for a safe maintenance	I, II, III
DM02 39-A-06-41-00-00A-010A-A	Access doors and panels – General data	I, II, III
DM03 39-A-11-00-01-00A-520A-A	Decal remove procedure	I, II, III
DM04 39-A-11-00-01-00A-720A-A	Decal install procedure	I, II, III
DM05 39-A-24-91-04-00A-920A-K	Integrally lighted panel replacement	I, II
DM06 39-A-20-10-08-00A-622A-A	Electrical contacts crimp	I, II
DM07 39-A-34-43-03-00A-720A-K	EGPWS configuration module install procedure	I, II
DM08 39-A-34-43-02-00A-720A-K	EGPWS computer mounting tray install procedure	III
DM09 39-A-34-43-01-00A-720A-K	EGPWS computer install procedure	III
DM10 39-B-31-61-09-00A-720A-A	Number 1 display controller install procedure	III
DM11 39-B-31-61-10-00A-720A-A	Number 2 display controller install procedure	III
DM12 39-A-00-00-00-00A-750A-A	Options and setting file load software procedure	III
DM13 39-B-31-61-00-00A-320B-A	Display controllers operation test	III
DM14 39-B-34-43-00-00A-320A-K	Enhanced ground proximity warning system operation test	III

2) ACRONYMS & ABBREVIATIONS

AMDI	Aircraft Material Data Information
AMP	Aircraft Maintenance Publication
C/A	Cable Assy
CB	Circuit Breaker
DC	Direct Current

DM	Data Module
DOA	Design Organization Approval
EASA	European Aviation Safety Agency
EGPWS	Enhanced Ground Proximity Warning System
IETP	Interactive Electronic Technical Publication
LH	Left-Hand
LHD	Leonardo Helicopters Division
MMH	Maintenance Man Hours
NVG	Night Vision Goggles
P/N	Part Number
RH	Right-Hand
S/N	Serial Number

3) ANNEX

N.A.

J. PUBLICATIONS AFFECTED

N.A.

K. SOFTWARE ACCOMPLISHMENT SUMMARY

Software to be updated:

Primus Epic Option File

Option File P/N is depending upon helicopter configuration that can be different from the one reported in relevant helicopter "Commissa di Vendita". Customer must contact Product Support Engineering (engineering.support.lhd@leonardo.com) to request the correct Option File at least three months in advance from the scheduled embodiment of this Service Bulletin.

2. MATERIAL INFORMATION

A. REQUIRED MATERIALS

1) PARTS

PART I

#	P/N	ALTERNATIVE P/N	DESCRIPTION	Q.TY	LVL	NOTE	LOG P/N
1	3G3440F00212		KIT EGPWS - 30	REF	.		-
2	4G3440A00111		EGPWS COMPLETE PROVISION	REF	..		-
3	3G5310A04512		EGPWS STRUCTURAL PROVISION	REF	...		-
4	3G5315A28031		LH support assy	1		139-665L3
5	3G5315A28131		RH support assy	1		139-665L3
6	3G5315A28451		LH joint	1		139-665L3
7	3G5315A28551		RH joint	1		139-665L3
8	3G5315A29151		Panel	1		139-665L3
9	3G5315A19551	3G5315A19551A1	Bracket	1		139-665L3
10	AGS4719-407	NAS1720H4L2A	Rivet	2		139-665L3
11	AGS4719-508	NAS1720H5L2A	Rivet	48		139-665L3
12	MS20426AD3-7		Rivet	0.1 kg		139-665L3
13	MS21075L06	MS21075L06N	Nut	4		139-665L3
14	NAS1097AD4-5		Rivet	0.1 kg		139-665L3
15	NAS1836-3-13		Insert	2		139-665L3
16	MS27039-1-06		Screw	2		139-665L3
17	NAS1149D0332K		Washer	2		139-665L3
18	3G3440A00711		EGPWS ELECTRICAL PROVISION	REF	...		-
19	3G9A01A26301		EGPWS C/A (A1A263)	1		139-665L3
20	3G9A01B27401		EGPWS C/A (A1B274)	1		139-665L3
21	3G9A02A25002		EGPWS C/A (A2A250)	1		139-665L3
22	3G9A02B25002		EGPWS C/A (A2B250)	1		139-665L3
23	3G9B01B29601	3G3440A00711A10R	EGPWS C/A (B1B296)	1		139-665L3
24	3G9B02B23801		EGPWS C/A (B2B238)	1		139-665L3
25	3G9C01B22501		EGPWS C/A (C1B225)	1		139-665L3
26	3G9C02B22301		EGPWS C/A (C2B223)	1		139-665L3
27	3G9C02B24202		EGPWS C/A (C2B242)	1		139-665L3
28	700-1710-001		Configuration module	1	(1)	-
29	A366A3E12C		Stud	1		139-665L3
30	A388A3E08C		Stud	1		139-665L3
31	AW001CL000A-X3	A630A31	Support	2		139-665L3
32	AW001TL3A08	A630A3B	Anchor nut	1		139-665L3
33	DCC-12		Protective dust	1		139-665L3
34	DCC-15		Protective dust	2		139-665L3
35	ED300EGPWS;DA TA		Decal	1		139-665L3
36	MS21042L3		Nut	1		139-665L3
37	AS21919DG01	MS21919WDG1	Clamp	1		139-665L3
38	AS21919WDG04	MS21919WDG4	Clamp	3		139-665L3
39	MS21919WDG6	AS21919WDG06	Clamp	2		139-665L3
40	NAS1149D0332J		Washer	3		139-665L3
41	A590A02		Ferrule	1		139-665L3
42	NAS1190E3P6AK		Screw	1		139-665L3

#	P/N	ALTERNATIVE P/N	DESCRIPTION	Q.TY	LVL	NOTE	LOG P/N
43	NAS1801-3-10		Screw	1		139-665L3
44	SK3000-2-S879	SK3000/-2	Cover	1		139-665L3
45	MS3320-3		Circuit breaker	1		139-665L3
46	A556A-T20		Electrical wire	2.5 m		139-665L3
47	MS25036-149		Electrical contact	1		139-665L3
48	M39029/56-351		Electrical contact	1		139-665L3
49	ED300CB171		Decal	1		139-665L3
50	3G2490LXXXXX		Integrally lit auxiliary C/B panel	1	(2)	-
51	M39029/56-348		Electrical contact	41		139-665L3
52	M39029/57-354		Electrical contact	19		139-665L3
53	M39029/57-357		Electrical contact	4		139-665L3
54	M39029/58-360		Electrical contact	34		139-665L3
55	M39029/58-363		Electrical contact	6		139-665L3
56	A523A-A05		Electrical contact	1		139-665L3
57	001104-100-02	A523A-A01	Electrical contact	1		139-665L3
58	001104-202-02	A523A-A05	Electrical contact	9		139-665L3
59	M23053/8-004-C		Insulation sleeving	10 m		139-665L3
60	M23053/8-005-C		Insulation sleeving	10 m		139-665L3

PART II

#	P/N	ALTERNATIVE P/N	DESCRIPTION	Q.TY	LVL	NOTE	LOG P/N
61	3G3440F00212		KIT EGPWS - 30	REF	.		-
62	4G3440A00113		EGPWS COMPLETE PROVISION	REF	..		-
63	3G5310A04513		EGPWS STRUCTURAL PROVISION	REF	...		-
64	3G5315A28031		LH support assy	1		139-665L1
65	3G5315A28131		RH support assy	1		139-665L1
66	3G5315A28451		LH joint	1		139-665L1
67	3G5315A28551		RH joint	1		139-665L1
68	3G5315A29151		Panel	1		139-665L1
69	3G5315A19551	3G5315A19551A1	Bracket	1		139-665L1
70	AGS4719-407	NAS1720H4L2A	Rivet	2		139-665L1
71	AGS4719-508	NAS1720H5L2A	Rivet	48		139-665L1
72	MS20426AD3-7		Rivet	0.1 kg		139-665L1
73	MS21075L06	MS21075L06N	Nut	4		139-665L1
74	NAS1097AD4-5		Rivet	0.1 kg		139-665L1
75	NAS1836-3-13		Insert	2		139-665L1
76	MS27039-1-06		Screw	2		139-665L1
77	NAS1149D0332K		Washer	2		139-665L1
78	3G3440A00713		EGPWS ELECTRICAL PROVISION	REF	...		-
79	3G9A01A26321	3G3440A00713A1R	EGPWS C/A (A1A263)	1		139-665L1
80	3G9A02A25021		EGPWS C/A (A2A250)	1		139-665L1
81	3G9A01B27421	3G3440A00713A2R	EGPWS C/A (A1B274)	1		139-665L1
82	3G9A02B25021		EGPWS C/A (A2B250)	1		139-665L1
83	3G9B01B55221	3G3440A00713A3R	EGPWS C/A (B1B552)	1		139-665L1
84	3G9B02B23821		EGPWS C/A (B2B238)	1		139-665L1
85	3G9C01B22521		EGPWS C/A (C1B225)	1		139-665L1
86	3G9C02B22321	3G3440A00713A4R	EGPWS C/A (C2B223)	1		139-665L1
87	3G9C02B24221		EGPWS C/A (C2B242)	1		139-665L1
88	700-1710-001		Configuration module	1	(1)	-
89	A366A3E12C		Stud	1		139-665L1
90	A388A3E08C		Stud	1		139-665L1

#	P/N	ALTERNATIVE P/N	DESCRIPTION	Q.TY	LVL	NOTE	LOG P/N
91	AW001CB02H		Clamp	2		139-665L1
92	AW001CB04H		Clamp	3		139-665L1
93	AW001CB06H		Clamp	2		139-665L1
94	AW001CL001-N6		Support	2		139-665L1
95	AW001TL3A08		Anchor nut	1		139-665L1
96	DCC-12		Protective dust	1		139-665L1
97	DCC-15		Protective dust	2		139-665L1
98	ED300J380		Decal	1		139-665L1
99	MS21042L3		Nut	1		139-665L1
100	NAS1149D0332J		Washer	3		139-665L1
101	A590A02		Ferrule	1		139-665L1
102	NAS1190E3P6AK		Screw	1		139-665L1
103	NAS1801-3-10		Screw	1		139-665L1
104	SK3000-2-S879	SK3000/-2	Cover	1		139-665L1
105	MS3320-3		Circuit breaker	1		139-665L1
106	ED300CB171		Decal	1		139-665L1
107	A556A-T20		Electrical wire	2.5 m		139-665L1
108	MS25036-149		Electrical contact	1		139-665L1
109	M39029/56-351		Electrical contact	5		139-665L1
110	3G2490LXXXXX		Integrally lit auxiliary C/B panel	1	(2)	-
111	M39029/56-348		Electrical contact	41		139-665L1
112	M39029/57-354		Electrical contact	22		139-665L1
113	M39029/57-357		Electrical contact	4		139-665L1
114	M39029/58-360		Electrical contact	34		139-665L1
115	M39029/58-363		Electrical contact	6		139-665L1
116	A523A-A05		Electrical contact	9		139-665L1
117	001104-100-02	A523A-A01	Electrical contact	1		139-665L1
118	001104-202-02	A523A-A05	Electrical contact	8		139-665L1
119	M23053/8-004-C		Insulation sleeving	10 m		139-665L1
120	M23053/8-005-C		Insulation sleeving	10 m		139-665L1

PART III

#	P/N	ALTERNATIVE P/N	DESCRIPTION	Q.TY	LVL	NOTE	LOG P/N
121	3G3440F00212		KIT EGPWS - 30	REF	.		-
122	4G3440A00212		EGPWS EQUIPMENT INSTALLATION	REF	..		-
123	405-0383-001		MK XXII EGPWS mounting tray	1	...	(1)	-
124	7016683-966	7016683-866	Display controller	2	...	(3)	-
125	965-1595-030		EGPWS computer	1	...		139-665L4
126	ED300A106		Decal	1	...		139-665L4
127	MS24693-S30		Screw	2	...		139-665L4
128	MS35206-230		Screw	2	...		139-665L4
129	Primus Epic Option File		SW	1	.	(4)	-

Refer also to IPD for the spares materials required to comply with the AMP DMs referenced in the accomplishment instructions.

2) CONSUMABLES

The following consumable materials, or equivalent, are necessary to accomplish this Service Bulletin:

#	SPEC./LHD CODE NUMBER	DESCRIPTION	Q.TY	NOTE	PART
130	AW001CK03LC	Lacing cord	0.5 m	(5)(6)	I, II
131	900004953	Tape	1	(5)	I, II
132	199-05-002, Type 2, Class II	Adhesive EA934NA (C397)	1	(5)	I, II
133	A582A25 or EN6049-006-25-5	Nomex	1 m	(5)	I, II, III

Refer also to AMDI for the consumable materials required to comply with the AMP DM referenced in the accomplishment instructions.

3) LOGISTIC MATRIX

In order to apply this Service Bulletin, the following Logistic P/N can be ordered in accordance with the applicable notes:

LOGISTIC P/N	Q.TY (PER HELO)	NOTE	PART
139-665L3	1		Part I
700-1710-001	1	(1)	Part I, II
3G2490LXXXXX	1	(2)	Part I, II
139-665L1	1		Part II
139-665L4	1		
405-0383-001	1	(1)	Part III
7016683-866 or 7016683-966	2	(3)	
Primus Epic Option File	1	(4)	

NOTE

- (1) If Part I, or Part II, and Part III are both accomplished, EGPWS Mounting Tray P/N 405-0383-001 and Configuration Module P/N 700-1710-001 will be supplied as Installation Kit P/N 755-7013-007.
- (2) The P/N is not properly completed because it is depending on the helicopter configuration. Customers must contact Product Support Engineering (engineering.support.lhd@leonardo.com) to request the new auxiliary CB panel at least three months in advance from the scheduled application of this Service Bulletin.
- (3) The Display Controller NVG P/N 7016683-866 is the NVG-version and may be used as alternative to the Display Controller P/N 7016683-966 (non-NVG version).
- (4) Refer to software accomplishment summary paragraph.
- (5) Item to be procured as local supply.
- (6) Lacing cord AW001CK03LC may be used as alternative to tape 900004953.

B. SPECIAL TOOLS

Refer to ITEP for the special tools required to comply with the AMP DM referenced in the accomplishment instructions.

C. INDUSTRY SUPPORT INFORMATION

Customization.

3. ACCOMPLISHMENT INSTRUCTIONS

GENERAL NOTES

- a) Place an identification tag on all components that are re-usable, including the attaching hardware that has been removed to gain access to the modification area and adequately protect them until their later re-use.
- b) Shape the cables in order to prevent interference with the structure and the other existing installations, using where necessary suitable lacing cords and plastic cable tiedown.
- c) Exercise extreme care during drilling operations to prevent instruments, cables and hoses damage.
- d) After drilling, remove all swarf and sharp edges. Apply on bare metal a light film of primer unless the hole is used for ground connection.
- e) During the installation of bonding braids or components requiring grounding, clean the surface structure in order to obtain a good ground contact.
- f) Let adhesive cure at room temperature for at least 24 hours unless otherwise specified.
- g) All lengths are in mm.

PART I

NOTE

AW139 S/N 31254 must perform only the following steps: 1, 2.2.15, from 2.2.17 to 2.2.22, 2.2.44, 2.2.48, 3 and 4.

1. In accordance with DM 39-A-00-20-00-00A-120A-A, prepare the helicopter on ground for a safe maintenance. Disconnect the battery, all electrical power sources and/or the external power supply.
2. In accordance with DM 39-A-06-41-00-00A-010A-A and with reference to Figures 1 thru 16, remove all external panels, internal panels and internal liners as required to gain access to the area affected by the installation and perform EGPWS complete provision P/N 4G3440A00111 as described in the following procedure:

- 2.1 With reference to Figure 1 and Figure 2, perform EGPWS structural provision P/N 3G5310A04512 as described in the following procedure:
- 2.1.1 With reference to Figure 1 View B and Detail C, temporarily locate the RH support assy P/N 3G5315A28131, the LH support assy P/N 3G5315A28031, the RH joint P/N 3G5315A28551 and the LH joint P/N 3G5315A28451 on the lower frame STA 7200 P/N 3P5340A10453 and countermark n°48 rivet holes positions.
 - 2.1.2 With reference to Figure 1 View B and Detail C, drill n°48 rivet holes in the previously marked positions thru the lower frame STA 7200 P/N 3P5340A10453. Prepare the surface to assure a good ground contact.
 - 2.1.3 With reference to Figure 1 Detail C, remove the existing rivets from the angle STA 7200 P/N 3P5340A13152 and install the rivets P/N NAS1097AD4-5.
 - 2.1.4 With reference to Figure 1 View B and Detail C, install the RH support assy P/N 3G5315A28131, the LH support assy P/N 3G5315A28031, the RH joint P/N 3G5315A28551 and the LH joint P/N 3G5315A28451 on the lower frame STA 7200 P/N 3P5340A10453 by means of n°48 rivets P/N AGS4719-508.
 - 2.1.5 With reference to Figure 1 View D-D, drill n°1 hole thru the LH joint P/N 3G5315A28451 and LH support assy P/N 3G5315A28031 and n°1 hole thru the RH joint P/N 3G5315A28551 RH support assy P/N 3G5315A28131 in accordance with the dimensioning shown.
 - 2.1.6 With reference to Figure 1 View D-D, fix the RH joint P/N 3G5315A28551 to the RH support assy P/N 3G5315A28131, and the LH joint P/N 3G5315A28451 to the LH support assy P/N 3G5315A28031, by means of n°2 rivets P/N AGS4719-407.
 - 2.1.7 With reference to Figure 1 View E, temporarily locate the panel P/N 3G5315A29151 on the RH support assy P/N 3G5315A28131 and the LH support assy P/N 3G5315A28031 and countermark n°8 rivet holes positions.
 - 2.1.8 With reference to Figure 1 View E, drill n°8 rivet holes in the previously marked positions thru the RH support assy P/N 3G5315A28131 and the LH support assy P/N 3G5315A28031. Prepare the surfaces to assure a good ground contact.

- 2.1.9 With reference to Figure 1 View E, install the panel P/N 3G5315A29151 on the RH support assy P/N 3G5315A28131 and the LH support assy P/N 3G5315A28031 by means of n°8 rivets P/N NAS1097AD4-5.
- 2.1.10 With reference to Figure 1 View E and Section F-F, drill n°4 holes $\varnothing 4.52 \div 4.65$ thru the panel P/N 3G5315A29151, the RH support assy P/N 3G5315A28131 and the LH support assy P/N 3G5315A28031 in accordance with the dimensioning shown. Prepare the surfaces to assure a good ground contact.
- 2.1.11 With reference to Figure 1 Section F-F, install n°4 nut plates P/N MS21075L06 on the panel P/N 3G5315A29151 by means of n°8 rivets P/N MS20426AD3-7.
- 2.1.12 With reference to Figure 2 Section G-G, drill n°2 holes $\varnothing 11.48 \div 11.61$ thru the panel assy RH upper P/N 3G5315A49131.
- 2.1.13 With reference to Figure 2 Section G-G, install n°2 inserts P/N NAS1836-3-13 on the panel assy RH upper P/N 3G5315A49131 by means of the adhesive EA934NA (C397).
- 2.1.14 With reference to Figure 2 Section G-G, install the bracket P/N 3G5315A19551 by means of n°2 washers P/N NAS1149D0332K and n°2 screws P/N MS27039-1-06.
- 2.2 With reference to Figure 3 thru 16, perform EGPWS electrical provision P/N 3G3440A00711 as described in the following procedure:
 - 2.2.1 With reference to Figure 7 View looking rear area RH side, remove the screws P/N MS35207-262, the washers P/N NAS1149D0332J, and the bracket P/N A426A01V110A.
 - 2.2.2 With reference to Figure 7 View looking rear area RH side, install the dust cover P/N SK3000-2-S879.
 - 2.2.3 In accordance with AMP DM 39-A-11-00-01-00A-720A-A, and with reference to Figure 7 View looking rear area RH side, install the decal P/N ED300EGPWS;DATA.
 - 2.2.4 With reference to Figure 7 View looking rear area RH side, install in location n°5 the stud P/N A366A3E12C.
 - 2.2.5 With reference to Figure 9 Detail D, install the stud P/N A388A3E08C (location n°1).
 - 2.2.6 With reference to Figure 9 Detail D, install the n°2 support P/N AW001CL000A-X3 (locations n°3 and n°6)
 - 2.2.7 With reference to Figure 7 View C-C, install in the anchor nut P/N AW001TL3A08 (location n°4).

NOTE

Customer must contact LHD engineering.support.lhd@leonardo.com at least 3 months in advance of embodiment date of this Service Bulletin in order to collect the exact W/D applicable to helicopter configuration.

- 2.2.8 With reference to AMP DM 39-A-24-91-04-00A-920A-K, remove from the Overhead CB panel the existing Integrally-lit panel and install the new integrally-lit panel P/N 3G2490LXXXXX.
- 2.2.9 Install n°1 circuit breaker P/N MS3320-3 in the position indicated as EGPWS on the new integrally-lit panel P/N 3G2490LXXXXX.
- 2.2.10 In accordance with AMP DM 39-A-11-00-01-00A-720A-A, apply decal P/N ED300CB171 in adjacent area.
- 2.2.11 Route one piece of electrical wire P/N A556A-T20 of adequate length between circuit breaker CB171 and overhead circuit breaker panel connector PL1J4.
- 2.2.12 Perform electrical connection of previously routed wire between circuit breaker CB171 pin 2 and overhead circuit breaker panel connector PL1J4 pin S, respectively by means of terminal lug P/N MS25036-149 and electrical contact P/N M39029/56-351.
- 2.2.13 Connect CB171 to 28V DC Main Bus 2 W22B.
- 2.2.14 Perform a pin-to-pin continuity check of all the electrical connections made.

NOTE

Use the edging P/N A236A on edges which are liable to cause damage to cable assemblies or where abrasion may occur.

NOTE

Install the tubing braided P/N A582A where protection against chafing and prevention of contact with structure may occur, but the tubing protection is not substitute for good routing practice.

- 2.2.15 With reference to Figure 3 thru Figure 9, lay down the following cable assemblies on the existing routes unless otherwise indicated on the figures:
 - 3G9A01A26301 EGPWS C/A (A1A263)

- 3G9A01B27401 EGPWS C/A (A1B274)
 - 3G9A02A25002 EGPWS C/A (A2A250)
 - 3G9A02B25002 EGPWS C/A (A2B250)
 - 3G9B01B29601 EGPWS C/A (B1B296)
 - 3G9B02B23801 EGPWS C/A (B2B238)
 - 3G9C01B22501 EGPWS C/A (C1B225)
 - 3G9C02B22301 EGPWS C/A (C2B223)
 - 3G9C02B24202 EGPWS C/A (C2B242)
- 2.2.16 With reference to Figure 3 thru Figure 9, secure the cable assemblies lay down at the previous step by means of existing hardware and lacing cords.
- 2.2.17 With reference to Figure 7 View looking rear area RH side, install the clamp P/N MS21919WDG4 on the C/A C2B242 by means of washer P/N NAS1149D0332J and nut P/N MS21042L3.
- 2.2.18 With reference to Figure 8 View looking rear area LH side, install in indicated positions the clamp P/N AS21919DG01 on the C/A C2B242 and C/A C1B225 by means of the existing hardware.
- 2.2.19 With reference to Figure 9 Detail D, install the clamp P/N MS21919WDG4 and the clamp P/N MS21919WDG6 on the C/A C1B225, C/A C2B223 and C/A C2B242 by means of washer P/N NAS1149D0332J and screw P/N NAS1190E3P6AK.
- 2.2.20 With reference to Figure 7 View C-C, install the clamp P/N MS21919WDG4 and the clamp P/N MS21919WDG6 on the C/A C1B225, C/A C2B223 and C/A C2B242 by means of washer P/N NAS1149D0332J and screw P/N NAS1801-3-10.
- 2.2.21 In accordance with AMP DM 39-A-34-43-03-00A-720A-K and with reference to Figure 9 Detail H, install the EGPWS configuration module P/N 700-1710-001.
- 2.2.22 With reference to Figure 9 Detail H and Detail J, connect the wire P/N A556A-T24 to the shield chain A106P2 by means of ferrule P/N A590A02.
- 2.2.23 In accordance with AMP DM 39-A-20-10-08-00A-622A-A and with reference to Figure 4 View looking down RH side, and Figures 12 and 13 Wiring Diagram, perform the electrical connections between the connector A2-3P1 and the module TB116-3.

- 2.2.24 In accordance with AMP DM 39-A-20-10-08-00A-622A-A and with reference to Figure 4 View looking down RH side, and Figures 12 and 13 Wiring Diagram, perform the electrical connections between the connector P101 and the module TB116-3.
- 2.2.25 In accordance with AMP DM 39-A-20-10-08-00A-622A-A and with reference to Figure 4 View looking down RH side, Figure 8 View B-B, and Figures 12 and 13 Wiring Diagram, perform the electrical connections between the connector P106 and the junction module TB116-1.
- 2.2.26 In accordance with AMP DM 39-A-20-10-08-00A-622A-A and with reference to Figure 5 View looking instrument panel back RH side A.D.O.F., Figure 8 View B-B, and Figure 16 Wiring Diagram, perform the electrical connections between the connector P106 and the junction module TB150-1.
- 2.2.27 In accordance with AMP DM 39-A-20-10-08-00A-622A-A and with reference to Figure 4 View looking down RH side, and Figures 12 and 13 Wiring Diagram, perform the electrical connections between the connector TB116-1 and the junction module TB106P1.
- 2.2.28 In accordance with AMP DM 39-A-20-10-08-00A-622A-A and with reference to Figure 4 View looking down LH side, Figure 6 Detail A, and Figures 10 and 11 Wiring Diagram, perform the electrical connections between the connector A1-3P2 and the connector J113.
- 2.2.29 In accordance with AMP DM 39-A-20-10-08-00A-622A-A and with reference to Figure 5 View looking instrument panel back LH side A.D.O.F., Figure 6 Detail A, and Figures 14 and 15 Wiring Diagram, perform the electrical connections between the connector J113, the connector A95P1 and the connector A31P1.
- 2.2.30 In accordance with AMP DM 39-A-20-10-08-00A-622A-A and with reference to Figure 6 Detail A, View looking STA 1070 to STA 3120, and Figures 10 and 11 Wiring Diagram, perform the electrical connections between the connector PL8P2 and the connector J113.
- 2.2.31 In accordance with AMP DM 39-A-20-10-08-00A-622A-A and with reference to Figure 4 View looking down RH side, Figure 8 View B-B, and Figures 10 and 11 Wiring Diagram, perform the electrical connections between the connector A2-3P2 and the connector P110.
- 2.2.32 In accordance with AMP DM 39-A-20-10-08-00A-622A-A and with reference to Figure 6 Detail A, Figure 8 View B-B, and Figures 10 and

- 11 Wiring Diagram, perform the electrical connections between the connector P113 and the connector P110.
- 2.2.33 In accordance with AMP DM 39-A-20-10-08-00A-622A-A and with reference to Figure 6 Detail A, Figure 8 View B-B, and Figures 14 and 15 Wiring Diagram, perform the electrical connections between the connector A30P1, the connector A42P1, the connector P113 and the connector P110.
- 2.2.34 In accordance with AMP DM 39-A-20-10-08-00A-622A-A and with reference to Figure 4 View looking down RH side, Figure 6 View looking STA 1070 to STA 3120, and Figures 10 and 11 Wiring Diagram, perform the electrical connections between the connector PL24P2 and the junction TB106P1.
- 2.2.35 In accordance with AMP DM 39-A-20-10-08-00A-622A-A and with reference to Figure 4 View looking down RH side, Figure 8 View B-B, and Figures 10 and 11 Wiring Diagram, perform the electrical connections between the connector P110 and the junction TB106P1.
- 2.2.36 In accordance with AMP DM 39-A-20-10-08-00A-622A-A and with reference to Figure 4 View looking down RH side, Figure 6 Detail A, and Figures 10 and 11 Wiring Diagram, perform the electrical connections between the connector P113 and the junction TB106P1.
- 2.2.37 In accordance with AMP DM 39-A-20-10-08-00A-622A-A and with reference to Figure 8 View looking under floor RH side, View looking rear area LH side, and Figures 12, 13 and 16 Wiring Diagram, perform the electrical connections between the connector J106 and the connector J202.
- 2.2.38 In accordance with AMP DM 39-A-20-10-08-00A-622A-A and with reference to Figure 7 View looking STA 5700 RH side, Figure 8 View looking rear area LH side, and Figure 16 Wiring Diagram, perform the electrical connections between the module TB2046 and the connector J202.
- 2.2.39 In accordance with AMP DM 39-A-20-10-08-00A-622A-A and with reference to Figure 6 View looking STA 1070 to STA 3120, Figure 8 View looking rear area LH side, and Figures 10 and 11 Wiring Diagram, perform the electrical connections between the connector PL1P4 and the connector J202.
- 2.2.40 In accordance with AMP DM 39-A-20-10-08-00A-622A-A and with reference to Figure 8 View looking under floor RH side, View looking rear

area LH side, and Figures 10, 11, 14 and 15 Wiring Diagram, perform the electrical connections between the connector J110 and the connector J208.

- 2.2.41 In accordance with AMP DM 39-A-20-10-08-00A-622A-A and with reference to Figure 7 View looking rear area RH side, Figure 8 View looking rear area LH side, and Figure 9 Detail D and Figures 12 and 13 Wiring Diagram, perform the electrical connections between the DC power ground TB306, the ground module TB310 and the connector A106P1.
- 2.2.42 In accordance with AMP DM 39-A-20-10-08-00A-622A-A and with reference to Figure 8 View looking rear area LH side, and Figure 9 Detail D and to Figure 12 thru 15 Wiring Diagram, perform the electrical connections between the connector P208 and the connector A106P1.
- 2.2.43 In accordance with AMP DM 39-A-20-10-08-00A-622A-A and with reference to Figure 8 View looking rear area LH side, and Figure 9 Detail D and Figures 12 and 13 Wiring Diagram, perform the electrical connections between the connector P208 and the connector A106P2.
- 2.2.44 In accordance with AMP DM 39-A-20-10-08-00A-622A-A and with reference to Figure 8 View looking rear area LH side, and Figure 9 Detail D and Figure 16 Wiring Diagram, perform the electrical connections between the DC power ground TB350 and the connector A106P3.
- 2.2.45 With reference to Figure 4 View looking down RH side, View looking down LH side and Figure 12 and 13 Wiring Diagram, perform the electrical connection of the connector A1-3P1 to the modular avionic unit A1, and the connector J101 to the connector P101.
- 2.2.46 Perform a pin-to-pin continuity check of all the electrical connections made.

NOTE

Skip steps 2.2.47 and 2.2.48 if Part III is accomplished immediately after Part I.

- 2.2.47 With reference to Figure 9 Detail D and Figure 9 Detail E, protect and stow the connectors C1B225 and C2B223 by means of protective caps P/N DCC-15, tie straps P/N 900004953 and nomex P/N A582A25.

2.2.48 With reference to Figure 9 Detail D and Figure 9 Detail F, protect and stow the connector C2B242 by means of protective cap P/N DCC-12, tie strap P/N 900004953 and nomex P/N A582A25.

3. Return the helicopter to flight configuration and record for compliance with Part I of this Service Bulletin on the helicopter logbook.
4. Send the attached compliance form to the following mail box:

engineering.support.lhd@leonardo.com

As an alternative, gain access to My Communications section on Leonardo WebPortal and compile the "Service Bulletin Application Communication".

PART II

1. In accordance with DM 39-A-00-20-00-00A-120A-A, prepare the helicopter on ground for a safe maintenance. Disconnect the battery, all electrical power sources and/or the external power supply.
2. In accordance with DM 39-A-06-41-00-00A-010A-A and with reference to Figures 17 thru 31, remove all external panels, internal panels and internal liners as required to gain access to the area affected by the installation and perform EGPWS complete provision P/N 4G3440A00113 as described in the following procedure:
 - 2.1 With reference to Figure 17 and Figure 18, perform EGPWS structural provision P/N 3G5310A04513 as described in the following procedure:
 - 2.1.1 With reference to Figure 17 View B and Detail C, temporarily locate the RH support assy P/N 3G5315A28131, the LH support assy P/N 3G5315A28031, the RH joint P/N 3G5315A28551 and the LH joint P/N 3G5315A28451 on the lower frame STA 7200 P/N 3P5340A10453 and countermark n°48 rivet holes positions.
 - 2.1.2 With reference to Figure 17 View B and Detail C, drill n°48 rivet holes in the previously marked positions thru the lower frame STA 7200 P/N 3P5340A10453. Prepare the surface to assure a good ground contact.
 - 2.1.3 With reference to Figure 17 Detail C, remove the existing rivets from the angle STA 7200 P/N 3P5340A13152 and install the rivets P/N NAS1097AD4-5.
 - 2.1.4 With reference to Figure 17 View B and Detail C, install the RH support assy P/N 3G5315A28131, the LH support assy P/N 3G5315A28031, the RH joint P/N 3G5315A28551 and the LH joint P/N 3G5315A28451 on the lower frame STA 7200 P/N 3P5340A10453 by means of n°48 rivets P/N AGS4719-508.
 - 2.1.5 With reference to Figure 17 View D-D, drill n°1 hole thru the LH joint P/N 3G5315A28451 and LH support assy P/N 3G5315A28031 and n°1 hole thru the RH joint P/N 3G5315A28551 RH support assy P/N 3G5315A28131 in accordance with the dimensioning shown.
 - 2.1.6 With reference to Figure 17 View D-D, fix the RH joint P/N 3G5315A28551 to the RH support assy P/N 3G5315A28131, and the LH joint P/N 3G5315A28451 to the LH support assy P/N 3G5315A28031, by means of n°2 rivets P/N AGS4719-407.
 - 2.1.7 With reference to Figure 17 View E, temporarily locate the panel P/N 3G5315A29151 on the RH support assy P/N 3G5315A28131 and

- the LH support assy P/N 3G5315A28031 and countermark n°8 rivet holes positions.
- 2.1.8 With reference to Figure 17 View E, drill n°8 rivet holes in the previously marked positions thru the RH support assy P/N 3G5315A28131 and the LH support assy P/N 3G5315A28031. Prepare the surfaces to assure a good ground contact.
 - 2.1.9 With reference to Figure 17 View E, install the panel P/N 3G5315A29151 on the RH support assy P/N 3G5315A28131 and the LH support assy P/N 3G5315A28031 by means of n°8 rivets P/N NAS1097AD4-5.
 - 2.1.10 With reference to Figure 17 View E and Section F-F, drill n°4 holes $\varnothing 4.52 \div 4.65$ thru the panel P/N 3G5315A29151, the RH support assy P/N 3G5315A28131 and the LH support assy P/N 3G5315A28031 in accordance with the dimensioning shown. Prepare the surfaces to assure a good ground contact.
 - 2.1.11 With reference to Figure 17 Section F-F, install n°4 nut plates P/N MS21075L06 on the panel P/N 3G5315A29151 by means of n°8 rivets P/N MS20426AD3-7.
 - 2.1.12 With reference to Figure 18 Section G-G and Section H-H, drill n°2 holes $\varnothing 11.48 \div 11.61$ thru the panel assy RH upper P/N 3G5315A49131.
 - 2.1.13 With reference to Figure 18 Section G-G and Section H-H, install n°2 inserts P/N NAS1836-3-13 on the panel assy RH upper P/N 3G5315A49131 by means of the adhesive EA934NA (C397).
 - 2.1.14 With reference to Figure 18 Section G-G and Section H-H, install the bracket P/N 3G5315A19551 by means of n°2 washers P/N NAS1149D0332K and n°2 screws P/N MS27039-1-06.
- 2.2 With reference to Figure 19 thru 31, perform EGPWS electrical provision P/N 3G3440A00713 as described in the following procedure:
- 2.2.1 With reference to Figure 23 View looking rear area RH side, remove the screws P/N MS35207-262, the washers P/N NAS1149D0332J, and the bracket P/N A426A01V110A.
 - 2.2.2 In accordance with AMP DM 39-A-11-00-01-00A-520A-A, and with reference to Figure 23 View looking rear area RH side, remove the data decal P/N ED300GPW.
 - 2.2.3 With reference to Figure 23 View looking rear area RH side, install the dust cover P/N SK3000-2-S879.

- 2.2.4 In accordance with AMP DM 39-A-11-00-01-00A-720A-A, and with reference to Figure 23 View looking rear area RH side, install the decal P/N ED300J380.
- 2.2.5 With reference to Figure 23 View looking rear area RH side, install in location number 1 the stud P/N A366A3E12C.
- 2.2.6 With reference to Figure 24 Detail C, install the stud P/N A388A3E08C (location n°3).
- 2.2.7 With reference to Figure 24 Detail C, install the n°2 support P/N AW001CL001-N6 (locations n°4 and n°5).
- 2.2.8 With reference to Figure 24 View B-B, install the anchor nut P/N AW001TL3A08 (location n°2).

NOTE

Customer must contact LHD engineering.support.lhd@leonardo.com at least 3 months in advance of embodiment date of this Service Bulletin in order to collect the exact W/D applicable to helicopter configuration.

- 2.2.9 With reference to AMP DM 39-A-24-91-04-00A-920A-K, remove from the Overhead CB panel the existing Integrally-lit panel and install the new integrally-lit panel P/N 3G2490LXXXXX.
- 2.2.10 Install n°1 circuit breaker P/N MS3320-3 in the position indicated as EGPWS on the new integrally-lit panel P/N 3G2490LXXXXX.
- 2.2.11 In accordance with AMP DM 39-A-11-00-01-00A-720A-A, apply decal P/N ED300CB171 in adjacent area.
- 2.2.12 Route one piece of electrical wire P/N A556A-T20 of adequate length between circuit breaker CB171 and overhead circuit breaker panel connector PL1J4.
- 2.2.13 Perform electrical connection of previously routed wire between circuit breaker CB171 pin 2 and overhead circuit breaker panel connector PL1J4 pin S, respectively by means of terminal lug P/N MS25036-149 and electrical contact P/N M39029/56-351.
- 2.2.14 Connect CB171 to 28V DC Main Bus 2 W22B.
- 2.2.15 Perform a pin-to-pin continuity check of all the electrical connections made.

NOTE

Use the edging P/N A236A on edges which are liable to cause damage to cable assemblies or where abrasion may occur.

NOTE

Install the tubing braided P/N A582A where protection against chafing and prevention of contact with structure may occur, but the tubing protection is not substitute for good routing practice.

2.2.16 With reference to Figure 19 thru Figure 24, lay down the following cable assemblies on the existing routes unless otherwise indicated on the figures:

- 3G9A01A26321 EGPWS C/A (A1A263)
- 3G9A02A25021 EGPWS C/A (A2A250)
- 3G9A01B27421 EGPWS C/A (A1B274)
- 3G9A02B25021 EGPWS C/A (A2B250)
- 3G9B01B55221 EGPWS C/A (B1B552)
- 3G9B02B23821 EGPWS C/A (B2B238)
- 3G9C01B22521 EGPWS C/A (C1B225)
- 3G9C02B22321 EGPWS C/A (C2B223)
- 3G9C02B24221 EGPWS C/A (C2B242)

2.2.17 With reference to Figure 19 thru Figure 24, secure the cable assemblies lay down at the previous step by means of existing hardware and lacing cords.

2.2.18 With reference to Figure 23 View looking rear area RH side, install the clamp P/N AW001CB04H on the C/A C2B242 by means of washer P/N NAS1149D0332J and nut P/N MS21042L3.

2.2.19 With reference to Figure 23 View looking rear area RH side, install in indicated positions n°2 clamps P/N AW001CB02H on the C/A C2B242 by means of the existing hardware.

2.2.20 With reference to Figure 24 Detail C, install the clamp P/N AW001CB04H and the clamp P/N AW001CB06H on the C/A C1B225, C/A C2B223 and C/A C2B242 by means of washer P/N NAS1149D0332J and screw P/N NAS1190E3P6AK.

2.2.21 With reference to Figure 24 View B-B, install the clamp P/N AW001CB04H and the clamp P/N AW001CB06H on the

- C/A C1B225, C/A C2B223 and C/A C2B242 by means of washer P/N NAS1149D0332J and screw P/N NAS1801-3-10.
- 2.2.22 In accordance with AMP DM 39-A-34-43-03-00A-720A-K and with reference to Figure 24 Detail F, install the EGPWS configuration module P/N 700-1710-001.
- 2.2.23 With reference to Figure 24 Detail F and Detail G, connect the wire P/N A556A-T24 to the shield chain A106P2 by means of ferrule P/N A590A02.
- 2.2.24 In accordance with AMP DM 39-A-20-10-08-00A-622A-A and with reference to Figure 20 View looking down RH side, and Figures 27 and 28 Wiring Diagram, perform the electrical connections between the connector A2-3P1 and the module TB116-3.
- 2.2.25 In accordance with AMP DM 39-A-20-10-08-00A-622A-A and with reference to Figure 20 View looking down RH side, and Figures 27 and 28 Wiring Diagram, perform the electrical connections between the connector P101 and the module TB116-3.
- 2.2.26 In accordance with AMP DM 39-A-20-10-08-00A-622A-A and with reference to Figure 20 View looking down RH side, Figure 22 View A-A, and Figures 27 and 28 Wiring Diagram, perform the electrical connections between the connector P106 and the junction module TB116-1.
- 2.2.27 In accordance with AMP DM 39-A-20-10-08-00A-622A-A and with reference to Figure 21 View looking instrument panel back RH side A.D.O.F., Figure 22 View A-A, and Figure 31 Wiring Diagram, perform the electrical connections between the connector P106 and the junction module TB150-1.
- 2.2.28 In accordance with AMP DM 39-A-20-10-08-00A-622A-A and with reference to Figure 20 View looking down RH side, and Figures 27 and 28 Wiring Diagram, perform the electrical connections between the connector TB116-1 and the junction module TB106P1.
- 2.2.29 In accordance with AMP DM 39-A-20-10-08-00A-622A-A and with reference to Figure 20 View looking down LH side, Figure 21 View looking instrument panel back RH side A.D.O.F., and Figures 25 and 26 Wiring Diagram, perform the electrical connections between the connector A1-3P2 and the connector J113.
- 2.2.30 In accordance with AMP DM 39-A-20-10-08-00A-622A-A and with reference to Figure 21 View looking instrument panel back RH side

- A.D.O.F., and Figures 29 and 30 Wiring Diagram, perform the electrical connections between the connector J113, the connector A95P1 and the connector A31P1.
- 2.2.31 In accordance with AMP DM 39-A-20-10-08-00A-622A-A and with reference to Figure 21 View looking instrument panel back RH side A.D.O.F., Figure 22 View looking STA 1070 to STA 3120, and Figures 25 and 26 Wiring Diagram, perform the electrical connections between the connector PL8P2 and the connector J113.
- 2.2.32 In accordance with AMP DM 39-A-20-10-08-00A-622A-A and with reference to Figure 20 View looking down RH side, Figure 22 View A-A, and Figures 25 and 26 Wiring Diagram, perform the electrical connections between the connector A2-3P2 and the connector P110.
- 2.2.33 In accordance with AMP DM 39-A-20-10-08-00A-622A-A and with reference to Figure 21 View looking instrument panel back RH side A.D.O.F., Figure 22 View A-A, and Figures 25 and 26 Wiring Diagram, perform the electrical connections between the connector P113 and the connector P110.
- 2.2.34 In accordance with AMP DM 39-A-20-10-08-00A-622A-A and with reference to Figure 21 View looking instrument panel back RH side A.D.O.F., Figure 22 View A-A, and Figures 29 and 30 Wiring Diagram, perform the electrical connections between the connector A30P1, the connector A42P1, the connector P113 and the connector P110.
- 2.2.35 In accordance with AMP DM 39-A-20-10-08-00A-622A-A and with reference to Figure 20 View looking down RH side, Figure 22 View looking STA 1070 to STA 3120, and Figures 25 and 26 Wiring Diagram, perform the electrical connections between the connector PL24P2 and the junction TB106P1.
- 2.2.36 In accordance with AMP DM 39-A-20-10-08-00A-622A-A and with reference to Figure 20 View looking down RH side, Figure 22 View A-A, and Figures 25 and 26 Wiring Diagram, perform the electrical connections between the connector P110 and the junction TB106P1.
- 2.2.37 In accordance with AMP DM 39-A-20-10-08-00A-622A-A and with reference to Figure 20 View looking down RH side, Figure 21 View looking instrument panel back RH side A.D.O.F., and Figures 25 and 26 Wiring Diagram, perform the electrical connections between the connector P113 and the junction TB106P1.

- 2.2.38 In accordance with AMP DM 39-A-20-10-08-00A-622A-A and with reference to Figure 22 View looking under floor RH side, Figure 23 View looking rear area RH side, and Figures 27, 28 and 29 Wiring Diagram, perform the electrical connections between the connector J106 and the connector J202.
- 2.2.39 In accordance with AMP DM 39-A-20-10-08-00A-622A-A and with reference to Figure 23 View looking rear area RH side, and Figure 31 Wiring Diagram, perform the electrical connections between the module TB2240 and the connector J202.
- 2.2.40 In accordance with AMP DM 39-A-20-10-08-00A-622A-A and with reference to Figure 22 View looking STA 1070 to STA 3120, Figure 23 View looking rear area RH side, and Figures 25 and 26 Wiring Diagram, perform the electrical connections between the connector PL1P4 and the connector J202.
- 2.2.41 In accordance with AMP DM 39-A-20-10-08-00A-622A-A and with reference to Figure 22 View looking under floor RH side, Figure 23 View looking rear area RH side, and Figures 25, 26, 29 and 30 Wiring Diagram, perform the electrical connections between the connector J110 and the connector J208.
- 2.2.42 In accordance with AMP DM 39-A-20-10-08-00A-622A-A and with reference to Figure 23 View looking rear area RH side, and Figure 24 Detail C and Figures 27 and 28 Wiring Diagram, perform the electrical connections between the DC power ground TB306, the ground module TB310 and the connector A106P1.
- 2.2.43 In accordance with AMP DM 39-A-20-10-08-00A-622A-A and with reference to Figure 23 View looking rear area RH side, and Figure 24 Detail C and to Figure 27 thru 30 Wiring Diagram, perform the electrical connections between the connector P208 and the connector A106P1.
- 2.2.44 In accordance with AMP DM 39-A-20-10-08-00A-622A-A and with reference to Figure 23 View looking rear area RH side, and Figure 24 Detail C and Figures 27 and 28 Wiring Diagram, perform the electrical connections between the connector P208 and the connector A106P2.
- 2.2.45 In accordance with AMP DM 39-A-20-10-08-00A-622A-A and with reference to Figure 23 View looking rear area RH side, and Figure 24 Detail C and Figure 31 Wiring Diagram, perform the electrical connections between the DC power ground TB350 and the connector A106P3.

- 2.2.46 With reference to Figure 20 View looking down RH side, View looking down LH side and Figure 27 Wiring Diagram, perform the electrical connection of the connector A1-3P1 to the modular avionic unit A1, and the connector J101 to the connector P101.
- 2.2.47 Perform a pin-to-pin continuity check of all the electrical connections made.

NOTE

Skip steps 2.2.48 and 2.2.49 if Part III is accomplished immediately after Part II.

- 2.2.48 With reference to Figure 24 Detail C and Figure 23 Detail D, protect and stow the connectors C1B225 and C2B223 by means of protective caps P/N DCC-15, tie straps P/N 900004953 and nomex P/N A582A25.
 - 2.2.49 With reference to Figure 24 Detail C and Figure 23 Detail E, protect and stow the connector C2B242 by means of protective cap P/N DCC-12, tie strap P/N 900004953 and nomex P/N A582A25.
- 3. Return the helicopter to flight configuration and record for compliance with Part II of this Service Bulletin on the helicopter logbook.
 - 4. Send the attached compliance form to the following mail box:

engineering.support.lhd@leonardo.com

As an alternative, gain access to My Communications section on Leonardo WebPortal and compile the "Service Bulletin Application Communication".

PART III

1. In accordance with DM 39-A-00-20-00-00A-120A-A, prepare the helicopter on ground for a safe maintenance. Disconnect the battery, all electrical power sources and/or the external power supply.
2. In accordance with DM 39-A-06-41-00-00A-010A-A and with reference to Figure 32 and Figure 33, remove all external panels, internal panels and internal liners as required to gain access to the area affected by the installation and perform the EGPWS equipment installation P/N 4G3440A00212 as described in the following procedure:
 - 2.1 In accordance with AMP DM 39-A-34-43-02-00A-720A-K, and with reference to Figure 32 and Figure 33 View A, install the EGPWS computer mounting tray P/N 405-0383-001, by means of n°2 screws P/N MS35206-230 and n°2 screws MS24693-S30.

NOTE

Use the edging P/N A236A on edges which are liable to cause damage to cable assemblies or where abrasion may occur.

NOTE

Install the tubing braided P/N A582A where protection against chafing and prevention of contact with structure may occur, but the tubing protection is not substitute for good routing practice.

- 2.2 In accordance with AMP DM 39-A-34-43-01-00A-720A-K, and with reference to Figure 32 and Figure 33 View A, install the EGPWS computer P/N 965-1595-030.
- 2.3 In accordance with AMP DM 39-A-11-00-01-00A-720A-A, and with reference to Figure 33 View A, install the decal P/N ED300A106 on the EGPWS computer P/N 965-1595-030.
- 2.4 In accordance with AMP DM 39-B-31-61-09-00A-720A-A and AMP DM 39-B-31-61-10-00A-720A-A, and with reference to Figure 32 and Figure 33 View B, install the display controllers P/N 7016683-966.

NOTE

Customer must contact AW139 Product Support Engineering engineering.support.lhd@leonardo.com to request the correct Option File at least three months in advance from the scheduled application of this Service Bulletin.

- 2.5 In accordance with AMP DM 39-A-00-00-00-00A-750A-A, ensure that the

applicable Option File has been installed for the S/W kit installation.

- 2.6 In accordance with applicable steps of AMP DM 39-B-31-61-00-00A-320B-A, perform the operation test of the display controllers P/N 7016683-966.
- 2.7 In accordance with AMP DM 39-B-34-43-00-00A-320A-K, perform the operation test of the kit EGPWS-030 P/N 3G3440F00212.
3. Return the helicopter to flight configuration and record for compliance with Part III of this Service Bulletin on the helicopter logbook.
4. Send the attached compliance form to the following mail box:

engineering.support.lhd@leonardo.com

As an alternative, gain access to My Communications section on Leonardo WebPortal and compile the "Service Bulletin Application Communication".

**STRUCTURAL PROVISION FOR EGPWS
3G5310A04512**

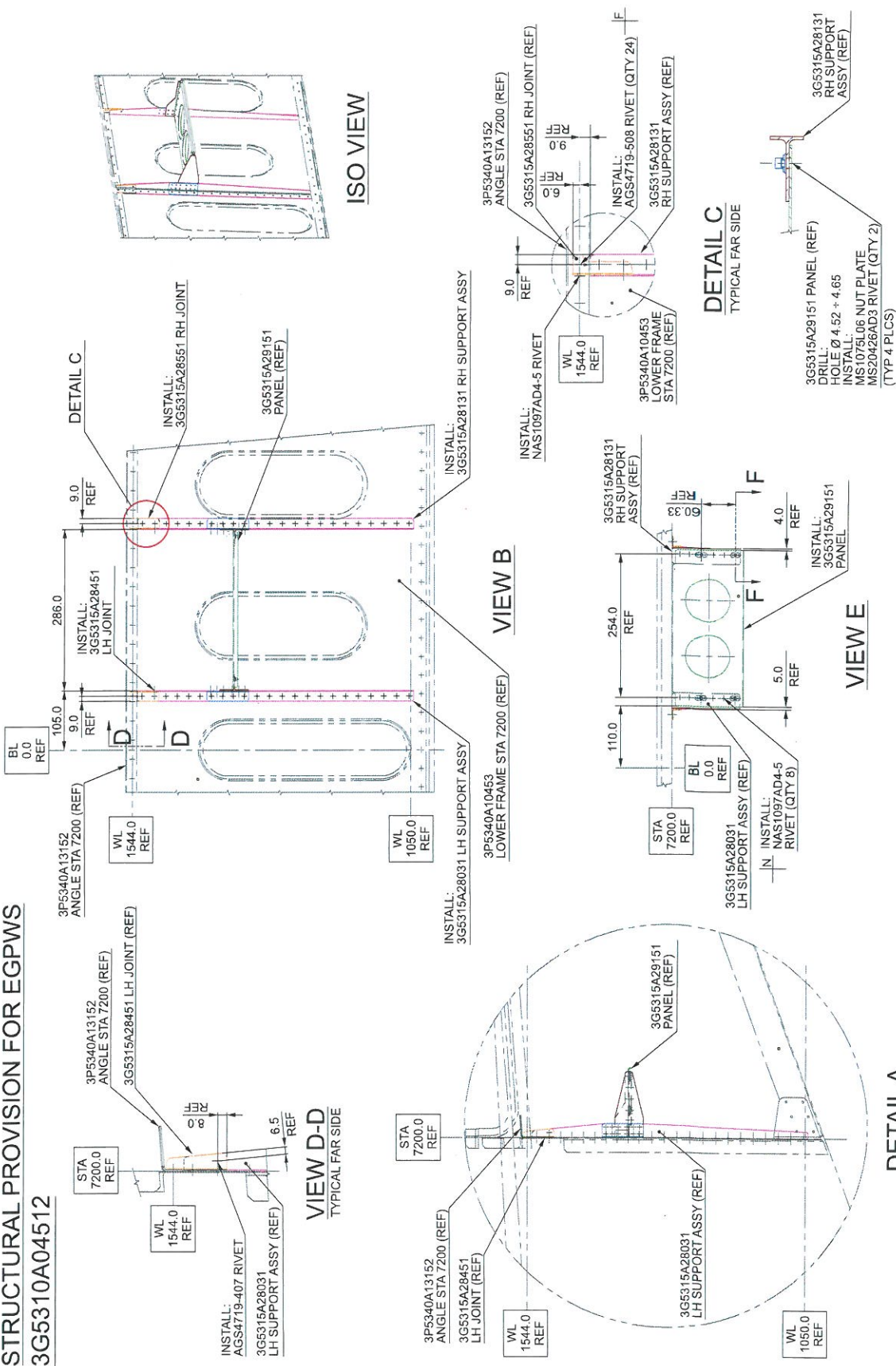

STRUCTURE AND SYSTEMS ARE PARTIALLY OMITTED FOR BETTER CLARITY PURPOSE (REFER TO FIGURE 2)

Figure 1

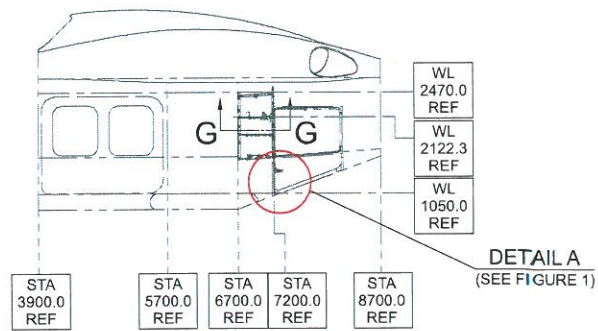

LH VIEW

STRUCTURE AND SYSTEMS ARE PARTIALLY OMITTED FOR BETTER CLARITY PURPOSE

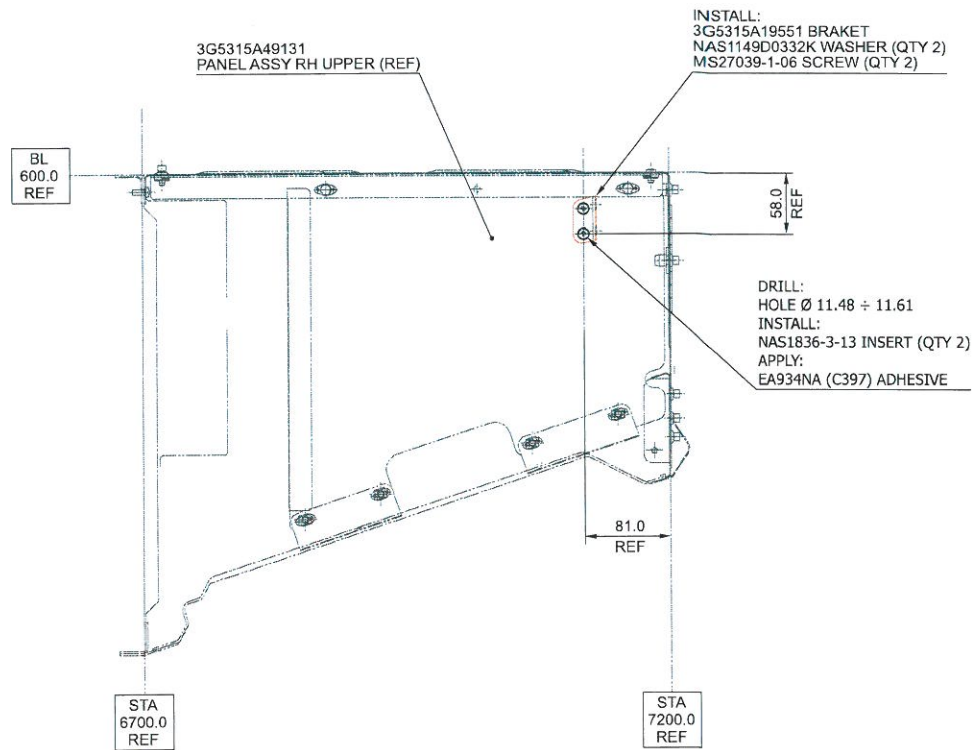

SECTION G-G

Figure 2

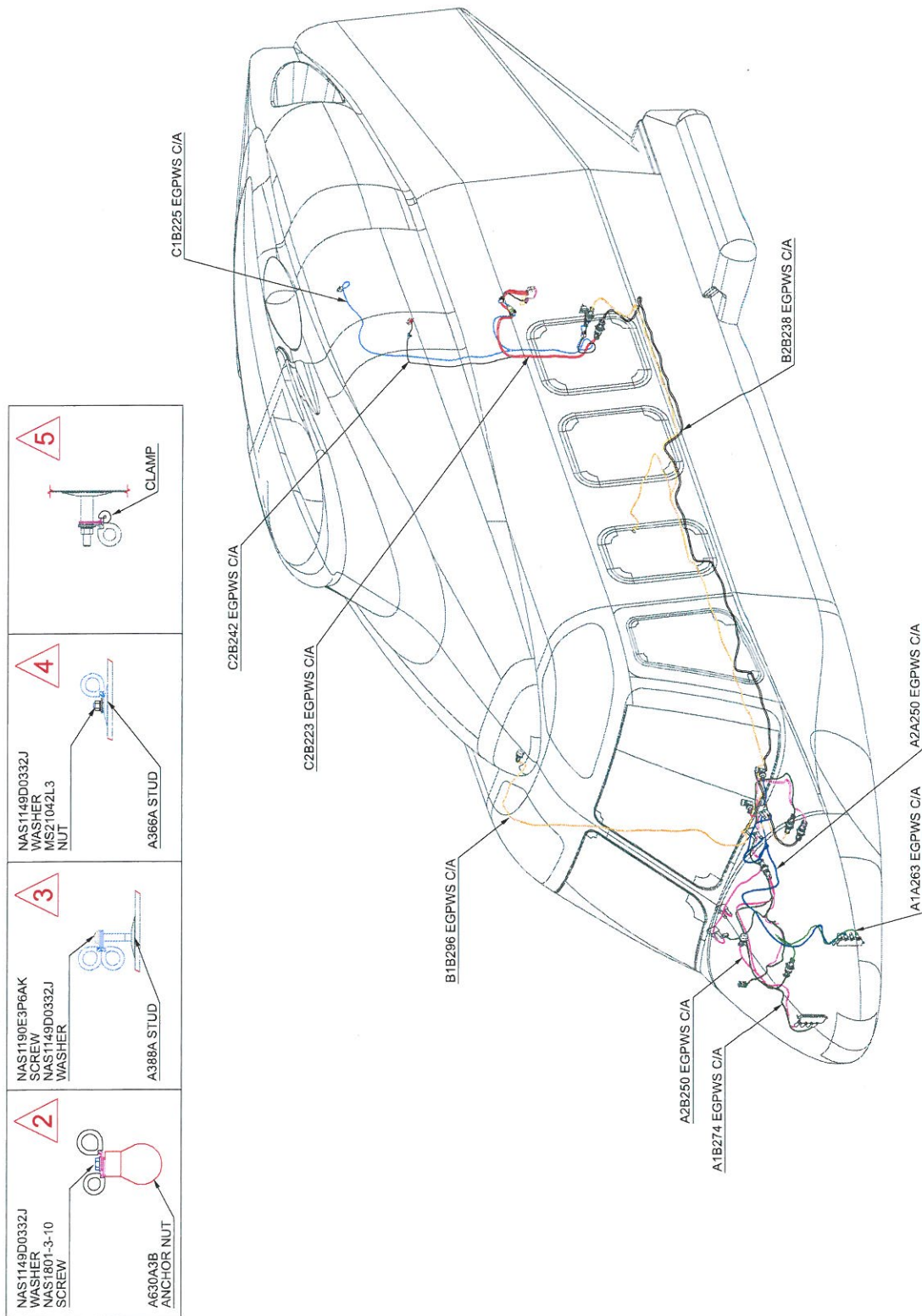

3G3440A00711
EGPWS ELECTRICAL PROVISION

Figure 3

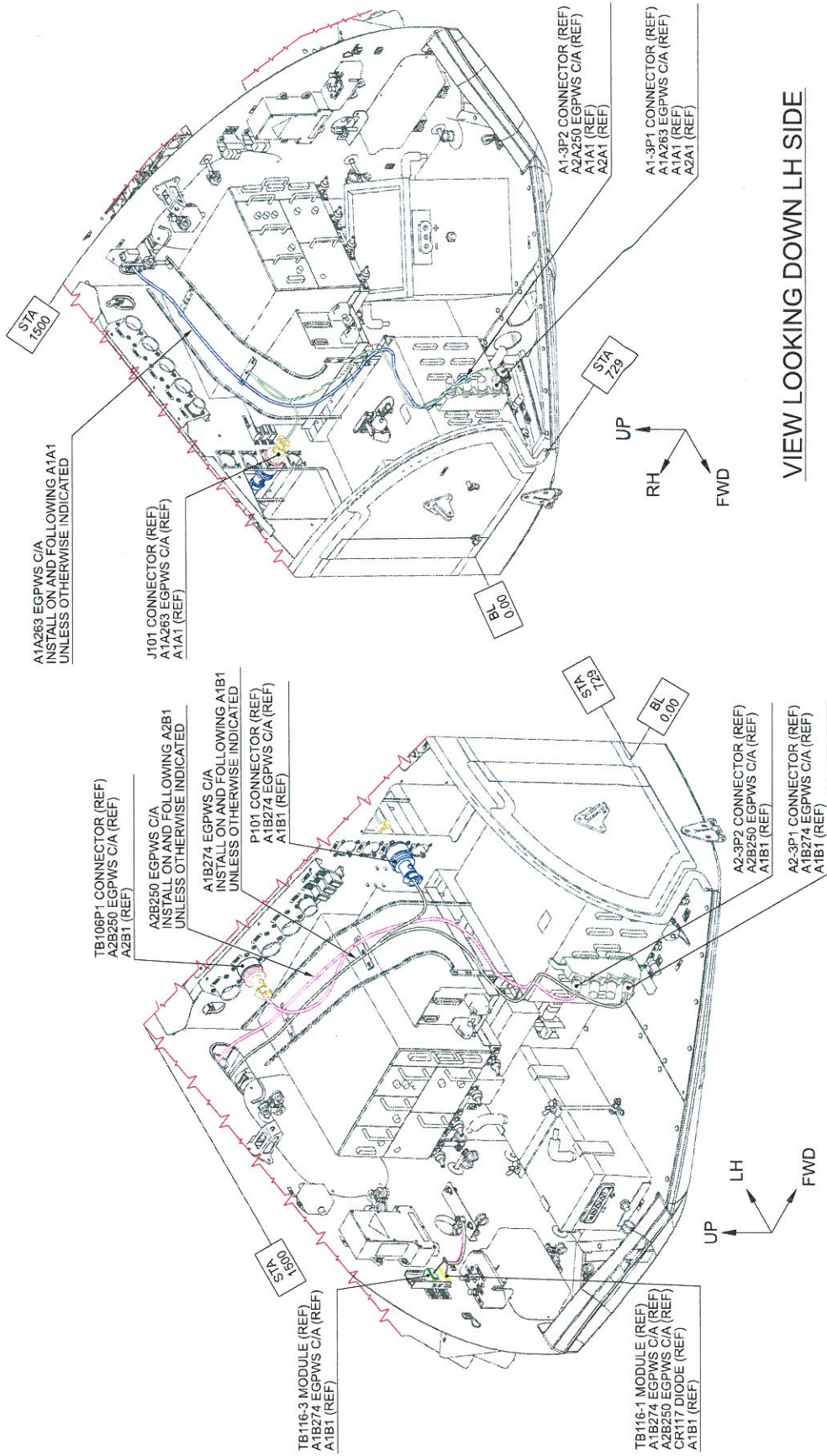

STRUCTURE AND SYSTEMS ARE PARTIALLY OMITTED FOR BETTER CLARITY PURPOSE

Figure 4

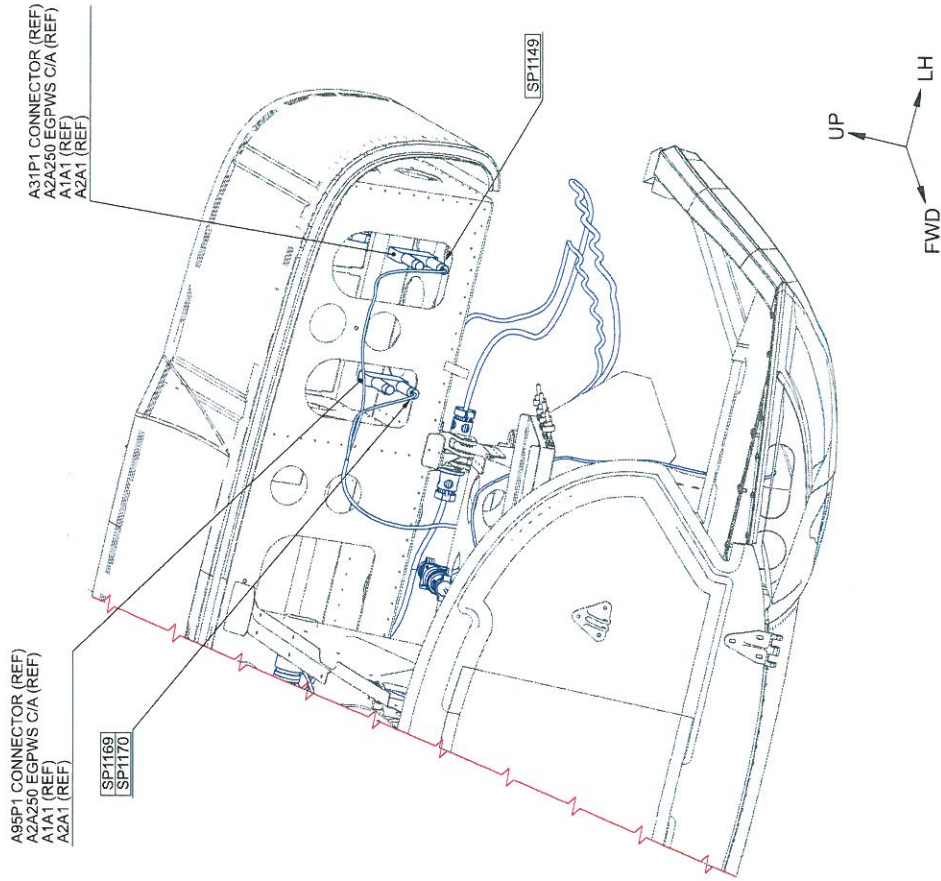

VIEW LOOKING INSTRUMENT PANEL
BACK LH SIDE A.D.O.F.

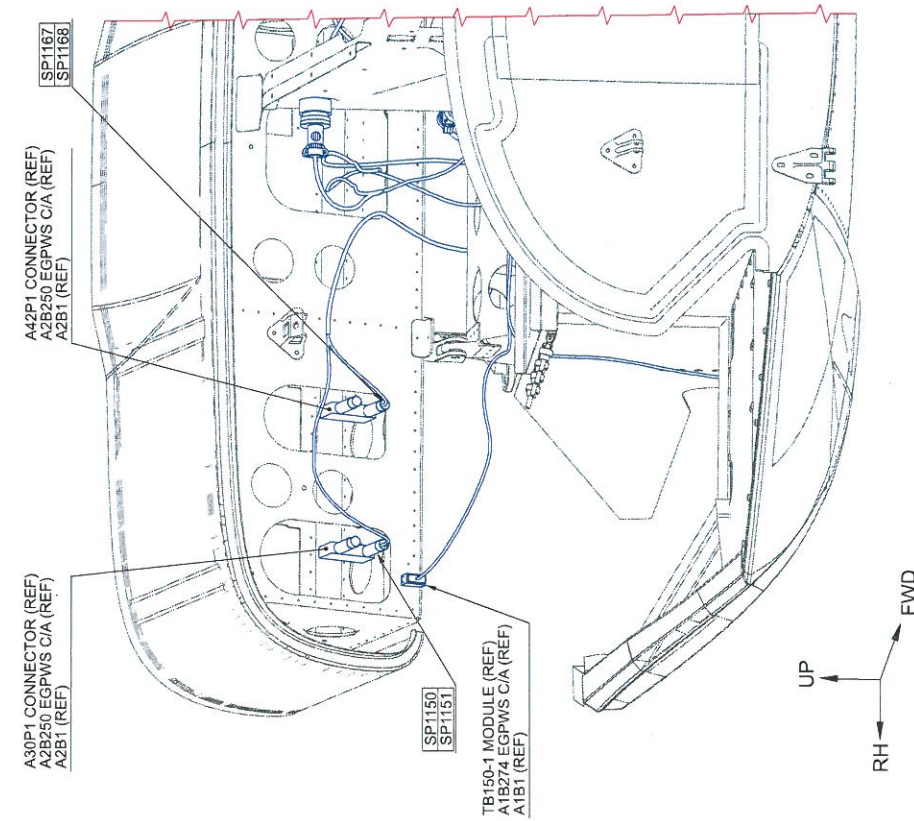

VIEW LOOKING INSTRUMENT PANEL
BACK RH SIDE A.D.O.F.

STRUCTURE AND SYSTEMS ARE PARTIALLY OMITTED FOR BETTER CLARITY PURPOSE

Figure 5

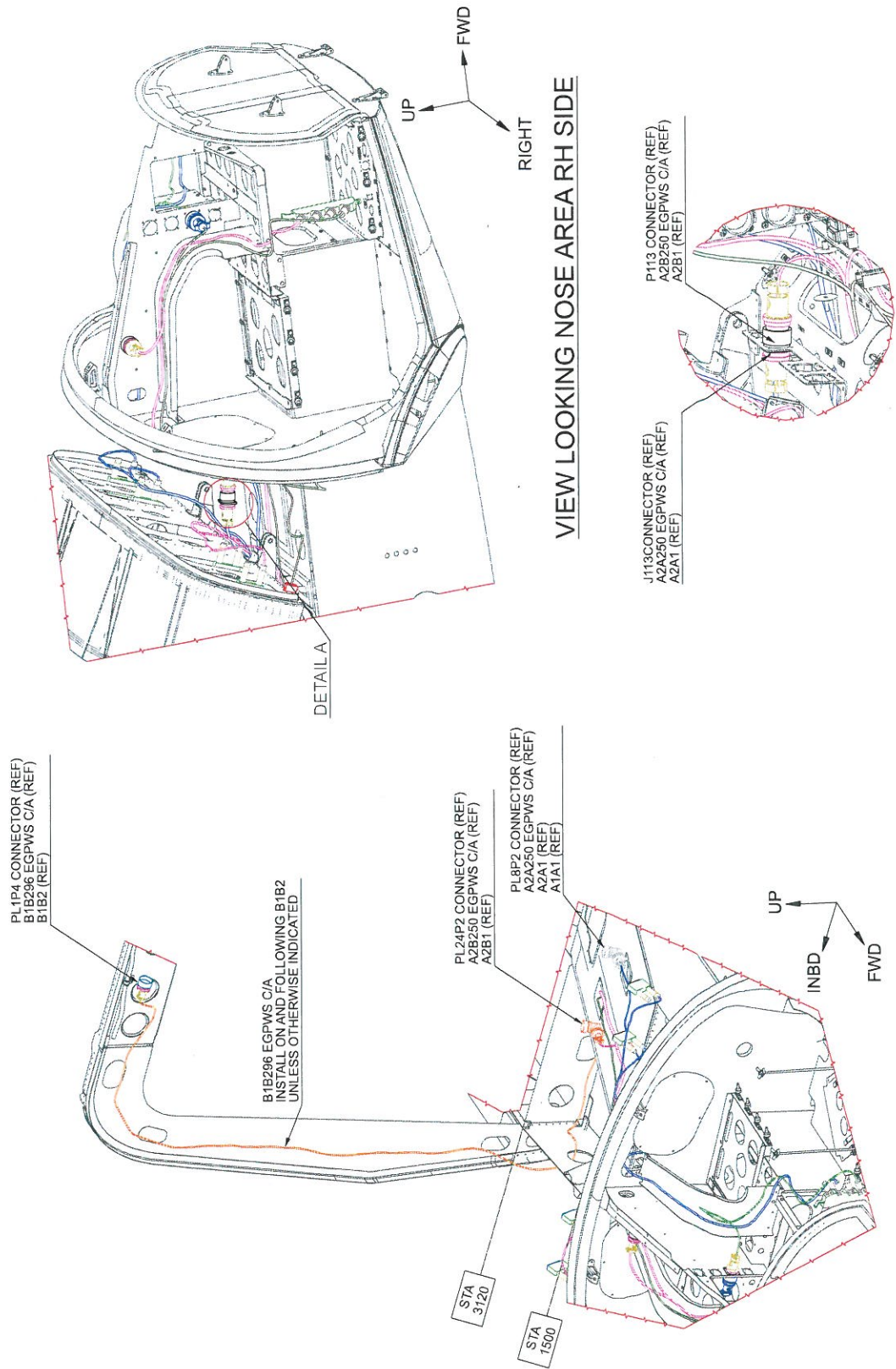

VIEW LOOKING STA 1070 TO STA 3120

STRUCTURE AND SYSTEMS ARE PARTIALLY OMITTED FOR BETTER CLARITY PURPOSE

Figure 6

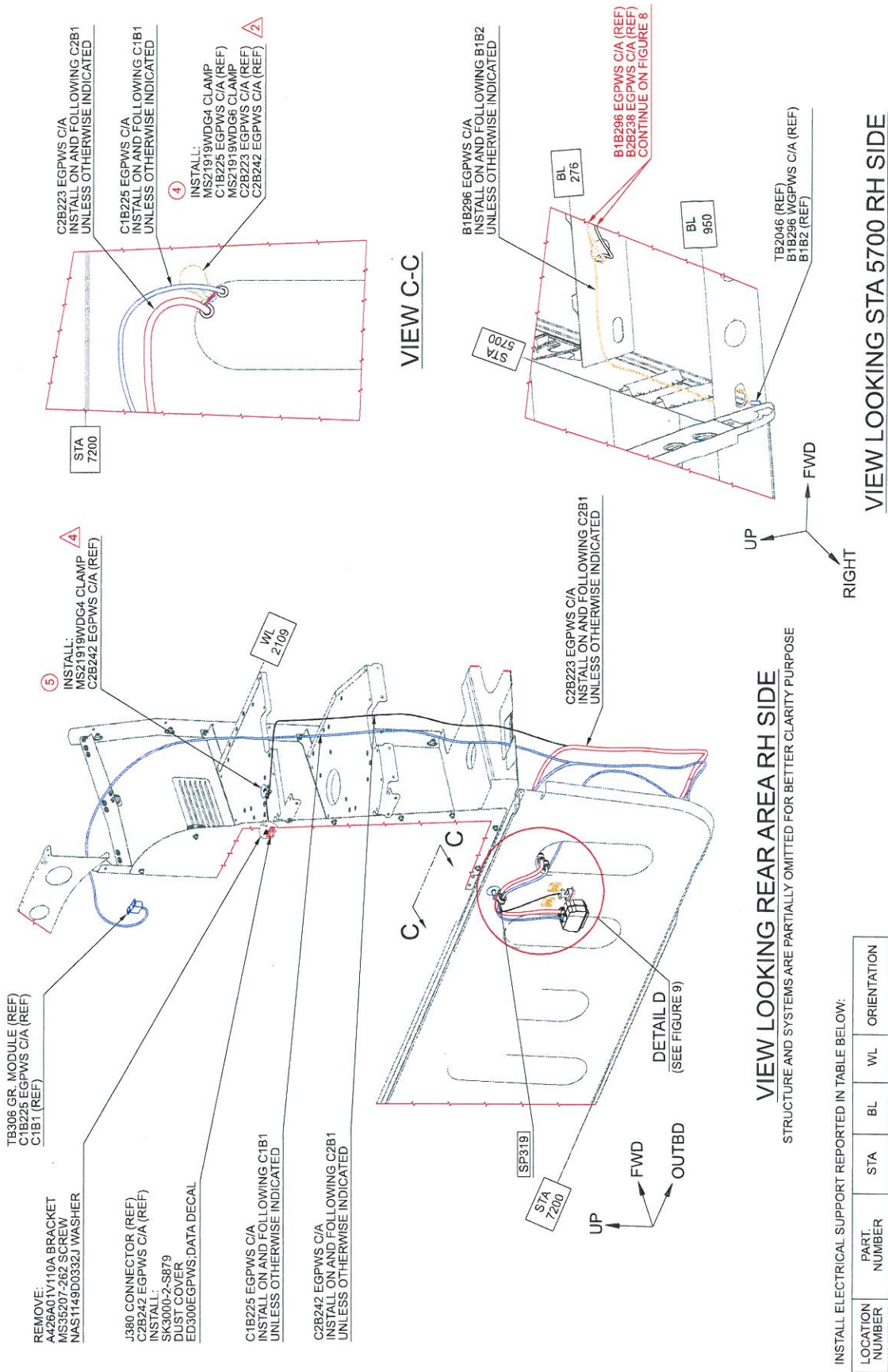

INSTALL ELECTRICAL SUPPORT REPORTED IN TABLE BELOW:

LOCATION NUMBER	PART. NUMBER	STA	BL	WL	ORIENTATION
④	AW001TL3A08	7200	665	1427	135°
⑤	A366A3E12C	7058	759	2106	-

Figure 7

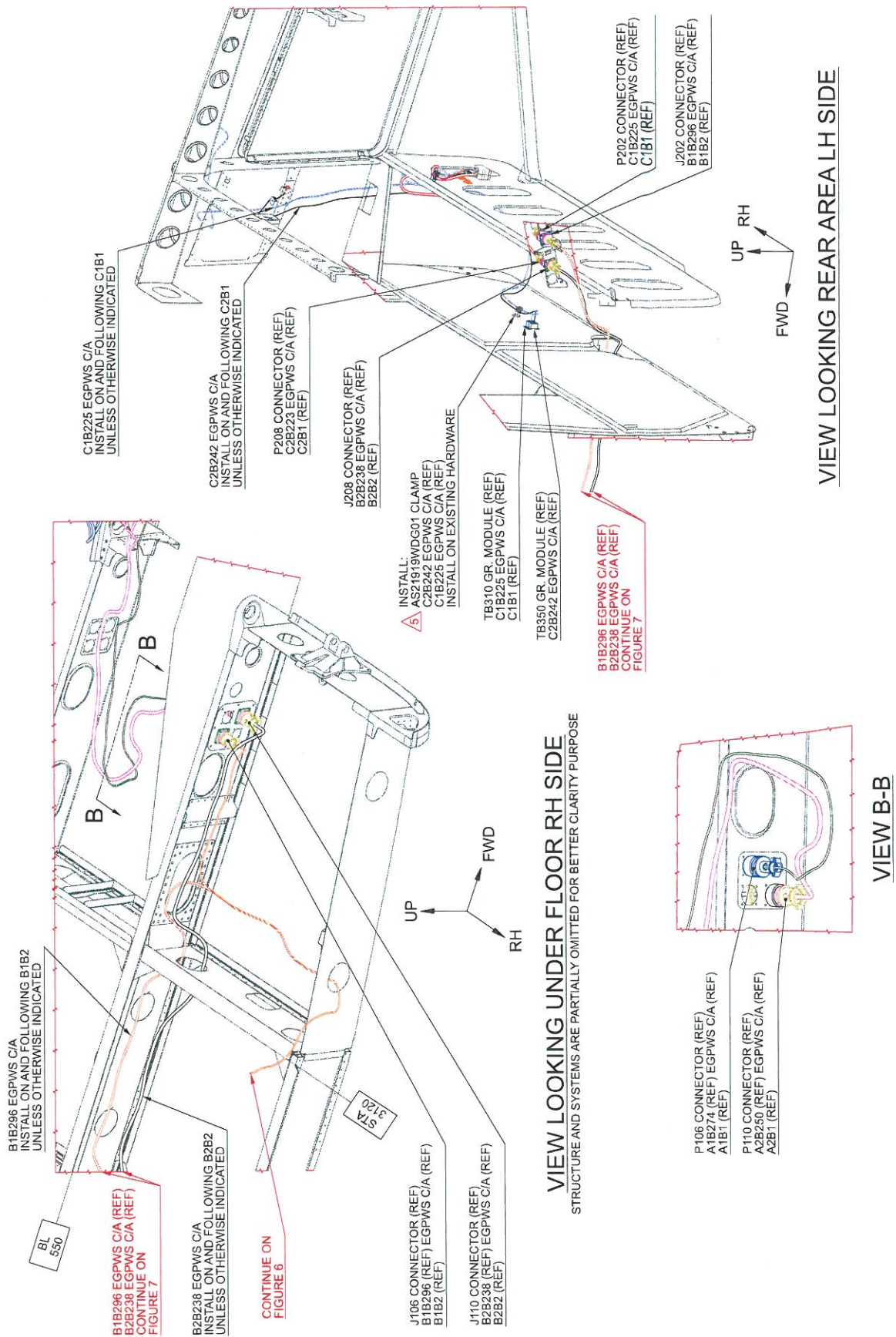
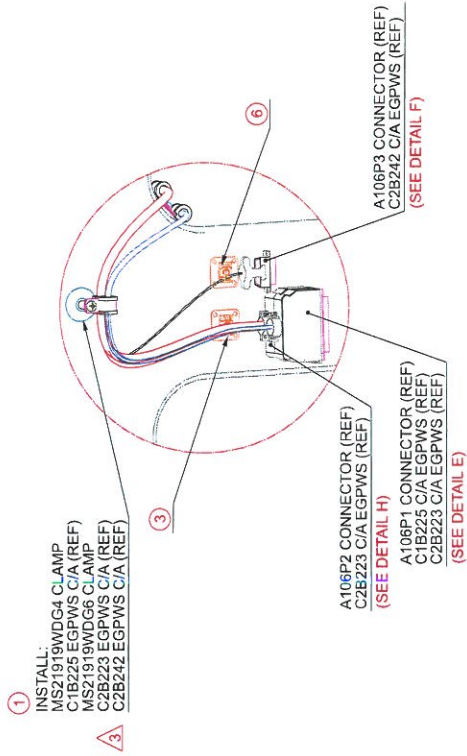
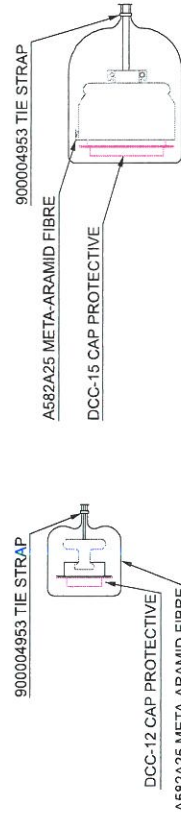

Figure 8



DETAIL D
(REFER TO FIGURE 7)



DETAIL F

DETAIL E

INSTALL ELECTRICAL SUPPORT REPORTED IN TABLE BELOW:

LOCATION NUMBER	PART NUMBER	STA	BL	WL	ORIENTATION
①	A388A3E08C	7200	601	1503	-
③	AW001CL000A-X3	7200	563	1364	0°
⑥	AW001CL000A-X3	7200	613	1364	0°

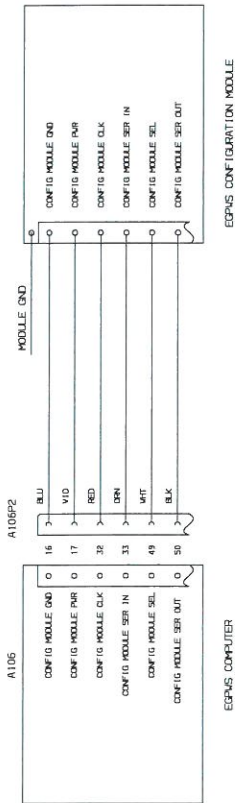

DETAIL J

INSTALL:
700-1710-001 CONFIGURATION MODULE
A556A-T24 GROUND WIRE (REF)

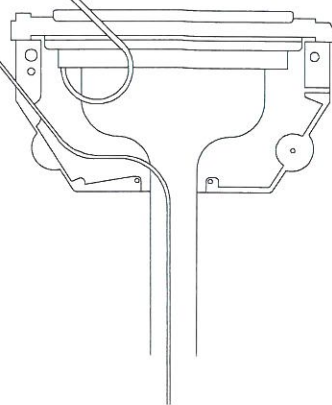

DETAIL H

STRUCTURE AND SYSTEMS ARE PARTIALLY OMITTED FOR BETTER CLARITY PURPOSE

Figure 9

DRAWING REF. KEY
△ SHEET NO. 2

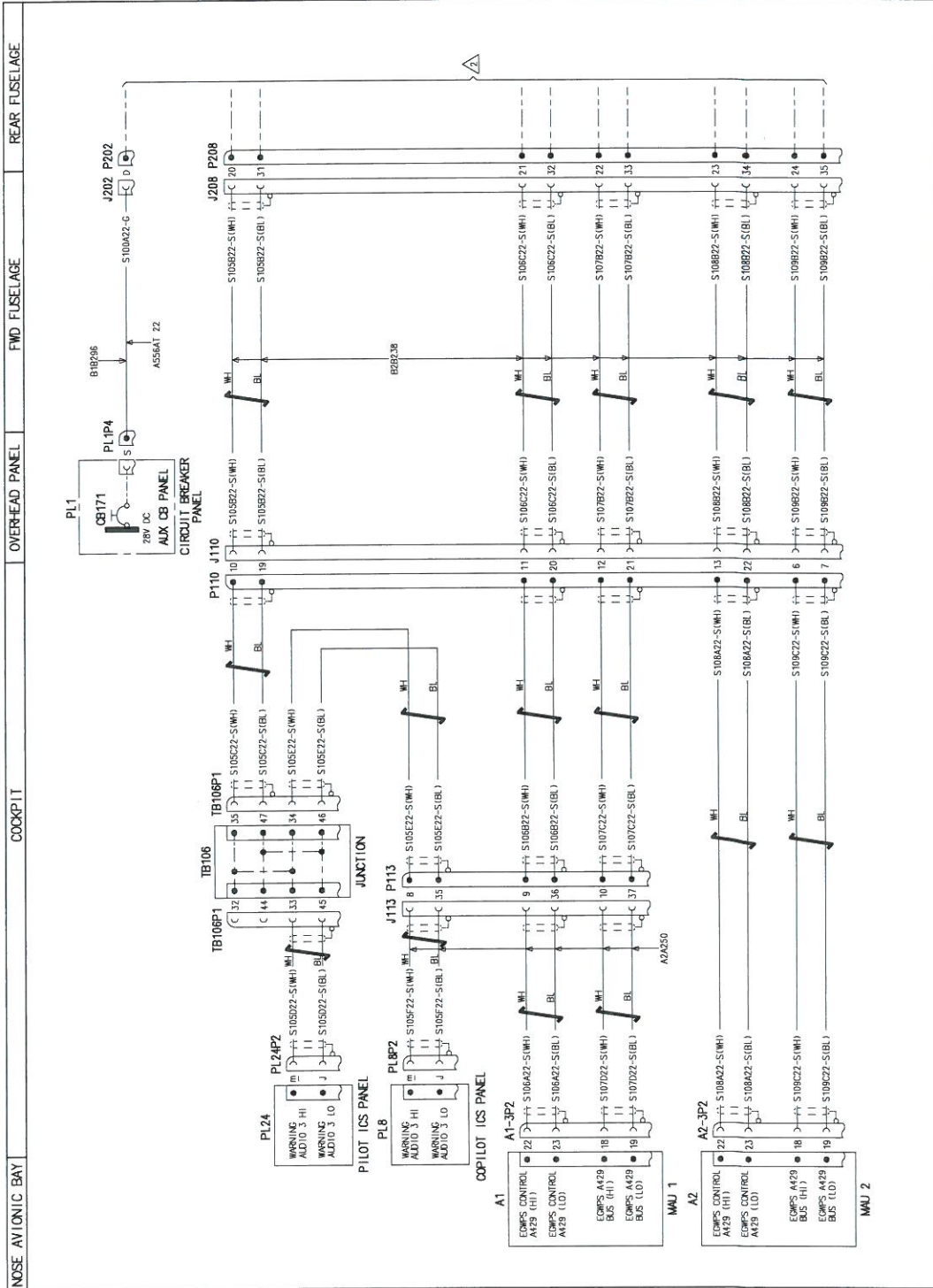

FUNCTIONAL NOTES

ALL CABLES ARE IN LOOM A26330, UNLESS SPECIFIED.
ALL CABLES ARE OF THE A26312 Z2 UNLESS SPECIFIED.

Figure 10

EGPWS C/A (A2B250)

CABLE ASSY	REF-DES	PIN	CONTACT PIN	INSULATION SLEEVING
A2B250	A2-3P2	22	M39029/57-354	M23053/8-004-C
A2B250	A2-3P2	23	M39029/57-354	M23053/8-004-C
A2B250	A2-3P2	18	M39029/57-354	M23053/8-004-C
A2B250	A2-3P2	19	M39029/57-354	M23053/8-004-C
A2B250	P110	13	M39029/58-360	M23053/8-004-C
A2B250	P110	22	M39029/58-360	M23053/8-004-C
A2B250	P110	8	M39029/58-360	M23053/8-004-C
A2B250	P110	7	M39029/58-360	M23053/8-004-C
A2B250	P110	11	M39029/58-360	M23053/8-004-C
A2B250	P110	20	M39029/58-360	M23053/8-004-C
A2B250	P110	12	M39029/58-360	M23053/8-004-C
A2B250	P110	21	M39029/58-360	M23053/8-004-C
A2B250	P110	10	M39029/58-360	M23053/8-004-C
A2B250	P110	19	M39029/58-360	M23053/8-004-C
A2B250	P113	9	M39029/58-360	M23053/8-004-C
A2B250	P113	36	M39029/58-360	M23053/8-004-C
A2B250	P113	10	M39029/58-360	M23053/8-004-C
A2B250	P113	37	M39029/58-360	M23053/8-004-C
A2B250	P113	8	M39029/58-360	M23053/8-004-C
A2B250	P113	35	M39029/58-360	M23053/8-004-C
A2B250	PL24P2	J	M39029/57-357	M23053/8-004-C
A2B250	PL24P2	M	M39029/57-357	M23053/8-004-C
A2B250	TB106P1	45	M39029/56-348	M23053/8-004-C
A2B250	TB106P1	33	M39029/56-348	M23053/8-004-C
A2B250	TB106P1	35	M39029/56-348	M23053/8-004-C
A2B250	TB106P1	47	M39029/56-348	M23053/8-004-C
A2B250	TB106P1	34	M39029/56-348	M23053/8-004-C
A2B250	TB106P1	46	M39029/56-348	M23053/8-004-C

EGPWS C/A (A2A250)

CABLE ASSY	REF-DES	PIN	CONTACT PIN	INSULATION SLEEVING
A2A250	A1-3P2	22	M39029/57-354	M23053/8-004-C
A2A250	A1-3P2	23	M39029/57-354	M23053/8-004-C
A2A250	A1-3P2	18	M39029/57-354	M23053/8-004-C
A2A250	A1-3P2	19	M39029/57-354	M23053/8-004-C
A2A250	PL8P2	M	M39029/57-357	M23053/8-004-C
A2A250	PL8P2	J	M39029/57-357	M23053/8-004-C
A2A250	J113	8	M39029/56-348	M23053/8-004-C
A2A250	J113	35	M39029/56-348	M23053/8-004-C
A2A250	J113	9	M39029/56-348	M23053/8-004-C
A2A250	J113	36	M39029/56-348	M23053/8-004-C
A2A250	J113	10	M39029/56-348	M23053/8-004-C
A2A250	J113	37	M39029/56-348	M23053/8-004-C

EGPWS C/A (B2B238)

CABLE ASSY	REF-DES	PIN	CONTACT PIN	INSULATION SLEEVING
B2B238	J110	10	M39029/56-348	M23053/8-004-C
B2B238	J110	19	M39029/56-348	M23053/8-004-C
B2B238	J110	11	M39029/56-348	M23053/8-004-C
B2B238	J110	20	M39029/56-348	M23053/8-004-C
B2B238	J110	12	M39029/56-348	M23053/8-004-C
B2B238	J110	21	M39029/56-348	M23053/8-004-C
B2B238	J110	13	M39029/56-348	M23053/8-004-C
B2B238	J110	22	M39029/56-348	M23053/8-004-C
B2B238	J110	6	M39029/56-348	M23053/8-004-C
B2B238	J110	7	M39029/56-348	M23053/8-004-C
B2B238	J208	20	M39029/56-348	M23053/8-004-C
B2B238	J208	31	M39029/56-348	M23053/8-004-C
B2B238	J208	21	M39029/56-348	M23053/8-004-C
B2B238	J208	32	M39029/56-348	M23053/8-004-C
B2B238	J208	22	M39029/56-348	M23053/8-004-C
B2B238	J208	33	M39029/56-348	M23053/8-004-C
B2B238	J208	23	M39029/56-348	M23053/8-004-C
B2B238	J208	34	M39029/56-348	M23053/8-004-C
B2B238	J208	24	M39029/56-348	M23053/8-004-C
B2B238	J208	35	M39029/56-348	M23053/8-004-C

EGPWS C/A (B1B296)

CABLE ASSY	REF-DES	PIN	CONTACT PIN	INSULATION SLEEVING
B1B296	J202	D	M39029/56-351	-
B1B296	PL1P4	S	M39029/56-363	-

3G3440W00311
 WIRING DIAGRAM EGPWS
 SHEET 1

Figure 11

DRAWING REF. KEY
△ SHEET NO. 1

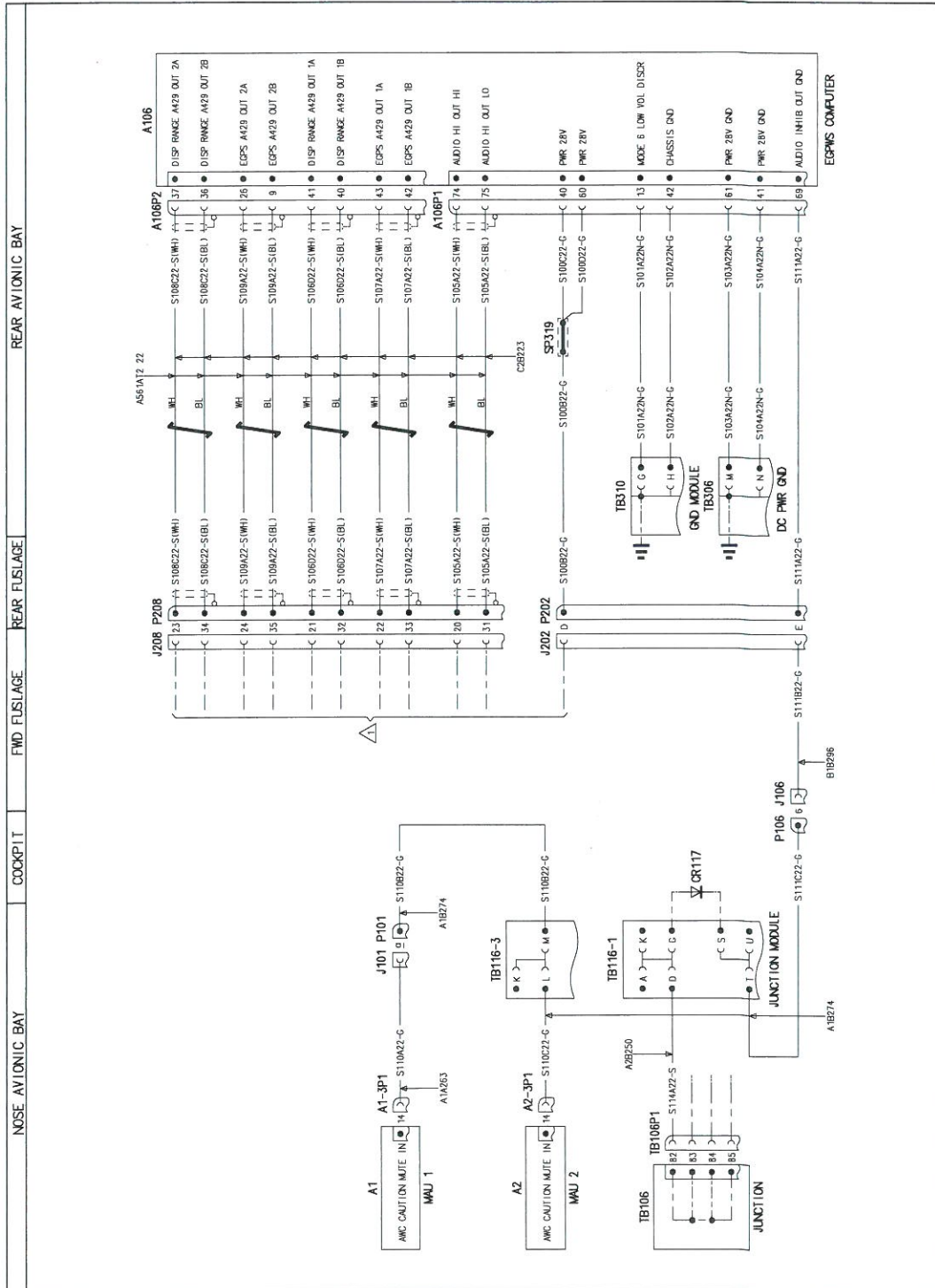

FUNCTIONAL NOTES
ALL CABLES ARE IN LOOM C1B225 UNLESS SPECIFIED.
ALL CABLES ARE OF TYPE ASS0AT 22 UNLESS SPECIFIED

Figure 12

EGPWS C/A (C1B225)

CABLE ASSY	REF-DES	PIN	CONTACT PIN	INSULATION SLEEVING
C1B225	P202	D	M39029/56-363	-
C1B225	P202	E	M39029/56-363	-
C1B225	TB306	N	001104-202-02	-
C1B225	TB306	M	001104-202-02	-
C1B225	TB310	G	001104-202-02	-
C1B225	TB310	H	001104-202-02	-

EGPWS C/A (B1B296)

CABLE ASSY	REF-DES	PIN	CONTACT PIN	INSULATION SLEEVING
B1B296	J106	6	M39029/56-348	-
B1B296	J202	E	M39029/56-351	-

EGPWS C/A (A2B250)

CABLE ASSY	REF-DES	PIN	CONTACT PIN	INSULATION SLEEVING
A2B250	TB106P1	82	M39029/56-348	-
A2B250	TB116-1	D	001104-202-02	-

EGPWS C/A (A1B274)

CABLE ASSY	REF-DES	PIN	CONTACT PIN	INSULATION SLEEVING
A1B274	A2-3P1	14	M39029/57-354	-
A1B274	P101	A	M39029/56-363	-
A1B274	P106	6	M39029/56-360	-
A1B274	TB116-1	T	001104-202-02	-
A1B274	TB116-3	L	001104-202-02	-
A1B274	TB116-3	M	001104-202-02	-

EGPWS C/A (C2B223)

CABLE ASSY	REF-DES	PIN	CONTACT PIN	INSULATION SLEEVING
C2B223	A106P1	74	M39029/57-354	M230538-004-C
C2B223	A106P1	75	M39029/57-354	M230538-004-C
C2B223	P208	20	M39029/56-360	M230538-004-C
C2B223	P208	31	M39029/56-360	M230538-004-C
C2B223	P208	21	M39029/56-360	M230538-004-C
C2B223	P208	32	M39029/56-360	M230538-004-C
C2B223	P208	22	M39029/56-360	M230538-004-C
C2B223	P208	33	M39029/56-360	M230538-004-C
C2B223	P208	23	M39029/56-360	M230538-004-C
C2B223	P208	34	M39029/56-360	M230538-004-C
C2B223	P208	24	M39029/56-360	M230538-004-C
C2B223	P208	35	M39029/56-360	M230538-004-C

EGPWS C/A (A1A263)

CABLE ASSY	REF-DES	PIN	CONTACT PIN	INSULATION SLEEVING
A1A263	A1-3P1	14	M39029/57-354	-
A1A263	J101	A	M39029/56-351	-

3G3440W00311
 WIRING DIAGRAM EGPWS
 SHEET 2

Figure 13

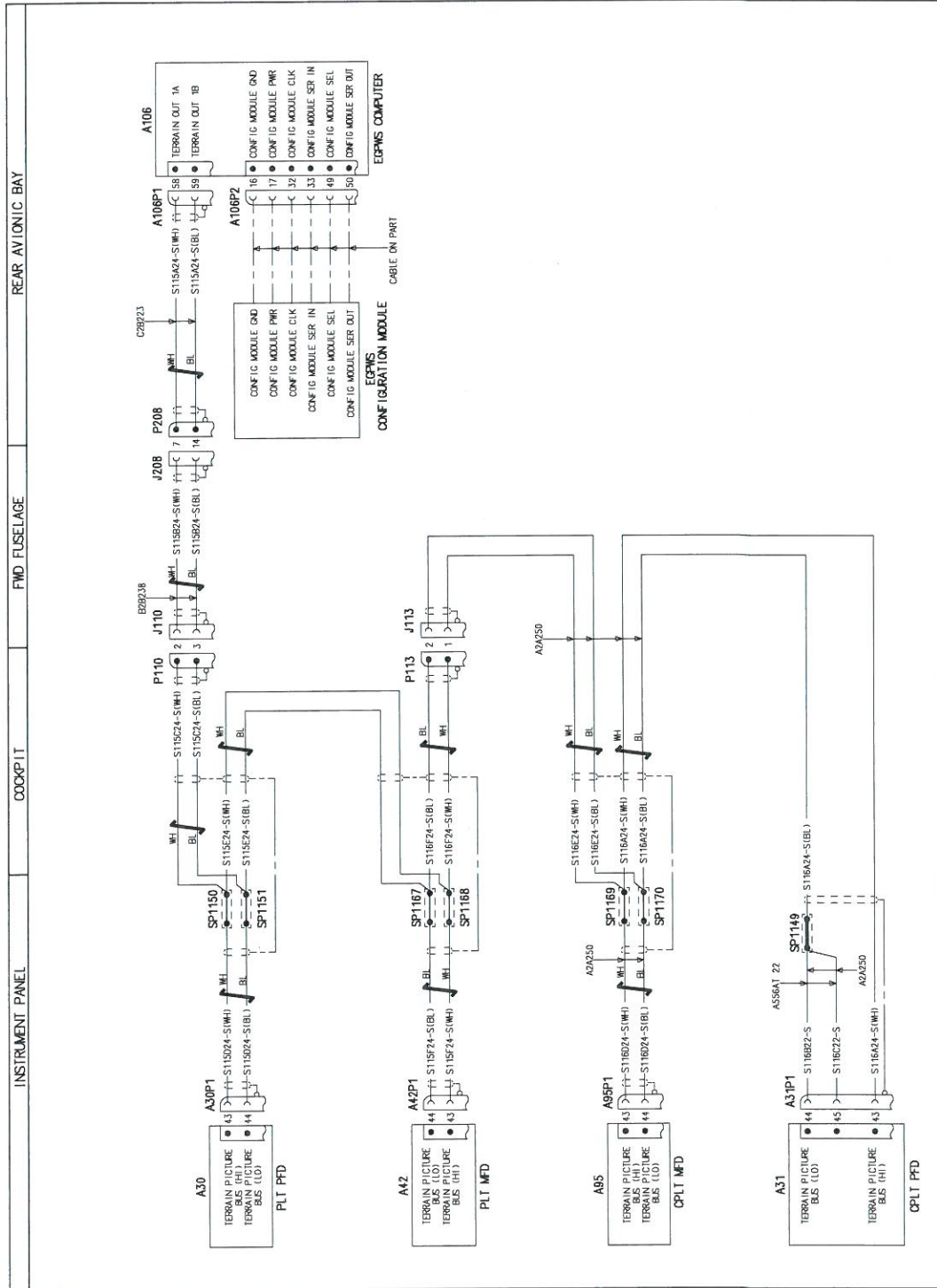

Figure 14

S.B. N°139-665
DATE: July 8, 2021
REVISION: A - May 31, 2022

FUNCTIONAL NOTES
ALL CABLES ARE IN LDM A2925 UNLESS SPECIFIED
ALL CABLES ARE OF TYPE WFT-1/8-0000Z UNLESS SPECIFIED

EGPWS C/A (A2B250)

CABLE ASSY	REF-DES	PIN	CONTACT PIN	INSULATION SLEEVING
A2B250	A30P1	43	M39029/57-354	M23053/8-005-C
A2B250	A30P1	44	M39029/57-354	M23053/8-005-C
A2B250	A42P1	44	M39029/57-354	M23053/8-005-C
A2B250	A42P1	43	M39029/57-354	M23053/8-005-C
A2B250	P110	2	M39029/58-380	M23053/8-004-C
A2B250	P110	3	M39029/58-380	M23053/8-004-C
A2B250	P113	2	M39029/58-380	M23053/8-004-C
A2B250	P113	1	M39029/58-380	M23053/8-004-C

EGPWS C/A (A2A250)

CABLE ASSY	REF-DES	PIN	CONTACT PIN	INSULATION SLEEVING
A2A250	A31P1	44	M39029/57-354	-
A2A250	A31P1	45	M39029/57-354	-
A2A250	A31P1	43	M39029/57-354	M23053/8-005-C
A2A250	A95P1	43	M39029/57-354	M23053/8-005-C
A2A250	A95P1	44	M39029/57-354	M23053/8-005-C
A2A250	J113	1	M39029/56-348	M23053/8-005-C
A2A250	J113	2	M39029/56-348	M23053/8-005-C

EGPWS C/A (B2B238)

CABLE ASSY	REF-DES	PIN	CONTACT PIN	INSULATION SLEEVING
A2B250	J110	2	M39029/56-348	M23053/8-005-C
A2B250	J110	3	M39029/56-348	M23053/8-005-C
A2B250	J208	7	M39029/56-348	M23053/8-005-C
A2B250	J208	14	M39029/56-348	M23053/8-005-C

EGPWS C/A (C2B223)

CABLE ASSY	REF-DES	PIN	CONTACT PIN	INSULATION SLEEVING
C2B223	A106P1	58	M39029/57-354	M23053/8-005-C
C2B223	A106P1	56	M39029/57-354	M23053/8-005-C
C2B223	P208	7	M39029/58-380	M23053/8-005-C
C2B223	P208	14	M39029/58-380	M23053/8-005-C

3G3440W00311
WIRING DIAGRAM EGPWS
 SHEET 3

Figure 15

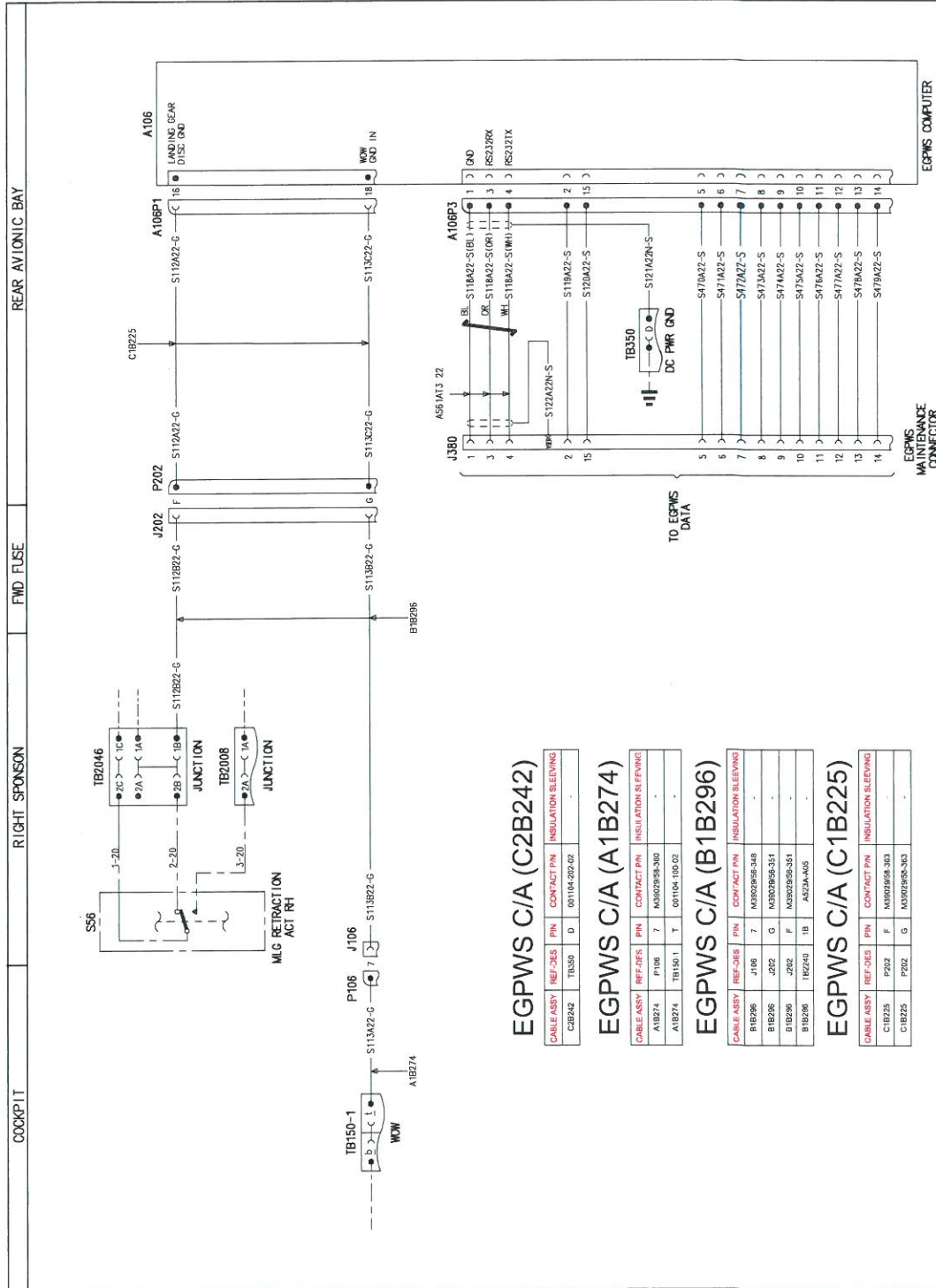

Figure 16

FUNCTIONAL NOTES
ALL CABLES ARE IN LOCK C2B242 UNLESS SPECIFIED.
ALL CABLES ARE OF TYPE ASS6AT 22 UNLESS SPECIFIED

DRILL:
HOLE Ø 11.48 ± 11.61

INSTALL:
NAS1836-3-13 INSERT (QTY 2)

APPLY:
EA934NA (C397) ADHESIVE

3G5315A49131
PANEL ASSY RH UPPER (REF)

INSTALL:
3G5315A19551 BRAKET
NAS1149D032K WASHER (QTY 2)
MS27039-1-06 SCREW (QTY 2)

SECTION H-H

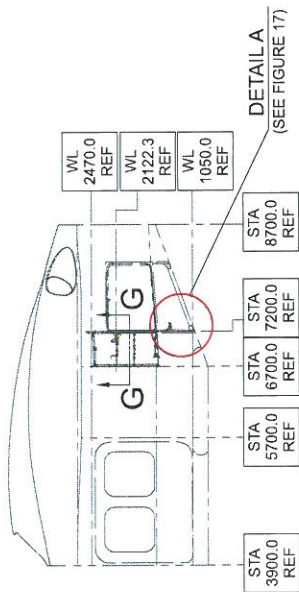

DETAIL A
(SEE FIGURE 17)

LH VIEW

STRUCTURE AND SYSTEMS ARE PARTIALLY OMITTED FOR BETTER CLARITY PURPOSE

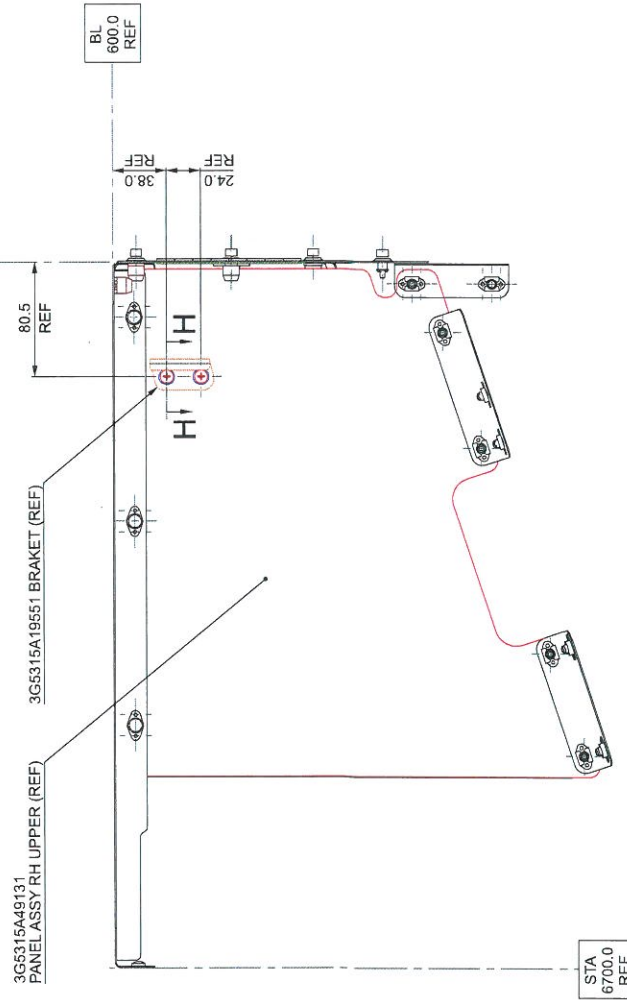

SECTION G-G

Figure 18

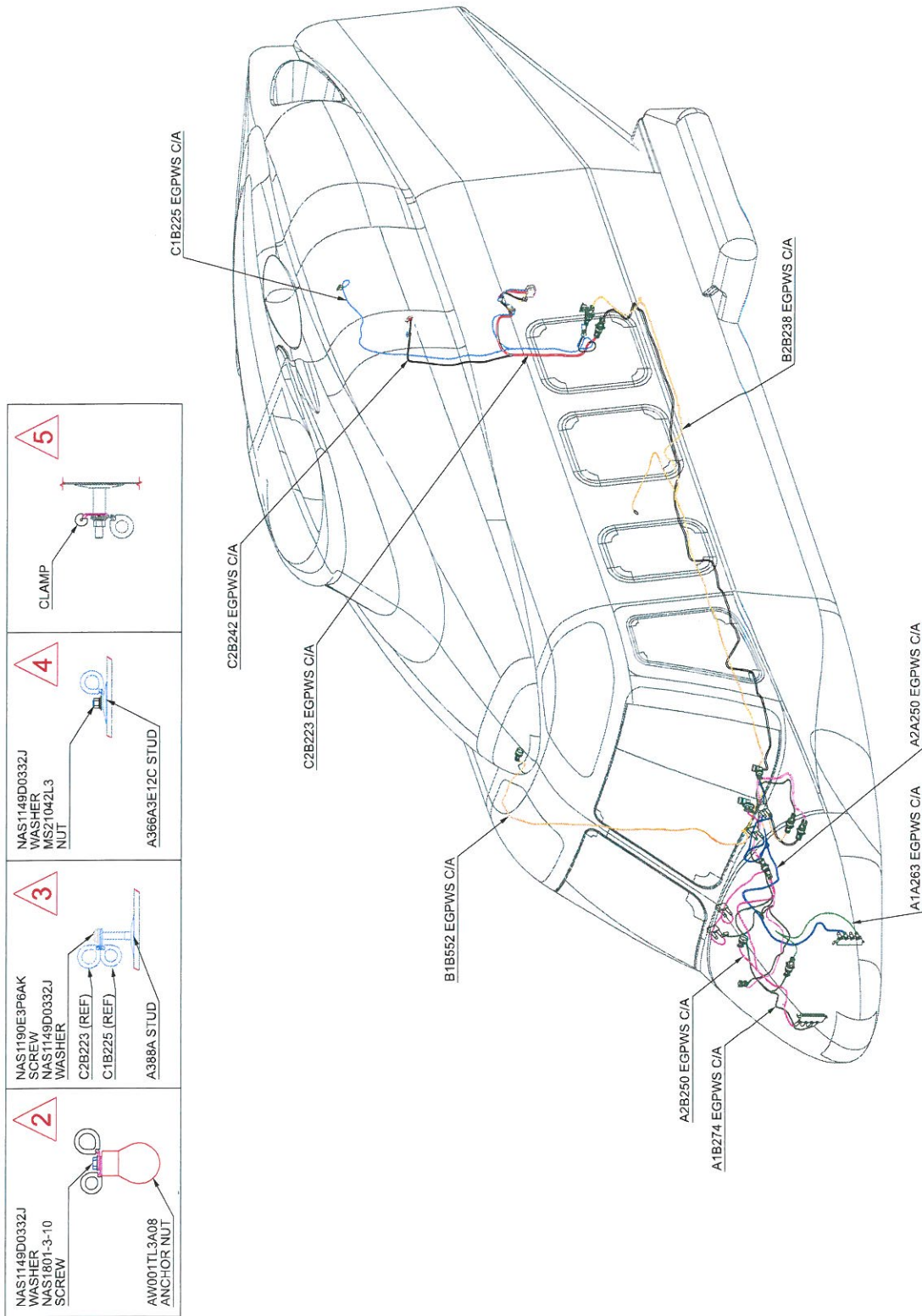

Figure 19

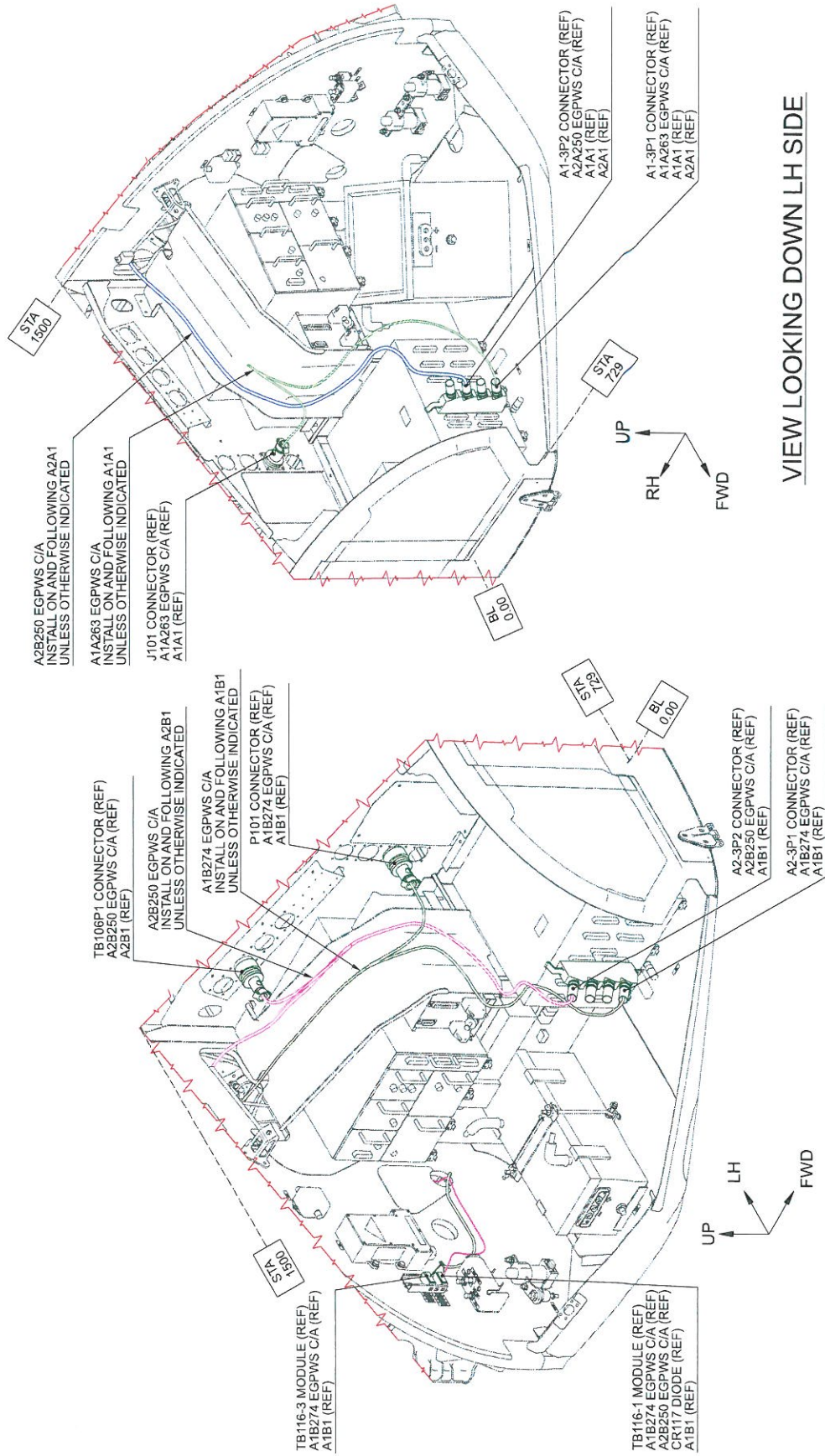
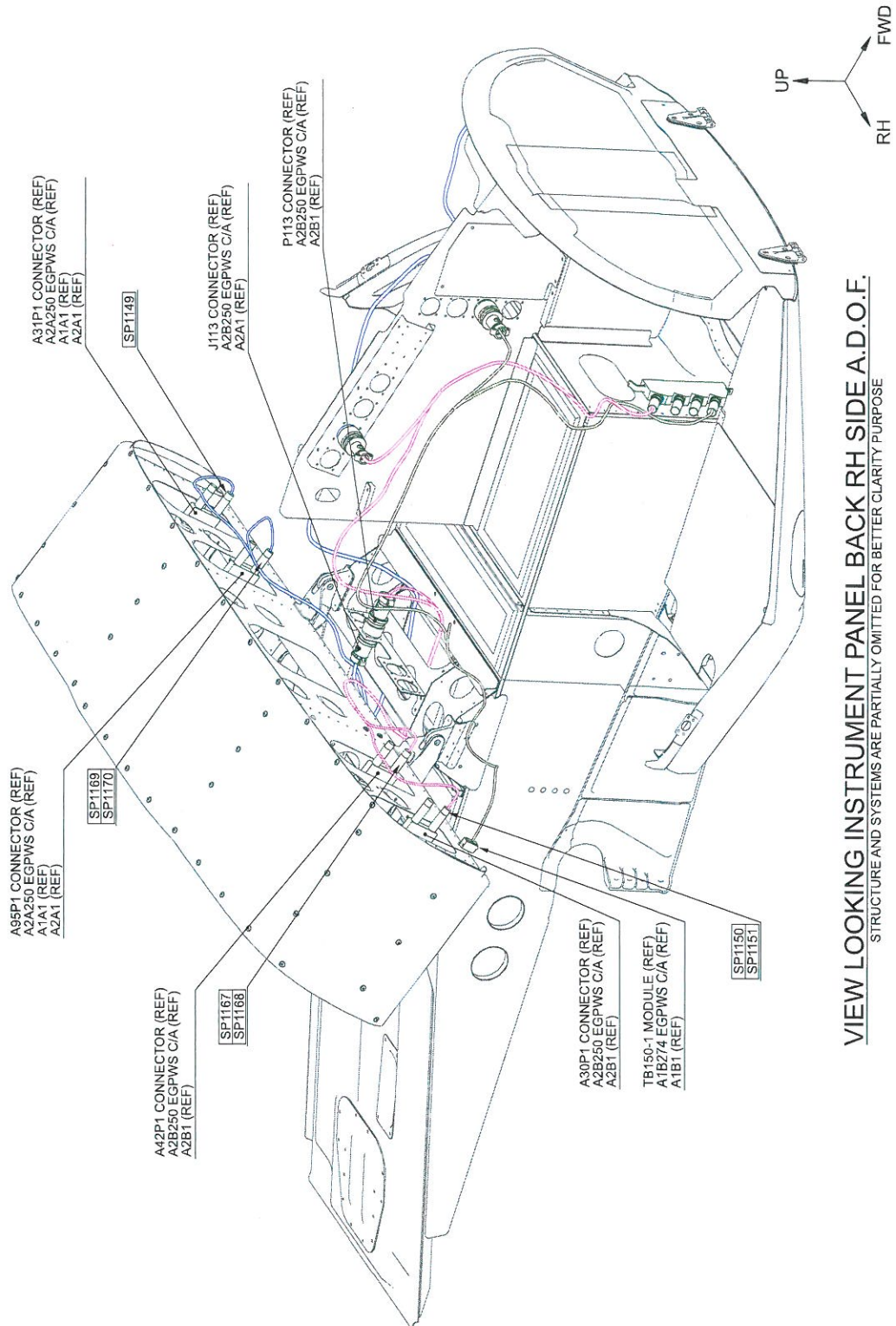

Figure 20



VIEW LOOKING INSTRUMENT PANEL BACK RH SIDE A.D.O.F.

STRUCTURE AND SYSTEMS ARE PARTIALLY OMITTED FOR BETTER CLARITY PURPOSE

Figure 21

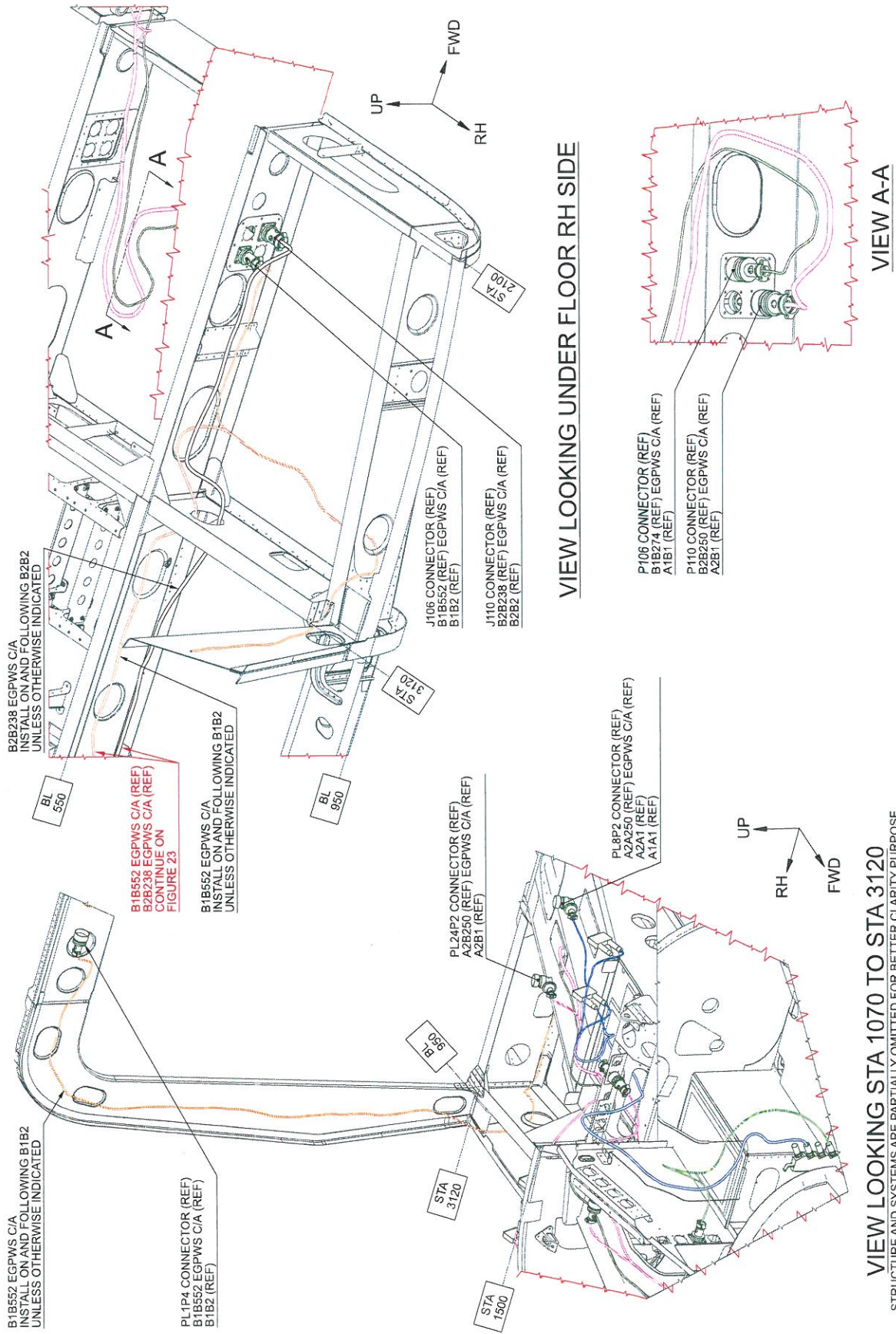
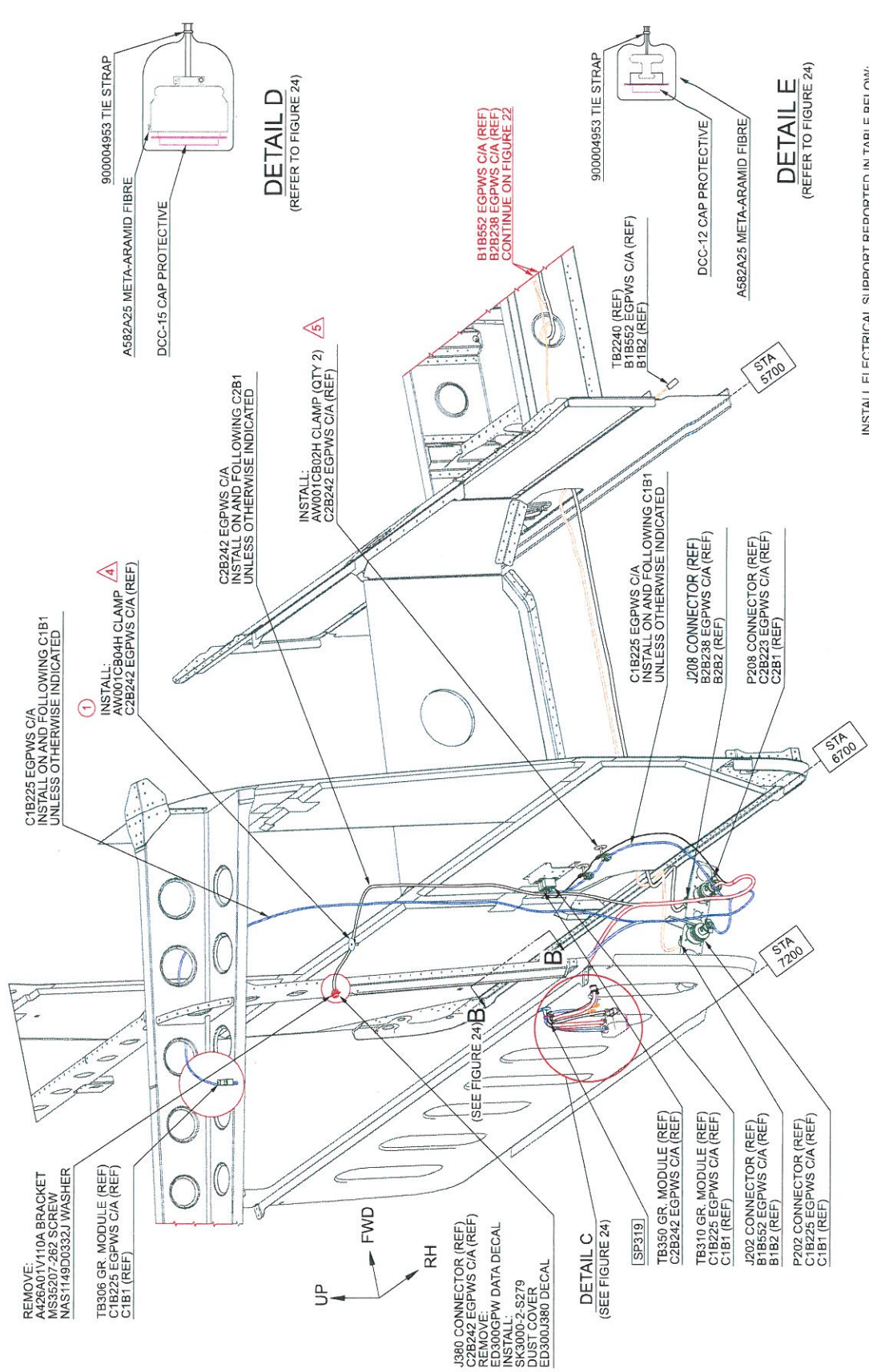

Figure 22

S.B. N°139-665
DATE: July 8, 2021
REVISION: A - May 31, 2022



INSTALL ELECTRICAL SUPPORT REPORTED IN TABLE BELOW:

LOCATION NUMBER	PART. NUMBER	STA	BL	WL	ORIENTATION
①	A366A3E12C	7058	759	2106	-

VIEW LOOKING REAR AREA RH SIDE

STRUCTURE AND SYSTEMS ARE PARTIALLY OMITTED FOR BETTER CLARITY PURPOSE

Figure 23

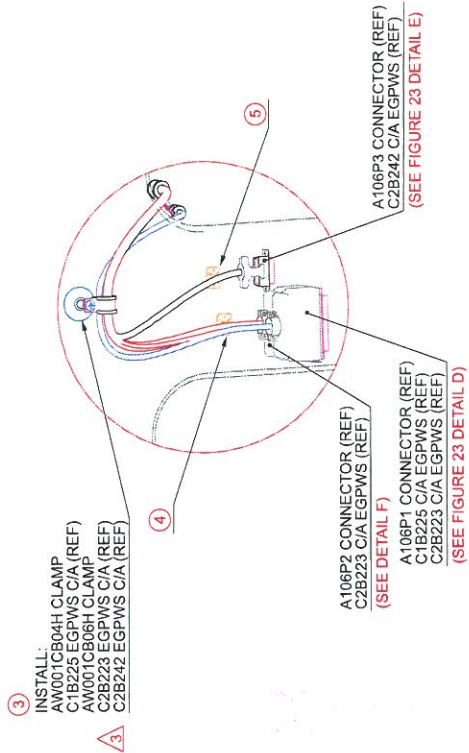

DETAIL C
(REFER TO FIGURE 23)

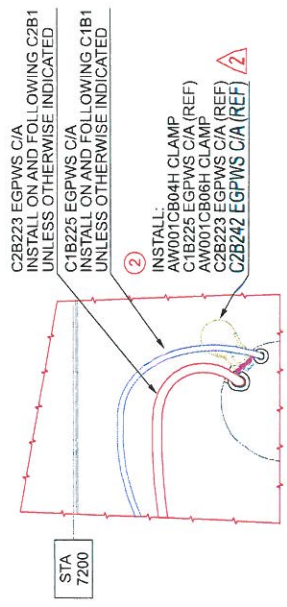

VIEW B-B
(REFER TO FIGURE 23)

INSTALL ELECTRICAL SUPPORT REPORTED IN TABLE BELOW:

LOCATION NUMBER	PART. NUMBER	STA	BL	WL	ORIENTATION
②	AW001TL3A08	7200	665	1427	135°
③	A388A3E06C	7200	601	1503	-
④	AW001CL001-N6	7200	563	1364	0°
⑤	AW001CL001-N6	7200	613	1364	0°

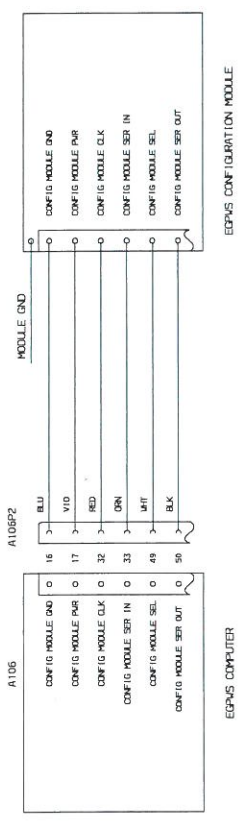

DETAIL G

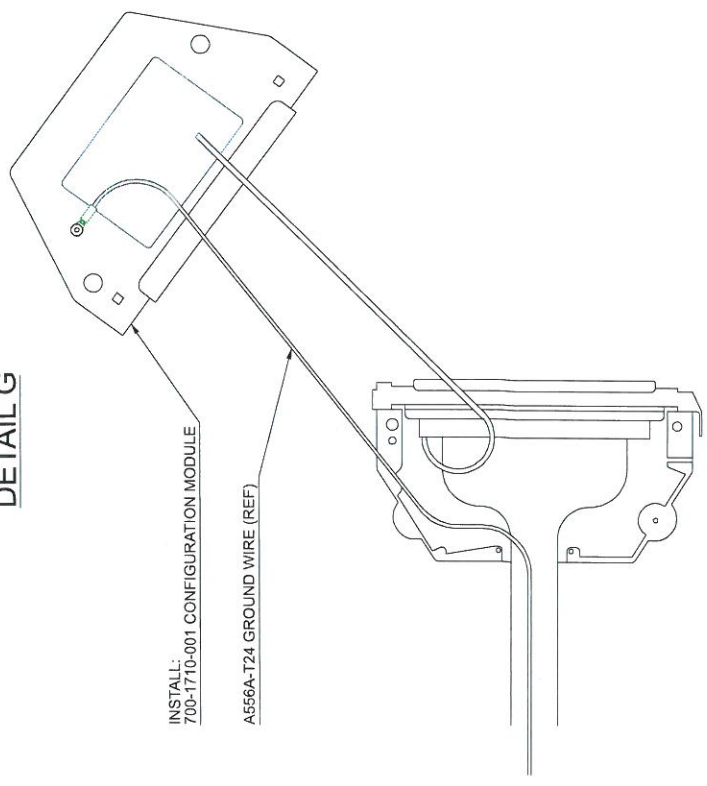

DETAIL F

STRUCTURE AND SYSTEMS ARE PARTIALLY OMITTED FOR BETTER CLARITY PURPOSE

Figure 24

DRAWING REF. KEY
△ SHEET NO. 2

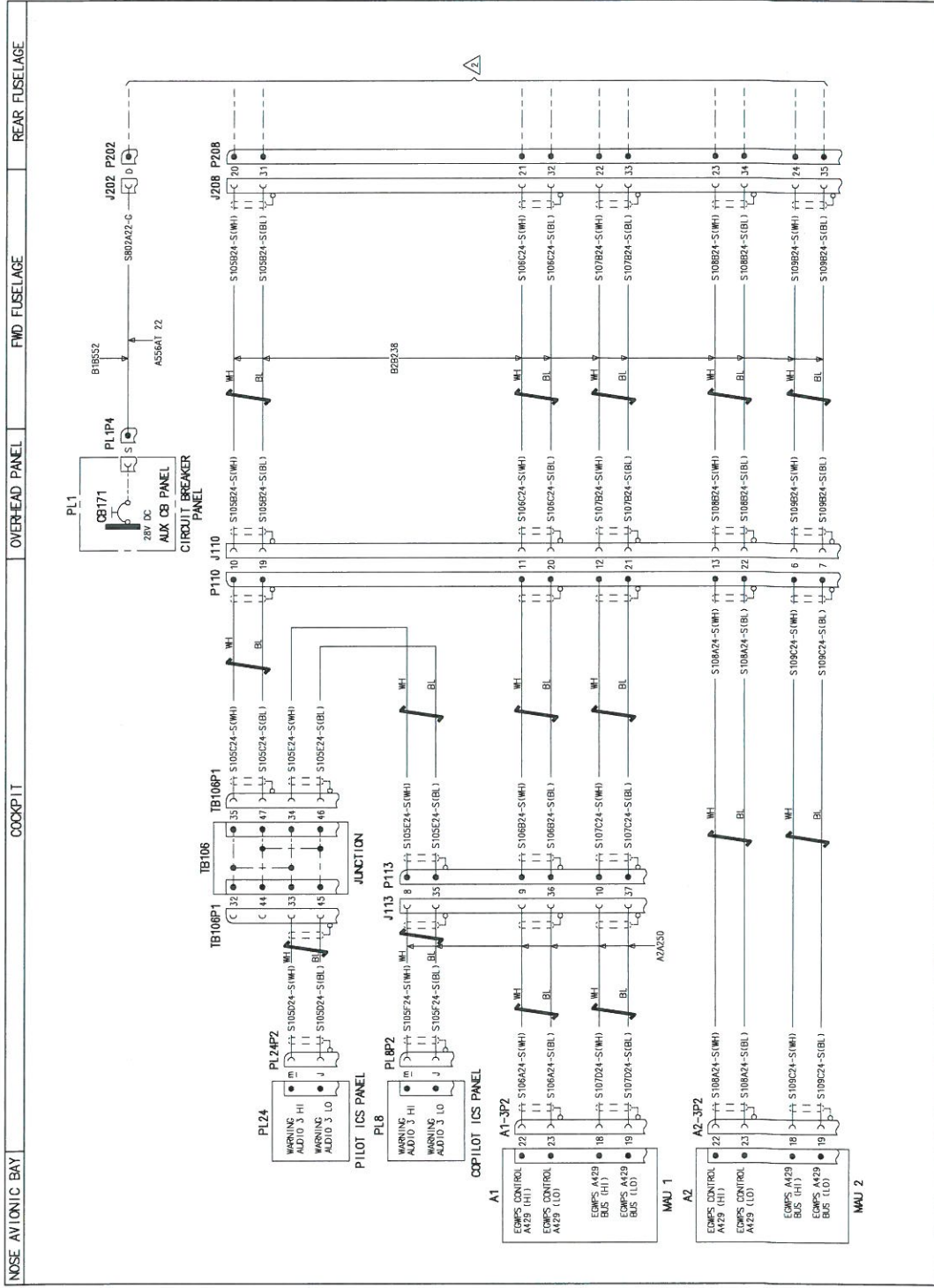

3G3440W00321
WIRING DIAGRAM EGPWS
SHEET 1

FUNCTIONAL NOTES
ALL CABLES ARE IN LOOM A2B230, UNLESS SPECIFIED.
ALL CABLES ARE OF TYPE AS6412 24 UNLESS SPECIFIED.

Figure 25

EGPWS C/A (A2B250)

CABLE ASSY	REF-DES	PIN	CONTACT P/N	INSULATION SLEEVING
A2B250	A2-3P2	22	M39029/57-354	M23053/8-004-C
A2B250	A2-3P2	23	M39029/57-354	M23053/8-004-C
A2B250	A2-3P2	18	M39029/57-354	M23053/8-004-C
A2B250	A2-3P2	19	M39029/57-354	M23053/8-004-C
A2B250	P110	13	M39029/58-360	M23053/8-004-C
A2B250	P110	22	M39029/58-360	M23053/8-004-C
A2B250	P110	6	M39029/58-360	M23053/8-004-C
A2B250	P110	7	M39029/58-360	M23053/8-004-C
A2B250	P110	11	M39029/58-360	M23053/8-004-C
A2B250	P110	20	M39029/58-360	M23053/8-004-C
A2B250	P110	12	M39029/58-360	M23053/8-004-C
A2B250	P110	21	M39029/58-360	M23053/8-004-C
A2B250	P110	10	M39029/58-360	M23053/8-004-C
A2B250	P110	19	M39029/58-360	M23053/8-004-C
A2B250	P113	8	M39029/58-360	M23053/8-004-C
A2B250	P113	36	M39029/58-360	M23053/8-004-C
A2B250	P113	10	M39029/58-360	M23053/8-004-C
A2B250	P113	37	M39029/58-360	M23053/8-004-C
A2B250	P113	8	M39029/58-360	M23053/8-004-C
A2B250	P113	35	M39029/58-360	M23053/8-004-C
A2B250	PL24P2	J	M39029/57-357	M23053/8-004-C
A2B250	PL24P2	M	M39029/57-357	M23053/8-004-C
A2B250	TB106P1	45	M39029/56-348	M23053/8-004-C
A2B250	TB106P1	33	M39029/56-348	M23053/8-004-C
A2B250	TB106P1	35	M39029/56-348	M23053/8-004-C
A2B250	TB106P1	47	M39029/56-348	M23053/8-004-C
A2B250	TB106P1	34	M39029/56-348	M23053/8-004-C
A2B250	TB106P1	46	M39029/56-348	M23053/8-004-C

EGPWS C/A (A2A250)

CABLE ASSY	REF-DES	PIN	CONTACT P/N	INSULATION SLEEVING
A2A250	A1-3P2	22	M39029/57-354	M23053/8-004-C
A2A250	A1-3P2	23	M39029/57-354	M23053/8-004-C
A2A250	A1-3P2	18	M39029/57-354	M23053/8-004-C
A2A250	A1-3P2	19	M39029/57-354	M23053/8-004-C
A2A250	PL8P2	M	M39029/57-357	M23053/8-004-C
A2A250	PL8P2	J	M39029/57-357	M23053/8-004-C
A2A250	J113	8	M39029/56-348	M23053/8-004-C
A2A250	J113	35	M39029/56-348	M23053/8-004-C
A2A250	J113	9	M39029/56-348	M23053/8-004-C
A2A250	J113	36	M39029/56-348	M23053/8-004-C
A2A250	J113	10	M39029/56-348	M23053/8-004-C
A2A250	J113	37	M39029/56-348	M23053/8-004-C

EGPWS C/A (B2B238)

CABLE ASSY	REF-DES	PIN	CONTACT P/N	INSULATION SLEEVING
B2B238	J110	10	M39029/56-348	M23053/8-004-C
B2B238	J110	19	M39029/56-348	M23053/8-004-C
B2B238	J110	11	M39029/56-348	M23053/8-004-C
B2B238	J110	20	M39029/56-348	M23053/8-004-C
B2B238	J110	12	M39029/56-348	M23053/8-004-C
B2B238	J110	21	M39029/56-348	M23053/8-004-C
B2B238	J110	13	M39029/56-348	M23053/8-004-C
B2B238	J110	22	M39029/56-348	M23053/8-004-C
B2B238	J110	6	M39029/56-348	M23053/8-004-C
B2B238	J110	7	M39029/56-348	M23053/8-004-C
B2B238	J206	20	M39029/56-348	M23053/8-004-C
B2B238	J206	31	M39029/56-348	M23053/8-004-C
B2B238	J206	21	M39029/56-348	M23053/8-004-C
B2B238	J206	32	M39029/56-348	M23053/8-004-C
B2B238	J206	22	M39029/56-348	M23053/8-004-C
B2B238	J206	33	M39029/56-348	M23053/8-004-C
B2B238	J206	23	M39029/56-348	M23053/8-004-C
B2B238	J206	34	M39029/56-348	M23053/8-004-C
B2B238	J206	24	M39029/56-348	M23053/8-004-C
B2B238	J206	35	M39029/56-348	M23053/8-004-C

EGPWS C/A (B1B552)

CABLE ASSY	REF-DES	PIN	CONTACT P/N	INSULATION SLEEVING
B1B552	J202	D	M39029/56-351	
B1B552	PL1P4	S	M39029/56-363	

Figure 26

DRAWING REF. KEY
△ SHEET NO. 1

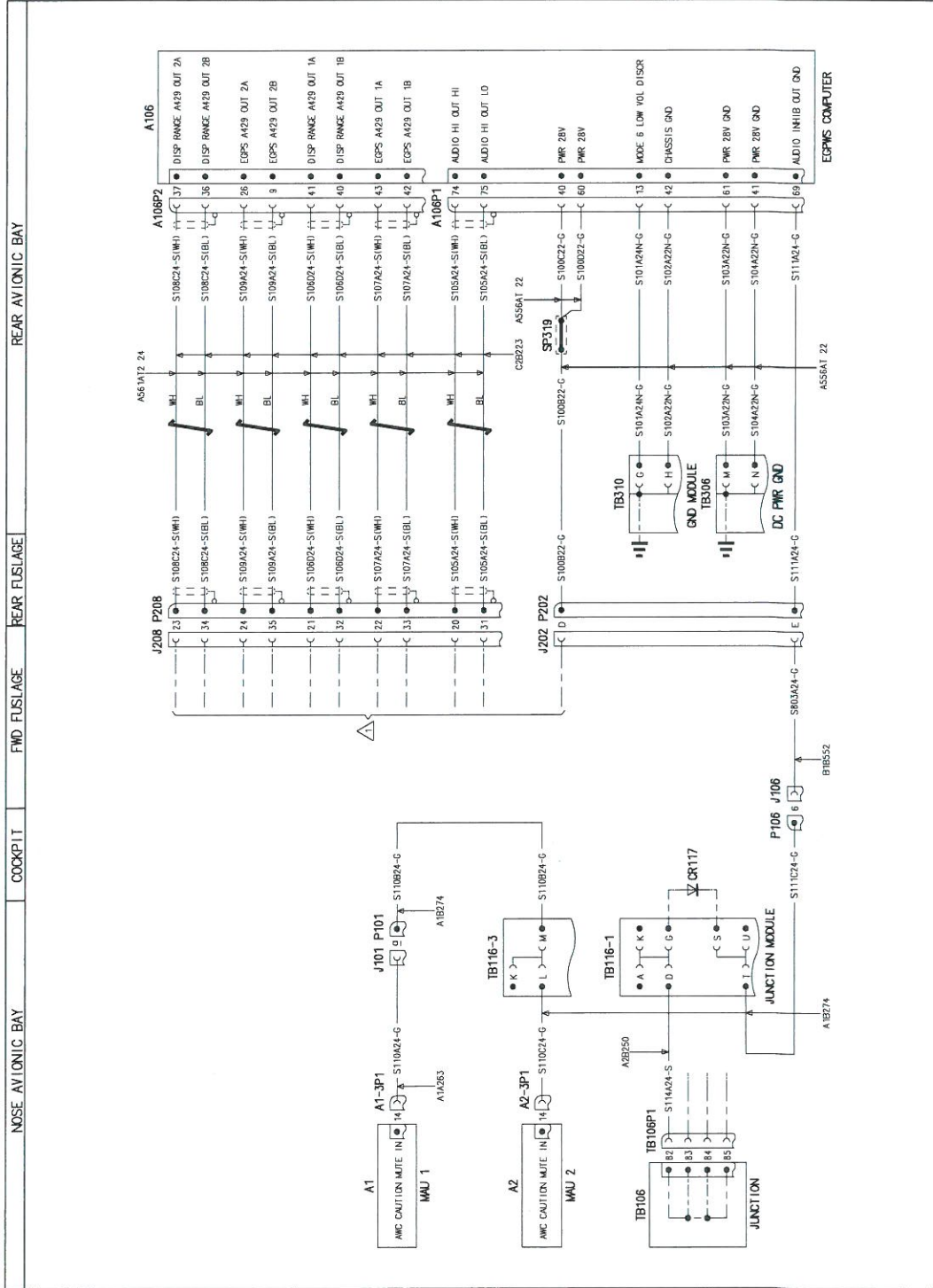

3G3440W00321
WIRING DIAGRAM EGPWS
SHEET 2

FUNCTIONAL NOTES
ALL CABLES ARE IN LOOM CIB225 UNLESS SPECIFIED
ALL CABLES ARE OF TYPE ASS6AT 24 UNLESS SPECIFIED

Figure 27

EGPWS C/A (C1B225)

CABLE ASSY	REF-DES	PIN	CONTACT P/N	INSULATION SLEEVING
C1B225	P202	D	M39029/58-363	-
C1B225	P202	E	M39029/58-363	-
C1B225	TB306	N	001104-202-02	-
C1B225	TB306	M	001104-202-02	-
C1B225	TB310	G	001104-202-02	-
C1B225	TB310	H	001104-202-02	-

EGPWS C/A (B1B552)

CABLE ASSY	REF-DES	PIN	CONTACT P/N	INSULATION SLEEVING
B1B552	J106	6	M39029/56-348	-
B1B552	J202	E	M39029/56-351	-

EGPWS C/A (A2B250)

CABLE ASSY	REF-DES	PIN	CONTACT P/N	INSULATION SLEEVING
A2B250	TB106P1	B2	M39029/56-348	M23053/8-004-C
A2B250	TB116-1	D	001104-202-02	-

EGPWS C/A (A1B274)

CABLE ASSY	REF-DES	PIN	CONTACT P/N	INSULATION SLEEVING
A1B274	A2-3P1	14	M39029/57-354	-
A1B274	P101	A	M39029/58-363	-
A1B274	P106	6	M39029/58-360	-
A1B274	TB116-1	T	001104-202-02	-
A1B274	TB116-3	L	001104-202-02	-
A1B274	TB116-3	M	001104-202-02	-

EGPWS C/A (C2B223)

CABLE ASSY	REF-DES	PIN	CONTACT P/N	INSULATION SLEEVING
C2B223	A108P1	74	M39029/57-354	M23053/8-004-C
C2B223	A108P1	75	M39029/57-354	M23053/8-004-C
C2B223	P208	20	M39029/58-360	M23053/8-004-C
C2B223	P208	31	M39029/58-360	M23053/8-004-C
C2B223	P208	21	M39029/58-360	M23053/8-004-C
C2B223	P208	32	M39029/58-360	M23053/8-004-C
C2B223	P208	22	M39029/58-360	M23053/8-004-C
C2B223	P208	33	M39029/58-360	M23053/8-004-C
C2B223	P208	23	M39029/58-360	M23053/8-004-C
C2B223	P208	34	M39029/58-360	M23053/8-004-C
C2B223	P208	24	M39029/58-360	M23053/8-004-C
C2B223	P208	35	M39029/58-360	M23053/8-004-C

EGPWS C/A (A1A263)

CABLE ASSY	REF-DES	PIN	CONTACT P/N	INSULATION SLEEVING
A1A263	A1-3P1	14	M39029/57-354	-
A1A263	J101	A	M39029/56-351	-

3G3440W00321
 WIRING DIAGRAM EGPWS
 SHEET 2

Figure 28

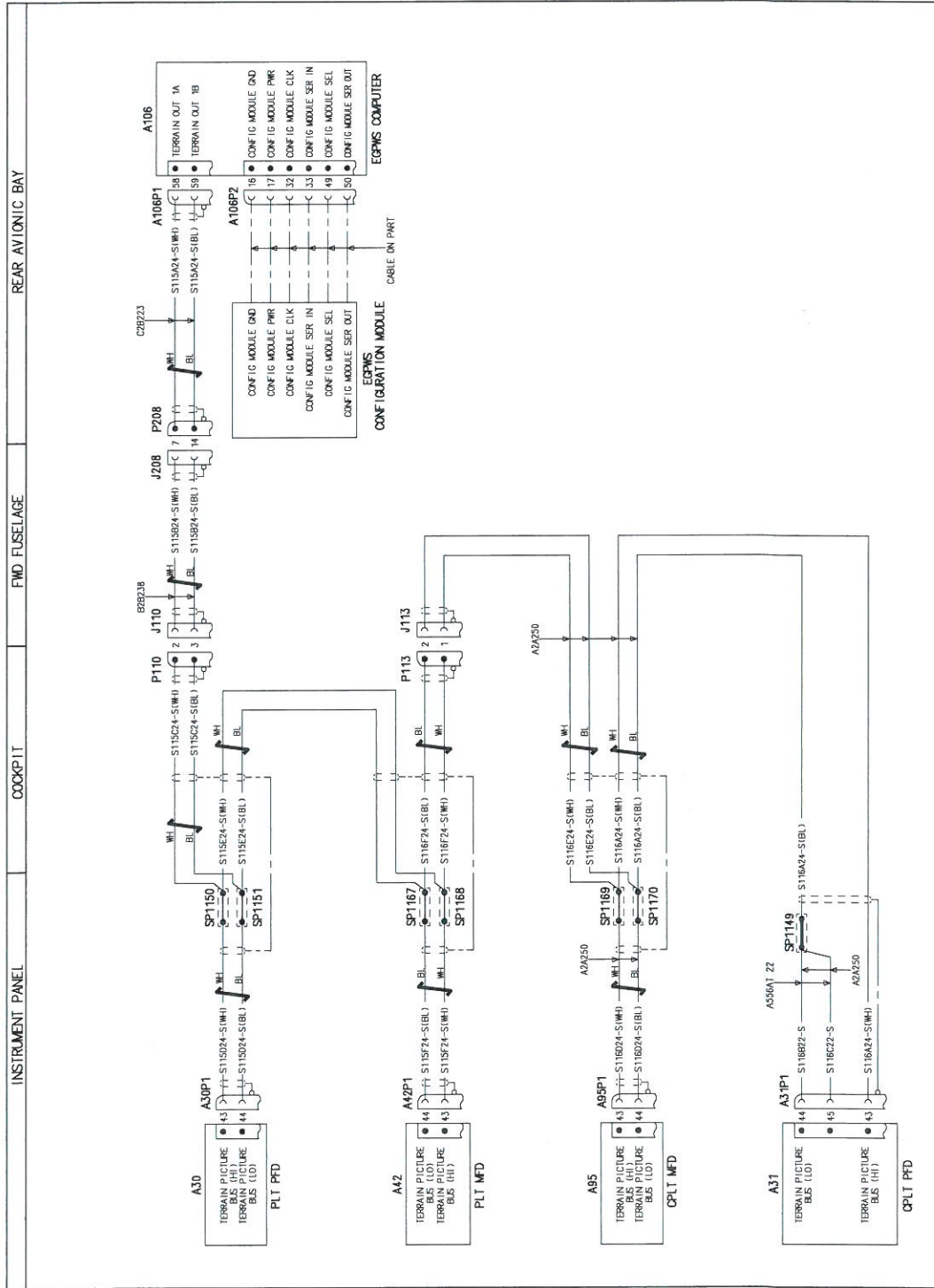

FUNCTIONAL NOTES
ALL CABLES ARE IN LOOM A2B250 UNLESS SPECIFIED
ALL CABLES ARE OF TYPE M17-776-0000 UNLESS SPECIFIED

Figure 29

EGPWS C/A (A2B250)

CABLE ASSY	REF-DES	PIN	CONTACT P/N	INSULATION SLEEVING
A2B250	A30P1	43	M39029/57-354	M23053/8-005-C
A2B250	A30P1	44	M39029/57-354	M23053/8-005-C
A2B250	A42P1	44	M39029/57-354	M23053/8-005-C
A2B250	A42P1	43	M39029/57-354	M23053/8-005-C
A2B250	P110	2	M39029/58-360	M23053/8-004-C
A2B250	P110	3	M39029/58-360	M23053/8-004-C
A2B250	P113	2	M39029/58-360	M23053/8-005-C
A2B250	P113	1	M39029/58-360	M23053/8-005-C

EGPWS C/A (A2A250)

CABLE ASSY	REF-DES	PIN	CONTACT P/N	INSULATION SLEEVING
A2A250	A31P1	44	M39029/57-354	-
A2A250	A31P1	45	M39029/57-354	-
A2A250	A31P1	43	M39029/57-354	M23053/8-005-C
A2A250	A95P1	43	M39029/57-354	M23053/8-005-C
A2A250	A06P1	44	M39029/57-354	M23053/8-005-C
A2A250	J113	1	M39029/56-348	M23053/8-005-C
A2A250	J113	2	M39029/56-348	M23053/8-005-C

EGPWS C/A (B2B238)

CABLE ASSY	REF-DES	PIN	CONTACT P/N	INSULATION SLEEVING
A2B250	J110	2	M39029/56-348	M23053/8-005-C
A2B250	J110	3	M39029/56-348	M23053/8-005-C
A2B250	J208	7	M39029/56-348	M23053/8-005-C
A2B250	J208	14	M39029/56-348	M23053/8-005-C

EGPWS C/A (C2B223)

CABLE ASSY	REF-DES	PIN	CONTACT P/N	INSULATION SLEEVING
C2B223	A109P1	58	M39029/57-354	M23053/8-005-C
C2B223	A109P1	59	M39029/57-354	M23053/8-005-C
C2B223	P208	7	M39029/58-360	M23053/8-005-C
C2B223	P208	14	M39029/58-360	M23053/8-005-C

3G3440W00321
 WIRING DIAGRAM EGPWS
 SHEET 3

Figure 30

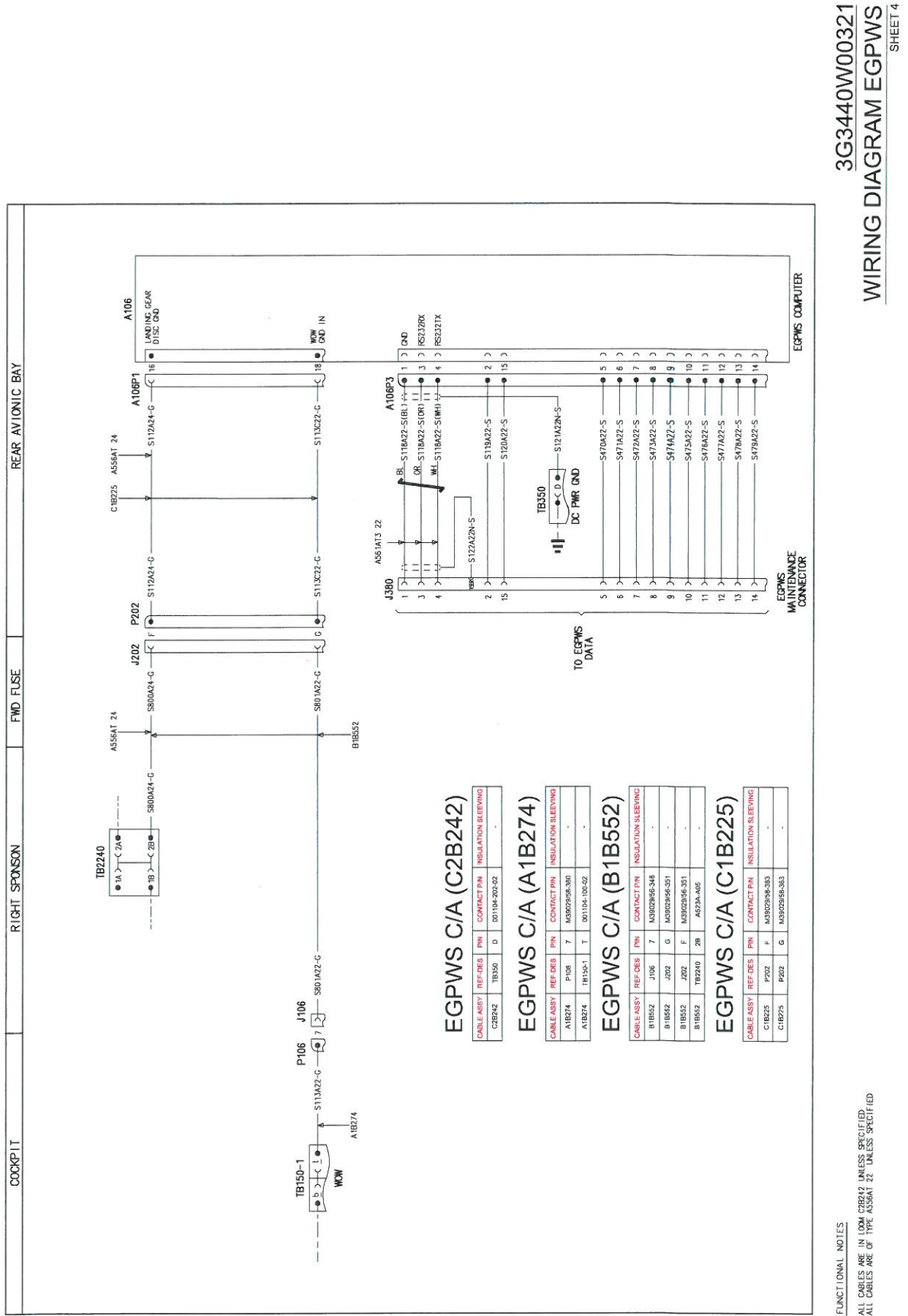

3G3440W00321
WIRING DIAGRAM EGPWS
SHEET 4

EGPWS C/A (C2B242)

CABLE ASSY	REF DES	PN	CONTACT P/N	INSULATION SLEEVING
C2B242	TB350	D	001104-202-02	-

EGPWS C/A (A1B274)

CABLE ASSY	REF DES	PN	CONTACT P/N	INSULATION SLEEVING
A1B274	P106	T	M382098-300	-
A1B274	TB150-1	T	001104-100-02	-

EGPWS C/A (B1B552)

CABLE ASSY	REF DES	PN	CONTACT P/N	INSULATION SLEEVING
B1B52	J106	7	M382096-348	-
B1B52	J202	G	M382096-351	-
B1B52	J202	F	M382096-351	-
B1B52	TB220	ZH	A23A-A05	-

EGPWS C/A (C1B225)

CABLE ASSY	REF DES	PN	CONTACT P/N	INSULATION SLEEVING
C1B225	P202	F	M382098-383	-
C1B225	P202	G	M382096-383	-

FUNCTIONAL NOTES
ALL CABLES ARE IN LDM C2B242 UNLESS SPECIFIED
ALL CABLES ARE OF TYPE ASS6AT 22 UNLESS SPECIFIED

Figure 31

S.B. N°139-665
DATE: July 8, 2021
REVISION: A May 31, 2022

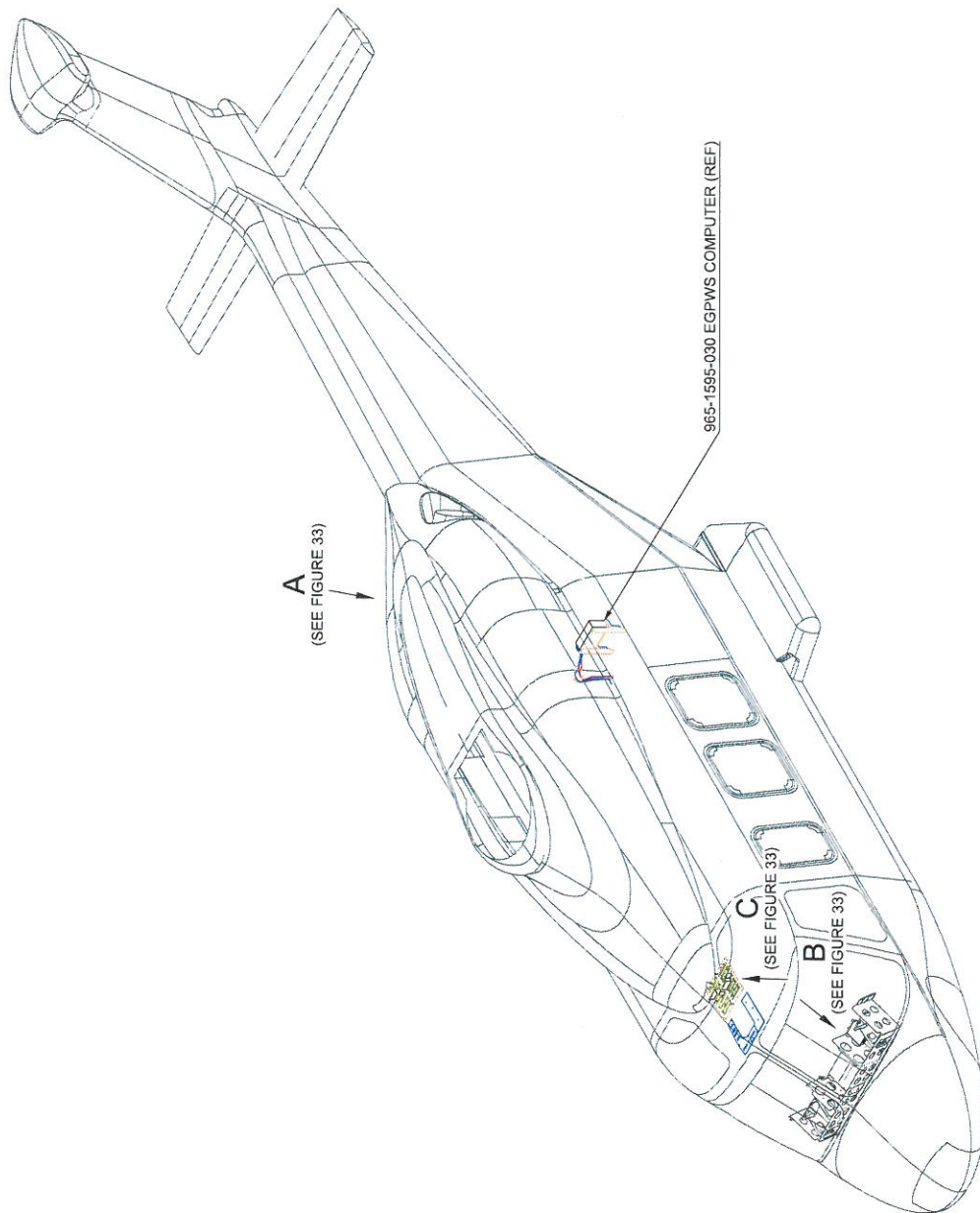

Figure 32

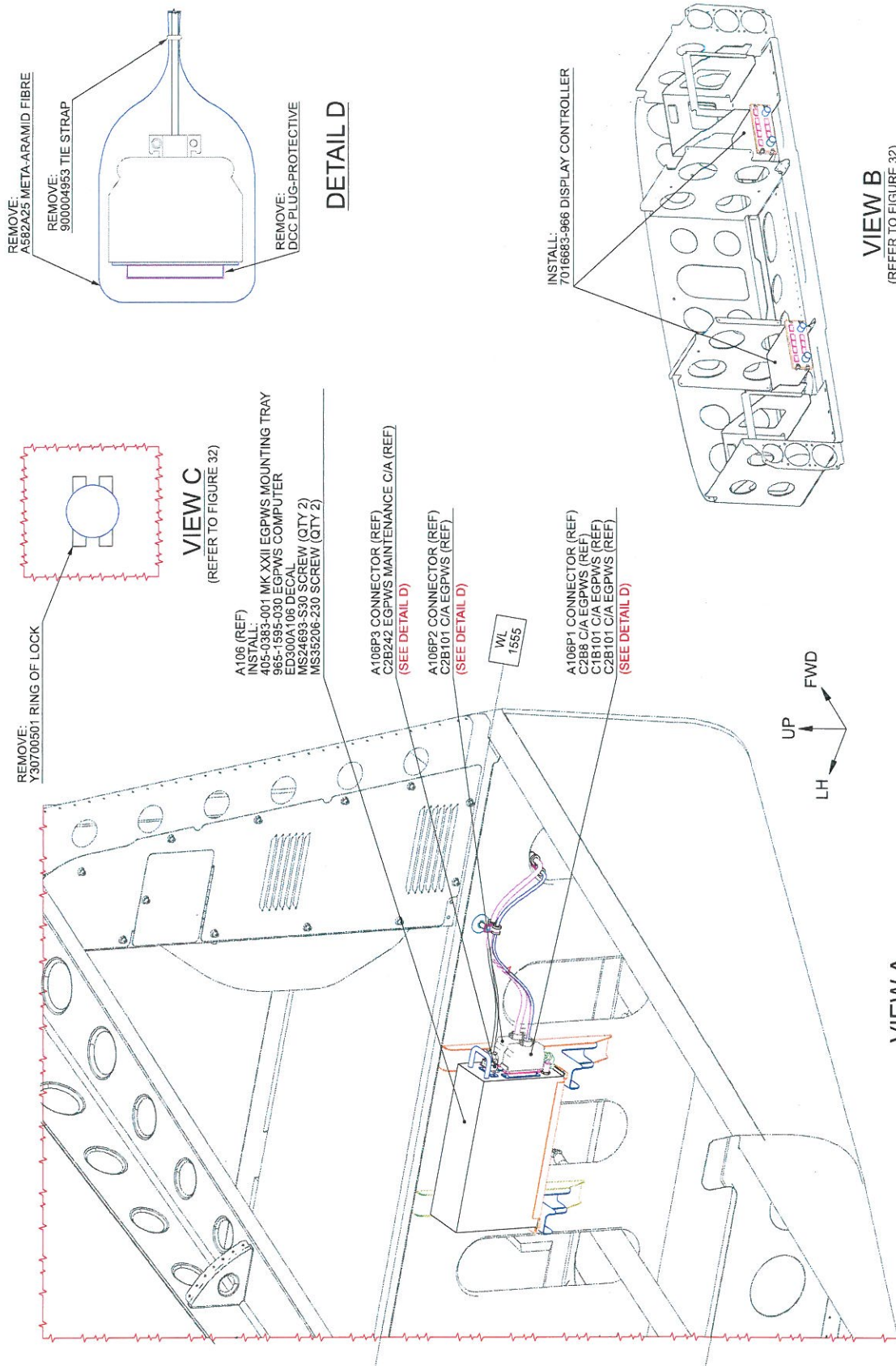

Figure 33

Please send to the following address: LEONARDO S.p.A. CUSTOMER SUPPORT & SERVICES - ITALY PRODUCT SUPPORT ENGINEERING & LICENSES DEPT. Via Giovanni Agusta, 520 21017 Cascina Costa di Samarate (VA) - ITALY Tel.: +39 0331 225036 Fax: +39 0331 225988		SERVICE BULLETIN COMPLIANCE FORM		Date:	
		Number:			
		Revision:			
Customer Name and Address:			Telephone:		
			Fax:		
			B.T. Compliance Date:		
Helicopter Model	S/N	Total Number	Total Hours	T.S.O.	
Remarks:					
Information: We request your cooperation in filling this form, in order to keep out statistical data relevant to aircraft configuration up-to-date. The form should be filled in all its parts and sent to the above address or you can communicate the application also via Technical Bulletin Application Communication Section placed in Leonardo AW Customer Portal - MyCommunications Area. We thank you beforehand for the information given.					