



LEONARDO MALAYSIA SDN.BHD.

WORK CARD

SERVICE ORDER NUMBER:

90025566

WORKCARD NUMBER:

2023/BGH/001-06

TITLE:

SB 139-624 DATE: MARCH 18, 2022 REV.: / - ATA 23 – SATCOM SKYTRACK ISAT-200A KIT INSTALLATION (PART II)

CUSTOMER:

LEONARDO HELICOPTER ITALY (LHI)

REGISTRATION:

9M-BGH

AIRFRAME HOURS:

302:40

#1 ENGINE

SERIAL NUMBER:

PCE-KB1931

#2 ENGINE

SERIAL NUMBER:

PCE-KB1885

APU

SERIAL NUMBER:

N/A

SERIAL NUMBER:

31763

LANDINGS:

850

HOURS:

302:40

HOURS:

302:40

HOURS:

N/A

NO	SOURCE	TASK / REFERENCE	REMARKS	MECHANIC SIGN	* AH SIGN & STAMP	DATE
----	--------	------------------	---------	---------------	-------------------	------



ACCOMPLISHMENT INSTRUCTIONS

GENERAL NOTES

- A) PLACE AN IDENTIFICATION TAG ON ALL COMPONENTS THAT ARE RE-USABLE, INCLUDING THE ATTACHING HARDWARE THAT HAS BEEN REMOVED TO GAIN ACCESS TO THE MODIFICATION AREA AND ADEQUATELY PROTECT THEM UNTIL THEIR LATER REUSE.
- B) EXERCISE EXTREME CARE DURING DRILLING OPERATIONS TO PREVENT INSTRUMENTS, CABLES AND HOSES DAMAGE.
- C) AFTER DRILLING, REMOVE ALL SWarf AND SHARP EDGES. APPLY ON BARE METAL A LIGHT FILM OF PRIMER UNLESS THE HOLE IS USED FOR GROUND CONNECTION.
- D) SHAPE THE CABLES IN ORDER TO PREVENT INTERFERENCE WITH THE STRUCTURE AND THE OTHER EXISTING INSTALLATIONS, USING WHERE NECESSARY SUITABLE LACING CORDS.
- E) DURING THE INSTALLATION OF BONDING BRAIDS OR COMPONENTS REQUIRING GROUNDING, CLEAN THE SURFACE STRUCTURE IN ORDER TO OBTAIN A GOOD GROUND CONTACT.
- F) PROTECT PROPERLY ALL THOSE EQUIPMENT NOT REMOVED FROM AREA AFFECTED BY THE MODIFICATION DURING INSTALLATION PROCEDURE.
- G) LET THE ADHESIVE CURE AT ROOM TEMPERATURE FOR AT LEAST 24 HOURS, UNLESS OTHERWISE SPECIFIED.
- H) ALL LENGTHS ARE IN MM.

<input type="checkbox"/> PARTS / MATERIAL USED / COMPONENT CHANGE RECORD HAVE BEEN RAISED AND ATTACHED.	<input type="checkbox"/> CALIBRATED / SPECIAL TOOLS RECORD SHEET HAVE BEEN RAISED AND ATTACHED.
---	---







* APPROVAL HOLDER HAVE VERIFIED THAT ALL TOOLS, EQUIPMENT AND OTHER EXTRANEIOUS PART OF MATERIALS ARE CLEARED AND ALL TASKS OR INSPECTIONS HAVE BEEN CARRIED OUT TO THE REQUIRED STANDARD. TASK HAS BEEN PERFORMED I.A.W MAINTENANCE MANUAL SPECIFIED IN WORKPACK INDEX LM/QA/GEN/01.

NO	SOURCE	TASK / REFERENCE	REMARKS	MECHANIC SIGN	* AH SIGN & STAMP	DATE
1	-	IN ACCORDANCE WITH AMP DM 39-A-00-20-00-00A-120A-A PREPARE THE HELICOPTER ON GROUND FOR A SAFE MAINTENANCE. DISCONNECT THE BATTERY, ALL ELECTRICAL POWER SOURCES AND/OR THE EXTERNAL POWER SUPPLY.	SATISFACTORY DISCONNECTED	adl	 adl	14/2/23
2	-	<p>NOTE</p> <p>IF NECESSARY, IN ORDER TO ENSURE A PROPER INSTALLATION OF THE EQUIPMENT, IT IS POSSIBLE TO USE BOLTS (LENGTH ONLY) AND/OR SCREWS (LENGTH ONLY) AND/OR SPACERS (LENGTH ONLY) AND/OR WASHERS (THICKNESS ONLY) OF TWO INCREMENTS GREATER OR LESSER WITH RESPECT TO THE INDICATED ONES.</p> <p>IN ACCORDANCE WITH AMP DM 39-A-06-41-00-00A-010A-A AND WITH REFERENCE TO FIGURE 12, GAIN ACCESS TO THE AREA AFFECTED BY THE INSTALLATION AND PERFORM THE SATCOM ISAT-200A EQUIPMENT INSTALLATION P/N 3G2310A13611 AS DESCRIBED IN THE FOLLOWING PROCEDURE:</p> <p>2.1 WITH REFERENCE TO FIGURE 13 VIEW A, REMOVE THE PANEL P/N 999-0500-85-231 FROM THE INTERSEAT CONSOLE.</p>	SATISFACTORY REMOVED	adl	 adl	14/2/23
		<p>NOTE</p> <p>PERFORM THE FOLLOWING STEP 2.2 ONLY IF PART II OF THIS SERVICE BULLETIN IS NOT PERFORMED IMMEDIATELY AFTER PART I. OTHERWISE SKIP AT STEP 2.3</p> <p>2.2 WITH REFERENCE TO FIGURE 13 VIEW A AND DETAIL D, REMOVE THE TIE STRAPS, THE NOMEX FIBRE SLEEVES AND THE PROTECTIVE CAPS FROM THE CONNECTORS PL145P1 AND PL144P1.</p>	n/a PART II COMMENCE IMMEDIATELY	n/a	adl 	14/2/23



PARTS / MATERIAL USED / COMPONENT CHANGE RECORD HAVE BEEN RAISED AND ATTACHED. CALIBRATED / SPECIAL TOOLS RECORD SHEET HAVE BEEN RAISED AND ATTACHED.



* APPROVAL HOLDER HAVE VERIFIED THAT ALL TOOLS, EQUIPMENT AND OTHER EXTRANEIOUS PART OF MATERIALS ARE CLEARED AND ALL TASKS OR INSPECTIONS HAVE BEEN CARRIED OUT TO THE REQUIRED STANDARD. TASK HAS BEEN PERFORMED I.A.W MAINTENANCE MANUAL SPECIFIED IN WORKPACK INDEX LM/QA/GEN/01.

NO	SOURCE	TASK / REFERENCE	REMARKS	MECHANIC SIGN	* AH SIGN & STAMP	DATE
		2.3 IN ACCORDANCE WITH AMP DM 39-B-23-95-01-00A-720A-K AND WITH REFERENCE TO FIGURE 13 VIEW A, INSTALL THE COCKPIT DISPLAY PANEL CDP-300C P/N 104-300-02 IN THE INTERSEAT CONSOLE.	SATISFACTORY INSTALLED	HR	HR 	8/3/23
		2.4 IN ACCORDANCE WITH AMP DM 39-B-23-95-02-00A-720A-K AND WITH REFERENCE TO FIGURE 13 VIEW A, INSTALL THE DISPATCH VOICE INTERFACE DVI-300A P/N 105-300-02 IN THE INTERSEAT CONSOLE.	SATISFACTORY INSTALLED	HR	HR 	8/3/23
		2.5 IN ACCORDANCE WITH AMP DM 39-A-11-00-01-00A-720A-A AND WITH REFERENCE TO FIGURE 13 VIEW A, APPLY THE DECAL P/N ED300PL145 ON THE COCKPIT DISPLAY PANEL CDP-300C P/N 104-300-02 AND THE DECAL P/N ED300PL144 ON THE DISPATCH VOICE INTERFACE DVI-300A P/N 105-300-02.	SATISFACTORY APPLIED	HR	HR 	8/3/23
		2.6 IN ACCORDANCE WITH THE APPLICABLE STEPS OF AMP DM 39-B-23-95-03-00A-720A-K AND WITH REFERENCE TO FIGURE 13 VIEW B AND VIEW E, INSTALL THE TRANSCEIVER ISAT-200A P/N 101-200-07 AND THE GROUND CABLE P/N MS25083-2BB8 ON THE TRAY.	SATISFACTORY INSTALLED	HR	HR 	8/3/23
		2.7 IN ACCORDANCE WITH AMP DM 39-A-11-00-01-00A-720A-A AND WITH REFERENCE TO FIGURE 13 VIEW B, APPLY THE DECAL P/N ED300A433 ON THE TRANSCEIVER ISAT-200A.	SATISFACTORY APPLIED	HR	HR 	8/3/23
		<p align="center">NOTE</p> <p>PERFORM THE FOLLOWING STEP 2.8 ONLY IF PART II OF THIS SERVICE BULLETIN IS NOT PERFORMED IMMEDIATELY AFTER PART I. OTHERWISE SKIP AT STEP 2.9.</p> <p>2.8 WITH REFERENCE TO FIGURE 12 VIEW C, REMOVE THE COVER P/N 3G5315A61731 FROM THE SUPPORT ASSY P/N 3G5315A61632. RETAIN THE HARDWARE FOR LATER REUSE.</p>	<p align="center">N/A PART 2 COMMENCE IMMEDIATELY</p>	N/A	<p align="center">N/A</p> 	22/2/23

PARTS / MATERIAL USED / COMPONENT CHANGE RECORD HAVE BEEN RAISED AND ATTACHED.

CALIBRATED / SPECIAL TOOLS RECORD SHEET HAVE BEEN RAISED AND ATTACHED.









* APPROVAL HOLDER HAVE VERIFIED THAT ALL TOOLS, EQUIPMENT AND OTHER EXTRANEIOUS PART OF MATERIALS ARE CLEARED AND ALL TASKS OR INSPECTIONS HAVE BEEN CARRIED OUT TO THE REQUIRED STANDARD. TASK HAS BEEN PERFORMED I.A.W MAINTENANCE MANUAL SPECIFIED IN WORKPACK INDEX LM/QA/GEN/01.

NO	SOURCE	TASK / REFERENCE	REMARKS	MECHANIC SIGN	* AH SIGN & STAMP	DATE
		<p align="center">NOTE</p> <p>IF STEP 2.8 HAS BEEN PERFORMED, INSTALL THE ANTENNA BY MEANS OF EXISTING REMOVED HARDWARE.</p> <p>2.9 IN ACCORDANCE WITH AMP DM 39-B-23-95-04-00A-720A-K AND WITH REFERENCE TO FIGURE 12 VIEW C, INSTALL THE ANTENNA (E107) STS-ISAT-ANT BY MEANS OF N°4 SCREWS P/N MS27039-1-08, N° 4 WASHERS P/N NAS1149D0332K AND SEALANT MIL-S-8802 TY II, CL B-4.</p>	<p>SATISFACTORY INSTALLED</p>	<p>adl</p>	<p>adl</p> <p align="center"></p>	<p>22/2/23</p>
		<p>2.10 IN ACCORDANCE WITH AMP DM 39-A-11-00-01-00A-720A-A AND WITH REFERENCE TO FIGURE 12 VIEW C, APPLY THE DECAL P/N ED300E107 ON THE INTERNAL SIDE OF THE HELICOPTER STRUCTURE.</p>	<p>SATISFACTORY APPLIED</p>	<p>ad</p>	<p>adl</p> <p align="center"></p>	<p>22/2/23</p>
		<p align="center">NOTE</p> <p>IF THE BONDING TEST RESULT ARE NOT WITHIN THE REQUIRED RANGE, MAKE SURE THAT THE SURFACES ARE CLEANED IN ACCORDANCE WITH LH STANDARD AND REPEAT THE TEST. IF THE BONDING TEST RESULT REMAINS OUT OF THE REQUIRED RANGE, INSTALL A CONDUCTIVE GASKET P/N A519A-A000 (GASKET PROFILE TO SUIT EQUIPMENT OUTLINE).</p> <p>2.11 IN ACCORDANCE WITH AMP DM 39-B-23-95-00-00A-320A-K, PERFORM THE EQUIPMENT BONDING TESTS AND PERFORM THE OPERATIONAL CHECK OF THE SATELLITE COMMUNICATION SYSTEM.</p>	<p>SATISFACTORY PERFORMED</p>	<p>HQ</p>	<p>HQ</p>	<p>8/3/23</p>

PARTS / MATERIAL USED / COMPONENT CHANGE RECORD HAVE BEEN RAISED AND ATTACHED.

CALIBRATED / SPECIAL TOOLS RECORD SHEET HAVE BEEN RAISED AND ATTACHED.

* APPROVAL HOLDER HAVE VERIFIED THAT ALL TOOLS, EQUIPMENT AND OTHER EXTRANEIOUS PART OF MATERIALS ARE CLEARED AND ALL TASKS OR INSPECTIONS HAVE BEEN CARRIED OUT TO THE REQUIRED STANDARD. TASK HAS BEEN PERFORMED I.A.W MAINTENANCE MANUAL SPECIFIED IN WORKPACK INDEX LM/QA/GEN/01.

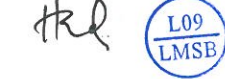
NO	SOURCE	TASK / REFERENCE	REMARKS	MECHANIC SIGN	* AH SIGN & STAMP	DATE
3	-	<p style="text-align: center;">NOTE</p> <p>CUSTOMER MUST CONTACT PRODUCT SUPPORT ENGINEERING (ENGINEERING.SUPPORT.LHD@LEONARDO.COM) AT LEAST 3 MONTHS IN ADVANCE OF EMBODIMENT DATE OF THIS SERVICE BULLETIN IN ORDER TO RECEIVE INFORMATION ON THE EXACT W/D APPLICABLE TO THE HELICOPTER.</p> <p>MODIFY THE OVERHEAD AUXILIARY C/B PANEL AS DESCRIBED IN THE FOLLOWING PROCEDURE:</p> <p>3.1 WITH REFERENCE TO AMP DM 39-A24-91-04-00A-920-A-A, REMOVE FROM OVERHEAD AUXILIARY C/B PANEL THE EXISTING INTEGRALLY-LIGHTED PANEL.</p> <p>3.2 INSTALL THE CIRCUIT BREAKER P/N MS3320-3 WHERE INDICATED ON THE NEW INTEGRALLY LIGHTED PANEL P/N 3G2490LXXXX.</p> <p>3.3 IN ACCORDANCE WITH AMP DM 39-A-11-00-01-00A-720A-A, INSTALL N°1 DECAL P/N ED300CB251 IN AN AREA ADJACENT TO THE PREVIOUSLY INSTALLED CIRCUIT BREAKER.</p> <p>3.4 INSTALL THE SPLITTER P/N MS27723-23 ON THE NEW INTEGRALLY-LIGHTED PANEL P/N 3G2490LXXXX.</p> <p>3.5 IN ACCORDANCE WITH AMP DM 39-A-11-00-01-00A-720A-A, INSTALL N°1 DECAL P/N ED300S298 IN AN AREA ADJACENT TO THE PREVIOUSLY INSTALLED SPLITTER.</p>	<p>REFER TO PSE/TA/2023/00929 AND W/C 2023/154/002-159.</p> <p>SATISFACTORY INSTALLED</p> <p>SATISFACTORY INSTALLED</p> <p>SATISFACTORY INSTALLED</p> <p>SATISFACTORY INSTALLED</p> <p>SATISFACTORY INSTALLED</p>	    	    	<p>10/3/23</p> <p>8/3/23</p> <p>11/3/23</p> <p>8/3/23</p> <p>11/3/23</p>

PARTS / MATERIAL USED / COMPONENT CHANGE RECORD HAVE BEEN RAISED AND ATTACHED. CALIBRATED / SPECIAL TOOLS RECORD SHEET HAVE BEEN RAISED AND ATTACHED.

* APPROVAL HOLDER HAVE VERIFIED THAT ALL TOOLS, EQUIPMENT AND OTHER EXTRANEIOUS PART OF MATERIALS ARE CLEARED AND ALL TASKS OR INSPECTIONS HAVE BEEN CARRIED OUT TO THE REQUIRED STANDARD. TASK HAS BEEN PERFORMED I.A.W MAINTENANCE MANUAL SPECIFIED IN WORKPACK INDEX LM/QA/GEN/01.

Our Ref. :	PSE/TQ/2023/99929	Date:	02 March 2023
From :	LH Service Engineering Leonardo Malaysia	engineering.support.lhd@leonardo.com	
TO :	Attn: Eller Stefan stefan.eller@leonardo.com	Page :	1 / 2
SUBJECT :	AW139 S/N 31763 (TT 392:12 FH): Service Bulletins (SB) embodiment Aux C/B panel		

Dear Sir,

With reference to SB139-334, SB139-348, SB139-624 and SB139-665, please be informed that Leonardo Helicopters (LH) technical advice is as follows.

It is possible to use the existing auxiliary circuit breaker panel P/N 3G2490L03966 for three months starting from the completion embodiment of above mentioned SBs or when the spare part will be available, whichever occurs first, provided that the phosphorescent decals with the following characteristics are installed in accordance with the layout of the new panel P/N 3G2490L06060 reported in Annex A:

- Material specification: MIL-M-43719 Type I, Class 1
- Font: Futura Medium Condensed
- Color: Legend in white with black background
- Character height: 3.18 mm

Please be also informed that the above prescriptions must be considered valid only if the aircraft has been maintained in accordance with all Leonardo Helicopters mandatory recommendations, in addition to local authority requirements.

For any additional information do not hesitate to contact LH Service Engineering.

Best Regards,

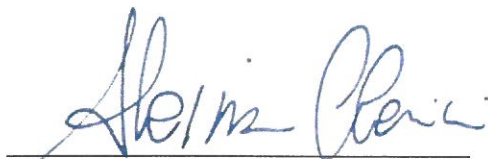

Alessia Clerici
AW139 Chief Project Engineer

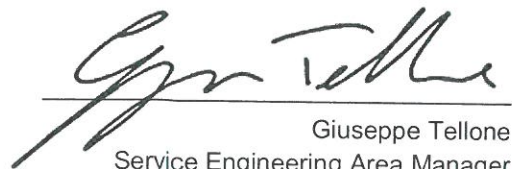

Giuseppe Tellone
Service Engineering Area Manager

The technical content of this document is approved under the authority of DOA no. EASA.21J.005. Please note that this document could be subject to approval from Local Airworthiness Authority, depending on the privileges granted to your organization.

If this document is received incomplete or illegible, please contact engineering.support.lhd@leonardo.com

This facsimile transmission and any accompanying documents are intended only for confidential use of the designated recipient(s) named above. This message may be proprietary information belonging to Leonardo Helicopters. Any such information is privileged and confidential. If you are not the intended recipient or an agent responsible for delivering it to the intended recipient, any disclosure, copying, distribution or action taken in reliance of the contents of the information contained in this facsimile transmission is strictly prohibited. If you have received this transmission in error, please contact us and will arrange for the return of the documents to us at our expense

Leonardo - Società per azioni

Registered Head Office:

Piazza Monte Grappa, 4 - 00195 Rome - Italy

Ph. +39 06 324731 - Fax +39 06 3208621

Head Office:

Via Giovanni Agusta, 520 - 21017 Cascina Costa di Samarate (VA) - Italy

Ph. +39 0331 229111 - Fax +39 0331 229605

elicotteri@pec.leonardo.com

Company Share Capital € 2,543,861,738.00 i.v.

Tax Code & Company Registered no. 00401990585

VAT no. 00881841001

R.E.A. n. 7031



Annex A

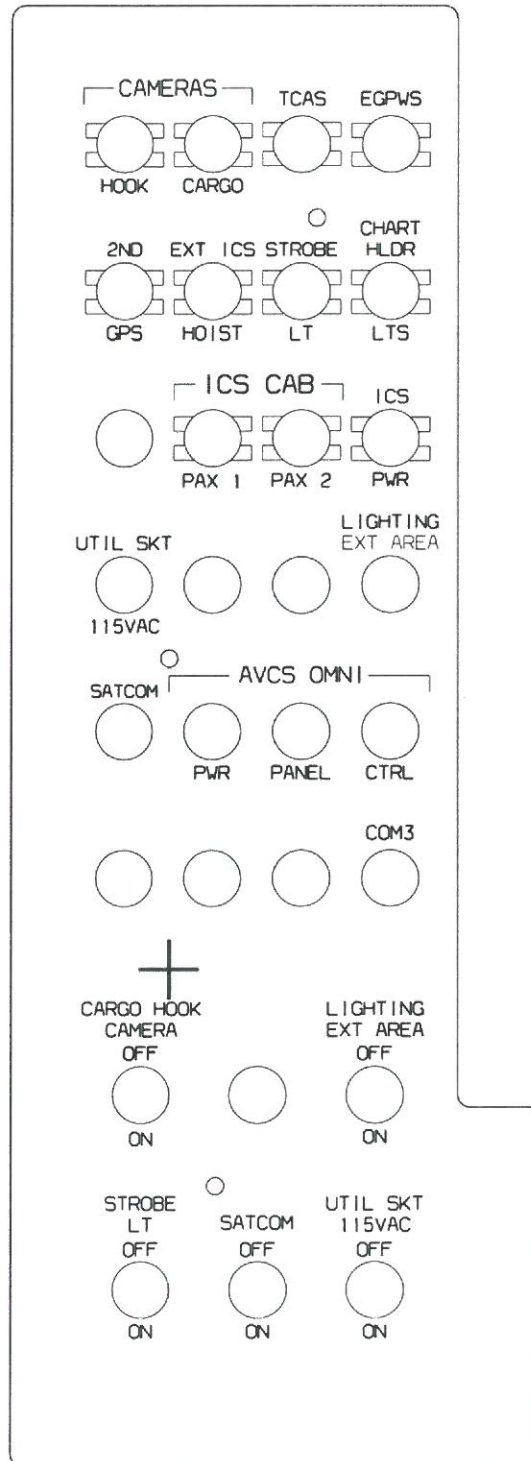

Auxiliary circuit breaker panel P/N 3G2490L06060

Document Reference

Document ID	PSE/TQ/2023/99929	Contact	Stefan Eller
Your Code Reference		Subject	31763 - Service Bulletins (SB) embodiment Aux C/B panel P/N 3G2490L06060
Topic	TECHNICAL	Subtopic	SUPPORT
Issue	TECHNICAL ADVICE	Team Legal Entity	Italy

Contact Details

Customer Description	LEONARDO MALAYSIA SDN BHD	Customer ID	0040000131
Email	stefan.eller@leonardocompany.com		

Customer Service

Priority	HIGH	Creation On (UTC)	28/02/2023
Resolve By (UTC)	04/03/2023	Leonardo Closure Date (UTC)	02/03/2023
Additional Note			

Helicopter Data

ATA Code	24	Description	ELECTRICAL POWER
S/N	N/A	S/N Details	
Helicopter Line	AW139	Helicopter Model	AW139
Repair Instruction Query	False		

Part Number	Component S/N	Component F/H	On (Date)(UTC)
PANEL INTEGRALLY LIGHT AUX BREAKER			

Ticket Description

Dear PSE Team,

MSN 31763 - 392:12 FH, 796 LDG.

Several retro modifications are being fitted to MSN 31763 and this requires a new AUX CB panel to be fitted, SB 139-334, SB 139-348, SB 139-624 and SB 139-665. New CB panel P/N is 3G2490L06060. Refer attachment. Existing AUX CB panel P/N is 3G2490L03966. Refer to attached pictures.

The new AUX CB panel will not arrive in time for the release to service of the aircraft. Estimated RTS is 10th of March 2023.

Please advise possibilities to continue using the existing AUX CB panel for 3 months providing we apply phosphorescent decals with the correct characteristics in accordance with the layout of the new AUX CB panel P/N 3G2490L06060 and installed iaw AMP 39-A-11-00-01-00A-720A-A Decal - Install procedure.

Thank you,

Stefan

History Log

Closing Note

Dear Stefan,

Please refer attached letter to support the helicopter return to service.

Best regards,
Zahin

Ticket Attachments

Attachment's Name	Uploading Date
20230103_094531.jpg	28/02/2023
AW_3G2490L06060_01_A.pdf	28/02/2023
PSE-TQ-2023-99929.pdf	02/03/2023
20230103_094542.jpg	28/02/2023
20230103_094513.jpg	28/02/2023

NO	SOURCE	TASK / REFERENCE	REMARKS	MECHANIC SIGN	* AH SIGN & STAMP	DATE
		3.6 PERFORM ELECTRICAL CONNECTION BETWEEN PL1J3 PIN C AND SPLITTER S298 PIN 3 BY MEANS OF WIRE P/N A556A-T20.	SATISFACTORY INSURED, PERFORMED	<i>[Signature]</i>	L06 LM <i>[Signature]</i>	22/12/23
		3.7 PERFORM ELECTRICAL CONNECTION BETWEEN SPLITTER S298 PIN 2 AND CIRCUIT BREAKER CB251 PIN 2 BY MEANS OF WIRE P/N A556A-T20.	SATISFACTORY PERFORMED	<i>[Signature]</i>	L06 LM <i>[Signature]</i>	22/12/23
		3.8 PERFORM ELECTRICAL CONNECTION BETWEEN CIRCUIT BREAKER CB251 PIN 1 AND 28V MAIN BUS 1 BY MEANS OF WIRE P/N A556A-T20.	SATISFACTORY PERFORMED	<i>[Signature]</i>	L06 LM <i>[Signature]</i>	22/12/23
4	-	IN ACCORDANCE WITH WEIGHT AND BALANCE CHANGES, UPDATE THE CHART A (SEE ROTORCRAFT FLIGHT MANUAL, PART II, SECTION 6).	CAMD TO UPDATE AS APPLICABLE. REFER TO WIC 2025/1544/003-10 FOR AIRCRAFT WEIGHTING.	<i>[Signature]</i>	<i>[Signature]</i> L06 LM	<i>[Signature]</i> 10/13/23
5	-	RETURN THE HELICOPTER TO FLIGHT CONFIGURATION AND RECORD FOR COMPLIANCE WITH PART II OF THIS SERVICE BULLETIN ON THE HELICOPTER LOGBOOK.	SATISFACTORY RETURNED. CAMD TO RECORD AS APPLICABLE.	<i>[Signature]</i>	<i>[Signature]</i> L06 LM	12/3/23
6	-	SEND THE ATTACHED COMPLIANCE FORM TO THE FOLLOWING MAIL BOX: ENGINEERING.SUPPORT.LHD@LEONARDO.COM AS AN ALTERNATIVE, GAIN ACCESS TO MY COMMUNICATIONS SECTION ON LEONARDO WEBPORTAL AND COMPILE THE "SERVICE BULLETIN APPLICATION COMMUNICATION".	PTD TO TAKE NOTE AND SEND AS APPLICABLE.	<i>[Signature]</i>	<i>[Signature]</i> L06 LM	<i>[Signature]</i> 10/13/23

THIS COLUMN INTENTIONALLY LEFT BLANK

PARTS / MATERIAL USED / COMPONENT CHANGE RECORD HAVE BEEN RAISED AND ATTACHED. CALIBRATED / SPECIAL TOOLS RECORD SHEET HAVE BEEN RAISED AND ATTACHED.

* APPROVAL HOLDER HAVE VERIFIED THAT ALL TOOLS, EQUIPMENT AND OTHER EXTRANEIOUS PART OF MATERIALS ARE CLEARED AND ALL TASKS OR INSPECTIONS HAVE BEEN CARRIED OUT TO THE REQUIRED STANDARD. TASK HAS BEEN PERFORMED I.A.W MAINTENANCE MANUAL SPECIFIED IN WORKPACK INDEX LM/QA/GEN/01.

SERVICE BULLETIN

N° 139-624

DATE: March 18, 2022

REV. : /

TITLE

ATA 23 – SATCOM SKYTRACK ISAT-200A KIT INSTALLATION

REVISION LOG

First Issue

An appropriate entry should be made in the aircraft log book upon accomplishment.
If ownership of aircraft has changed, please, forward to new owner.

1. PLANNING INFORMATION

A. EFFECTIVITY

AW139 helicopters from S/N 31700 onwards and from S/N 41500 onwards.

B. COMPLIANCE

At Customer's option.

C. CONCURRENT REQUIREMENTS

N.A.

D. REASON

This Service Bulletin is issued in order to provide the necessary instructions on how to perform the installation of the kit satcom skytrack ISAT-200A P/N 4G2310F03012.

E. DESCRIPTION

The skytrack ISAT-200 satellite communication system lets the flight crew to dial and receive phone calls to and from all places in the world. Also it lets transfer data through the iridium network.

The system includes a cockpit display panel installed in the interseat console in the cockpit, a dispatch voice interface installed in the interseat console adjacent to the cockpit display panel, a transceiver installed in the baggage compartment between STA 7200 and STA 6700 and an antenna installed on a fairing in the left side of the tail section.

Part I of this Service Bulletin provides all necessary instructions on how to perform the SATCOM ISAT-200A complete provision (electrical and structural).

Part II of this Service Bulletin provides all necessary instructions on how to perform the SATCOM ISAT-200A equipment installation.

F. APPROVAL

The technical content of this Service Bulletin is approved under the authority of DOA nr. EASA.21.J.005. For helicopters registered under other Aviation Authorities, before applying the Service Bulletin, applicable Aviation Authority approval must be checked within Leonardo Helicopters customer portal.

EASA states mandatory compliance with inspections, modifications or technical directives and related time of compliance by means of relevant Airworthiness Directives.

If an aircraft listed in the effectivity embodies a modification or repair not LHD certified and affecting the content of this Service Bulletin, it is responsibility of the Owner/Operator to obtain a formal approval by Aviation Authority having jurisdiction on the aircraft, for any adaptation necessary before incorporation of the present Service Bulletin.

G. MANPOWER

To comply with this Service Bulletin one-hundred and twenty (120) MMH are deemed necessary.

MMH are based on hands-on time and can change with personnel and facilities available.

H. WEIGHT AND BALANCE

PART I

WEIGHT (kg)	ARM (mm)	MOMENT (kgmm)
		5.94
LONGITUDINAL BALANCE	8812.0	52343.3
LATERAL BALANCE	-421.0	-2500.7

PART II

WEIGHT (kg)	ARM (mm)	MOMENT (kgmm)
		3.02
LONGITUDINAL BALANCE	5973.0	18038.5
LATERAL BALANCE	-679.0	-2050.6

I. REFERENCES

1) PUBLICATIONS

Following Data Modules refer to AMP:

<u>DATA MODULE</u>	<u>DESCRIPTION</u>	<u>PART</u>
DM01 39-A-00-20-00-00A-120A-A	Helicopter on ground for a safe maintenance	I, II
DM02 39-A-06-41-00-00A-010A-A	Access doors and panels - General data	I, II
DM03 39-A-11-00-01-00A-720A-A	Decal - Install procedure	I, II
DM04 39-B-23-95-05-00A-720A-K	Mounting tray - Install procedure	I
DM05 39-B-23-95-01-00A-720A-K	Cockpit display panel - Install procedure	II

<u>DATA MODULE</u>	<u>DESCRIPTION</u>	<u>PART</u>
DM06 39-B-23-95-02-00A-720A-K	Dispatch voice interface - Install procedure	II
DM07 39-B-23-95-03-00A-720A-K	Transceiver - Install procedure	II
DM08 39-B-23-95-04-00A-720A-K	Antenna - Install procedure	II
DM09 39-B-23-95-00-00A-320A-K	Satellite communication system - Operation test	II

2) ACRONYMS & ABBREVIATIONS

AMDI	Aircraft Material Data Information
AMP	Aircraft Maintenance Publication
CDP	Cockpit Display Panel
DM	Data Module
DOA	Design Organization Approval
DVI	Dispatch Voice Interface
EASA	European Union Aviation Safety Agency
GPS	Global Positioning System
IPD	Illustrated Parts Data
LH	Leonardo Helicopters
MMH	Maintenance-Man-Hours

3) ANNEX

N.A.

J. PUBLICATIONS AFFECTED

AW139 Illustrated Parts Data

K. SOFTWARE ACCOMPLISHMENT SUMMARY

N.A.

2. MATERIAL INFORMATION

A. REQUIRED MATERIALS

1) PARTS

PART I

#	P/N	ALTERNATIVE P/N	DESCRIPTION	Q.TY	LVL	NOTE	LOG P/N
1	4G2310F03012		KIT SATCOM SKYTRACK ISAT-200A	REF	.		-
2	3G2310A13511		SATCOM ISAT-200A COMPLETE PROVISION	REF	..		-
3	3G5310A84311		SATCOM ISAT-200 STRUCTURAL PROVISION	REF	...		-
4	3G5315A61632		Support assy	1		139-624L1
5	3G5315A61731		Cover assy	1		139-624L1
6	3G5316A95531		Bracket assy	1		139-624L1
7	A297A05TW04		Rivet	15		139-624L1
8	A297A05TW05		Rivet	10		139-624L1
9	MS27039-1-08		Screw	4		139-624L1
10	NAS1149D0332K		Washer	4		139-624L1
11	NAS1149DN832K		Washer	2		139-624L1
12	NAS1802-08-5		Screw	2		139-624L1
13	NAS1832-3-3M		Insert	4		139-624L1
14	NAS1836C08-13		Insert	2		139-624L1
15	3G2310A13711		SATCOM ISAT-200A ELECTRICAL PROV	REF	...		-
16	3G9A01A57201	3G2310A13711A1R	Satcom skytrac ISAT - 200A (A1A572)	1		139-624L1
17	3G9A02A50501		Satcom skytrac ISAT - 200A (A2A505)	1		139-624L1
18	3G9B01A97501	3G2310A13711A2R	Satcom skytrac ISAT - 200A (B1A975)	1		139-624L1
19	3G9B02A90701		Satcom skytrac ISAT - 200A (B2A907)	1		139-624L1
20	3G9C01A33401	3G2310A13711A3R	Satcom skytrac ISAT - 200A (C1A334)	1		139-624L1
21	3G9C02A38001		Satcom skytrac ISAT - 200A (C2A380)	1		139-624L1
22	3G9C03C26701		Satcom skytrac ISAT - 200A (C3C267)	1		139-624L1
23	3G9C03C26801		Satcom skytrac ISAT - 200A (C3C268)	1		139-624L1
24	3G9C03C26901		Satcom skytrac ISAT - 200A (C3C269)	1		139-624L1
25	3G9C03C27001		Satcom skytrac ISAT - 200A (C3C270)	1		139-624L1
26	3G9D03B23401		Satcom skytrac ISAT - 200A (D3B234)	1		139-624L1
27	3G9D03B23501	Satcom skytrac ISAT - 200A (D3B235)	1		139-624L1	
28	999-2701-02-296		Decal	2		139-624L1
29	A388A3E06C		Standoff	7		139-624L1
30	A388A3E08C75		Standoff	2		139-624L1
31	A388A3E10C		Standoff	1		139-624L1
32	A388A3E16C		Standoff	4		139-624L1
33	A388A3E24C		Standoff	1		139-624L1

#	P/N	ALTERNATIVE P/N	DESCRIPTION	Q.TY	LVL	NOTE	LOG P/N
34	AW001CB03H		Clamp	1		139-624L1
35	AW001CB05H		Clamp	3		139-624L1
36	AW001CL001-N6		Support	2		139-624L1
37	AW001CL005C01-X		Support	1		139-624L1
38	AW001CL503-N6		Support	1		139-624L1
39	AW001TL3A06		Anchor nut	3		139-624L1
40	AW001TL3A08		Anchor nut	1		139-624L1
41	AW002FT112		Grommet	36		139-624L1
42	DCC-02		Cap	1		139-624L1
43	DCC-03		Cap	1		139-624L1
44	ED300J3042		Decal	1		139-624L1
45	ED300J3044		Decal	1		139-624L1
46	ED300J3090		Decal	1		139-624L1
47	ED300J3091		Decal	1		139-624L1
48	MS21042L02		Nut	8		139-624L1
49	MS25281-R15		Clamp	34		139-624L1
50	MS35206-205		Screw	8		139-624L1
51	NAS1149D0316J		Washer	4		139-624L1
52	NAS1149D0332J		Washer	20		139-624L1
53	NAS1149DN216J		Washer	16		139-624L1
54	NAS1190E3P17AK		Screw	2		139-624L1
55	NAS1190E3P18AK		Screw	6		139-624L1
56	NAS1190E3P22AK		Screw	1		139-624L1
57	NAS1190E3P30AK		Screw	1		139-624L1
58	NAS1190E3P7AK		Screw	8		139-624L1
59	NAS1190E3P8AK		Screw	1		139-624L1
60	NAS1190E3P9AK		Screw	4		139-624L1
61	NAS1802-3-11		Screw	1		139-624L1
62	NAS1802-3-12		Screw	1		139-624L1
63	NAS1802-3-19		Screw	2		139-624L1
64	NAS1802-3-20		Screw	1		139-624L1
65	NAS1802-3-24		Screw	1		139-624L1
66	NAS1802-3-25		Screw	2		139-624L1
67	NAS1802-3-35		Screw	1		139-624L1
68	NAS1802-3-7		Screw	4		139-624L1
69	NAS1802-3-9		Screw	1		139-624L1
70	NAS43DD3-30N		Spacer	4		139-624L1
71	NAS43DD3-35N		Spacer	1		139-624L1
72	NAS43DD3-40N		Spacer	6		139-624L1
73	NAS43DD3-45N		Spacer	1		139-624L1
74	NAS43DD3-47N		Spacer	1		139-624L1
75	NAS43DD3-60N		Spacer	2		139-624L1
76	NAS43DD3-7N		Spacer	4		139-624L1
77	NAS43DD3-90N		Spacer	1		139-624L1

PART II

#	P/N	ALTERNATIVE P/N	DESCRIPTION	Q.TY	LVL	NOTE	LOG P/N
78	4G2310F03012		KIT SATCOM SKYTRACK ISAT-200A	REF	.		
79	3G2310A13611		SATCOM ISAT-200A EQUIPMENT INSTL	REF	..		
80	101-200-07		ISAT-200A	1	...		139-624L2
81	104-300-02		Cockpit display panel CDP-300C	1	...		139-624L2

#	P/N	ALTERNATIVE P/N	DESCRIPTION	Q.TY	LVL	NOTE	LOG P/N
82	105-300-02		Despatch voice interface DVI-300A	1	...		139-624L2
83	ED300A433		Decal	1	...		139-624L2
84	ED300E107		Decal	1	...		139-624L2
85	ED300PL144		Decal	1	...		139-624L2
86	ED300PL145		Decal	1	...		139-624L2
87	MS25083-2BB8	M83413/8-A008BB	Grounding cable assy	1	...		139-624L2
88	STS-ISAT-ANT		Antenna	1	...		139-624L2
89	3G2490LXXXXX		Integrally lit auxiliary C/B panel	1	.	(3)	-
90	MS3320-3		Breaker	1	.		139-624L2
91	ED300CB251		Decal	1	.		139-624L2
92	AW001YC01RED		Lock ring	1	.		139-624L2
93	MS27723-23		Switch	1	.		139-624L2
94	ED300S298		Decal	1	.		139-624L2
95	MS27488-16-2		Filler plug	2	.		139-624L2
96	A556A-T20		Wire	3 m			139-624L2

Refer also to IPD for the spares materials required to comply with the AMP DMs referenced in the accomplishment instructions.

2) CONSUMABLES

The following consumable materials, or equivalent, are necessary to accomplish this Service Bulletin:

#	Spec./LHD code number	DESCRIPTION	Q.TY	NOTE	PART
97	AWMS05-001, TY:I, CL:B, DG:2	Sealant	AR	(1)	I
98	AWMS05-001, TY:I, CL:C, DG:1	Sealant	AR	(1)	I
99	199-05-002, TY:II, CL:2	Adhesive	AR	(1)	I
100	Commercial	Sealant TG8498	AR	(1)	I
101	A236A03AB	Adhesive rubber	AR	(1)	I
102	EN6049-006-25-5	Tubing braided	AR	(1)	I
103	MIL-S-8802 Ty II, CI B-4	Sealant	AR	(1) (2)	II

Refer also to AMDI for the consumable materials required to comply with the AMP DM referenced in the accomplishment instructions.

3) LOGISTIC MATRIX

In order to apply this Service Bulletin, the following Logistic P/N can be ordered in accordance with the applicable notes:

LOGISTIC P/N	Q.TY (PER HELO)	NOTE	PART
139-624L1	1	-	I
139-624L2	1	-	II
3G2490LXXXXX	1	(3)	II

NOTE

- (1) Item to be procured as local supply.
- (2) Sealing compound MC236 (C465) spec. AWMS05-004 Type II can be used as a valid alternative.

(3) The P/N is not properly completed because it is depending on the helicopter configuration. Customers must contact Product Support Engineering (engineering.support.lhd@leonardo.com) to request the new auxiliary CB panel at least three months in advance from the scheduled application of this Service Bulletin.

B. SPECIAL TOOLS

N.A.

C. INDUSTRY SUPPORT INFORMATION

Customization.

3. ACCOMPLISHMENT INSTRUCTIONS

GENERAL NOTES

- a) Place an identification tag on all components that are re-usable, including the attaching hardware that has been removed to gain access to the modification area and adequately protect them until their later re-use.
- b) Exercise extreme care during drilling operations to prevent instruments, cables and hoses damage.
- c) After drilling, remove all swarf and sharp edges. Apply on bare metal a light film of primer unless the hole is used for ground connection.
- d) Shape the cables in order to prevent interference with the structure and the other existing installations, using where necessary suitable lacing cords.
- e) During the installation of bonding braids or components requiring grounding, clean the surface structure in order to obtain a good ground contact.
- f) Protect properly all those equipment not removed from area affected by the modification during installation procedure.
- g) Let the adhesive cure at room temperature for at least 24 hours, unless otherwise specified.
- h) All lengths are in mm.

PART I

1. In accordance with AMP DM 39-A-00-20-00-00A-120A-A prepare the helicopter on ground for a safe maintenance. Disconnect the battery, all electrical power sources and/or the external power supply.
2. In accordance with AMP DM 39-A-06-41-00-00A-010A-A and with reference to Figures 1 thru 13, gain access to the area affected by the installation and perform SATCOM ISAT-200A complete provision P/N 3G2310A13511 as described in the following procedure:
 - 2.1 With reference to Figures 1 thru 3, perform satcom ISAT-200 structural provision P/N 3G5310A84311 as described in the following procedure:

- 2.1.1 With reference to Figure 2 View Looking Inboard Left Side, gain access to the rear fuselage assy.
- 2.1.2 With reference to Figure 2 View A-A and Section B-B, drill n°4 holes $\varnothing 14.25 \div 14.38$ thru the FWD floor assy P/N 3P5340A44031 in accordance with the dimensioning shown.
- 2.1.3 With reference to Figure 2 Section B-B, install n°4 inserts P/N NAS1832-3-3M on the FWD floor assy P/N 3P5340A44031 by means of adhesive 199-05-002 Type II Class 2.
- 2.1.4 With reference to Figure 2 View A-A and Section K-K, clean the surface of the spar to obtain a good ground contact.
- 2.1.5 With reference to Figure 2 View A-A and Section K-K, temporarily locate the bracket assy P/N 3G5316A95531 on the FWD floor assy P/N 3P5340A44031.
- 2.1.6 With reference to Figure 2 View A-A and Section K-K, drill n°2 holes $\varnothing 11.48 \div 11.61$ on the FWD floor assy P/N 3P5340A44031 in accordance with the dimensioning shown.
- 2.1.7 With reference to Figure 2 Section K-K, install n°2 inserts P/N NAS1836C08-13 on the FWD floor assy P/N 3P5340A44031 by means of adhesive 199-05-002 Type II Class 2.
- 2.1.8 With reference to Figure 2 View A-A and Section K-K, install the bracket assy P/N 3G5316A95531 on the FWD floor assy P/N 3P5340A44031 by means of n°2 screws P/N NAS1802-08-5 and n°2 washers P/N NAS1149DN832K.
- 2.1.9 With reference to Figure 1 View Looking Inboard Left side, gain access to the tail boom assy.
- 2.1.10 With reference to Figure 3 View G and Section F-F, perform the indicated cut-out on the RW tail gearbox fairing and on the bonding layer P/N 3G5355A06151 and prepare the surface to assure ground contact.
- 2.1.11 With reference to Figure 1 View C, temporarily locate the support assy P/N 3G5315A61632 on the RW tail gearbox fairing.

NOTE

Do not apply the sealant in the bonding layer zone.

NOTE

Use sealant AWMS05-001 Ty.I Gr.1 Cl.2 on the overlapping zone and AWMS05-001 Ty.I CL.B to create an adhesive bead around the part edge.

- 2.1.12 With reference to Figure 3 Section E-E, apply the sealant AWMS05-001 TY I, Gr 2, Cl B and AWMS05-001 TY I, Gr 1, Cl C around the perimeter of the RW tail gearbox fairing.
- 2.1.13 With reference to Figure 1 View C, install the support assy P/N 3G5315A61632 on the RW tail gearbox fairing by means of n°15 rivets P/N A297A05TW04 and n°10 rivets P/N A297A05TW05 in accordance with the pilot holes on the support assy P/N 3G5315A61632.

NOTE

Perform the following step 2.1.14 only if Part II of this Service Bulletin is not intended to be done immediately after Part I. Otherwise skip at step 2.2.

- 2.1.14 With reference to Figure 3 Section E-E, View H and Section J-J, install the cover assy P/N 3G5315A61731 on the support assy P/N 3G5315A61632 by means of n°4 screws P/N MS27039-1-08, n° 4 washers P/N NAS1149D0332K and sealant TG8498.

NOTE

Use the edging P/N A236A on edges which are liable to cause damage to cable assemblies or where abrasion may occur.

NOTE

Install the tubing braided P/N A582A where protection against chafing and prevention of contact with structure may occur, but the tubing protection is not substitute for good routing practice.

- 2.2 With reference to Figures 4 thru 11, perform satcom ISAT-200 electrical provision P/N 3G2310A13711 as described in the following procedure:
 - 2.2.1 In accordance with the applicable steps of AMP DM 39-B-23-95-05-00A-720A-K and with reference to Figure 8 View A, install the processor tray P/N 102-200-05 by means of n°4 screws P/N NAS1802-3-7, n°4 washers P/N NAS1149D0316J and n°4 spacers P/N NAS43DD3-7.

- 2.2.2 With reference to Figure 8 View A, install n°2 supports P/N AW001CL001-N6 on the structure at locations n°2 and 3.
- 2.2.3 With reference to Figure 8 View B, install the standoff P/N A388A3E24C on the structure at location n°1.
- 2.2.4 With reference to Figure 8 View B, install the support P/N AW001CL503-N6 on the structure.
- 2.2.5 With reference to Figure 9 View Looking Rear Fuselage LH side, install the anchor nut P/N AW001TL3A08 on the structure at location n°1.
- 2.2.6 With reference to Figure 9 View Looking Rear Fuselage LH side, install n°4 standoffs P/N A388A3E16C at locations n°2, 3, 4 and 5.
- 2.2.7 With reference to Figure 9 View Looking Rear Fuselage LH side, install n°2 anchor nuts P/N AW001TL3A06 on the structure at locations n°6 and 8.
- 2.2.8 With reference to Figure 9 View Looking Rear Fuselage LH side, install the standoff P/N A388A3E06C at location n°7.
- 2.2.9 With reference to Figure 10 View Looking Tail LH side, install n°6 standoff P/N A388A3E06C at locations n°1, 2, 4, 5, 6 and 8.
- 2.2.10 With reference to Figure 10 View Looking Tail LH side, install the anchor nut P/N AW001TL3A06 on the structure at location n°3.
- 2.2.11 With reference to Figure 10 View Looking Tail LH side, install the support P/N AW001CL005C01-X1 at location n°7.
- 2.2.12 With reference to Figure 11 View Looking Vertical Tail Fin, install n°2 standoffs P/N A388A3E08C75 at locations n°2 and 3.
- 2.2.13 With reference to Figure 11 View Looking Vertical Tail Rotor, install the standoff P/N A388A3E10C at location n°1.
- 2.2.14 With reference to Figures 4 thru 11, lay down the following cable assemblies on the existing routes unless otherwise indicated on the figures:
- 3G9A01A57201 satcom skytrac ISAT - 200A C/A (A1A572)
 - 3G9A02A50501 satcom skytrac ISAT - 200A C/A (A2A505)
 - 3G9B01A97501 satcom skytrac ISAT – 200A C/A (B1A975)
 - 3G9B02A90701 satcom skytrac ISAT – 200A C/A (B2A907)
 - 3G9C01A33401 satcom skytrac ISAT – 200A C/A (C1A334)
 - 3G9C02A38001 satcom skytrac ISAT – 200A C/A (C2A380)
 - 3G9C03C26701 satcom skytrac ISAT – 200A C/A (C3C267)
 - 3G9C03C26801 satcom skytrac ISAT – 200A C/A (C3C268)

- 3G9C03C26901 satcom skytrac ISAT – 200A C/A (C3C269)
 - 3G9C03C27001 satcom skytrac ISAT – 200A C/A (C3C270)
 - 3G9D03B23401 satcom skytrac ISAT – 200A C/A (D3B234)
 - 3G9D03B23501 satcom skytrac ISAT – 200A C/A (D3B235)
- 2.2.15 With reference to Figures 4 thru 11, secure the cable assemblies laid down at the previous step by means of existing hardware and lacing cords.
- 2.2.16 With reference to Figure 8 View A, install the clamp P/N AW001CB03H on the C/A C1A334 and the clamp P/N AW001CB05H on the C/A C2A380 to fix the C/As to the support by means of the screw P/N NAS1802-3-9 and the washer P/N NAS1149D0332J.
- 2.2.17 With reference to Figure 8 View B, install the clamp P/N MS25281-R15 on the C/A C3C269 and C/A C3C270 to fix the C/As to the standoff by means of the screw P/N NAS1190E3P8AK, the washer P/N NAS1149D0332J and the grommet P/N AW002FT112.
- 2.2.18 With reference to Figure 8 View B, install the grommet P/N AW002FT112 on the support on the C/A C3C269 and C/A C3C270.
- 2.2.19 With reference to Figure 9 View Looking Rear Fuselage LH side, apply adhesive rubber P/N A236A03AB in the indicated positions around the edges of the structure's holes.
- 2.2.20 With reference to Figure 9 View Looking Rear Fuselage LH side, install n°2 clamps P/N MS25281-R15 on the C/A C3C269 and C/A C3C270 to fix the C/As to n°2 anchor nuts by means of n°2 screws P/N NAS1802-3-19, n°2 washers P/N NAS1149D0332J, n°2 spacers P/N NAS43DD3-30N and n°2 grommets P/N AW002FT112.
- 2.2.21 With reference to Figure 9 View Looking Rear Fuselage LH side, install n°4 clamps P/N MS25281-R15 on the C/A C3C269 and C/A C3C270 to fix the C/As to n°4 standoffs by means of n°4 screws P/N NAS1190E3P9AK, n°4 washers P/N NAS1149D0332J and n°4 grommets P/N AW002FT112.
- 2.2.22 With reference to Figure 9 View Looking Rear Fuselage LH side, install the clamp P/N MS25281-R15 on the C/A C3C269 and C/A C3C270 to fix the C/As to the anchor nut by means of the screw P/N NAS1802-3-20, the washer P/N NAS1149D0332J, the spacer P/N NAS43DD3-35N and the grommet P/N AW002FT112.

- 2.2.23 With reference to Figure 9 View Looking Rear Fuselage LH side, install the clamp P/N MS25281-R15 on the C/A C3C269 and C/A C3C270 to fix the C/As to the standoff by means of the screw P/N NAS1190E3P7AK, the washer P/N NAS1149D0332J and the grommet P/N AW002FT112.
- 2.2.24 With reference to Figure 10 View Looking Tail LH side, install n°6 clamps P/N MS25281-R15 on the C/A D3B234 and C/A D3B235 to fix the C/As to n°6 standoffs by means of n°6 screws P/N NAS1190E3P7AK, n°6 washers P/N NAS1149D0332J and n°6 grommets P/N AW002FT112.
- 2.2.25 With reference to Figure 10 View Looking Tail LH side, install the clamp P/N MS25281-R15 on the C/A D3B234 and C/A D3B235 to fix the C/As to the anchor nut by means of the screw P/N NAS1802-3-11, the washer P/N NAS1149D0332J and the grommet P/N AW002FT112.
- 2.2.26 With reference to Figure 10 View Looking Tail LH side, install n°3 clamps P/N MS25281-R15 on the C/A D3B234 and C/A D3B235 to fix the C/As to existing standoff by means of n°3 grommets P/N AW002FT112.
- 2.2.27 With reference to Figure 10 View Looking Tail LH side, remove existing screw and install the clamp P/N MS25281-R15 on the C/A D3B234 and C/A D3B235 to fix the C/As to existing anchor nut by means of the screw P/N NAS1802-3-25, the spacer P/N NAS43DD3-47N and the grommet P/N AW002FT112.
- 2.2.28 With reference to Figure 10 View Looking Tail LH side, install the grommet P/N AW002FT112 on the support on the C/A D3B234 and C/A D3B235.
- 2.2.29 With reference to Figure 10 View Looking Tail LH side, remove existing screw (on kit P/N 3G2560A02213) and install n°2 clamps P/N MS25281-R15 on the C/A D3B234 and C/A D3B235 to fix the C/As to existing standoffs by means of n°2 screws P/N NAS1190E3P17AK, n°2 spacers P/N NAS43DD3-30N and n°2 grommets P/N AW002FT112.
- 2.2.30 With reference to Figure 11 View Looking Vertical Tail Fin, remove existing screw and install the clamp P/N MS25281-R15 on the C/A D3B234 and C/A D3B235 to fix the C/As to existing anchor nut by means of the screw P/N NAS1802-3-35, the spacer P/N NAS43DD3-60N and the grommet P/N AW002FT112.
- 2.2.31 With reference to Figure 11 View Looking Vertical Tail Fin, install the clamp P/N MS25281-R15 on the C/A D3B234 and C/A D3B235 to fix the

- C/As to the standoff by means of the screw P/N NAS1190E3P30AK, the washer P/N NAS1149D0332J, the spacer P/N NAS43DD3-90N and the grommet P/N AW002FT112.
- 2.2.32 With reference to Figure 11 View Looking Vertical Tail Fin, install the clamp P/N MS25281-R15 on the C/A D3B234 and C/A D3B235 to fix the C/As to the standoff by means of the screw P/N NAS1190E3P22AK, the washer P/N NAS1149D0332J, the spacer P/N NAS43DD3-60N and the grommet P/N AW002FT112.
- 2.2.33 With reference to Figure 11 View Looking Vertical Tail Fin, remove existing screws and install n°6 clamps P/N MS25281-R15 on the C/A D3B234 and C/A D3B235 to fix the C/As to existing standoffs by means of n°6 screws P/N NAS1190E3P18AK, n°6 spacers P/N NAS43DD3-40N and n°6 grommets P/N AW002FT112.
- 2.2.34 With reference to Figure 11 View Looking Vertical Tail Fin, remove existing screw and install the clamp P/N MS25281-R15 on the C/A D3B234 and C/A D3B235 to fix the C/As to existing support by means of the screw P/N NAS1802-3-12, the spacer P/N NAS43DD3-45N and the grommet P/N AW002FT112.
- 2.2.35 With reference to Figure 11 View Looking Tail Rotor, remove existing screw and install the clamp P/N MS25281-R15 on the C/A D3B234 and C/A D3B235 to fix the C/As to existing standoff by means of the screw P/N NAS1802-3-25 and the grommet P/N AW002FT112.
- 2.2.36 With reference to Figure 11 View Looking Tail Rotor, remove existing screw and install the clamp P/N MS25281-R15 on the C/A D3B234 and C/A D3B235 to fix the C/As to existing standoff by means of the screw P/N NAS1802-3-24 and the grommet P/N AW002FT112.
- 2.2.37 With reference to Figure 11 View Looking Tail Rotor, install n°2 clamps P/N AW001CB05H on the C/A D3B234 and C/A D3B235 to fix the C/As to the standoff by means of the screw P/N NAS1190E3P7AK and the washer P/N NAS1149D0332J.
- 2.2.38 With reference to Figure 5, Figure 6 and Figure 14 wiring diagram, perform the electrical connection of C/A A1A572 to connector A7-6P1, to connector P127, to connector TB123P1, to terminal board TB129/3 and to terminal board TB137/1.

- 2.2.39 With reference to Figure 5, Figure 6 and Figure 14, Figure 15 wiring diagram, perform the electrical connection of C/A A2A505 to connectors P133, PL144P1, PL145P1 and TB147P1.
- 2.2.40 With reference to Figure 5, Figure 6, Figure 7 and Figure 14, Figure 15 wiring diagram, perform the electrical connection of C/A B1A975 to connector J127, to connector J215 and to connector PL1P3.
- 2.2.41 With reference to Figure 6, Figure 7 and Figure 14 wiring diagram, perform the electrical connection of C/A B2A907 to connector J133 and to connector J217.
- 2.2.42 With reference to Figure 8 and Figure 15 wiring diagram, perform the electrical connection of C/A C1A334 to connector P215, to terminal board TB307 and to terminal board TB315.
- 2.2.43 In accordance with the applicable steps of AMP DM 39-B-23-95-05-00A-720A-K and with reference to Figure 8 View A, install the connector A433P1A and the connector A433P1B to the mounting tray.
- 2.2.44 With reference to Figure 8 View A and Figure 15 wiring diagram, perform the electrical connection of C/A C2A380 to connector A433P1A, to connector A433P1B and to connector P217.
- 2.2.45 With reference to Figure 8 View A and Figure 16 wiring diagram, perform the electrical connection of C/A C3C267 to connector A433P1A.
- 2.2.46 With reference to Figure 8 View A and Figure 16 wiring diagram, perform the electrical connection of C/A C3C268 to connector A433P1A.
- 2.2.47 With reference to Figure 8 View A, install the connector J3090 on the bracket assy P/N 3G5316A95531 (previously installed) by means of n°4 screws P/N MS35206-205, n°4 nuts P/N MS21042L02 and n° 8 washers P/N NAS1149DN216J.
- 2.2.48 In accordance with AMP DM 39-A-11-00-01-00A-720A-A and with reference to Figure 8 View A, apply the decal P/N ED300J3090 next to the connector J3090.
- 2.2.49 With reference to Figure 8 View A, connect the connector P3090 to the connector J3090.
- 2.2.50 With reference to Figure 8 View A, install the connector J3091 on the bracket assy P/N 3G5316A95531 (previously installed) by means of n°4 screws P/N MS35206-205, n°4 nuts P/N MS21042L02 and n° 8 washers P/N NAS1149DN216J.

- 2.2.51 In accordance with AMP DM 39-A-11-00-01-00A-720A-A and with reference to Figure 8 View A, apply the decal P/N ED300J3091 next to the connector J3091.
- 2.2.52 With reference to Figure 8 View A, connect the connector P3091 to the connector J3091.
- 2.2.53 With reference to Figure 10 View Looking Tail LH Side, connect the connector P3044 to the connector J3044 and the connector P3042 to the connector J3042.
- 2.2.54 In accordance with AMP DM 39-A-11-00-01-00A-720A-A and with reference to Figure 10 View Looking Tail LH Side, apply n°2 decals P/N ED300J3044 and P/N 999-2701-02-296 next to the connector J3044 and n°2 decals P/N ED300J3042 and P/N 999-2701-02-296 next to the connector J3042.

NOTE

Perform the following step 2.2.55 and 2.2.56 if Part II of this Service Bulletin is not intended to be embodied immediately after Part I. Otherwise skip at step 2.2.57.

- 2.2.55 With reference to Figure 5 Detail C and Figure 6 View Looking Left Cockpit Pedestal, protect the connector PL145P1 with the protective cap P/N DCC-02 nomex fibre sleeve P/N A582A25 and tie strap P/N 900004953.
 - 2.2.56 With reference to Figure 5 Detail C and Figure 6 View Looking Left Cockpit Pedestal, protect the connector PL144P1 with the protective cap P/N DCC-03 nomex fibre sleeve P/N A582A25 and tie strap P/N 900004953.
 - 2.2.57 Perform a pin-to-pin continuity check of all the electrical connections made.
3. In accordance with weight and balance changes, update the Chart A (see Rotorcraft Flight Manual, Part II, section 6).
 4. Return the helicopter to flight configuration and record for compliance with Part I of this Service Bulletin on the helicopter logbook.
 5. Send the attached compliance form to the following mail box:

engineering.support.lhd@leonardo.com

As an alternative, gain access to My Communications section on Leonardo WebPortal and compile the "Service Bulletin Application Communication".

PART II

1. In accordance with AMP DM 39-A-00-20-00-00A-120A-A prepare the helicopter on ground for a safe maintenance. Disconnect the battery, all electrical power sources and/or the external power supply.

NOTE

If necessary, in order to ensure a proper installation of the equipment, it is possible to use bolts (length only) and/or screws (length only) and/or spacers (length only) and/or washers (thickness only) of two increments greater or lesser with respect to the indicated ones.

2. In accordance with AMP DM 39-A-06-41-00-00A-010A-A and with reference to Figure 12, gain access to the area affected by the installation and perform the SATCOM ISAT-200A equipment installation P/N 3G2310A13611 as described in the following procedure:

- 2.1 With reference to Figure 13 View A, remove the panel P/N 999-0500-85-231 from the interseat console.

NOTE

Perform the following step 2.2 only if Part II of this Service Bulletin is not performed immediately after Part I. Otherwise skip at step 2.3

- 2.2 With reference to Figure 13 View A and Detail D, remove the tie straps, the nomex fibre sleeves and the protective caps from the connectors PL145P1 and PL144P1.
- 2.3 In accordance with AMP DM 39-B-23-95-01-00A-720A-K and with reference to Figure 13 View A, install the cockpit display panel CDP-300C P/N 104-300-02 in the interseat console.
- 2.4 In accordance with AMP DM 39-B-23-95-02-00A-720A-K and with reference to Figure 13 View A, install the dispatch voice interface DVI-300A P/N 105-300-02 in the interseat console.
- 2.5 In accordance with AMP DM 39-A-11-00-01-00A-720A-A and with reference to Figure 13 View A, apply the decal P/N ED300PL145 on the cockpit display panel CDP-300C P/N 104-300-02 and the decal P/N ED300PL144 on the dispatch voice interface DVI-300A P/N 105-300-02.
- 2.6 In accordance with the applicable steps of AMP DM 39-B-23-95-03-00A-720A-K and with reference to Figure 13 View B and View E, install the transceiver ISAT-200A P/N 101-200-07 and the ground cable P/N MS25083-2BB8 on the tray.
- 2.7 In accordance with AMP DM 39-A-11-00-01-00A-720A-A and with reference to Figure 13 View B, apply the decal P/N ED300A433 on the transceiver

ISAT-200A.

NOTE

Perform the following step 2.8 only if Part II of this Service Bulletin is not performed immediately after Part I. Otherwise skip at step 2.9.

- 2.8 With reference to Figure 12 View C, remove the cover P/N 3G5315A61731 from the support assy P/N 3G5315A61632. Retain the hardware for later reuse.

NOTE

If step 2.8 has been performed, install the antenna by means of existing removed hardware.

- 2.9 In accordance with AMP DM 39-B-23-95-04-00A-720A-K and with reference to Figure 12 View C, install the antenna (E107) STS-ISAT-ANT by means of n°4 screws P/N MS27039-1-08, n° 4 washers P/N NAS1149D0332K and sealant MIL-S-8802 Ty II, CI B-4.
- 2.10 In accordance with AMP DM 39-A-11-00-01-00A-720A-A and with reference to Figure 12 View C, apply the decal P/N ED300E107 on the internal side of the helicopter structure.

NOTE

If the bonding test result are not within the required range, make sure that the surfaces are cleaned in accordance with LH standard and repeat the test. If the bonding test result remains out of the required range, install a conductive gasket P/N A519A-A000 (gasket profile to suit equipment outline).

- 2.11 In accordance with AMP DM 39-B-23-95-00-00A-320A-K, perform the equipment bonding tests and perform the operational check of the satellite communication system.

NOTE

Customer must contact Product Support Engineering (engineering.support.lhd@leonardo.com) at least 3 months in advance of embodiment date of this Service Bulletin in order to receive information on the exact W/D applicable to the helicopter.

3. Modify the overhead Auxiliary C/B panel as described in the following procedure:

- 3.1 With reference to AMP DM 39-A24-91-04-00A-920-A-A, remove from overhead

Auxiliary C/B panel the existing Integrally-lighted panel.

- 3.2 Install the circuit breaker P/N MS3320-3 where indicated on the new Integrally-lighted panel P/N 3G2490LXXXXX.
 - 3.3 In accordance with AMP DM 39-A-11-00-01-00A-720A-A, install n°1 decal P/N ED300CB251 in an area adjacent to the previously installed circuit breaker.
 - 3.4 Install the splitter P/N MS27723-23 on the new Integrally-lighted panel P/N 3G2490LXXXXX.
 - 3.5 In accordance with AMP DM 39-A-11-00-01-00A-720A-A, install n°1 decal P/N ED300S298 in an area adjacent to the previously installed splitter.
 - 3.6 Perform electrical connection between PL1J3 pin c and splitter S298 pin 3 by means of wire P/N A556A-T20.
 - 3.7 Perform electrical connection between splitter S298 pin 2 and circuit breaker CB251 pin 2 by means of wire P/N A556A-T20.
 - 3.8 Perform electrical connection between circuit breaker CB251 pin 1 and 28V MAIN BUS 1 by means of wire P/N A556A-T20.
4. In accordance with weight and balance changes, update the Chart A (see Rotorcraft Flight Manual, Part II, section 6).
 5. Return the helicopter to flight configuration and record for compliance with Part II of this Service Bulletin on the helicopter logbook.
 6. Send the attached compliance form to the following mail box:

engineering.support.lhd@leonardo.com

As an alternative, gain access to My Communications section on Leonardo WebPortal and compile the "Service Bulletin Application Communication".

**SAT/COM ISAT-200
STRUCTURAL PROVISION**

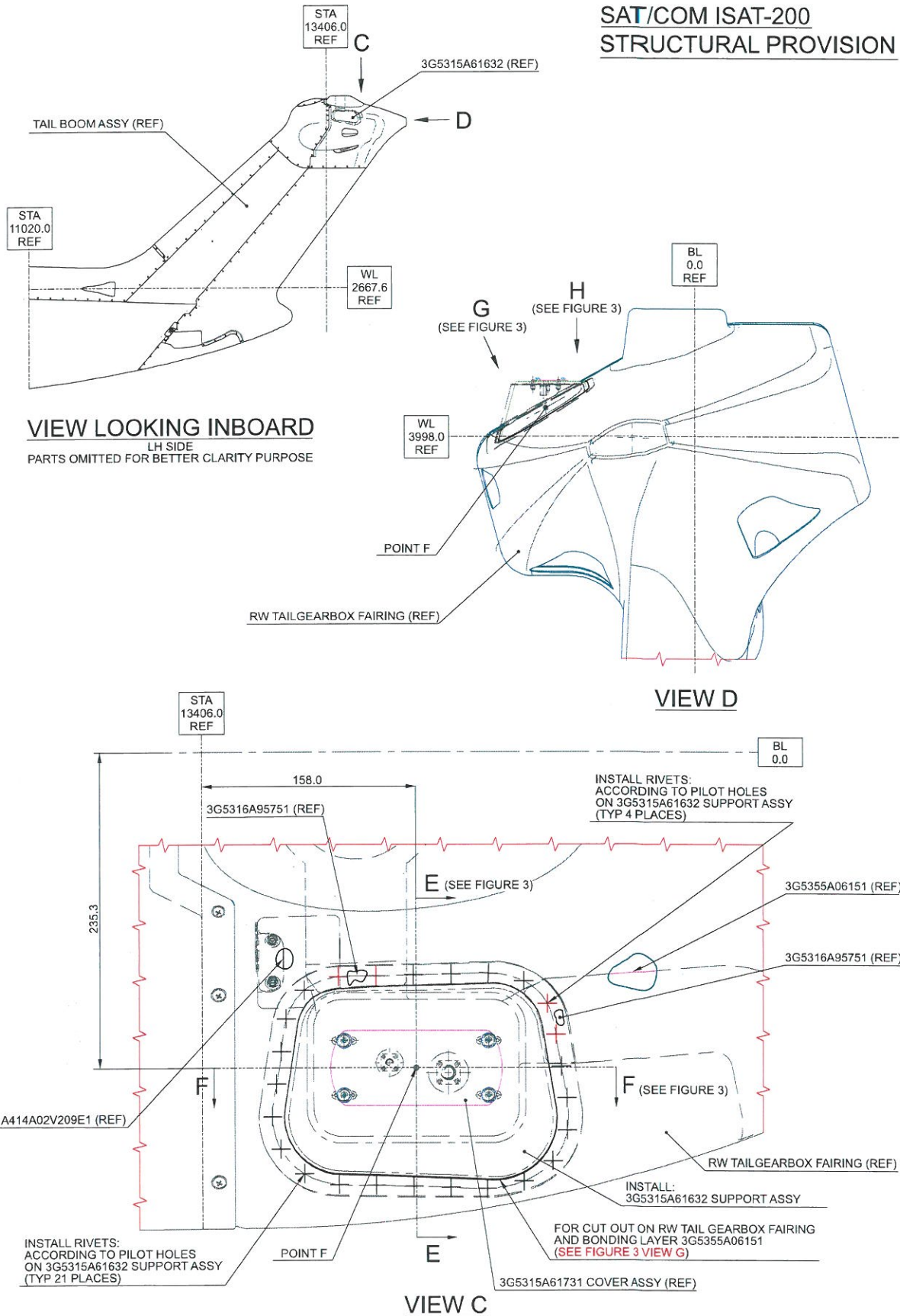

Figure 1

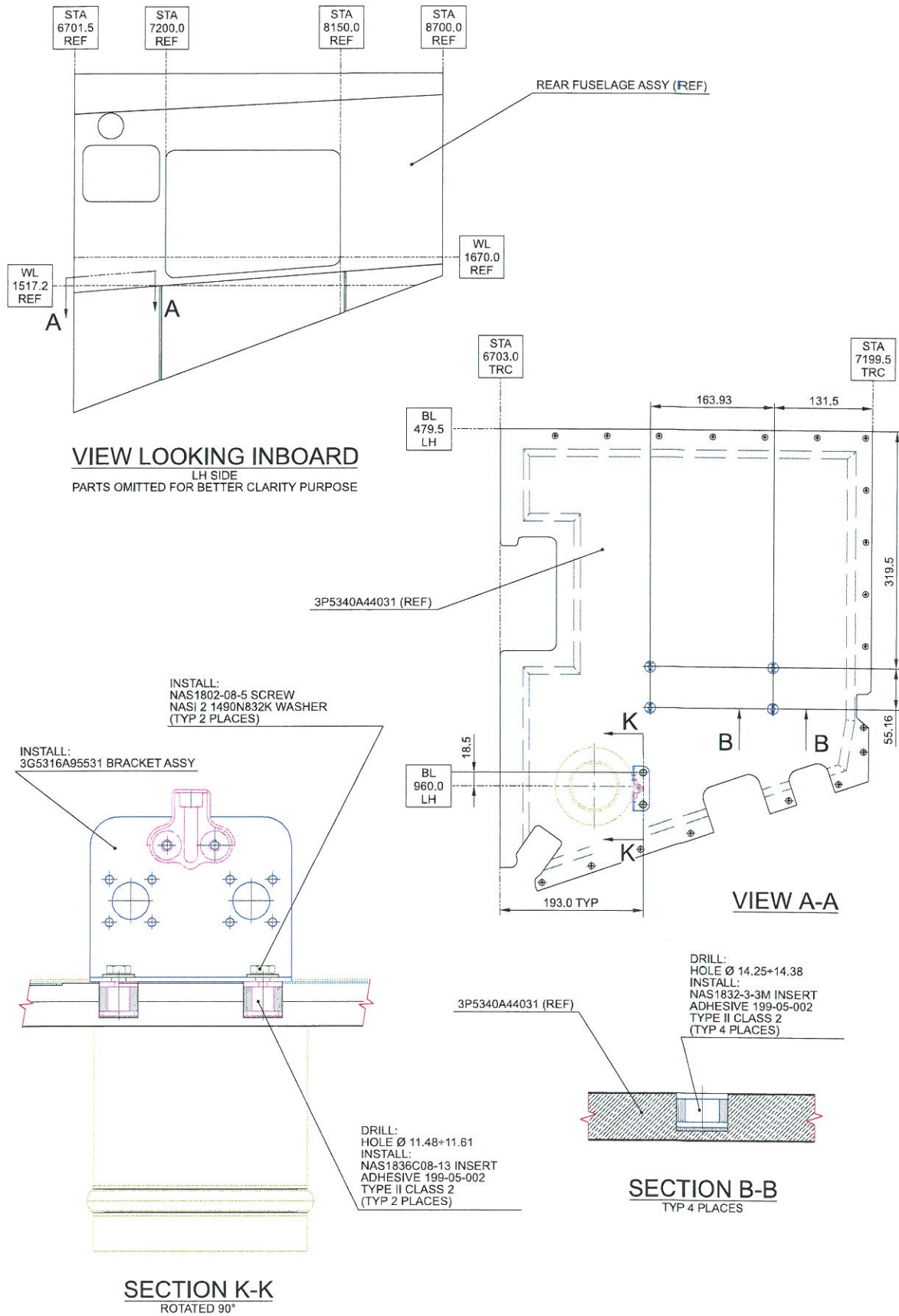
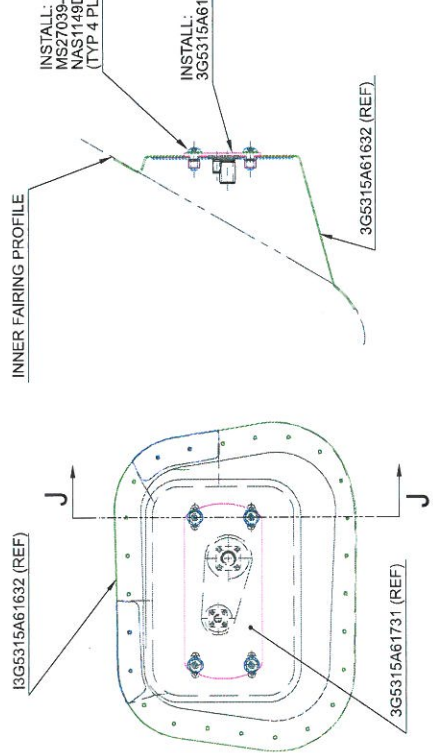
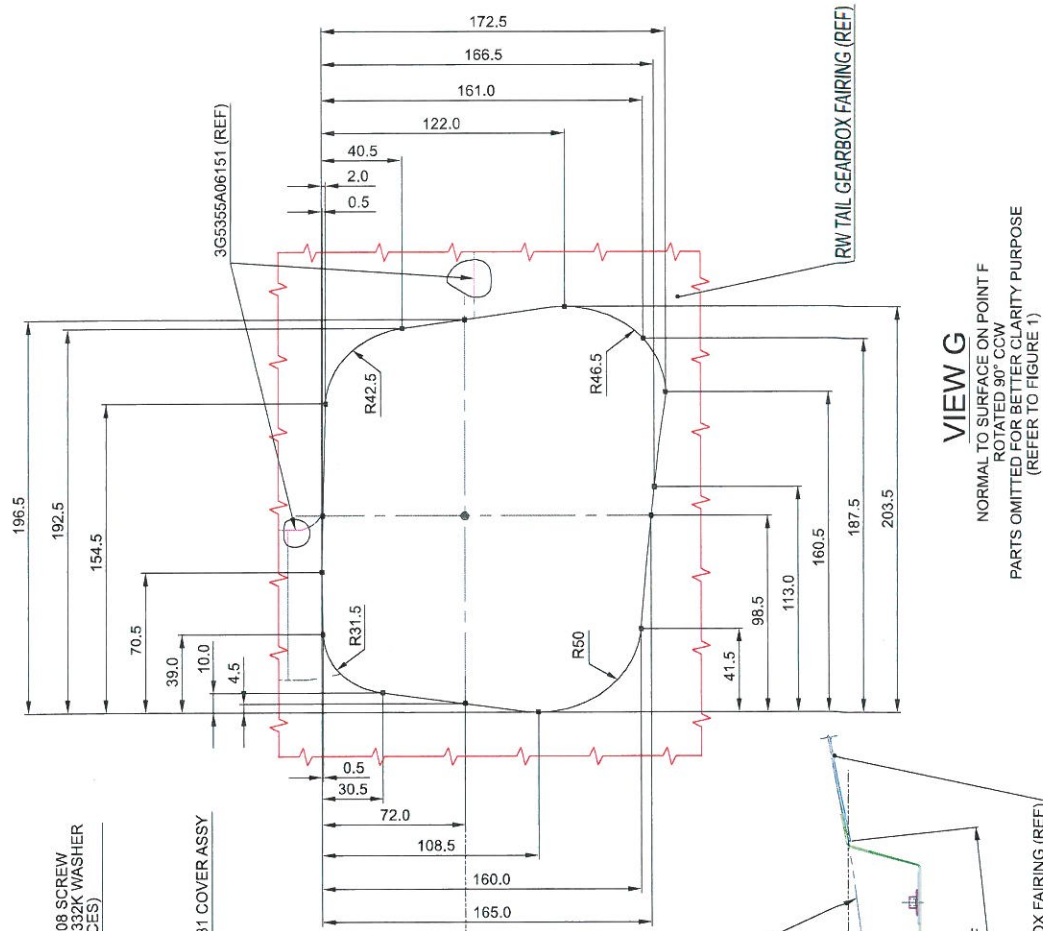
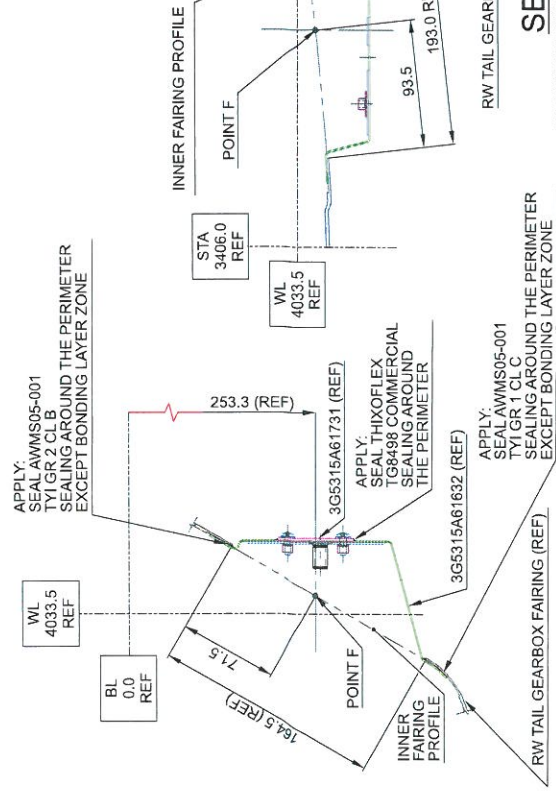

Figure 2



SECTION J-J

VIEW H
ROTATED 90° CCW
PARTS OMITTED FOR BETTER CLARITY PURPOSE
(REFER TO FIGURE 1)



SECTION F-F

SECTION E-E
PARTS OMITTED FOR BETTER CLARITY PURPOSE
(REFER TO FIGURE 1)

Figure 3

**SAT/COM ISAT-200
ELECTRICAL PROVISION**

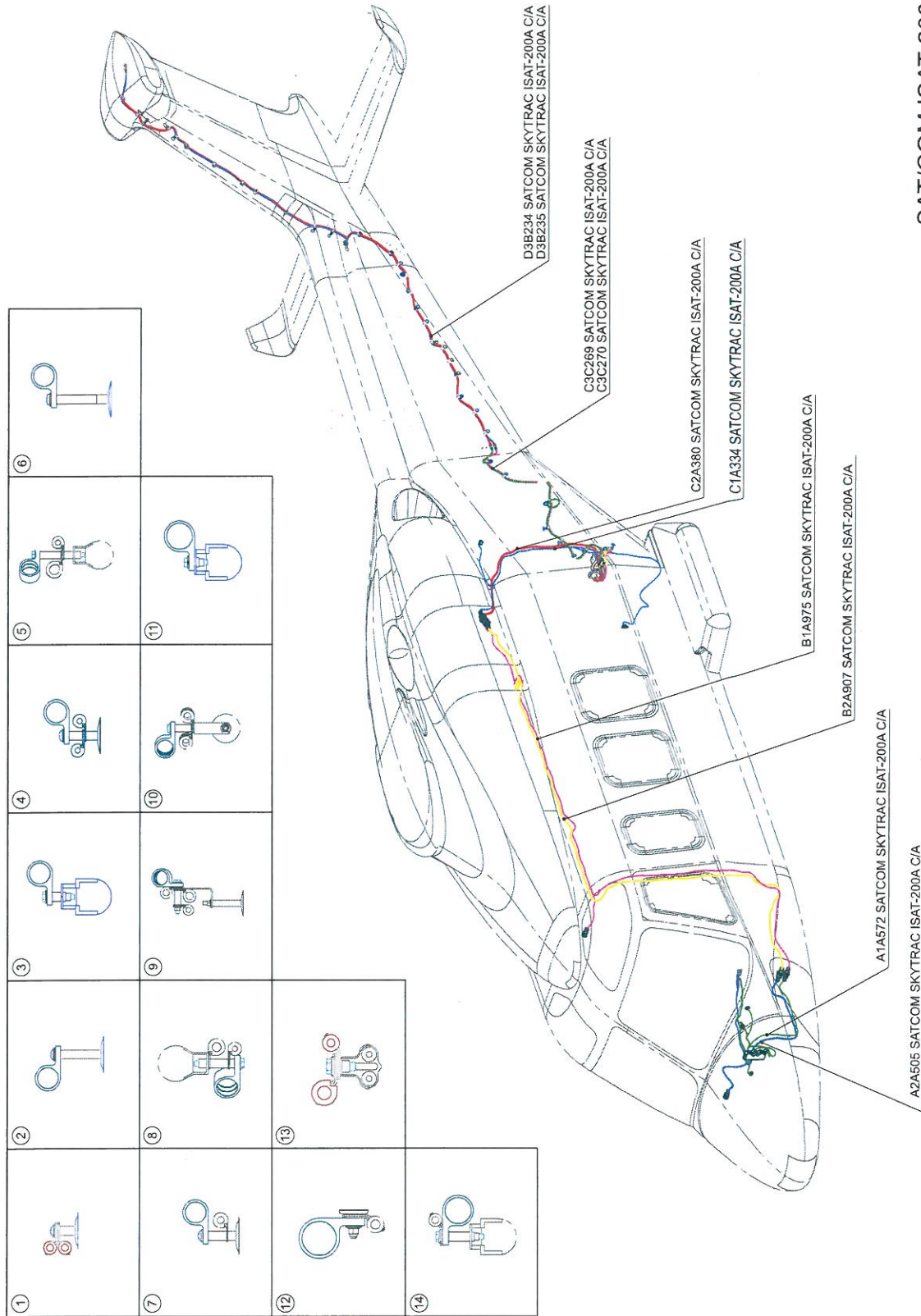

Figure 4

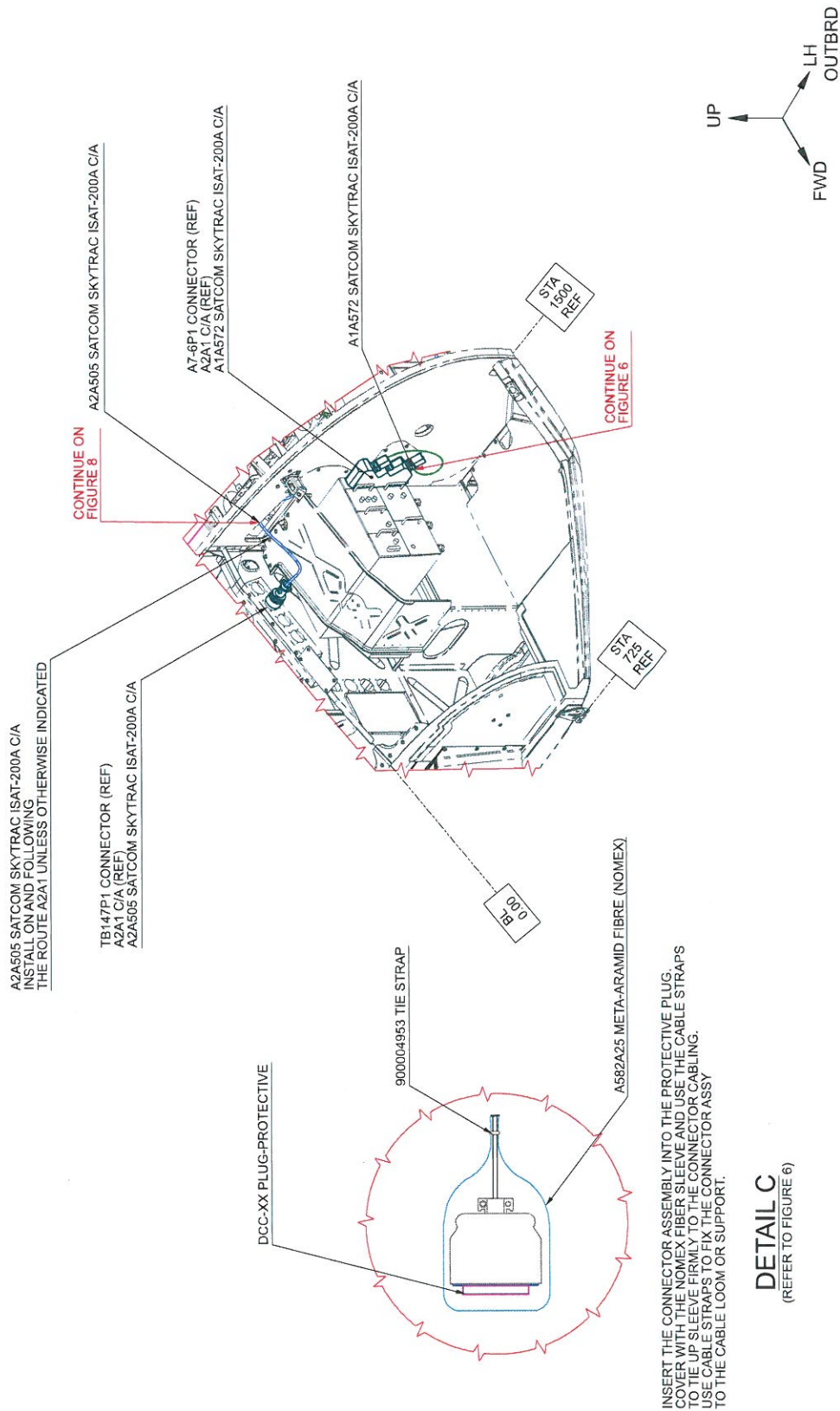
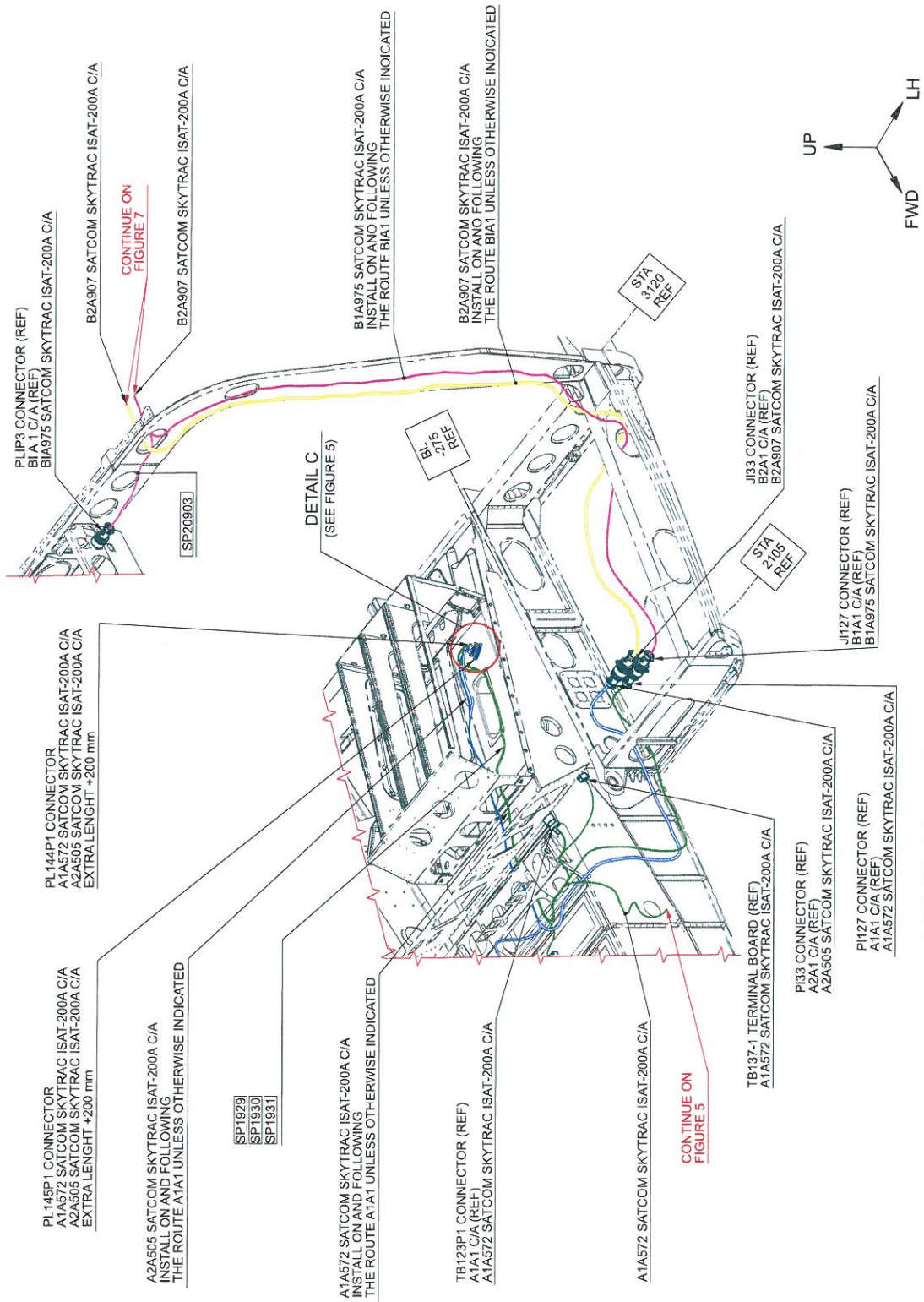

Figure 5



VIEW LOOKING LEFT COCKPIT AND PEDESTAL

PARTS OMITTED FOR BETTER CLARITY PURPOSE

Figure 6

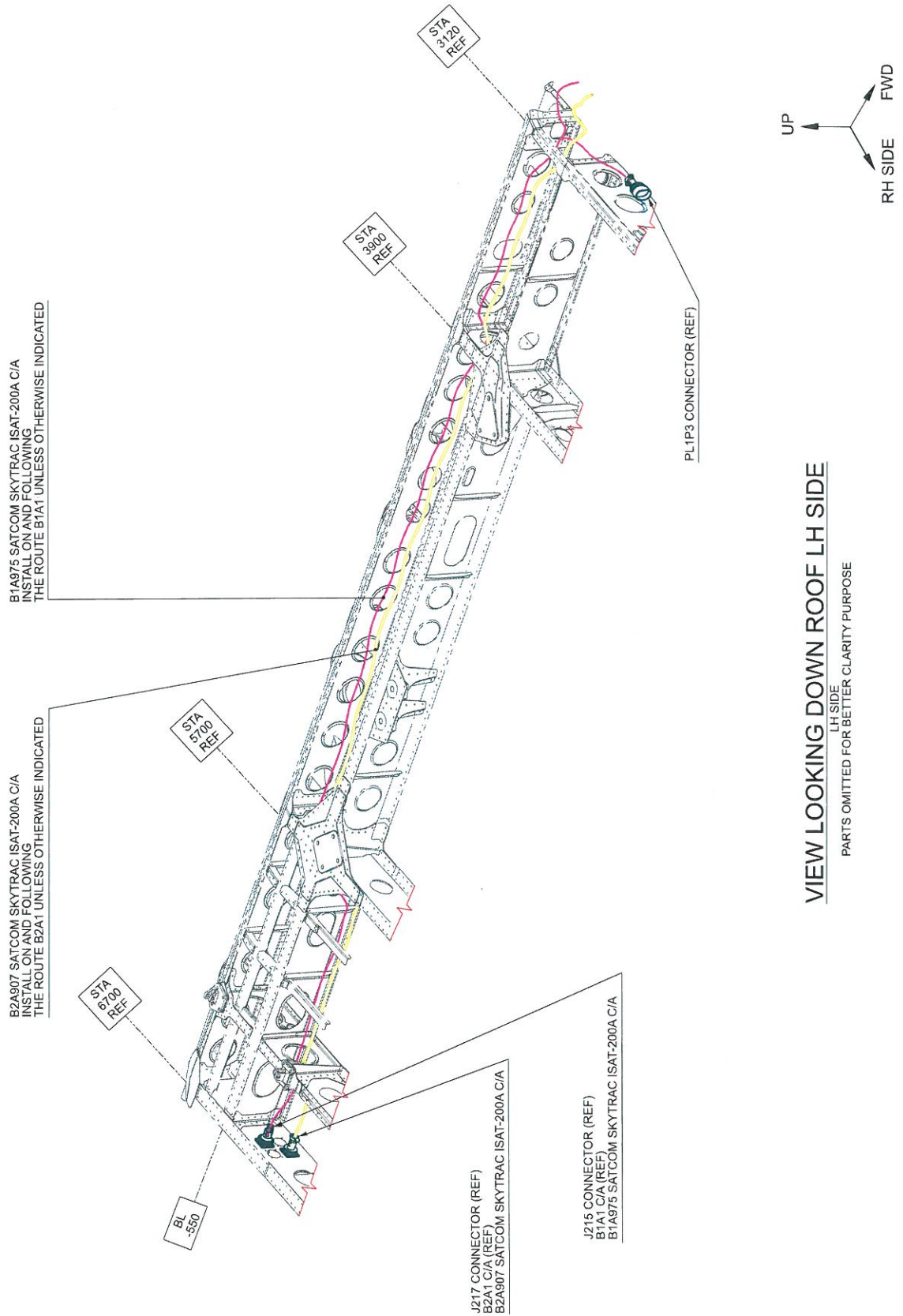

Figure 7

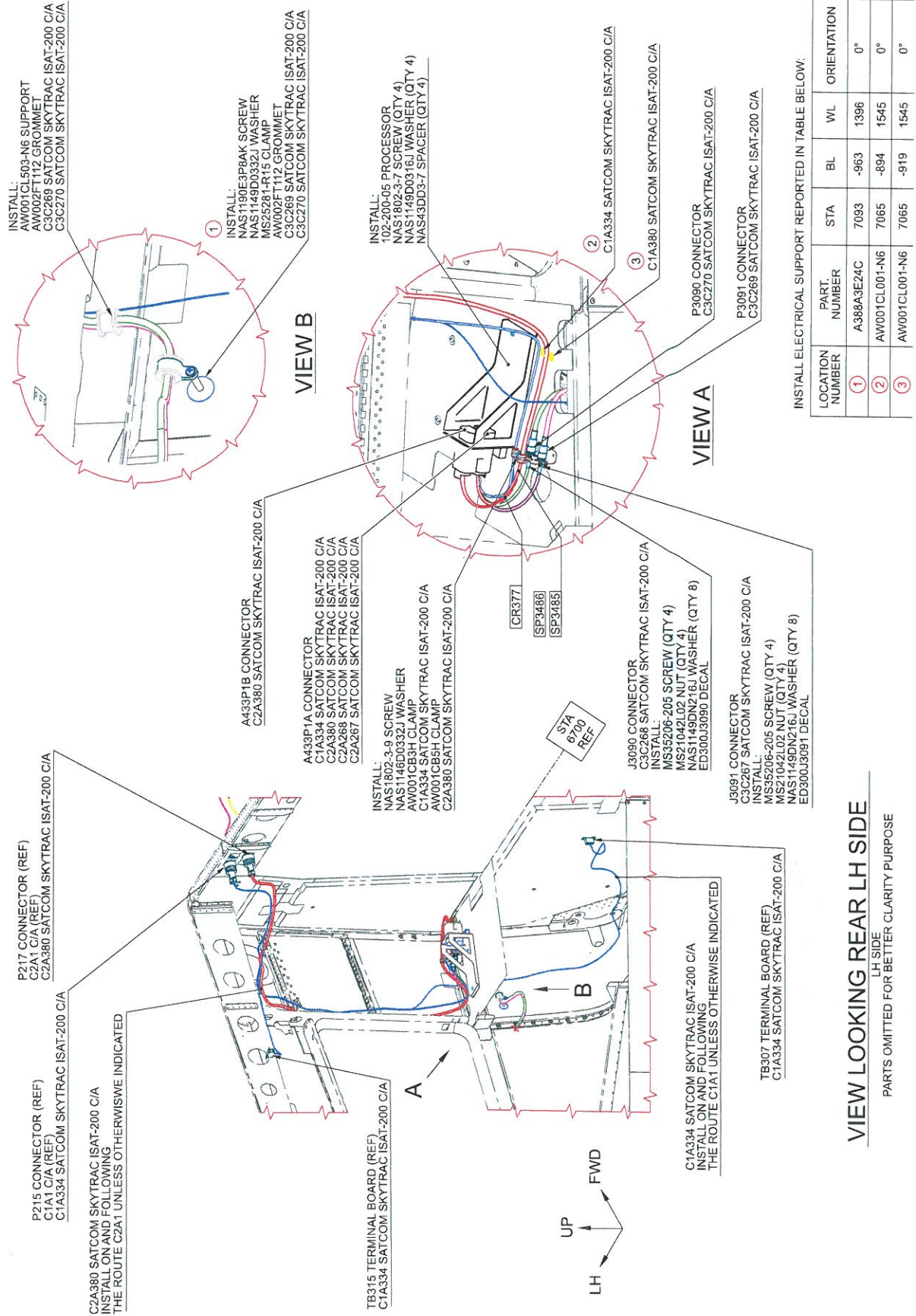
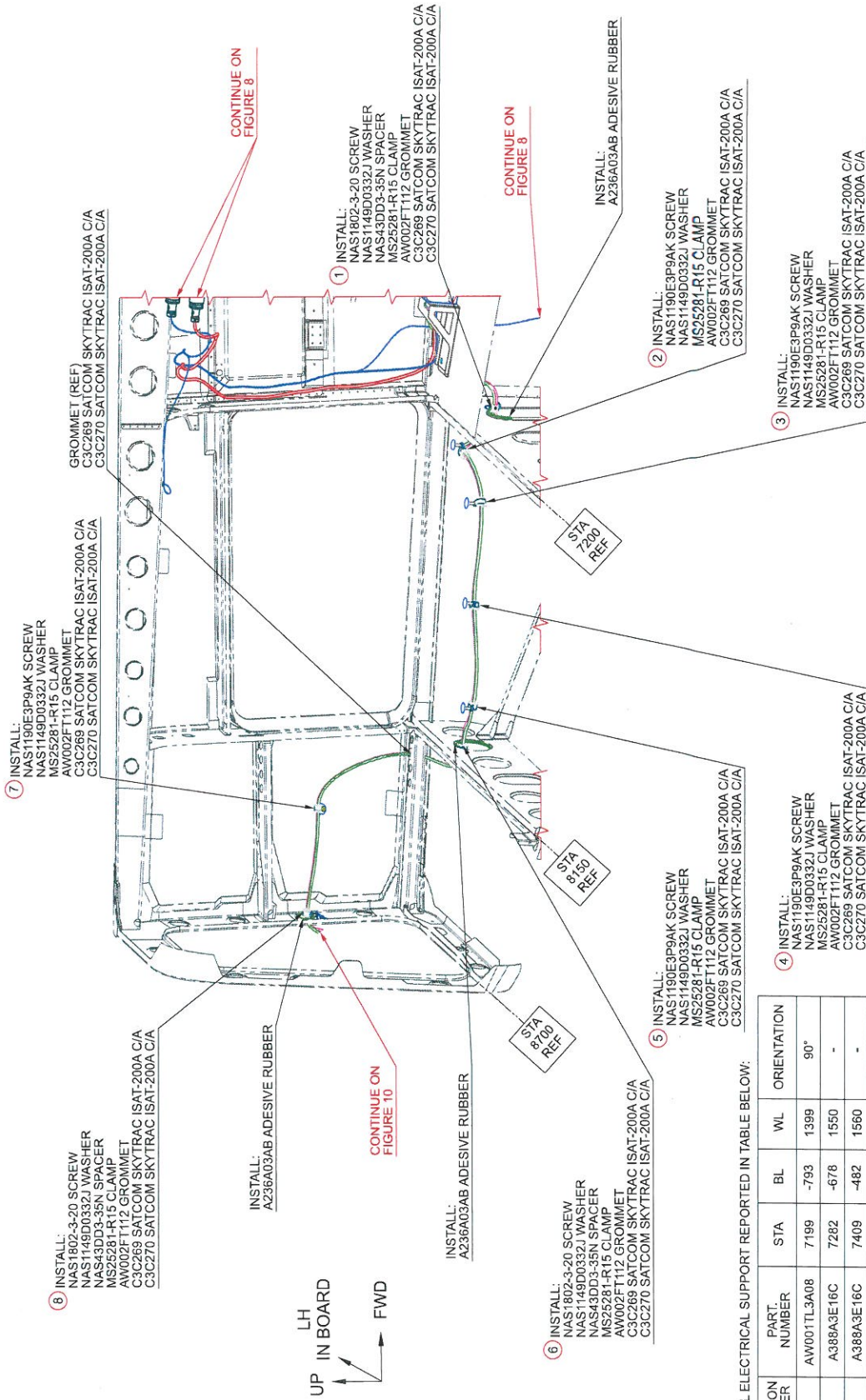

Figure 8

VIEW LOOKING REAR LH SIDE
LH SIDE

PARTS OMITTED FOR BETTER CLARITY PURPOSE



VIEW LKG REAR FUSELAGE LH SIDE
PARTS OMITTED FOR BETTER CLARITY PURPOSE

INSTALL ELECTRICAL SUPPORT REPORTED IN TABLE BELOW:

LOCATION NUMBER	PART. NUMBER	STA	BL	WL	ORIENTATION
1	AW001TL3A08	7199	-793	1399	90°
2	A388A3E16C	7282	-678	1550	-
3	A388A3E16C	7409	-482	1560	-
4	A388A3E16C	7689	-350	1581	-
5	A388A3E16C	7965	-214	1603	-
6	AW001TL3A06	8151	-360	1582	180°
7	A388A3E06C	8394	-491	1929	-
8	AW001TL3A06	8699	-325	1946	0°

Figure 9

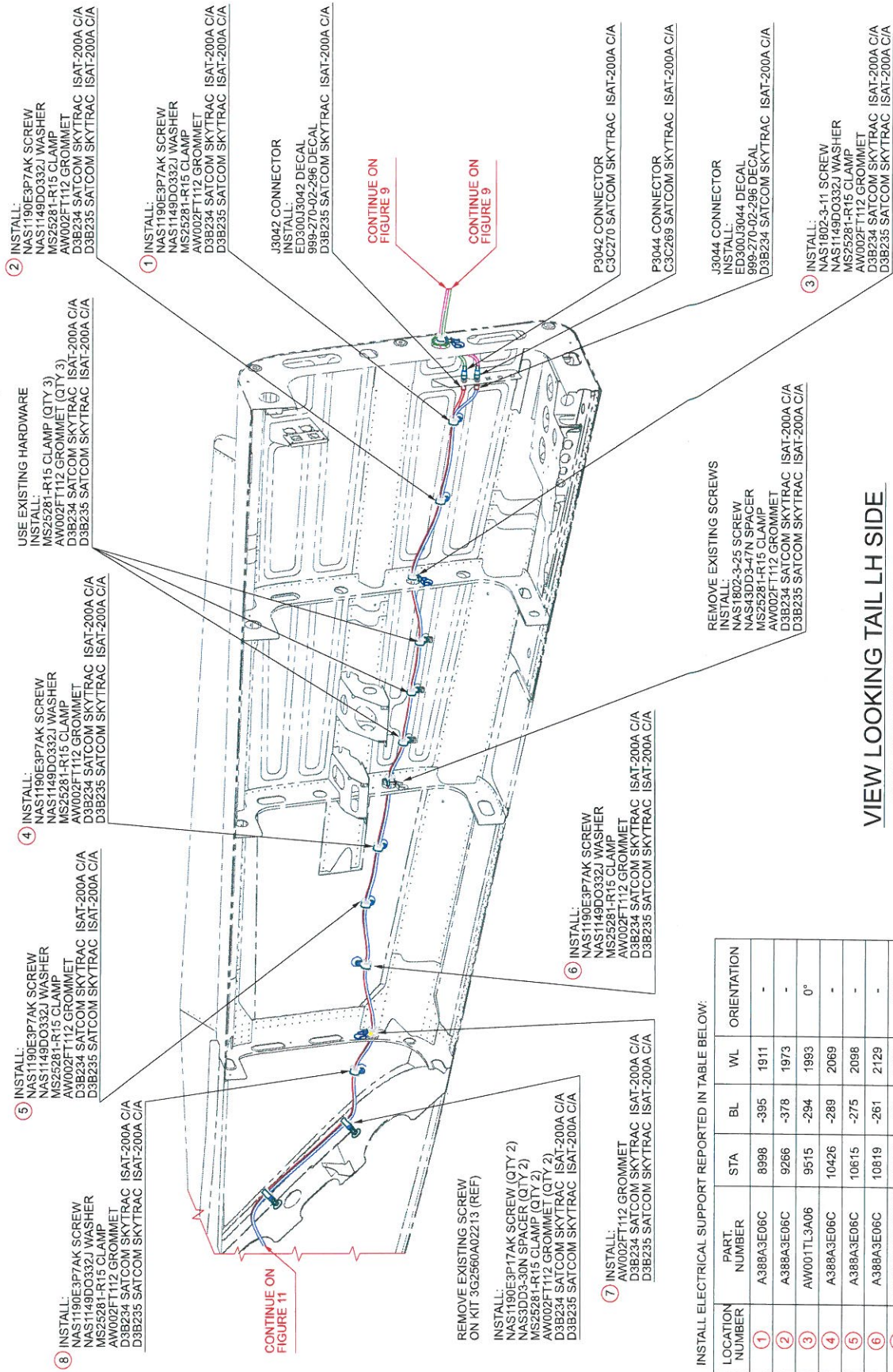

VIEW LOOKING TAIL LH SIDE
PARTS OMITTED FOR BETTER CLARITY PURPOSE

INSTALL ELECTRICAL SUPPORT REPORTED IN TABLE BELOW:

LOCATION NUMBER	PART NUMBER	STA	BL	WL	ORIENTATION
1	A388A3E06C	8998	-395	1911	-
2	A388A3E06C	9266	-378	1973	-
3	AW001TL3A06	9515	-294	1993	0°
4	A388A3E06C	10426	-289	2069	-
5	A388A3E06C	10615	-275	2098	-
6	A388A3E06C	10619	-261	2129	-
7	AW001CL005C01-X1	11060	-220	2112	180°
8	A388A3E06C	1182	-234	2094	-

Figure 10

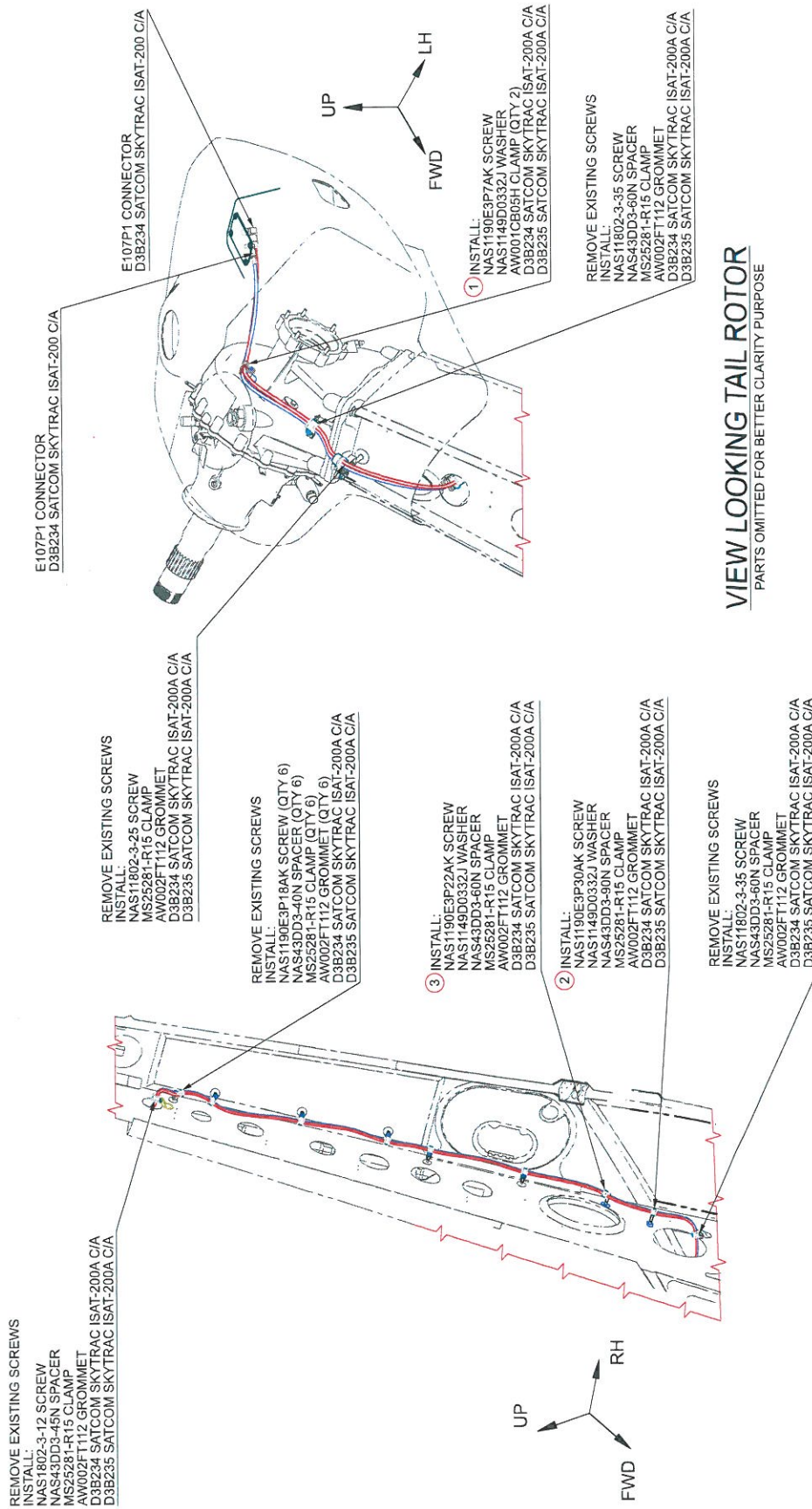

VIEW LOOKING TAIL ROTOR
PARTS OMITTED FOR BETTER CLARITY PURPOSE

VIEW LOOKING VERTICAL TAIL FIN
PARTS OMITTED FOR BETTER CLARITY PURPOSE

INSTALL ELECTRICAL SUPPORT REPORTED IN TABLE BELOW:

LOCATION NUMBER	PART. NUMBER	STA	BL	WL	ORIENTATION
①	A388A3E10C	13372	-28	4081	-
②	A388A3E08C75	11790	60	2524	0°
③	A388A3E08C75	11901	115	2633	150°

Figure 11

**SAT/COM ISAT-200
EQUIPMENT INSTALLATION**

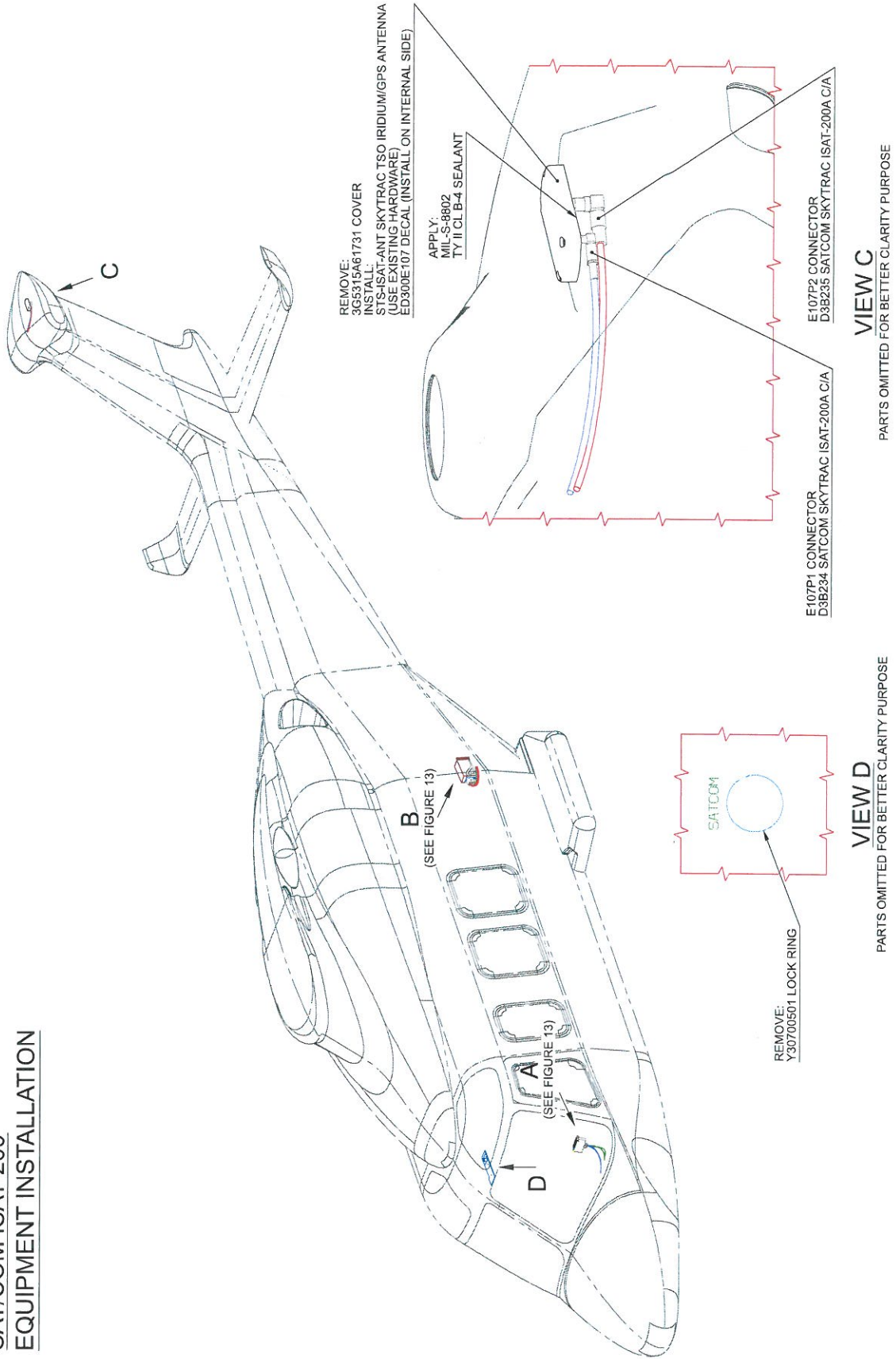

Figure 12

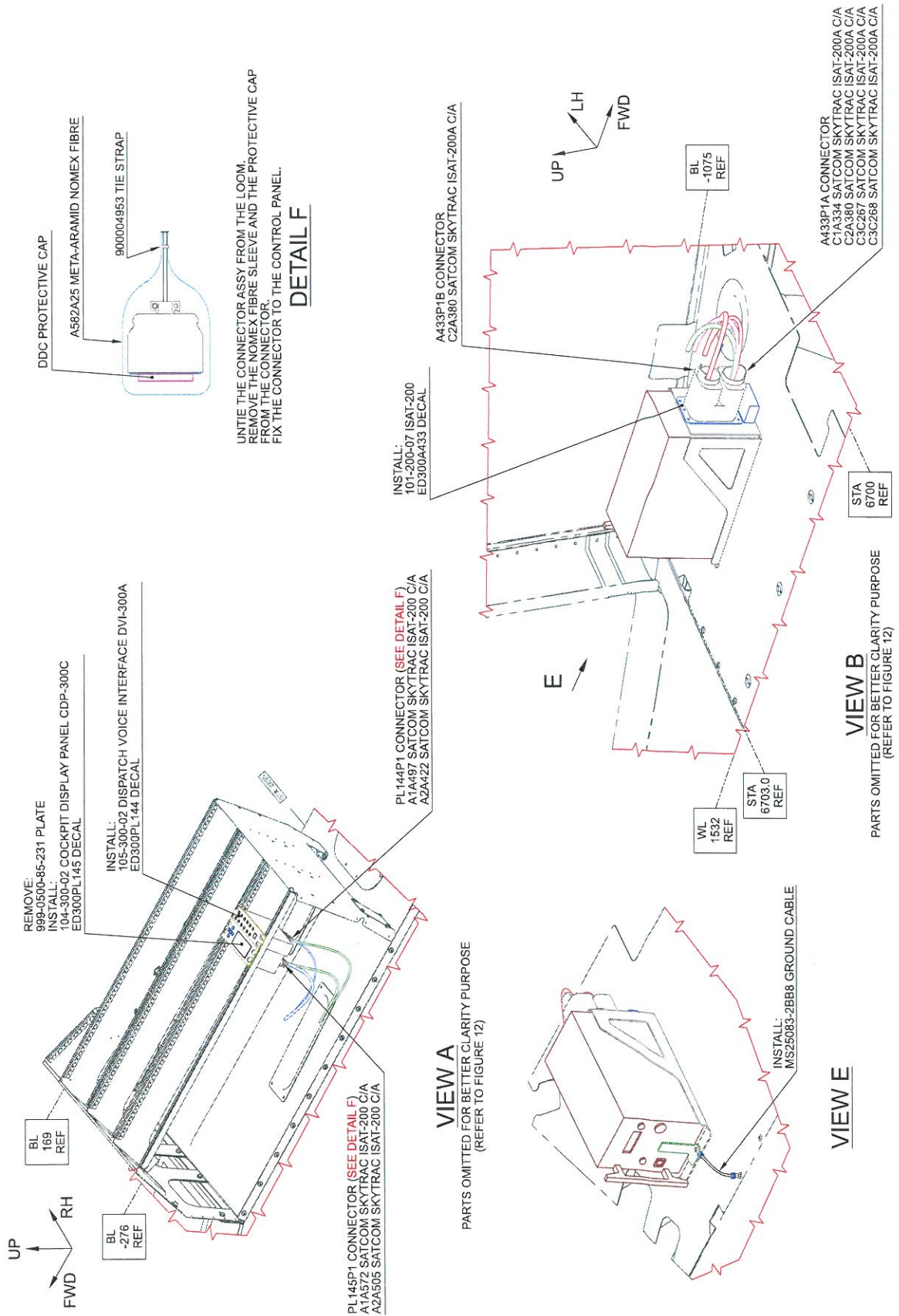
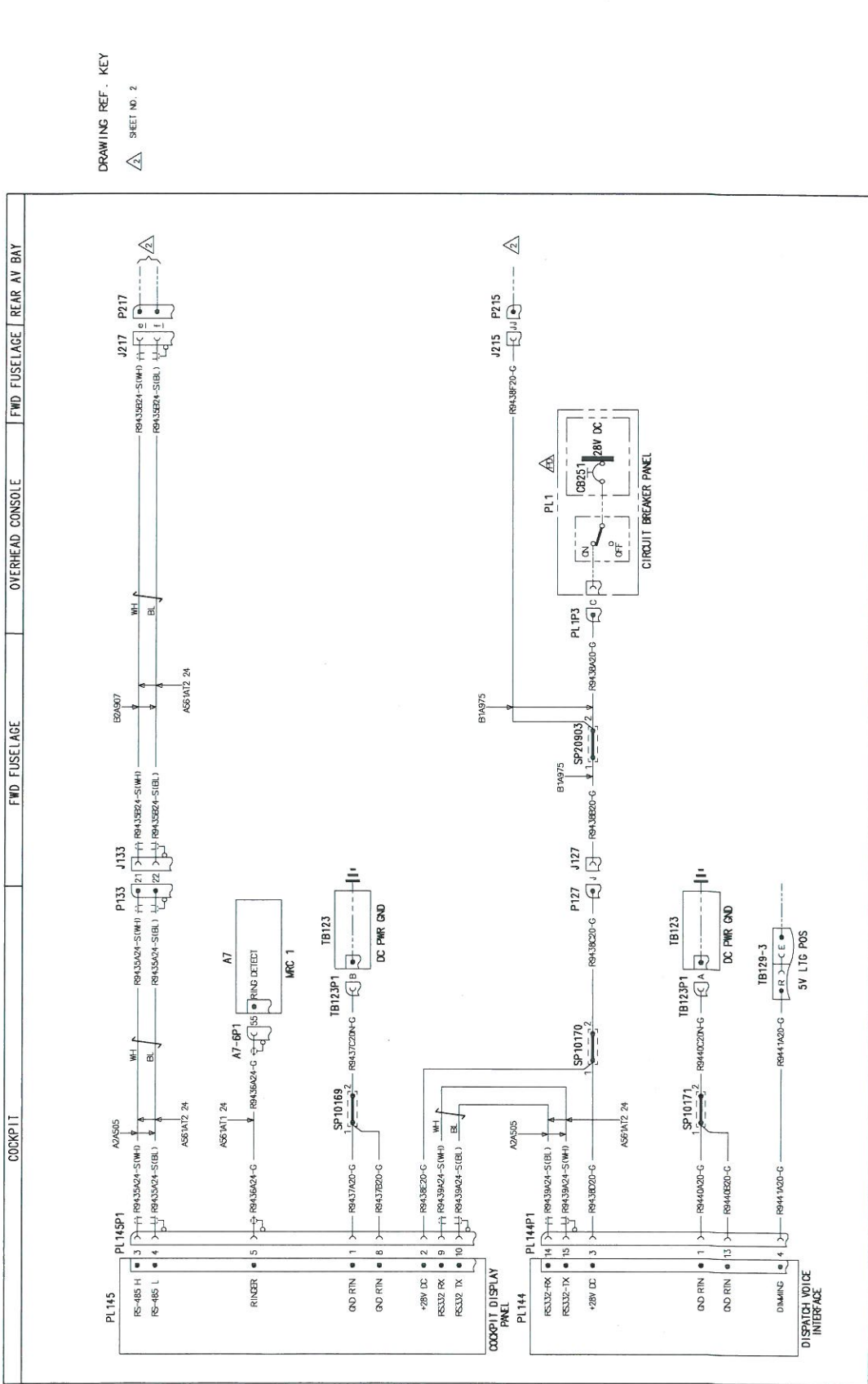

Figure 13



DRAWING REF. KEY
 SHEET NO. 2

3G4390W03011
WIRING DIAGRAM SAT/COM ISAT-200
 SHEET 1

FUNCTIONAL NOTES
 ALL CABLES ARE IN LOOM A14577 UNLESS SPECIFIED
 ALL CABLES ARE OF TYPE ASSIAT 20 UNLESS SPECIFIED

Figure 14

S.B. N°139-624
 DATE: March 18, 2022
 REVISION: /

DRAWING REF. KEY
△ SHEET NO. 1

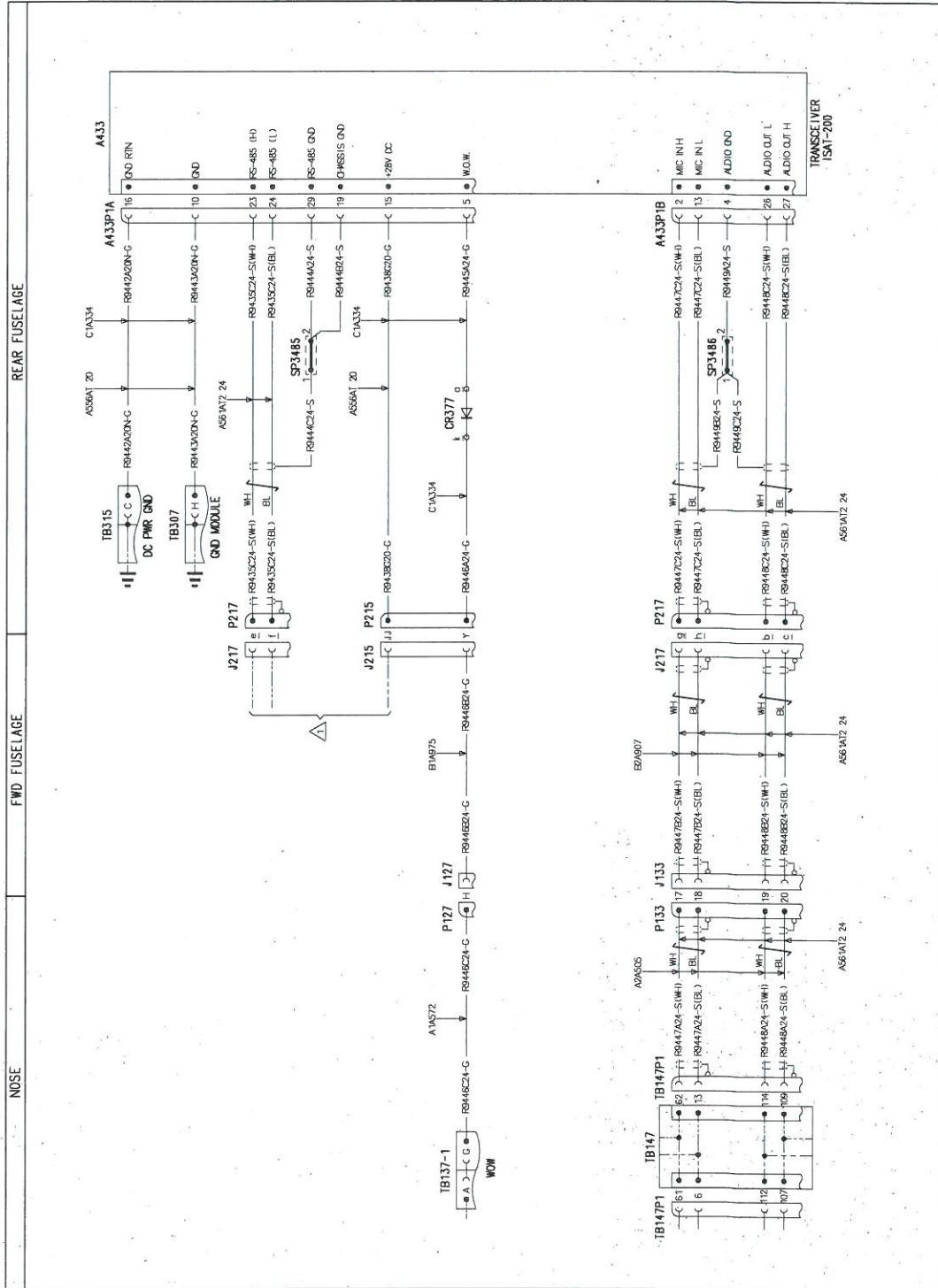

FUNCTIONAL NOTES
ALL CABLES ARE IN LOOM C2A390 UNLESS SPECIFIED
ALL CABLES ARE OF TYPE ASS6AT 24 UNLESS SPECIFIED

Figure 15

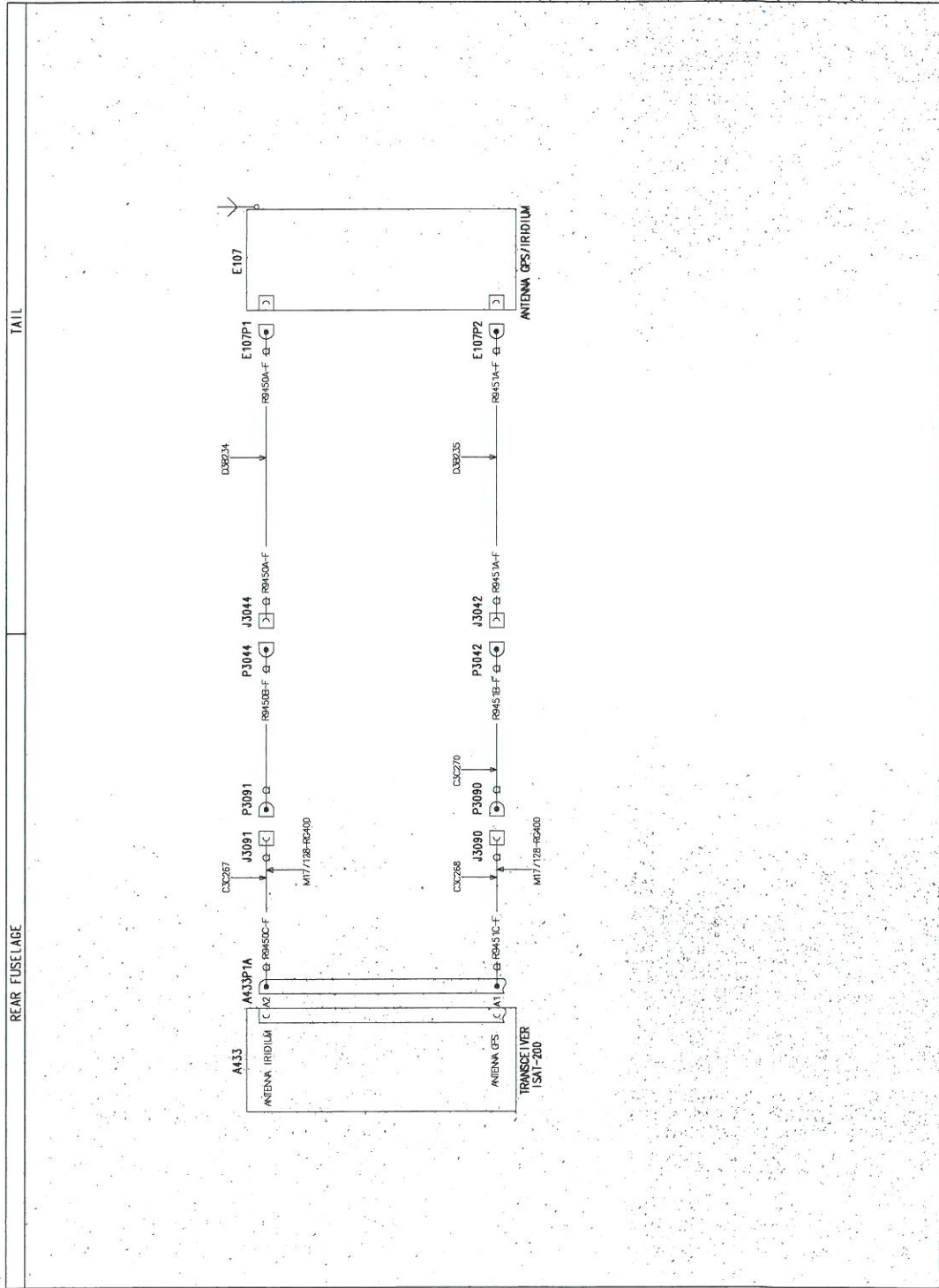

3G4390W03011
WIRING DIAGRAM SAT/COM ISAT-200
SHEET 3

FUNCTIONAL NOTES
ALL CABLES ARE IN UDM 650010 UNLESS SPECIFIED
ALL CABLES ARE OF TYPE 553122 UNLESS SPECIFIED

Figure 16

Please send to the following address: LEONARDO S.p.A. CUSTOMER SUPPORT & SERVICES - ITALY PRODUCT SUPPORT ENGINEERING & LICENSES DEPT. Via Giovanni Agusta, 520 21017 Cascina Costa di Samarate (VA) - ITALY Tel.: +39 0331 225036 Fax: +39 0331 225988		SERVICE BULLETIN COMPLIANCE FORM		Date:
		Number:		
		Revision:		
Customer Name and Address:			Telephone:	
			Fax:	
			B.T. Compliance Date:	
Helicopter Model	S/N	Total Number	Total Hours	T.S.O.
Remarks:				
Information: We request your cooperation in filling this form, in order to keep out statistical data relevant to aircraft configuration up-to-date. The form should be filled in all its parts and sent to the above address or you can communicate the application also via Technical Bulletin Application Communication Section placed in Leonardo AW Customer Portal - MyCommunications Area. We thank you beforehand for the information given.				