



(F6177)

26 quai Charles Pasqua - 92300 Levallois-Perret - France
Tél. +33 1 58 63 16 90 - Fax: +33 1 58 63 16 18

MAINTENANCE MANUAL WITH ILLUSTRATED PARTS LIST

AIRCRAFT BATTERY

170CH-1

P/N: 413652

date of creation: Oct 15/1998

24-33-98

edition 1
Jul 21/2023



**Component Maintenance Manual
170CH-1**

This document and all information contained herein are the property of Saft. Its use is restricted solely to the maintenance of Saft batteries and may under no circumstances be used for any other manufacturer's products. No person may, in whole or in part, duplicate, use or disclose this information for any other purpose without the prior written consent of Saft.



Component Maintenance Manual
170CH-1

RECORD OF REVISIONS

Rev. n°	Issue date	Inserted		Rev. n°	Issue date	Inserted	
		Date	By			Date	By
0	Oct 15/1998	Oct 15/1998	Saft				
1	Jul 21/2023	Jul 21/2023	Saft				



**Component Maintenance Manual
170CH-1**

PAGE INTENTIONALLY LEFT BLANK

RECORD OF TEMPORARY REVISIONS

Rev. n°	Issue date	Inserted		Rev. n°	Issue date	Inserted	
		Date	By			Date	By



**Component Maintenance Manual
170CH-1**

PAGE INTENTIONALLY LEFT BLANK

SERVICE BULLETIN LIST

Service bulletin		Incorporation into CMM		Title
Number	Rev.	Date	Rev.	



**Component Maintenance Manual
170CH-1**

PAGE INTENTIONALLY LEFT BLANK

LIST OF EFFECTIVE PAGES

TITLE PAGE		Jul 21/2023	DESCRIPTION AND	1	Jul 21/2023
	T-2	Jul 21/2023	OPERATION	2	Jul 21/2023
				3	Jul 21/2023
RECORD	ROR-1	Jul 21/2023		4	Blank
OF REVISIONS	ROR-2	Blank			
			TESTING AND FAULT	1001	Jul 21/2023
RECORD OF TEMPO-	RTR-1	Jul 21/2023	ISOLATION	1002	Jul 21/2023
RARY REVISIONS	RTR-2	Blank		1003	Jul 21/2023
				1004	Blank
SERVICE BULLETIN	SBL-1	Jul 21/2023			
LIST	SBL-2	Blank	DISASSEMBLY	3001	Jul 21/2023
				3002	Jul 21/2023
LIST OF EFFECTIVE	LEP-1	Jul 21/2023			
PAGES	LEP-2	Jul 21/2023	CLEANING	4001	Jul 21/2023
				4002	Jul 21/2023
TABLE OF CON-	TOC-1	Jul 21/2023			
TENTS	TOC-2	Jul 21/2023			
	TOC-3	Jul 21/2023			
	TOC-4	Blank			
LIST OF ILLUSTR-	LOI-1	Jul 21/2023			
ACTIONS	LOI-2	Blank			
INTRODUCTION	Intro-1	Jul 21/2023			
	Intro-2	Jul 21/2023			
	Intro-3	Jul 21/2023			
	Intro-4	Jul 21/2023			
	Intro-5	Jul 21/2023			
	Intro-6	Blank			

Component Maintenance Manual 170CH-1

INSPECTION/CHECK	5001	Jul 21/2023	ILLUSTRATED	10001	Jul 21/2023
	5002	Jul 21/2023	PARTS LIST	10002	Jul 21/2023
	5003	Jul 21/2023		10003	Jul 21/2023
	5004	Jul 21/2023		10004	Jul 21/2023
	5005	Jul 21/2023		10005	Jul 21/2023
	5006	Jul 21/2023		10006	Jul 21/2023
	5007	Jul 21/2023			
	5008	Jul 21/2023	STORAGE	15001	Jul 21/2023
	5009	Jul 21/2023	(INCLUDING	15002	Jul 21/2023
	5010	Jul 21/2023	TRANSPORTATION)	15003	Jul 21/2023
				15004	Jul 21/2023
ASSEMBLY	7001	Jul 21/2023			
	7002	Jul 21/2023			
	7003	Jul 21/2023			
	7004	Jul 21/2023			
	7005	Jul 21/2023			
	7006	Jul 21/2023			
	7007	Jul 21/2023			
	7008	Jul 21/2023			
FITS AND CLEARANCES	8001	Jul 21/2023			
	8002	Blank			
SPECIAL TOOLS, FIXTURES, EQUIPMENT AND CONSUMABLES	9001	Jul 21/2023			
	9002	Jul 21/2023			

TABLE OF CONTENTS

RECORD OF REVISIONS	ROR-1
RECORD OF TEMPORARY REVISIONS	RTR-1
SERVICE BULLETIN LIST	SBL-1
LIST OF EFFECTIVE PAGES	LEP-1
TABLE OF CONTENTS	TOC-1
LIST OF ILLUSTRATIONS	LOI-1
INTRODUCTION	INTRO-1
1. General	-INTRO-1
2. Definitions	-INTRO-1
3. Safety	-INTRO-1
3-1. Physical	-INTRO-1
3-2. Electrical	-INTRO-1
3-3. Chemical	-INTRO-1
4. Aircraft conversions	-INTRO-2
5. Ground applications	-INTRO-2
6. Placing a new battery in service - initial commissioning	-INTRO-2
7. Battery ratings capacity	-INTRO-2
8. Recycling	-INTRO-2
9. End of life cells	-INTRO-3
10. Measurements	-INTRO-3
10-1. Units of measure	-INTRO-3
10-2. Measurement conversion table	-INTRO-4
10-3. Temperature conversion	-INTRO-5
10-4. Abbreviations	-INTRO-5
11. Verification and technical review	-INTRO-5
DESCRIPTION AND OPERATION	1
1. Overview	1
2. Technical data	1
3. Description	1
4. Operation	2
4-1. Climatic requirement	2
4-2. Maintenance	2
5. Charge	2
5-1. Constant current charge	3
5-2. Other methods of charging	3
5-3. Active standby mode (use of a trickle charge)	3
TESTING AND FAULT ISOLATION	1001
1. Introduction	-1001
2. Battery faults	-1001
2-1. Battery electrical faults	-1001
2-2. Cell faults	-1002
2-3. Physical faults	-1003

DISASSEMBLY - - - - - 3001

1. Introduction	-3001
1-1. General	-3001
1-2. Safety	-3001
1-3. Job set-up information	-3001
2. Disassembly of the battery	-3001
2-1. Removal of the cover complete	-3001
2-2. Removal of the cells	-3001
2-3. Removal of the liner-spacer kit	-3001
2-4. Removal of the power connector complete	-3002
2-5. Removal of the sensor connector complete	-3002
2-6. Removal of the box mounting brackets	-3002

CLEANING- - - - - 4001

1. Introduction	-4001
2. Safety	-4001
3. Equipment	-4001
3-1. Standard tools	-4001
3-2. Special tools	-4001
3-3. Consumables	-4001
4. Light cleaning	-4001
4-1. Procedure	-4001
5. Thorough cleaning	-4001
5-1. Procedure	-4001
5-2. Lubrication	-4002

INSPECTION/CHECK - - - - - 5001

1. Introduction	-5001
2. Maintenance intervals	-5001
2-1. Periodical check	-5001
2-2. Regular check	-5001
2-3. General overhaul	-5001
3. Recording	-5001
4. Safety	-5001
5. Equipment	-5001
5-1. Standard tools	-5001
5-2. Special tools	-5001
6. Periodical check	-5002
6-1. Visual inspection	-5003
6-2. Insulation check	-5003
6-3. Nut tightness	-5004
6-4. Open circuit voltage check	-5004
6-5. Polarization test	-5004
6-6. Residual discharge	-5004
6-7. Adjust electrolyte level	-5004
6-8. Supplementary test	-5005
7. Regular check	-5006
7-1. Cell shorting	-5007
7-2. Capacity check	-5007
8. General overhaul	-5008
8-1. Component inspection	-5009
8-2. Replacement of faulty components	-5009
8-3. Sensor connector check	-5009
8-4. Vent-valve test	-5010

ASSEMBLY	7001
1. Introduction	-7001
2. Safety	-7001
3. Equipment	-7001
3-1. Standard tools	-7001
3-2. Special tools	-7001
4. Battery assembly	-7001
4-1. Installation of the sensor connector complete	-7001
4-2. Construction and installation of the power connector	-7004
4-3. Installation of the liner-spacer kit	-7005
4-4. Installation of the cell assemblies	-7007
4-5. Installation of the box mounting brackets	-7008
4-6. Recording	-7008
FITS AND CLEARANCES	8001
1. Introduction	-8001
2. Torque table	-8001
SPECIAL TOOLS, FIXTURES, EQUIPMENT AND CONSUMABLES	9001
1. Introduction	-9001
2. Standard tools	-9001
3. Special tools	-9001
4. Consumables	-9002
ILLUSTRATED PARTS LIST	10001
1. Introduction	-10001
1-1. General	-10001
1-2. Alpha numerical index	-10001
1-3. Detailed parts list	-10001
2. Alpha numerical index	-10002
3. Detailed part list	-10004
STORAGE (INCLUDING TRANSPORTATION)	15001
1. Introduction	-15001
1-1. General	-15001
1-2. Storage room	-15001
1-3. Climatic conditions	-15001
2. Storage	-15001
2-1. Inactive long-term storage	-15001
2-2. Inactive standby storage	-15001
3. Storage of spare parts	-15004
3-1. Spare cell assemblies	-15004
3-2. Spare O-rings, gaskets, and vent-valves assemblies	-15004
4. Transportation procedure	-15004



**Component Maintenance Manual
170CH-1**

PAGE INTENTIONALLY LEFT BLANK

LIST OF ILLUSTRATIONS

Figure INTRO-1 - Universal recycling symbols - - - - -	Page INTRO-2
Figure 1 - 170CH-1 Nickel-Cadmium aircraft battery - - - - -	Page 2
Figure 5001 - Periodical check - - - - -	Page 5002
Figure 5002 - Position of syringe in cell vent seat - - - - -	Page 5005
Figure 5003 - Regular check - - - - -	Page 5006
Figure 5004 - General overhaul - - - - -	Page 5008
Figure 7001 - Sensor connector complete - - - - -	Page 7001
Figure 7002 - Sensor connector wire layout - - - - -	Page 7002
Figure 7003 - Sensor connector wire layout details - - - - -	Page 7003
Figure 7004 - Liner-spacer kit - - - - -	Page 7005
Figure 7005 - Battery layout - - - - -	Page 7007
Figure IPL-1 - 170CH-1 Nickel-Cadmium Aircraft Battery - - - - -	Page 10004
Figure 15001 - Standby storage period - - - - -	Page 15002
Figure 15002 - Inactive standby storage - - - - -	Page 15003



**Component Maintenance Manual
170CH-1**

PAGE INTENTIONALLY LEFT BLANK

INTRODUCTION

1. General

This manual provides the information necessary for an experienced shop technician to maintain Saft nickel-cadmium batteries. It describes the construction of the battery as well as the techniques used to operate, maintain, overhaul, and generally care for the battery. Following these instructions will make sure of optimal performances and life of the Saft batteries.

All aircraft batteries require checking and maintenance in order to make sure they are safe when installed and perform their required functions, especially in emergency conditions on board the aircraft. Maintenance permit to identify and correct any issues to be identified. Proper battery maintenance assures a low probability of failure. It achieves high levels of MTBUR and MTBF. Failure prevention on board the aircraft make sure of safe operation, reduces delays and operational costs.

Every effort has been made to provide complete and accurate instructions. If a situation should arise that is not adequately described in this manual, please contact Saft via the Internet at www.saft.com or at one of the following addresses:

Saft America Inc. (09052)
711 Gil Harbin Industrial Boulevard
Valdosta, Georgia 31601 - USA
Tel: +1 (229) 247-2331
Fax: +1 (229) 247-8486

Saft (F6177)
26 quai Charles Pasqua
92300 Levallois-Perret - France
Tel: +33 1 58 63 16 00
fax: +33 1 58 63 16 18

Website All Saft technical documentation, distributors and repair shops can be found at <https://saft4u.saft.com>.

2. Definitions

WARNING: WARNINGS ADVISE TO USE OF MATERIALS, PROCEDURES, OR LIMITS, WHICH MUST BE FOLLOWED PRECISELY TO AVOID PERSONAL INJURIES, OR EFFECT SAFETY OF FLIGHT.

CAUTION: CAUTIONS CALL ATTENTION TO PROCEDURES WHICH MUST BE FOLLOWED TO AVOID DAMAGE TO EQUIPMENT OR PARTS.

NOTE: NOTES call attention to procedures which make the job easier.

3. Safety

WARNING: EXCEPT FOR THOSE STEPS THAT REQUIRE THE BATTERY TO BE CHARGED, DO ALL STEPS ON DISCHARGED BATTERIES (REFER TO [Residual discharge](#) PARAGRAPH) TO AVOID THE POSSIBILITY OF ELECTRIC SHOCK. TIGHTEN VENT-VALVES BEFORE THE START OF THE DISCHARGE. BATTERY CELLS DELIVER VERY HIGH CURRENT WHEN SHORT-CIRCUITED. BE CAREFUL. REMOVE RINGS, WATCHES, NECKLACES, METALLIC BELTS OR OTHER JEWELRY TO AVOID ELECTRIC SHOCK.

WARNING: DO NOT TILT THE BATTERY WHILE DOING MAINTENANCE, ANY CONTACT OF SKIN WITH ELECTROLYTE CAN CAUSE SEVERE BURNS.

Local safety regulations should be followed as safety regulations are country-dependent

There are three types of risks:

3-1. Physical

- Handling: the battery is heavy. Use proper technique when lifting heavy loads. Bend your legs and not your back
- Wear protective shoes

3-2. Electrical

- Do not wear rings, watches, chains, belt buckles, necklaces or any other conductive objects
- Use insulated tools

3-3. Chemical

- For a complete listing of hazards, refer to the Battery Information Sheet (BIS) available on Saft's website at <https://saft4u.saft.com>
- Electrolyte is very corrosive and can damage the skin. Use proper personal protective equipment (PPE) such as gloves and an apron. If it touches the skin, flush affected area with large quantities of water. After flushing begins, remove all contaminated clothing.
- Electrolyte is very dangerous to the eyes, use protective goggles. If the electrolyte comes in contact with the eyes, flush with water for 15 to 30 minutes and get immediate medical aid.
- Saft recommends the use of an amphoteric solution (both acidic and basic behavior) and chelator (able to trap cations as a chelate complex) to neutralize electrolyte according to the local regulation.

- Electrolyte ingestion can cause damage to the throat and the respiratory tract. Do not try to vomit. Get medical aid immediately.
- Skin contact with nickel can cause chronic eczema.
- Inhalation of cadmium oxide can cause dry throat, headaches, vomiting, chest pain, and difficulties breathing. If inhaled, get fresh air. If stops breathing, give artificial respiration. If breathing becomes difficult, give oxygen. Get medical aid immediately.
- Potassium hydroxide in the electrolyte can cause eczema.

4. Aircraft conversions

Saft aircraft batteries come in a wide variety of configurations that are approved for installation on selected aircraft. When replacing a lead-acid battery with a Saft nickel-cadmium aircraft battery, it is vitally important to clean all mounting and holding fixtures in the aircraft before installation. All traces of acid and salt should be removed by washing with a neutralizing agent such as sodium bicarbonate (baking soda) in water. When the area has been fully cleaned and prepared, paint the surface with an alkaline resistant paint. This preparation makes sure that your new Saft battery will not be harmed by sulfuric acid residue.

5. Ground applications

Saft batteries can be used in ground applications for starting gas turbine generators, powering ground mobile equipment, or in shop testing equipment. The same principles used in flight operations apply when the battery is used in ground applications. Ventilation of the battery during ground use can be accomplished through a ventilation system or by simply removing the cover (only in a well-ventilated area). Check with your local authorities for regulations in effect.

6. Placing a new battery in service - initial commissioning

NOTE: Whether or not the battery has been subject to disassembly and reassembly, before to issue in service and installation certificate, check the tightness of all upper nuts to verify that torque values correspond with those specified (refer to chapter [Nut tightness](#)).

Before installation of the battery into the aircraft for service:

- If initial commissioning is performed within 12 months then do [Visual inspection](#), [Insulation check](#), [Nut tightness](#), [Charge Adjust electrolyte level](#), and repeat [Insulation check](#).
- If initial commissioning is performed after 12 months, do [Charge](#) and [Regular check](#).

Starting date for this period is the date of manufacturing (DMF)

7. Battery ratings capacity

Nickel-cadmium batteries are rated in terms of capacity in ampere-hours (Ah) (rated capacity)

American Standard AS8033 defines capacity as "the dis-chargeable ampere-hours (Ah) available from a fully charged cell/battery at any specified discharge rate/temperature condition"

Other definitions for battery ratings can be found in EN2570, IEC 60952 and RTCA DO 293

A battery rated for $1C_1$ Ah indicates that the battery is rated at a value based upon a discharge time of 1 hour at $+23\text{ }^\circ\text{C} \pm 3\text{ }^\circ\text{C}$ ($+73.4\text{ }^\circ\text{F} \pm 5.4\text{ }^\circ\text{F}$)

8. Recycling

All batteries eventually lose their ability to perform and are eligible for scrapping and recycling. Saft takes environmental matters seriously and advocates proper recycling of nickel-cadmium batteries and their components. To that end, Saft operates recycling facilities worldwide.

Nickel-cadmium batteries contain nickel, cadmium, and potassium hydroxide and should be disposed of properly. In all cases, rely on local and national regulations for proper battery disposal and/or shipping to an appropriate recycling location.

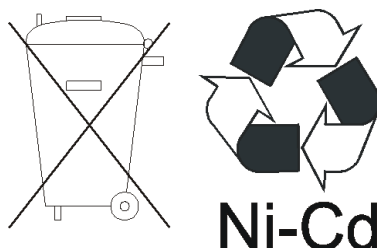

Figure INTRO-1 - Universal recycling symbols

You can find the nearest recycling collection point on our website at <https://www.saft.com/about-us/manufacturing-our-batteries/our-sustainability-global-approach>.

9. End of life cells

EASA and FAA regulations 'Part 145', require that end of life cells must be disposed of in a manner that does not allow them to be returned to service. The following procedure provides a means to comply with these regulations.

While other authority requirements may be less explicit, Saft recommends that the following procedures be adopted in order to make sure that end of life cells cannot be re-used:

- Make sure that appropriate protective measures (refer to [Safety](#) paragraph and the BIS) are taken.
- Make sure that the cell(s) is (are) fully discharged (refer to [Cell shorting](#) paragraph)
- Break or cut the terminals. In the event of electrolyte leakage, make sure that appropriate spill clean up measures are observed as described in the BIS.
- Individually bag each cell in a liquid proof bag and dispose of the cell in accordance with applicable transport, health and safety and recycling regulations (Refer to [Recycling](#) paragraph).

10. Measurements

The measurements given in this manual come from the original manufacturer drawings.

This CMM uses the International System (SI) of units for quantities and values. Additionally US Imperial units are given in parenthesis.

10-1. Units of measure

10-1-1. SI Units

A	Ampere
Ah	Ampere hours
Bar	Bar
C ₁ A	Rated current
C ₁ Ah	Rated capacity for an hour
g	Gram
h	Hour
L	Liter
m	Meter
min	Minute
N	Newton
N.m	Newton meter
Pa	Pascal
V _{DC}	Volt direct current
°C	Degree Celsius
%	Per cent
Ω	Ohm
μS/cm	Micro-Siemens per centimeter

10-1-2. US Imperial Units

ft	Foot
in	Inch
in.Hg	Inch of Mercury
lb	Pound
lbf	Pound force
lbf.in	Pound force inch
lbf.ft	Pound force foot
oz	Ounce
psi	Pound per square inch
°F	Degree Fahrenheit

10-1-3. Multiplying prefixes

c	Centi
da	Deca
h	Hecto
k	Kilo
M	Mega
m	Milli
μ	Micro

10-2. Measurement conversion table

10-2-1. From SI unit to US Imperial unit

1 Bar	14.504 psi
1 cm	0.3937 in
1 cm ²	0.1550 in ²
1 cm ³	0.06 in ³
1 g	0.0353 oz
1 g/L	0.000578 oz/in ³
1 hPa	0.01450 psi
1 kg	2.2046 lb
1 kg/L	0.578 oz/in ³
1 mm	0.0394 in
1 N	0.2248 lbf
1 N.m	8.8507 lbf.in

10-2-2. From US Imperial unit to SI unit

1 gal (U.S.)	3.7854 L
1 in	2.54 cm
1 in	25,4 mm
1 in ²	6.4516 cm ²
1 in ³	16.4 cm ³
1 in.Hg	33.864 hPa
1 lb	0.4536 kg
1 lbf	4.4482 N
1 lbf.in	0.1130 N.m
1 lbf.ft	1.3558 N.m
1 oz	28.3495 g
1 oz/in ³	1,771.25 g/L
1 oz/in ³	1.771 kg/L
1 psi	68.948 hPa
1 psi	0.0689 Bar

10-3. Temperature conversion

10-3-1. From degrees Fahrenheit (°F) to degrees Celsius (°C)

Celsius = (Fahrenheit - 32) x 0.5555

10-3-2. From degrees Celsius (°C) to degrees Fahrenheit (°F)

Fahrenheit = (Celsius x 1.8) + 32

10-4. Abbreviations

The abbreviations given below are used in this manual:

APU	Auxiliary Power Unit
ASD	Aerospace and Defence Industries Association of Europe
ATA	Air Transport Association of America
BIS	Battery Information Sheet
dia.	diameter
DMF	Date of Manufacturing
EASA	European Air Safety Authority
FAA	Federal Aviation Authority
fig.	figure
IATA	International Transport Air Association
IEC	International Electrotechnical Commission
IMDG	International Maritime Dangerous Goods
ipl	illustrated parts list
max.	maximum
mfr	manufacturer
MTBF	Mean Time Between Failure
MTBUR	Mean Time Between Unscheduled Removal
n°	number
p/n	part number
para.	paragraph
PPE	Personal Protective Equipment
RTCA	Radio Technical Commission for Aeronautics
ref.	refer to
s/a	subassembly
SI	International System of Unit
V	Voltage

11. Verification and technical review

The technical content of this document has successfully passed a verification process on testing, inspection, disassembly, and assembly procedures. The supplier declares the content of this document accurate and adequate.

Testing & fault isolation & inspection / check	Verified Jun 16/2023
Disassembly	Verified Jun 16/2023
Assembly	Verified Jul 17/2023
Engineering technical review	Completed Jul 17/2023



**Component Maintenance Manual
170CH-1**

PAGE INTENTIONALLY LEFT BLANK

DESCRIPTION AND OPERATION

1. Overview

The batteries are connected to the aircraft system:

- According to the aircraft manufacturer and / or operator, to start the engine or the APU
- On the ground, to provide power before electrical power is supplied to the aircraft systems
- In flight, if a malfunction or a failure occurs in the power supply system

2. Technical data

Battery characteristics are indicated in the table below.

Technical data	Values
Type of cells	CVH175KH
Number of cells	20
Nominal voltage	24 V
Rated capacity C ₁	17 Ah
Charge or discharge current 1 C ₁	17 A
Charge current 0.5 C ₁	8.5 A
Charge current 0.1 C ₁	1.7 A
Electrolyte	Solution of KOH
Nozzle length	20 mm (0.79 in)
Consumable volume of electrolyte per cell	15 cm ³ (0.92 in ³)
Minimum end of charge voltage	1.55 V per cell
End of life criterion in %	100 %
End of life criteria in hour or minutes	1 hour
Battery maximum weight	17.3 kg (38.6 lb)
Battery terminals	Power connector according to ISO 5064/11 or MS 3509

Table 1 - Battery characteristics

3. Description

NOTE: The item numbers are those of the detailed parts list chapter (Refer to [Detailed part list](#)).

The [170CH-1](#) Saft nickel-cadmium battery consists of a box assembly ([015](#)), containing [20](#) individual cell assemblies ([120](#)) [CVH175KH](#). These cells are connected in series to provide a [24 V](#) nominal system. Individual cells are enclosed in a polyamide container that provides insulation, allowing them to be fitted side-by-side in the battery box assembly. Cells are interconnected with rigid, highly conductive, nickel-plated copper links ([090](#) to [110](#)). Each link is held in position by nuts ([130](#)) and washers ([140](#) to [170](#)) on the cells' terminals. Inside the battery box assembly ([015](#)), individual cell assemblies ([120](#)) are held in position by partitions, the liner-spacer kit ([190](#)), and a cover complete ([020](#)).

The power connector complete ([220](#)) connects the battery to the aircraft DC power.

The cover complete ([020](#)), which can be removed, is attached to the box assembly ([015](#)) by latches.

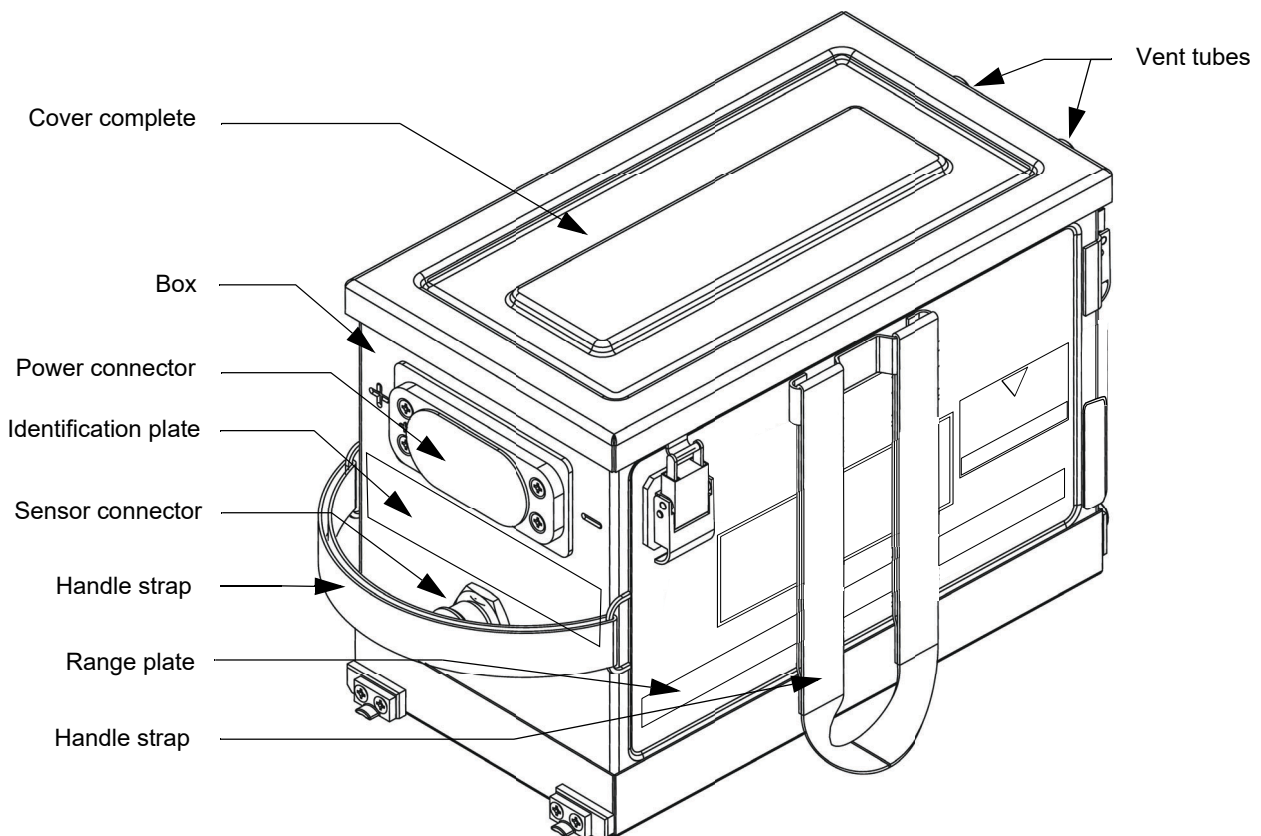

Figure 1 - 170CH-1 Nickel-Cadmium aircraft battery

4. Operation

4-1. Climatic requirement

Although Saft nickel-cadmium batteries are capable of operating in a wide temperature range $-40\text{ }^{\circ}\text{C}$ ($-40\text{ }^{\circ}\text{F}$) and $+71\text{ }^{\circ}\text{C}$ ($+160\text{ }^{\circ}\text{F}$), optimum performance is reached between $+5\text{ }^{\circ}\text{C}$ ($+41\text{ }^{\circ}\text{F}$) and $+45\text{ }^{\circ}\text{C}$ ($+113\text{ }^{\circ}\text{F}$). Charging is inefficient at temperatures below $-30\text{ }^{\circ}\text{C}$ ($-22\text{ }^{\circ}\text{F}$) and is not recommended above $+57\text{ }^{\circ}\text{C}$ ($+135\text{ }^{\circ}\text{F}$). Charging must be stopped at temperatures above $+71\text{ }^{\circ}\text{C}$ ($+160\text{ }^{\circ}\text{F}$).

Unless otherwise stated, charge and discharge testing should be done when

- The battery temperature is between $+15\text{ }^{\circ}\text{C}$ ($+59\text{ }^{\circ}\text{F}$) and $+35\text{ }^{\circ}\text{C}$ ($+95\text{ }^{\circ}\text{F}$)
- Pressure 750 to 1060 hPa (22.15 to 31.3 in.Hg)
- Relative humidity $< 85\%$.

4-2. Maintenance

All maintenance, including charging and discharging, should be done specifically in accordance with the instructions contained in this Component Maintenance Manual (CMM).

5. Charge

The charge, also called maintenance charge, is done in 2 steps:

- Step 1: called "charge" or "main charge", is a constant current charge with three possible charge rates
- Step 2: called "overcharge" or "final charge", is also a constant current charge with only one possible charge rate

5-1. Constant current charge

NOTE: Check cell voltage at the beginning of the charge. If any cell indicates an immediate voltage rise above 1.5 V, add 5 cm³ (0.3 in³) of distilled or deionized water [M01](#) to that cell.

NOTE: Always apply the main charge for no less than the minimum duration.

Starting with a discharged battery:

- Remove the cover complete ([020](#))
- Loosen, but do not remove, all vent-valve assemblies ([180](#))
- Remove power connector cover ([295](#))
- Charge using one of the methods shown in the table below (step 1) main charge
- After the minimum charge duration is reached, measure the voltage on each cell assembly ([120](#)) and compare the values with the end of (step 1) main charge criteria in table [2 - Charge rates](#)
- During the last 15-30 minutes of the (step 2) final charge cycle, [Adjust electrolyte level](#)

Charge of the battery				
(step 1) Main Charge			(step 2) Final Charge	
Current	Minimum duration	End of main charge criteria	Current and time	Minimum voltage criteria
0.1 C ₁ A* (1.7 A)	10 h	Every cell > 1.5 V or 12 h which ever comes first	1.7 A for 4 h	1.55 V per cell
0.5 C ₁ A (8.5 A)	2 h	Every cell > 1.55 V or 2 h 30 min which ever comes first	1.7 A for 4 h	1.55 V per cell
1 C ₁ A (17 A)	1 h	Every cell > 1.57 V or 1 h 15 min which ever comes first	1.7 A for 4 h	1.55 V per cell

Table 2 - Charge rates

(*) Low charge rate 0.1 C₁A ([1.7 A](#)) is recommended after cell shorting.

Example: main charge (step 1) at [17 A](#) for 1 h:

- If the voltage of each cell is lower than 1.57 V, continue the charge for 15 minutes maximum (0.25 h) and stop if the voltage reaches 1.57 V before 15 minutes. Then continue with the final charge (step 2)
- If the voltage of each cell is higher than 1.57 V, continue with the final charge (step 2)

5-2. Other methods of charging

NOTE: Do not use this procedure for charging the battery during normal maintenance

Other methods that fully charge the battery can be used, for example pulse charging. However, in any case, individual cell voltage checks (Voltage ≥ [1.55 V per cell](#)) and electrolyte adjustments must be carried out using a final overcharge sequence at constant current [1.7 A](#) for 4 hours. If specific instructions are not given in the charger operating manual, you must first contact Saft.

5-3. Active standby mode (use of a trickle charge)

WARNING: THIS MAY CREATE CONDITIONS FOR A THERMAL RUNAWAY WITH ALL ITS CONSEQUENCES (UN-SCHEDULED REMOVAL WITH THE POSSIBILITY OF THE TOTAL LOSS OF THE BATTERY AND A DELAYED OR CANCELED FLIGHT).

CAUTION: WATER CONSUMPTION.

NOTE: Do not use this procedure for charging the battery during normal maintenance

The battery is continuously charged to an overcharge condition. Saft does not recommend this method, however some operators take responsibility for its use.

This method is not reliable due to quantity and inaccuracy of water consumption.

Example: if a 40 Ah battery remains on a continuous trickle charge of 3 mA/Ah for one month, the total consumption of water is 35 cm³ (2.1 in³)/cell.

The operator must adjust the electrolyte level before placing the battery on board the aircraft. Otherwise the risk of a battery incident exists (cells dry out before the normal end of the interval maintenance).



**Component Maintenance Manual
170CH-1**

PAGE INTENTIONALLY LEFT BLANK

TESTING AND FAULT ISOLATION

1. Introduction

This chapter is a maintenance guide for the technician.

It shows, for the main causes of failure, either removed for unscheduled maintenance or during scheduled maintenance, the procedures to apply by referring to the corresponding chapter of the CMM. In no case can this diagnosis help replace the technician's expertise or a training on the functioning of the batteries.

2. Battery faults

2-1. Battery electrical faults

Problem	Probable cause	Correction
(1) Zero battery open-circuit voltage	(a) Defective electrical connector (no contact made) (b) Link broken	- Check electrical contacts, links and tightness of nuts (refer to Inspection/check)
(2) Zero volt with the battery set to "discharge"	(a) Battery fully discharged (b) Battery circuit open or contacts defective (c) Cell completely dry	- Do an insulation check (refer to Inspection/check) - Examine the contacts and links - Make sure the terminal nuts are tight (refer to Inspection/check) - Refer to related subsequent steps - Replace the cell
(3) Low insulation	(a) Leakage of electrolyte	- Disassemble and clean the battery (refer to Disassembly and Cleaning) - Do an electrolyte level check (refer to Inspection/check)

Table 1001 - Battery electrical faults

2-2. Cell faults

Problem	Probable cause	Correction
(1) Too much water decrease for all battery cells	(a) Charge much more than the limit or too much charge at high temperature (b) Previous maintenance has not been done	- Examine the cause of excessive charge - If necessary, adjust to normal operating temperature (refer to Description and operation)
(2) High water dispersion: water consumption in one or more cell(s) is very different from the other cells in the battery	(a) more than 30 % above the average value of added water in all cells: leaking cell(s) (b) less than 30 % below the average value of added water in all cells: cell(s) with damaged separator(s)	- Disassemble the battery (refer to Disassembly). Clean the battery (refer to Cleaning). Replace the cell(s). Charge and do an electrolyte level check (refer to Inspection/check) - Do the Supplementary test (refer to Inspection/check). If necessary, replace the cell(s) - Note the cell location and check the level of water consumption versus other cells at the next maintenance
(3) A cell has a higher voltage at the start of charge than is defined in paragraph. Charge chapter Description and operation	(a) Dry cell	- When the defect occurs, add 5 cm ³ (0.3 in ³) of distilled water M01 to the cell. Do not adjust more accurately until the end of the charge
NOTE: If you charge a cell with an insufficient quantity of electrolyte, the temperature may increase too much		
(4) A cell has a lower voltage at the end of charge than is defined in paragraph. Charge chapter Description and operation	(a) The cell was operated at temperatures and charge rates outside the limits, and the separator is damaged (b) Usual wear after long operation	- Replace the cell (refer to Disassembly, Assembly AND Storage (including transportation))
(5) Low capacity cell	(a) insufficient balancing (b) Usual wear after long operation (c) Unusual operation, operation at high temperature or operation with low electrolyte	- Repeat Charge and discharge at 17 A up to three times - Replace the cell (refer to Disassembly, Assembly AND Storage (including transportation)) - Do the applicable procedure (refer to Inspection/check)
(6) Cell with a swollen case	(a) Cell operated with low electrolyte level; deterioration of separators and damaged plates	- Replace the cell (refer to Disassembly)
(7) Cell with zero voltage when the battery circuit is open	(a) Short-circuited cell	- Replace the cell (refer to Disassembly)

Table 1002 - Cell faults

2-3. Physical faults

Problem	Probable cause	Correction
(1) Leakage of electrolyte	<p>(a) Incorrect adjustment of electrolyte level</p> <p>(b) Cell polarity incorrect during high-rate discharge (for example, during the engine start)</p> <p>(c) Too much charge at high temperature or too much current</p> <p>(d) The lower nut is not correctly tightened</p>	<p>- Disassemble and clean the battery (refer to Disassembly and Cleaning chapters). Do an electrolyte level check (refer to Inspection/check)</p> <p>- Disassemble and clean the battery (refer to Disassembly and Cleaning) Do an electrolyte level check (refer to Inspection/check)</p> <p>- Investigate the cause of excessive charge. If necessary, adjust to normal operating temperature (refer to Description and operation)</p> <p>Disassemble and clean the battery (refer to Disassembly and Cleaning)</p> <p>- Do an electrolyte level check (refer to Inspection/check)</p> <p>Torque the lower nut (refer to Assembly chapter)</p>
(2) Electrolyte found in the battery box	<p>(a) Damaged cell case</p> <p>(b) Leakage of electrolyte</p>	<p>- Replace the cell if necessary and refer to related subsequent steps</p> <p>- Disassemble and clean the battery (refer to Inspection/check and Cleaning)</p> <p>- Do an electrolyte level check (refer to Inspection/check)</p>
(3) Corrosion on the links	<p>(a) Operation in acidic air</p> <p>(b) Mechanical damage to nickel plating</p>	<p>- Make sure the battery test bench and the storage areas have no materials which can give off acid fumes</p> <p>- Replace the damaged links (refer to Disassembly, Assembly AND Storage (including transportation))</p>
(4) The links are too hot	(a) Loose terminals nuts	- Make sure the nuts are torqued (refer to Inspection/check)
(5) Battery box & cover damages: - Scratches - Dents, deformations which affect fit or impede the electrical performances of the battery or any of its components - Visible cracks to box or cover - Box mounting bracket damage	<p>(a) Various, transport</p> <p>(b) Mechanical stress, drop, transport</p> <p>(c) Mechanical stress, drop, transport</p> <p>(d) Mechanical stress, drop, transport</p>	<p>- Clean, make sure labels are readable, if not readable replace label(s)</p> <p>- Replace battery box, cover, and affected component(s) (refer to Disassembly, Assembly)</p> <p>- Replace battery box and / or cover</p> <p>- Replace brackets (refer to Disassembly, Thorough cleaning, Assembly)</p>

Table 1003 - Physical faults



**Component Maintenance Manual
170CH-1**

PAGE INTENTIONALLY LEFT BLANK

DISASSEMBLY

1. Introduction

1-1. General

CAUTION: BATTERY DISASSEMBLY SHOULD ONLY BE PERFORMED ON A FULLY DISCHARGED BATTERY. REFER TO CHAPTER [Residual discharge](#) and [Cell shorting](#).

NOTE: Refer to [Testing and fault isolation](#) to identify possible causes of problems. This chapter gives the necessary level of disassembly to identify and correct possible issues.

The instructions found in this chapter are designed to allow the maintenance personnel to completely disassemble the battery for the purpose of [General overhaul](#). However, some maintenance operations do not require complete disassembly. The item numbers are those of the [Illustrated parts list](#).

1-2. Safety

Refer to chapter [Safety](#) for caution, risks, and proper personal protective equipments (PPE).

1-3. Job set-up information

1-3-1. Standard tools

Refer to chapter [Standard tools](#) in [Special tools, fixtures, equipment and consumables](#).

1-3-2. Special tools

When special tools are used in this chapter, they are identified by a code number listed in [Special tools, fixtures, equipment and consumables](#) chapter.

2. Disassembly of the battery

NOTE: All item numbers from the Illustrated Part List (IPL, Fig. 1) are referred by "(###)". Item numbers are linked by hyper-text to the IPL. Decimal of item numbers referred by "(###.#)" are for illustration aid only and are not listed in the IPL

2-1. Removal of the cover complete

CAUTION: AVOID CONTACT BETWEEN THE COVER AND THE CELL TERMINALS OR LINKS.

- Undo the retaining latches
- Remove the battery cover complete ([020](#))

2-2. Removal of the cells

CAUTION: DO NOT PINCH CABLE HARNESS AGAINST SHARP EDGES.

CAUTION: DO NOT BEND HEATER TABS EXCESSIVELY.

NOTE: Make note of the proper placement of the links ([090](#) to [110](#)) and each cells in relation to one another before removal (per log book or equivalent).

NOTE: To facilitate ease of removal, remove the center cell in each row first.

- Remove cable ties ([115](#)).
- Remove the nuts ([130](#)) and washers ([140](#) to [170](#)).
- Remove the stirrup ([350](#)).
- Remove the thermistor (340.4), thermostats (340.1, 340.2, and 340.3), and mid point sensor (340.5).
- Remove all links ([090](#) to [110](#)).
- Remove nuts ([070](#)) and washers ([080](#)).
- To remove the cell assemblies ([120](#)), fully screw the cell extractor tool [T04](#) onto a cell terminal then pull up.
- Remove the heaters H1 to H3 (340.61 to 340.63).

2-3. Removal of the liner-spacer kit

- Remove each liner-spacer ([190](#)) taking note the location, position, and count (per figure: [7004 - Liner-spacer kit](#)).
- Remove the partition edge protector ([360](#)).

2-4. Removal of the power connector complete

- Remove the power connector cover (295) -if present-
- Remove the screws (200) with the washers (210).
- Remove the power connector assembly (280) and the O-ring (290).
- Remove the nuts (230).
- Remove the lock washers (240), links (250 and 260), and the washers (270).

2-5. Removal of the sensor connector complete

CAUTION: DO NOT BEND HEATER TABS (340.61 TO 340.63) EXCESSIVELY.

- Remove the sensor connector cover (346) -if present-
- Remove the nut (344).
- Remove the sensor connector assembly (340) and O-ring (342).

2-6. Removal of the box mounting brackets

NOTE: Removal of the box mounting brackets is only necessary if damaged

- Remove the screws (019).
- Remove the box mounting brackets (017).

CLEANING

1. Introduction

The instructions in this chapter are for the general cleaning of your Saft aircraft battery. The instructions under "[Light cleaning](#)" are to be done each time the battery is removed from the aircraft, and can be accomplished with no disassembly of the battery. The section "[Thorough cleaning](#)" includes the instructions for the cleaning of a disassembled battery for the purpose of a [General overhaul](#).

2. Safety

Refer to chapter [Safety](#) for caution, risks, and proper personal protective equipments (PPE).

3. Equipment

3-1. Standard tools

Refer to chapter [Standard tools](#) in [Special tools, fixtures, equipment and consumables](#).

3-2. Special tools

When special tools are used in this chapter, they are identified by a code number listed in [Special tools, fixtures, equipment and consumables](#) chapter.

3-3. Consumables

When consumables are used in this chapter, they are identified by a code number listed in [Special tools, fixtures, equipment and consumables](#) chapter.

4. Light cleaning

On an assembled battery.

CAUTION: DO NOT USE SOLVENT, PETROLEUM SPIRITS (SOLVENTS) OR OTHER PRODUCT CONTAINING CHLORIDE FOR CLEANING THE BATTERY. THE USE OF SOLVENTS CAN DEGRADE METAL AND PLASTIC PARTS.

NOTE: All item numbers from the Illustrated Part List (IPL, Fig. 1) are referred by "(###)". Item numbers are linked by hyper-text to the IPL. Decimal of item numbers referred by "(###.#)" are for illustration aid only and are not listed in the IPL

4-1. Procedure

WARNING: TO PREVENT INJURY WHEN USING COMPRESSED AIR, POINT AIRFLOW AWAY FROM THE BODY. USE SAFETY GOGGLES TO PREVENT EYE INJURY FROM AIRBORNE PARTICLES.

- Remove the battery cover complete (020)
- Check the battery vent tubes to make sure that they are clean and clear
- Hand tight the vent-valve assemblies (180) with the universal vent-valve wrench T01
- Remove potassium carbonates (white deposits) from the top of all cell assemblies (120) using a stiff bristle, non-metallic brush
- Disperse residual salts and dust particles from the battery using blasts of clean, dry compressed air
- Coat all nuts (130), washers (140 to 170), and links (090 to 110) with M02 (use a nonmetallic paintbrush)

5. Thorough cleaning

5-1. Procedure

Fully disassemble the battery (refer to [Disassembly](#) chapter)

5-1-1. Cell assemblies

CAUTION: DO NOT SOAK THE CELLS IN WATER.

Make sure the vent-valve assembly (180) is finger tight using the universal vent-valve wrench T01.

Clean the cell assembly (120) with warm water and a soft brush to easily remove all the electrolyte and mineral salts from the terminals, the cover and the sides of the cell cases.

Wipe the cell with a cloth and let dry

5-1-2. Box and cover

Clean the box and cover complete (010) with soapy water M03, wipe with a cloth and let dry.

5-1-3. Nuts, washers, links, and stirrup

Clean nuts (070, 130, 135, 230, 310, and 320), washers (080, 140 to 170, and 240), links (090 to 110, 250 and 260), and stirrup (350) in soapy water M03 with a brush, rinse well with clean water and let dry.

5-1-4. Liner-spacer kit

Clean the liner-spacer kit (190) in warm water and let dry.

5-1-5. Power connector

CAUTION: DO NOT SUBMERGE THE POWER CONNECTOR

Wipe the power connector assembly (280) clean using damp cloth and let dry.

5-1-6. Sensor connector harness

CAUTION: DO NOT SUBMERGE THE SENSOR CONNECTOR

CAUTION: CARE MUST BE TAKEN NOT TO PULL ON WIRES OR TWIST OR BEND THE HEATER TABS (340.6) BACK AND FORTH.

Wipe the sensor-connector wire harness and heater clean using damp cloth and let dry.

5-1-7. Vent-valve

CAUTION: THE CLEANING OF THE VENT-VALVE MUST BE DONE WHEN THE CELLS ARE INSTALLED IN THE BOX ASSEMBLY.

CAUTION: VENT-VALVES SHALL REMAIN INSTALLED ON THE CELLS WHEN EVER THE CELLS ARE NOT INSTALLED IN THE BATTERY BOX.

5-1-7-1. Removal of the vent-valve

Remove the vent-valve assembly (180) using the universal vent-valve wrench T01

Cover cell vent-valve hole using a lint free cloth to prevent unwanted debris from entering the cell

Soak vent-valve assemblies in distilled water M01 for 30 min to 4 h to remove electrolyte salts from vent holes

5-1-7-2. Installation of the vent-valve

Make sure the vent-valve assemblies (180) are in good condition. Replace the vent-valve assemblies (180) if they are worn.

Install the vent-valve assembly (180) finger tight with the universal vent-valve wrench T01.

5-1-7-3. Box mounting bracket screws

NOTE: Cleaning of the box mounting bracket screws (019) is only required during the replacement of the box mounting brackets (017).

Apply mild solvent (M05) and stiff bristle brush (non-metallic) to remove old thread-locking adhesive (M04) residue.

5-2. Lubrication

When the battery is clean (and after installation of the vent-valve assembly), coat all upper nuts (070 and 130), washers (160), and links (090 to 110) with M02 (use a nonmetallic paintbrush).

INSPECTION/CHECK

1. Introduction

This chapter includes the checks, maintenance procedures, and functional tests that must be done to use Saft batteries in flight and on the ground.

NOTE: All item numbers from the Illustrated Part List (IPL, Fig. 1) are referred by "(###)". Item numbers are linked by hyper-text to the IPL. Decimal of item numbers referred by "(###.#)" are for illustration aid only and are not listed in the IPL.

2. Maintenance intervals

The aircraft manufacturer and / or operator is responsible for defining the usage and function, including maintenance intervals, for aircraft batteries installed in its aircraft. Saft only provides recommendations that requires the agreement of the aircraft manufacturer and / or operator.

NOTE: Maintenance steps should be completed in a battery shop.

Saft distinguishes between three types of maintenances: periodical check, regular check, and general overhaul.

2-1. Periodical check

The periodical check essentially consists of voltage and insulation checks, discharge of residual capacity, and charge with electrolyte level adjustment. The main purpose of this periodical check is to add water, which is consumed by electrolysis during battery overcharge. It is normally applied between regular checks but can be omitted if the water consumption measured at the regular check is within allowable limits.

2-2. Regular check

The regular check is the same as the periodical check except that the battery is also deep-discharged ('balancing'), followed by a capacity check cycle.

2-3. General overhaul

The general overhaul is the same as the regular check except that the battery is also disassembled and thoroughly cleaned and inspected.

3. Recording

It is very important to record the battery check values (capacity, end of charge voltage, water consumption) for each cell as required in the battery logbook for each maintenance. It is recommended that an operator tracks these maintenance data in order to verify the interval is correct relative to that particular operation. This may also allow the interval to be extended if the data justifies it.

4. Safety

Refer to chapter [Safety](#) for caution, risks, and proper personal protective equipments (PPE).

5. Equipment

5-1. Standard tools

Refer to chapter [Standard tools](#) in [Special tools, fixtures, equipment and consumables](#).

5-2. Special tools

When special tools are used in this chapter, they are identified by a code number listed in [Special tools, fixtures, equipment and consumables](#) chapter.

6. Periodical check

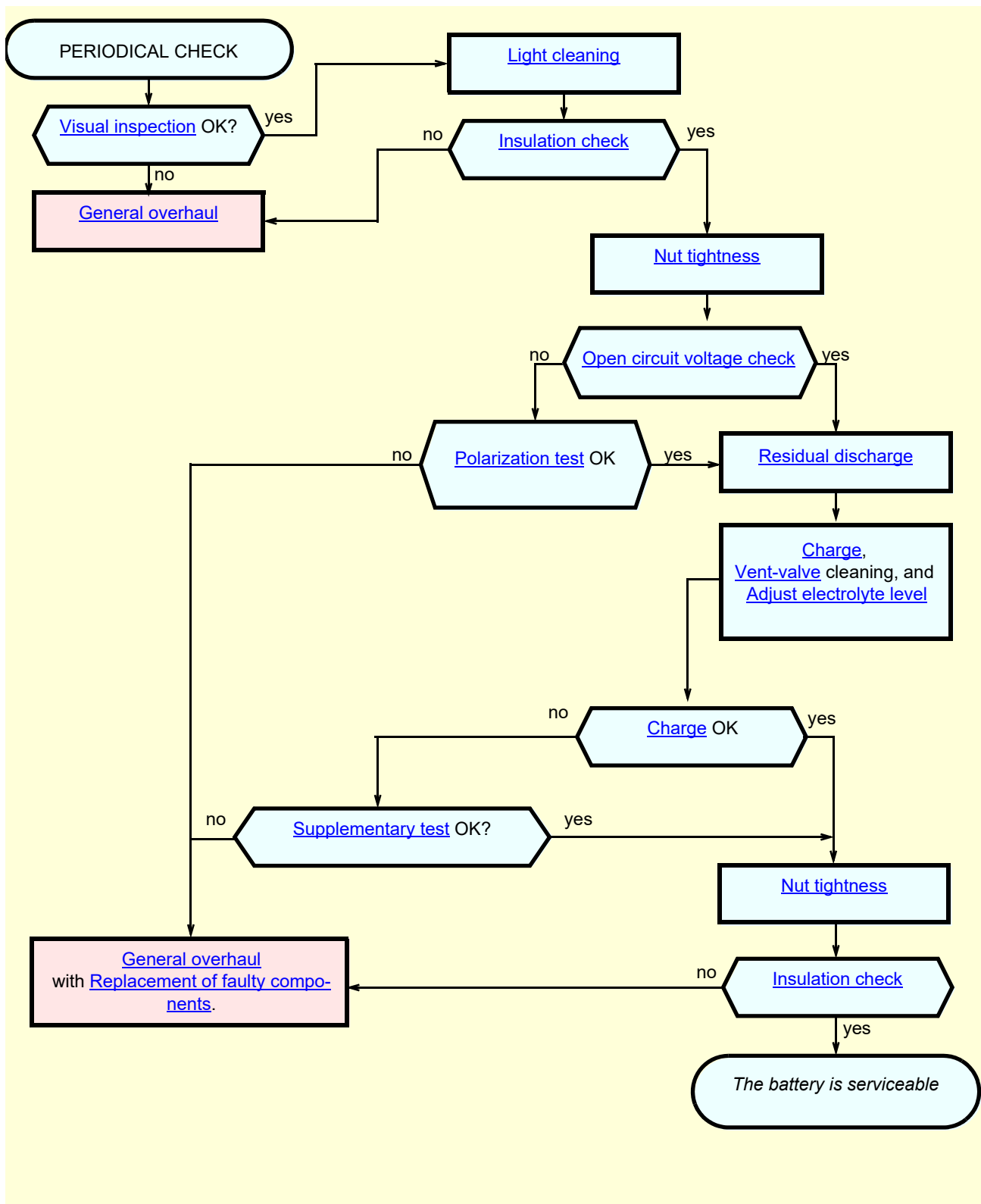

Figure 5001 - Periodical check

NOTE: Time periods are given as a guideline. Modify in accordance with operational experience.

NOTE: Periodic and regular maintenance checks may be combined if operating hours permit.

At specific intervals according to aircraft use or every 3 months, test the battery according to the above figure. Consult the aircraft manufacturer and/or operator for specific maintenance intervals or special procedures to be followed.

6-1. Visual inspection

CAUTION: WORN AIRCRAFT POWER CONNECTORS AND/OR LOOSE CONNECTIONS CAN GREATLY AFFECT THE PERFORMANCE OF THE BATTERY. A DEFECTIVE POWER CONNECTOR CAN CAUSE OVERHEATING, BATTERY SELF-DISCHARGE AS WELL AS LOW VOLTAGE IN SERVICE.

Visual inspection should be done each time the battery is removed for maintenance from the equipment.

- Remove the cover complete (020)
- Visually check each cell assembly (120) for evidence of electrolyte leakage. If OK proceed to [Light cleaning](#). If salt or traces of electrolyte is detected identify as NOT OK, proceed to [General overhaul](#). Excessive salt around terminal posts indicate possible leakage from the terminal O-ring. During [General overhaul](#), verify torque of the lower nut (135) (refer to chapter [Assembly](#)).
- Inspect the links (090 to 110), upper nuts (130), and washers (160). The hardware should be free of bends, tarnish, corrosion, burns, or any loss of nickel plating. Minor tarnish can be polished off with a fine wire brush. If OK proceed to [Light cleaning](#). If NOT OK proceed to [General overhaul](#) and replace defective hardware.
- Check the power connector complete (220) for evidence of arcing, corrosion, cracks, or cross-threaded terminals. If OK proceed to [Light cleaning](#). If NOT OK proceed to [General overhaul](#) and replace the defective power connector complete.
- Inspect the sensor connector complete (300) for bent or loose pins, corrosion, cracks, faulty wire connections, evidence of arcing, or cracked or loose potting material. If OK proceed to [Light cleaning](#). If NOT OK proceed to [General overhaul](#) and replace the defective sensor connector complete.
- Inspect the temperature sensor and blanket harness assembly for obvious damage. This in no way replaces the full testing procedures found hereafter which ensures full operation of the sensor assembly. If OK proceed to [Light cleaning](#). If NOT OK proceed to [General overhaul](#) and replace the defective sensor connector complete (300).
- Inspect the thermostat assemblies (as applicable) for any damaged or loose wire connections, cracks, dents, or other physical damage. If OK proceed to [Light cleaning](#). If NOT OK proceed to [General overhaul](#) and replace the defective sensor connector complete (300).
- Visually check all wiring insulation to ensure there is no evidence of cracks, cuts, or bubbling. If OK proceed to [Light cleaning](#). If NOT OK proceed to [General overhaul](#) and replace the defective sensor connector complete. Any evidence of damage to the temperature sensor and/or heater blanket harness assembly requires the sensor connector complete (300) replacement.
- Inspect the battery box assembly (015) and cover complete (020) for any damage. Make sure the box mounting brackets (017) are free of any deformations or abrasions. If NOT OK, replace the damaged box mounting brackets (017). Make sure the cover gasket (040) is undamaged and fully secured to the cover complete (020). If OK proceed to [Light cleaning](#). If NOT OK proceed to [General overhaul](#) and replace the damaged box assembly (015) or cover complete (020).

6-2. Insulation check

NOTE: A breakdown in electrical insulation between the cell assemblies (120) and the battery box assembly (015) will result in a "leakage" current, which over time will discharge the battery.

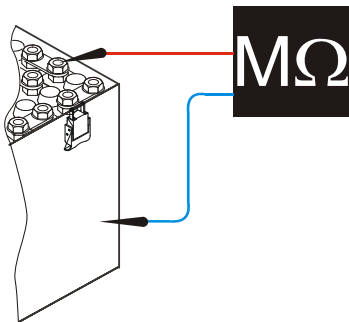

- Set the Meg-ohmmeter to 250 V DC
- Measure the insulation between the positive terminal of each cell assembly (120) and the battery box assembly (015)
- Measure the insulation between the power connector (280) positive pin and the battery box assembly (015)
- Measure the insulation between each pin of the sensor connector complete (300) and the battery box assembly (015)

Refer to the table below for the acceptance criteria.

250 KΩ	2 MΩ	10 MΩ	
Do a General overhaul Check cause(s) per Testing and fault isolation	Acceptable but Thorough cleaning is recommended	Acceptable for in service battery. For a new battery (direct from factory with no charge made by the customer) a Thorough cleaning is recommended	Mandatory level of insulation for new or in service battery after Thorough cleaning

Table 5001 - Acceptance criteria for insulation check

6-3. Nut tightness

Tighten and check the torque of all cell-terminals upper nuts (130) (refer to [Fits and clearances](#)).

6-4. Open circuit voltage check

Measure the open circuit voltage of each cell assembly (120). If all the cells are > 1.05 volt, continue with [Residual discharge](#). Otherwise, do a [Polarization test](#).

6-5. Polarization test

Charge the battery at [1.7 A](#) for 1 hour 30 min.

Leave the battery on open circuit for 1 hour.

Measure the open circuit voltage of each cell assembly (120). If any cell is zero volt or has a negative polarity, do a [General overhaul](#) with [Replacement of faulty components](#). If all cells are above zero volt, continue with [Residual discharge](#).

6-6. Residual discharge

Discharge the battery at the [17 A](#) or [8.5 A](#) rate until each cell in the battery is discharged to 1.0 volt or below.

6-7. Adjust electrolyte level

WARNING: TAKE CARE NOT TO TILT CELLS WHILE VENT-VALVES ARE LOOSENED OR REMOVED. CONTACT OF ELECTROLYTE WITH SKIN CAN CAUSE BURNS (REFER TO CHAP. [Safety](#)). IF CONTACT OCCURS, FLUSH AREA WITH LARGE AMOUNTS OF WATER FOR 15 TO 30 MINUTES. ELECTROLYTE IN THE EYES IS VERY SERIOUS. FLUSH WITH WATER AND CONTACT A DOCTOR IMMEDIATELY.

CAUTION: USING ANYTHING OTHER THAN DISTILLED OR DEIONIZED WATER [M01](#) IN NICKEL-CADMIUM CELLS WILL CAUSE ELECTROLYTE CONTAMINATION AND IRREVERSIBLE DAMAGE TO THE CELLS.

CAUTION: THE BATTERY MUST BE FULLY CHARGED BEFORE ADJUSTING THE ELECTROLYTE LEVEL. USE ONLY DISTILLED OR DEIONIZED WATER [M01](#) (REFER TO CHAPTER [Special tools, fixtures, equipment and consumables](#)).

DO NOT RE-USE WATER REMOVED FROM CELLS.

THE VOLUME REQUIRED TO LEVEL THE FIRST CELL WILL SERVE AS A GUIDE FOR REQUIREMENTS OF THE REMAINING CELLS BUT THE AMOUNT OF WATER REQUIRED FOR EACH CELL CAN VARY, SO CARRY OUT THIS CHECK ON A CELL BY CELL BASIS. EACH CELL MUST BE LEVELED INDIVIDUALLY. IF THE QUANTITY OF WATER ADDED PER CELL IS ABOVE 80 % OF THE ELECTROLYTE WATER VOLUME SHOWN IN THE SPECIFICATION TABLES (REFER TO CHAPTER [Technical data](#)), CHECK THE CHARGING SYSTEM. IF IT IS FUNCTIONING PROPERLY, SHORTEN THE TIME PERIOD BETWEEN SERVICING.

CAUTION: THE MAXIMUM AMOUNT OF ADDED WATER IS 15 cm^3 (0.92 in^3) per cell.

Always take appropriate precautions to prevent any foreign substances from entering the cell. Anything other than distilled or deionized water [M01](#) that enters the cells will cause electrolyte contamination and will affect overall performance.

The amount of time that the vent-valve assemblies (180) are removed from the cell assembly (120) for maintenance should be limited to prevent as much air as possible from entering the cell. Carbon dioxide in the air will combine with the electrolyte to form potassium carbonate. Potassium carbonate will increase the internal resistance of the cells and thus decrease the performance at low temperatures and during high rate discharges. Always make sure that the vent-valve assemblies (180) are properly secured while the battery is in use.

Electrolyte level adjustment **must be done during the last 15-30 minutes** of the 4 hours overcharge at [1.7 A](#) rate of charge or last 15-30 minutes of the 5 hours at 0.1C₁ A for the supplementary test.

Adjust the level of electrolyte, one cell at a time, using the following instructions:

- 1. Remove the vent-valve assemblies (180) with its O-ring using the vent-valve assembly wrench T01
- 2. Check the nozzle length before fitting it to the syringe (refer to paragraph Special tools for proper nozzle)
- 3. Insert the syringe T02 into the cell assembly (120) opening until the shoulder of the nozzle rests on the vent-valve seat.

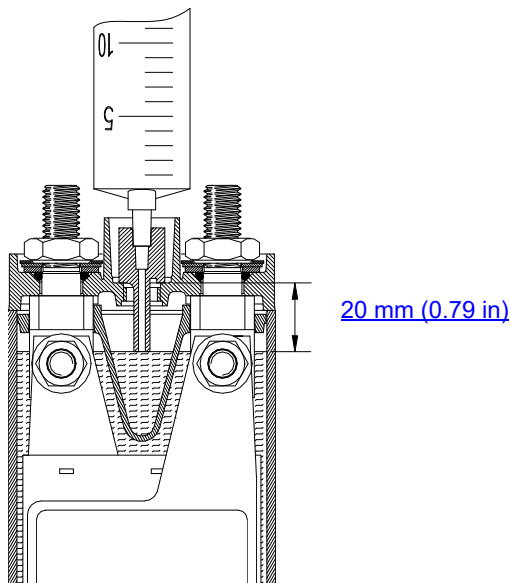

Figure 5002 - Position of syringe in cell vent seat

- 4. Withdraw the plunger and check for any liquid in the syringe. Any excess liquid in the cell will be drawn into the syringe until the electrolyte is level with the end of the nozzle. This is the correct level for the electrolyte. If the liquid level is too low, the syringe will remain empty, indicating that the end of the syringe nozzle did not reach the liquid in the cell. In this case, replenish low electrolyte using distilled water M01.
- 5. Draw 5 cm³ (0.3 in³) of the distilled water M01 into the syringe and inject it into the cell and,
- 6. With the syringe nozzle remaining on the vent-valve assembly (180) seat, slowly withdraw the plunger in the syringe one time again
- 7. If the syringe remains empty, repeat steps 5 and 6, counting the number of 5 cm³ (0.3 in³) injections required to achieve the correct level. Record the amount of water added to each cell on the maintenance record
- 8. At the point in step 6 when some excess liquid is drawn into the syringe, the correct level for that cell has been reached. Expel the excess liquid into a separate container for disposal. **Do not re-use the liquid removed from cells.** Check with local authorities for proper disposal of hazardous waste

6-8. Supplementary test

This test is used to confirm cell(s) fault(s):

- Continue to charge for an additional 5 h at 0.1C₁ A (1.7 A)
 - The individual cell voltage (CVH175KH) must be ≥ 1.55 V per cell
 - Adjust electrolyte level
- If the voltage criteria is still not met within the 5 h, replace the defective cell assembly(s) (120). Follow General overhaul
- If cell assembly(s) (120) voltage(s) decreases by ≥ 0.03 V between the beginning and the end of the supplementary test, then replace the defective cell assembly(s) (120). Follow General overhaul.

NOTE: Cell voltage should be checked every 30 min. If the voltage criteria is reached before 5 h, you can stop the supplementary test.

7. Regular check

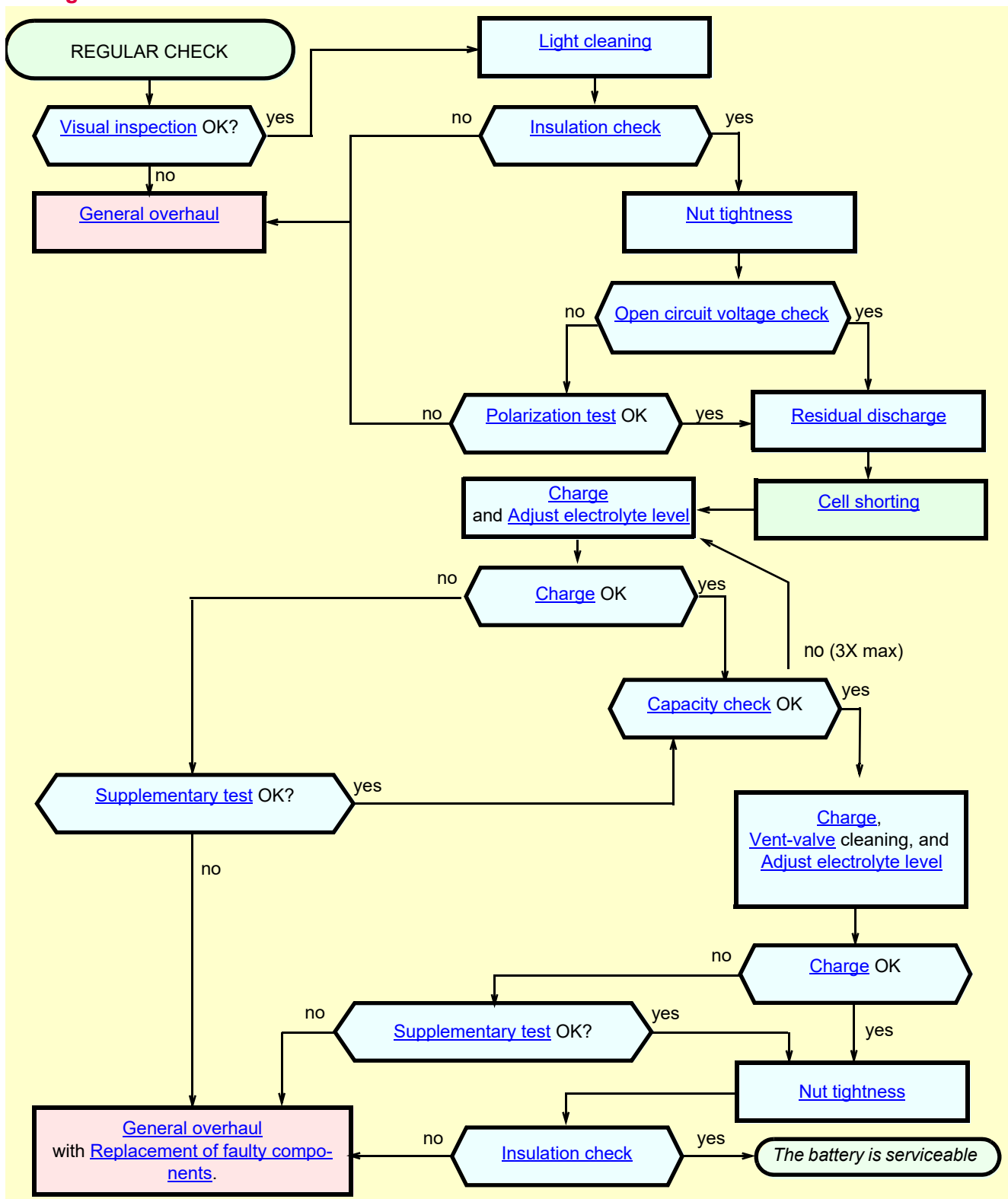

Figure 5003 - Regular check

NOTE: Time periods are given as a guideline. Modify in accordance with operational experience.

NOTE: Periodic and regular maintenance checks may be combined if operating hours permit.

At specific intervals according to aircraft use, or after a maximum of one year, test the battery according to the above figure. Consult the aircraft manufacturer and/or operator for specific maintenance intervals or special procedures to be followed.

7-1. Cell shorting

As each cell's voltage drops below 1.0 V, connect an equalizing resistor [T03](#) across each cell terminals. Leave the resistors in position for 12 to 24 hours to allow each cell to completely discharge and the battery to cool.

NOTE: As an alternative to the resistor, a shorting clip can be applied when the voltage has dropped to 0.5 V per cell.

NOTE: It is recommended to use low charge rate 0.1 C₁A ([1.7 A](#)) rate after cell shorting.

7-2. Capacity check

This procedure is used to calculate the battery capacity. It can be done in 2 different methods.

NOTE: If the capacity check is not OK, do: [Charge](#), [Adjust electrolyte level](#), and [Capacity check](#) loop 3 times maximum. If capacity check is still not OK then follow [General overhaul](#).

7-2-1. Method 1

This method is suitable for devices that can record individual cell voltages and discharge current continuously over time.

- Discharge the battery at [17 A](#) and record the individual voltages of all cells
- Record the time when each cell falls to 1.0 V. Once the cell voltage falls between 0.5 V and 1.0 V, apply equalizing resistor [T03](#) across the low-voltage-cell terminals
- All cell voltages must be ≥ 1.0 V at [1 hour](#)

7-2-2. Method 2

This method is especially suitable for battery shop that manually records the voltage using a multimeter.

- Discharge the battery at [17 A](#) for [1 hour](#)
- Record the voltage of each cell at the end of [1 hour](#):
 - If the voltage of each cell is ≥ 1.0 V, then the capacity test is OK
 - If any cell voltage is < 1.0 V, the capacity test is NOT OK

8. General overhaul

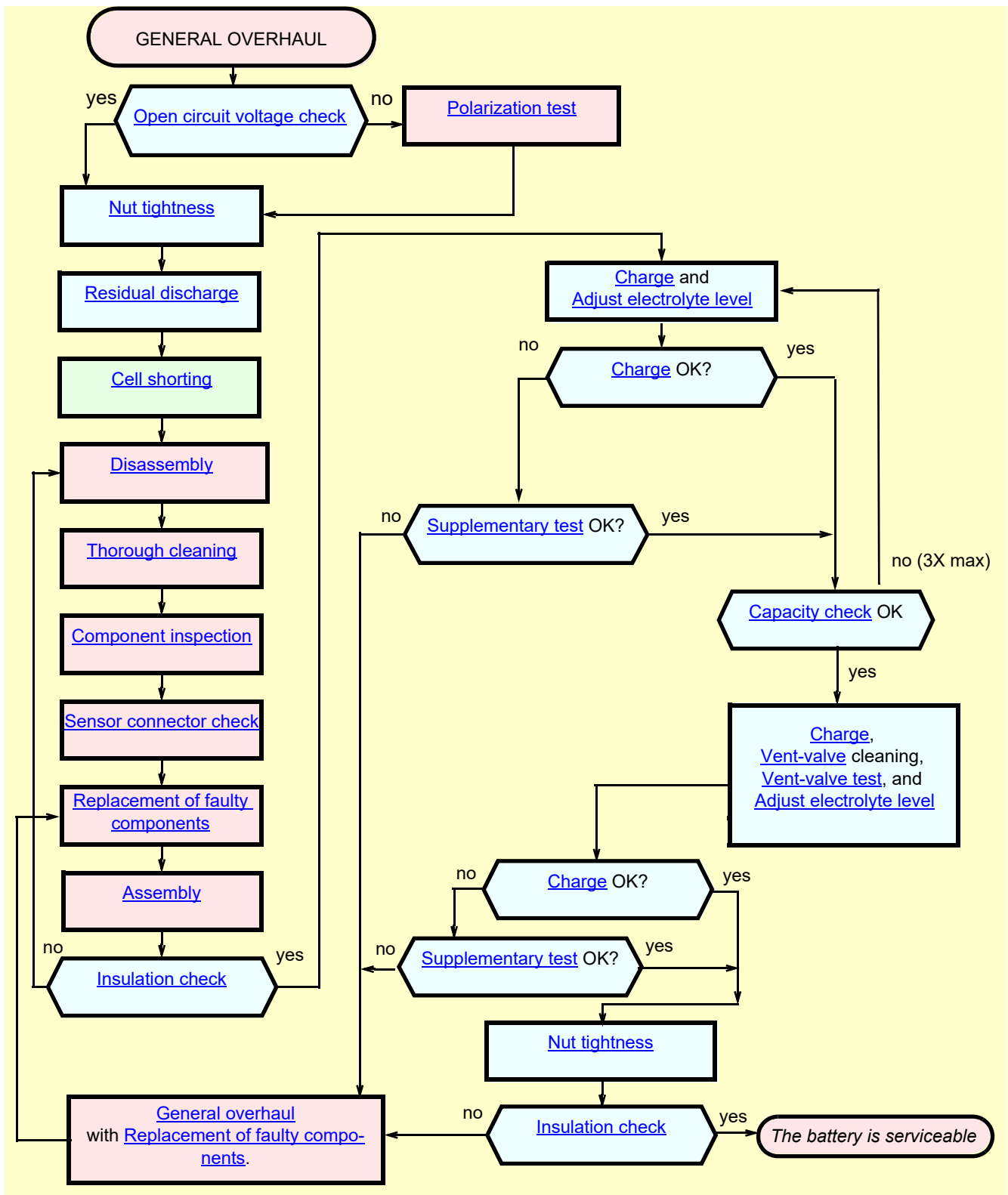

Figure 5004 - General overhaul

NOTE: Time periods are given as a guideline. Modify in accordance with operational experience.

At specific intervals according to aircraft use, or after a maximum of one year, test the battery according to the above figure. Consult the aircraft manufacturer and/or operator for specific maintenance intervals or special procedures to be followed.

8-1. Component inspection

8-1-1. Cells

Make sure that the lower terminal nuts (135) are tight (refer to [Fits and clearances](#) chapter).

Verify that cell-containers show no leakage.

8-1-2. Box

Make sure the box assembly (015) sides are straight.

8-1-3. Nuts, links, washers, and stirrups

Discard nuts (070, 130, and 135), links (090 to 110), washers (080, 140 to 170), and stirrups (350) that show signs of corrosion or damage.

8-1-4. Power connector

Check the power connector complete (220) for evidence of arcing, corrosion, cracks, or cross-threaded terminals. Replace the defective power connector complete.

8-2. Replacement of faulty components

8-2-1. Cells - 3/5 cells rule

Saft strongly recommends to change all the cells or replace the complete battery if:

- **One or more cells are found to be faulty and 5 of the original cells in the battery have been previously changed during the previous maintenance,**

or

- **Three (3) or more cells are found to be faulty during the same maintenance.**

The 3/5 cells rule does not apply to the following failures:

- Mechanical failure such as terminal thread damage
- Cell leakage
- Cell short-circuit

NOTE: All cells to be replaced must be replaced by new Saft cells.

8-2-2. Other components

Any other components that are to be replaced must be replaced by new Saft components.

8-3. Sensor connector check

8-3-1. Insulation check

Make sure that the insulation between each pin of the sensor connector complete (300) and all metal parts of the sensor connector is $\geq 10 \text{ M}\Omega @ 250 \text{ VDC}$

Component Maintenance Manual 170CH-1

8-3-2. Sensor connector assembly check

Do this test in a climatic chamber or equivalent device with the sensor connector complete (300) disassembled from the battery. Check the sensor connector per table below:

Check of	Between	Value
Middle point, M	A-eyelet	4.95 kΩ to 5.05 kΩ
Thermostat, T1	C-D	opens on rise @ +8 °C ± 5 °C (+46 °F ± 9 °F)
Thermostat, T2	D-J	opens on rise @ +8 °C ± 5 °C (+46 °F ± 9 °F)
Heater	E-J	29.7 Ω to 36.3 Ω @ +23 °C ± 7 °C (+72 °F ± 13 °F)
Thermostat, T3 (Red)	G-H	21.6 kΩ to 22.4 kΩ @ +23 °C ± 7 °C (+72 °F ± 13 °F) closes on rise @ +71 °C ± 5 °C (+160 °F ± 9 °F)
Thermistor, S	F-K	35.3 kΩ to 38.1 kΩ @ +20 °C ± 1 °C (+68 °F ± 1.8 °F)
Insulation	Each pin of the connector and all metal parts of the sensor	≥ 10 MΩ @ 250 VDC @ +23 °C ± 7 °C (+72 °F ± 13 °F)

Table 5002 - Sensor connector check

8-4. Vent-valve test

NOTE: The vent-valve test is not necessary if the full set of used vent-valves is replaced by a brand new one each year during the [General overhaul](#).

NOTE: Vent-valves should be cleaned before testing (refer to [Vent-valve](#) cleaning).

NOTE: If the vent-valve does not open during the test increase the pressure slowly until the vent-valve opens (one time, to 1.4 bar (20 psi) max) to ensure functionality, then repeat the full test.

This test should be done while the battery is on charge.

Check the operation of the vent-valve assembly as follows:

- Install the vent-valve assembly (180) with its O-ring into the vent-valve adapter T05 of the pressure test fixture
- Immerse the vent-valve assembly (180) in water and slowly raise the air pressure
- Test per table below, and change all vent-valve assemblies (180) that do not pass the test

Test	Check
O-ring	No distortion, split or cracks
Air pressure < 0.14 bar (2 psi)	Vent-valve is closed (no bubbles)
0.14 bar (2 psi) < air pressure < 0.7 bar (10 psi)	Vent-valve opens (bubbles observed)

Table 5003 - Vent-valve test

ASSEMBLY

1. Introduction

This section covers basic battery assembly procedures. In all cases, when reassembling a battery, all components should be clean and dry.

2. Safety

Refer to chapter [Safety](#) for caution, risks, and proper personal protective equipments (PPE).

3. Equipment

3-1. Standard tools

Refer to chapter [Standard tools](#) in [Special tools, fixtures, equipment and consumables](#).

3-2. Special tools

When special tools are used in this chapter, they are identified by a code number listed in [Special tools, fixtures, equipment and consumables](#) chapter.

4. Battery assembly

NOTE: All item numbers from the Illustrated Part List (IPL, Fig. 1) are referred by “(###)”. Item numbers are linked by hypertext to the IPL. Decimal of item numbers referred by “(###.#)” are for illustration aid only and are not listed in the IPL.

4-1. Installation of the sensor connector complete

CAUTION: CARE MUST BE TAKEN NOT TO PULL ON WIRES, TWIST OR BEND THE HEATER TABS BACK AND FORTH. DO NOT PINCH CABLE HARNESS AGAINST SHARP EDGES.

CAUTION: DO NOT PINCH CABLE HARNESS AGAINST SHARP EDGES.

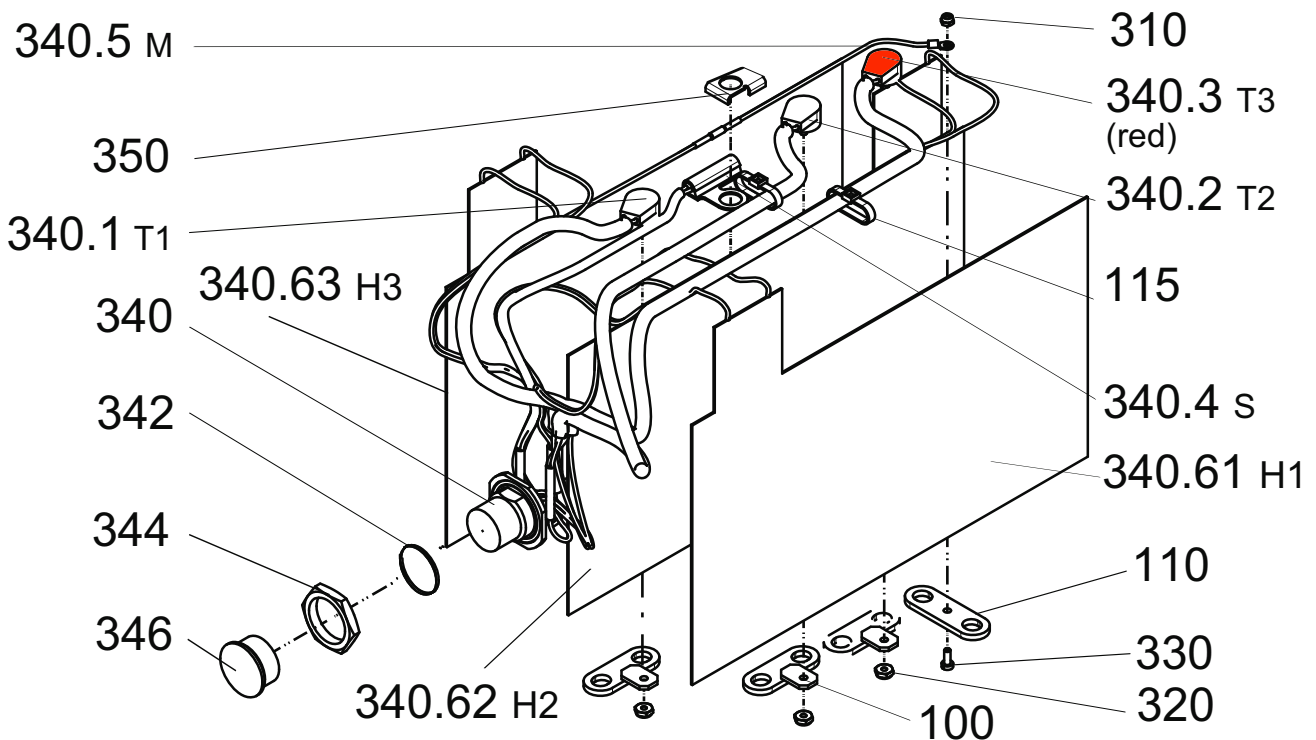

Figure 7001 - Sensor connector complete

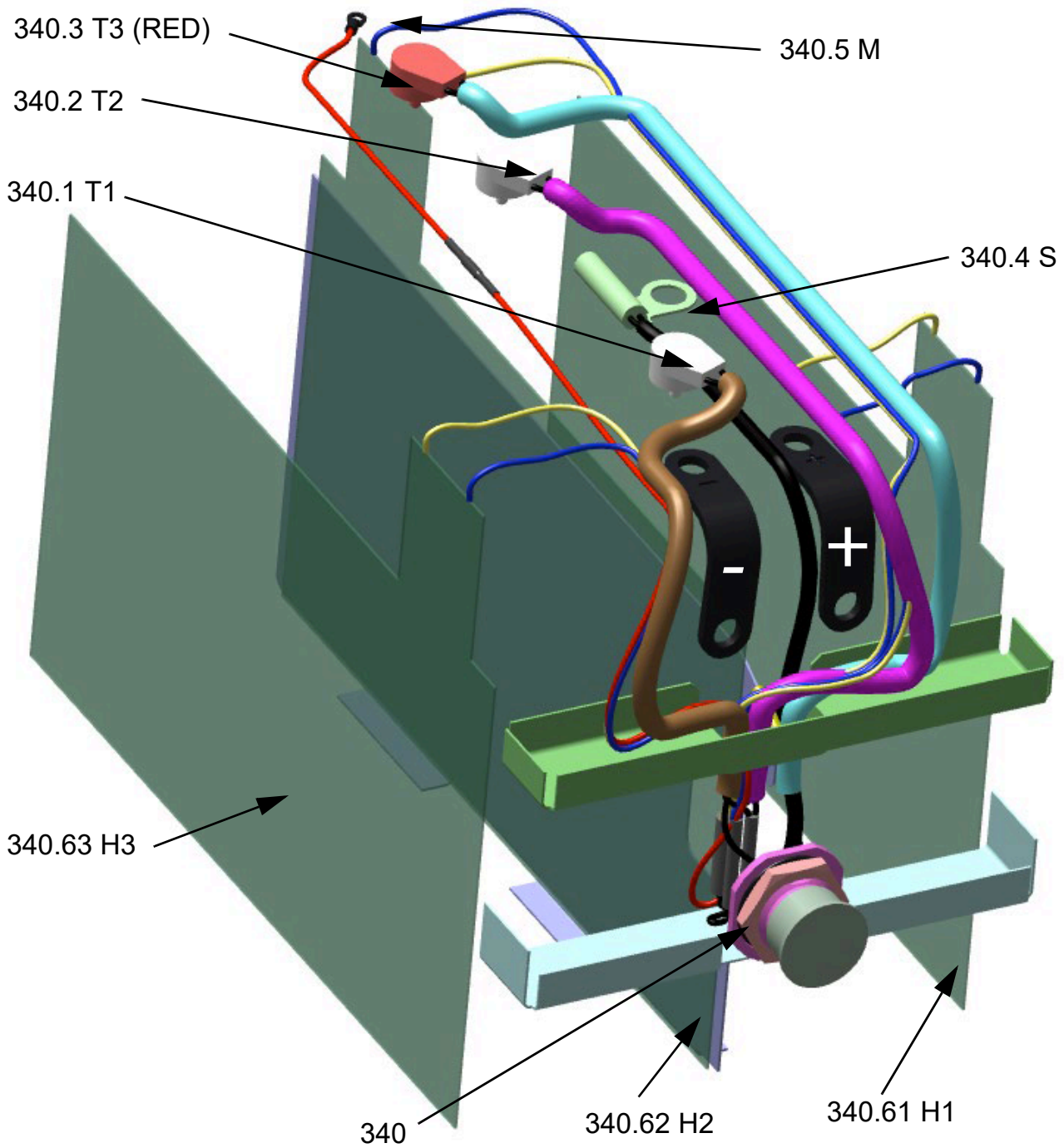

Figure 7002 - Sensor connector wire layout

NOTE: Figure [7002 - Sensor connector wire layout](#) is a partial view illustration aimed at supporting sensor harness installation in relation to the box assembly ([015](#)). Viewed from the outside front of the battery.

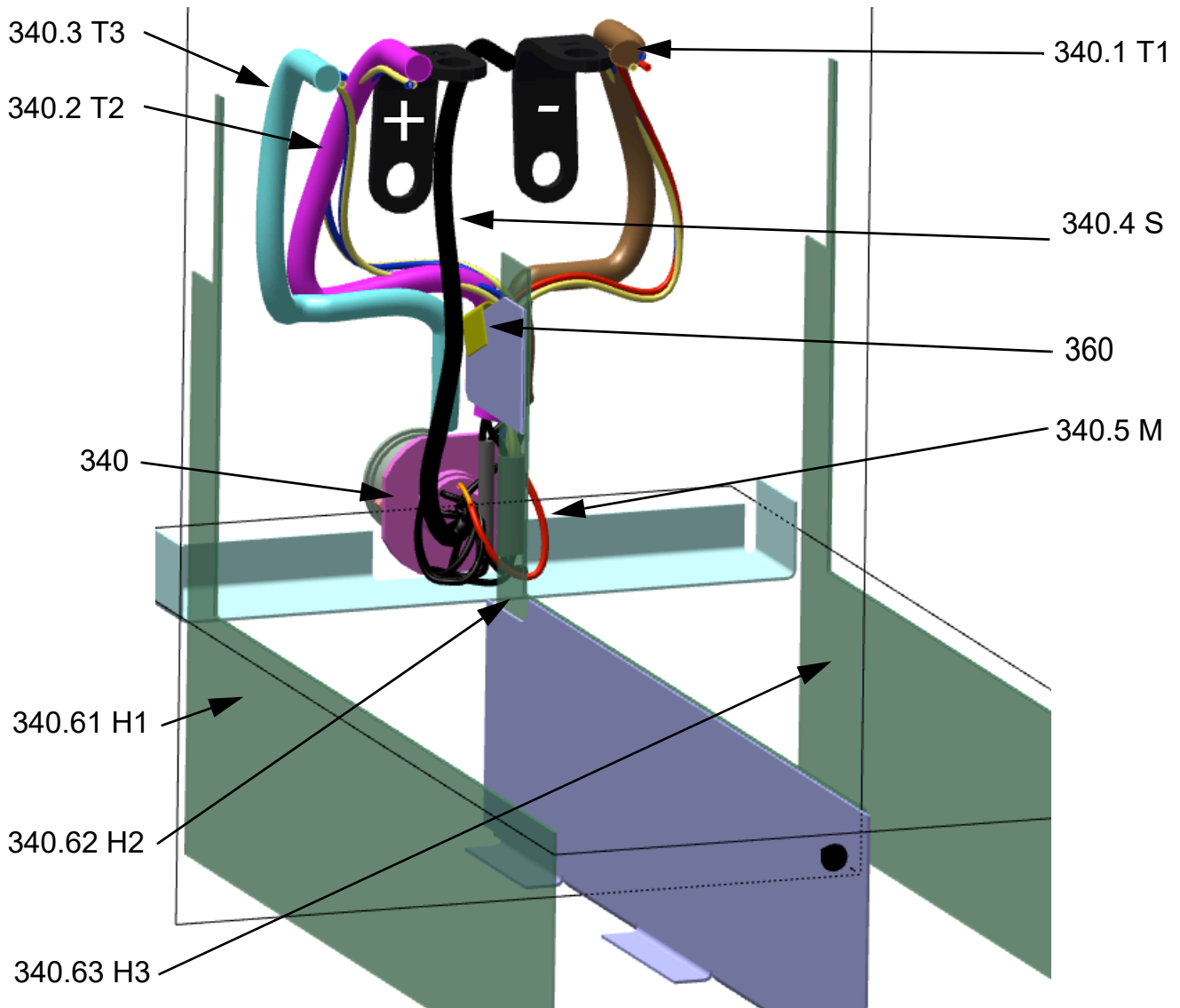

Figure 7003 - Sensor connector wire layout details

NOTE: Figure [7003 - Sensor connector wire layout details](#) is a partial view illustration aimed at supporting sensor harness installation in relation to the box assembly ([015](#)). Viewed from the inside rear side of the battery with partial views of the heaters and box partition wall.

Install the partition edge protector ([360](#)) on the box partition (per figure: [7002 - Sensor connector wire layout](#) and [7003 - Sensor connector wire layout details](#)).

NOTE: Handle sensor connector complete ([300](#)) with care to prevent damage to the wire sensor (340.1 to 340.5) and heater tabs (340.61 to 340.63) (per figure: [7001 - Sensor connector complete](#) and [7002 - Sensor connector wire layout](#)).

NOTE: In order to properly locate each wire and component of the sensor connector assembly ([340](#)), each assembly step must be strictly followed in the order provided.

NOTE: The heaters H1, H2, H3 (340.61 to 340.63) will be installed once the liner-spacer kit ([190](#)) is in place. Do not install heaters at this time.

Component Maintenance Manual 170CH-1

Install the connector of the sensor connector assembly (340) and sensor connector O-ring (342) from the **inside NEGATIVE SIDE compartment** of the box assembly (015).

Install the nut (344) from outside the box assembly (015). Torque the nut (344) according to [Fits and clearances](#) chapter.

Thread ONLY the thermostats T3 (340.3) and thermistor S (340.4) through the mid wall partition and onto the positive side compartment of the box assembly (015) per figure [7002 - Sensor connector wire layout](#) and [7003 - Sensor connector wire layout details](#).

NOTE: This assembly is a tight fit. Care must be taken during threading of the thermostat T3 (340.3) and the thermistor S (340.4) through the box partition hole.

NOTE: The rest of the sensor connector assembly (340) remains on the negative side compartment of the box assembly (015).

Thermostats T2 (340.2) and heaters H1 and H2 (340.61 and 340.62) are moved above the box partition from the negative side to the positive side of the battery box.

NOTE: Ensure partition edge protector (360) on the box partition is properly located and directly under the Thermostat T2 (340.2) and heater wires (340.61 and 340.62).

Set aside thermostats T1 to T3 (340.1 to 340.3), thermistor S (340.4), midpoint voltage M (340.5), and heaters H1 to H3 (340.61 to 340.63) per figure [7002 - Sensor connector wire layout](#) and [7003 - Sensor connector wire layout details](#).

4-2. Construction and installation of the power connector

Lightly lubricate the nuts (230), the washers (240 and 270), and the links (250 and 260), with [M02](#) (use a non-metallic paintbrush).

On the power connector assembly (280) positive terminal, install the washer (270), the link (250), the lock washer (240), and the nuts (230).

On the power connector assembly (280) negative terminal, install the washer (270), the link (260), the lock washer (240), and the nuts (230).

NOTE: Make sure the links (250 and 260) are carefully oriented vertically.

Torque the nuts (230) according to [Fits and clearances](#) chapter.

Lightly lubricate the nuts (230) and the lock washers (270) assembly with [M02](#) (use a non-metallic paintbrush).

Install the power connector complete (220) and O-ring (290) from outside the box assembly (015) into position using the screws (200) and the washers (210) per figure [JPL-1 - 170CH-1 Nickel-Cadmium Aircraft Battery](#). Torque the screws (200) according to [Fits and clearances](#) chapter.

NOTE: Make sure all the wires of the sensor connector assembly are free of pinch and kept below the power connector. All wires should be able to move freely.

NOTE: Make sure the thermistor S (340.4) is properly located between the center of the power connector complete (220) and the positive link (250) of the power connector complete (220) positive terminal (per figure [7002 - Sensor connector wire layout](#) and [7003 - Sensor connector wire layout details](#)).

Install the power connector cover (295).

4-3. Installation of the liner-spacer kit

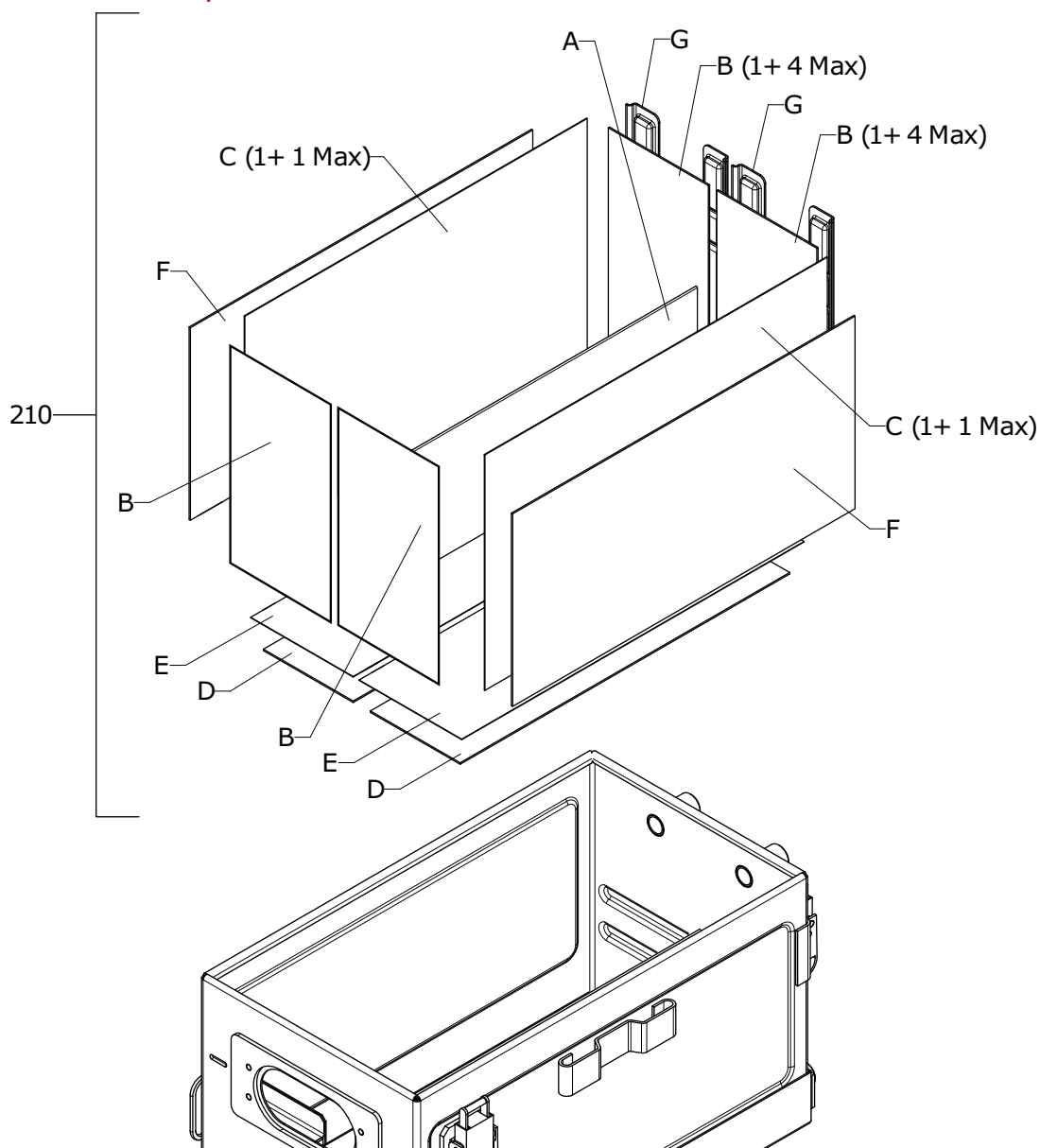

Figure 7004 - Liner-spacer kit

Item	Description	Dimension (mm)	Unit per assembly
A	Liner-spacer	260 x 166 x 0.3	1
B	Liner-spacer	130 x 78 x 1.0	14
C	Liner-spacer	267 x 159 x 0.5	4
D	Liner-spacer	257 x 70 x 1.0	2
E	Liner-spacer	267 x 80 x 0.3	2
F	Liner-spacer	267 x 130 x 1.0	2
G	Liner-spacer, molded	78 x 158 x 5.0	2

Component Maintenance Manual 170CH-1

CAUTION: MAKE SURE LINER-SPACERS OR HEATER TABS DO NOT OBSTRUCT THE BOX ASSEMBLY (015) VENT PORTS.

NOTE: Ensure the partition edge protector (360) is in position per figure [7003 - Sensor connector wire layout details](#).

Install the liner-spacer kit (190) in position as illustrated by figure [7004 - Liner-spacer kit](#).

NOTE: Liner-spacer kit (190) is used to make sure the cell assemblies (120) are tightly held in place. Adjust liner-spacer count as necessary.

NOTE: In order to properly locate each wire and component of the sensor connector assembly (340), each assembly step must be strictly followed in the order provided.

First locate the side heaters H1 and H3 (340.61 and 340.63) as illustrated in figure [7002 - Sensor connector wire layout](#).

Then locate the central heater H2 (340.62) on negative side section of the box assembly (015) as illustrated in figure [7002 - Sensor connector wire layout](#)

NOTE: To facilitate installation and positioning of the liner-spacer kit (190) and heaters H1 to H3 (340.61 to 340.63) use cell assemblies (120) at both ends of each rows.

4-4. Installation of the cell assemblies

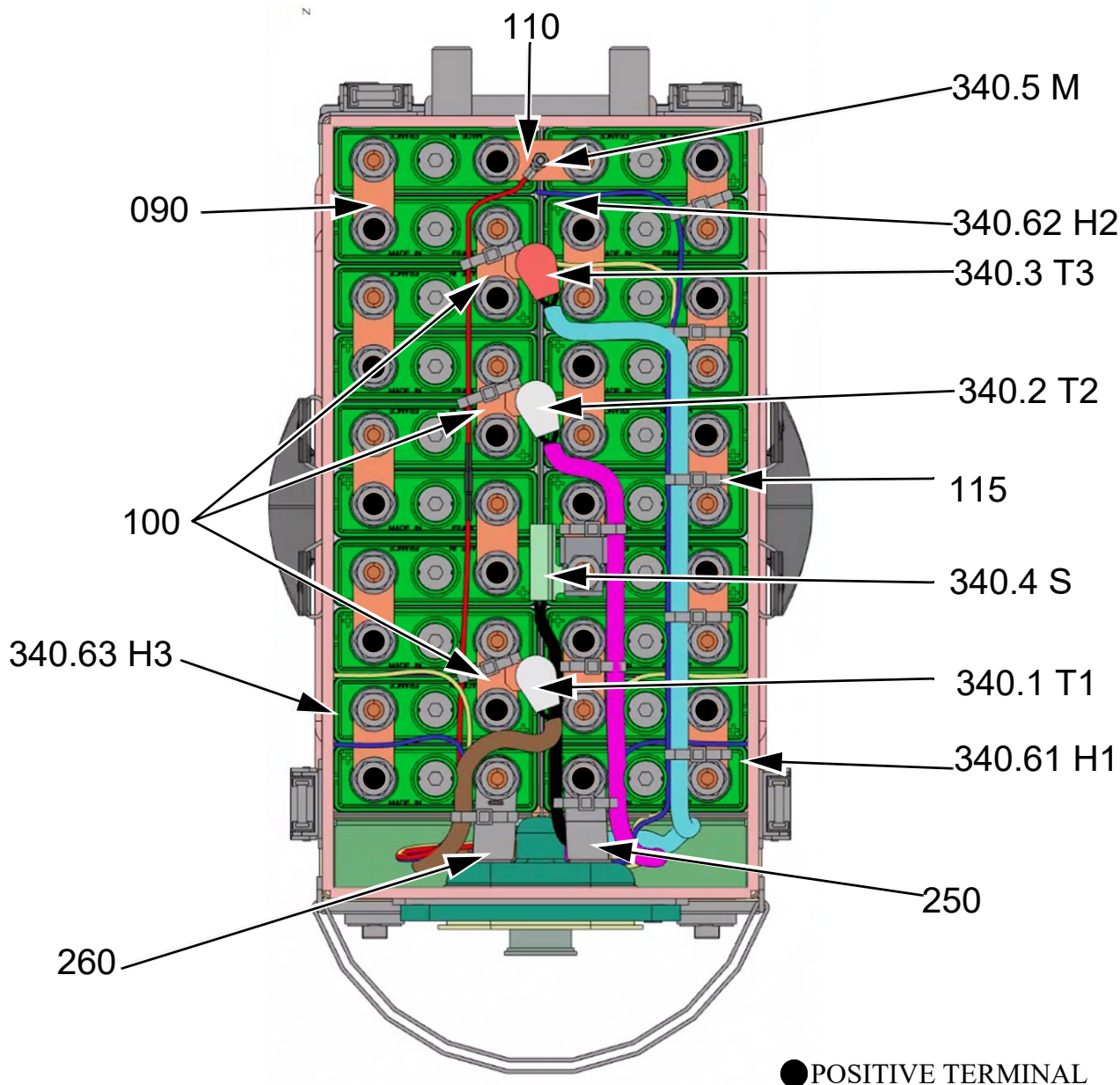

Figure 7005 - Battery layout

CAUTION: DO NOT BEND HEATER TABS (340.61 to 340.63) EXCESSIVELY.

CAUTION: DO NOT PINCH CABLE HARNESS AGAINST SHARP EDGES OR BETWEEN HARDWARE.

CAUTION: MAKE SURE CELL POLARITIES ARE CORRECT, DOUBLE CHECK CELL ORIENTATIONS PER FIGURE [7005 - Battery layout](#)

NOTE: In order to properly locate each wires and components of the sensor connector assembly ([340](#)) each assembly steps must be strictly followed in the order provided.

NOTE: To facilitate cell installation and make sure cell orientation is respected, layout the cells outside the box assembly per figure [7005 - Battery layout](#).

Install the remaining cell assemblies ([120](#)) starting from the end of each rows following the polarity orientation per figure [7005 - Battery layout](#).

Install the last cells into position by pushing onto both cell terminals at once using a block of soft wood (if the cell insertion is too difficult, remove one or two partition end liner-spacers).

Verify, once again, the polarity of each cells per figure [7005 - Battery layout](#).

NOTE: Make sure that the cell terminal's lower nuts ([135](#)) is torqued per [Fits and clearances](#) chapter.

Lightly lubricate the cell assembly ([120](#)) terminals, the nuts ([130](#) and [135](#)), washers ([140](#) to [170](#)), the stirrup ([350](#)), and the links ([090](#) to [110](#)) with [M02](#) (use a non-metallic paintbrush).

Install the midpoint sensor M (340.5) on the link ([110](#)) using nut ([310](#)). Torque the nut ([310](#)) per [Fits and clearances](#) chapter.

Install the link ([110](#)) equipped with the midpoint sensor M (340.5) on the cell assemblies ([120](#)) per figure [7005 - Battery layout](#).

NOTE: Make sure the midpoint sensor M (340.5) wire is threaded **under** the heater wires H3 (340.63) and the thermostat T1 (340.1) per figure [7005 - Battery layout](#).

Install the washers ([160](#)) and the nuts ([130](#)) finger tight.

Install all the links ([090](#)) on the cell assemblies ([120](#)) per figure [7005 - Battery layout](#).

NOTE: Make sure to thread the heater wires (340.61 to 340.63) **above** each links ([090](#)) per figure [7005 - Battery layout](#).

Install the washers ([160](#)) and the nuts ([130](#)) finger tight.

Temporarily remove the nut ([130](#)) and washer ([160](#)) to install the thermistors S (340.4) with stirrup ([350](#)) per figure [7005 - Battery layout](#).

Re-install the washer ([160](#)) and the nut ([130](#)) finger tight.

Install the thermostats T1 (340.1), T2 (340.2), and T3 (340.3) on the links ([100](#)) using nuts ([320](#)). Torque the nuts ([320](#)) according to [Fits and clearances](#) chapter.

Install the link ([100](#)) and thermostat T1 (340.1) assembly on the cell assemblies ([120](#)) per figure [7005 - Battery layout](#).

NOTE: Do not pinch cable harness against sharp edges or between hardware, wires should be able to move freely before the installation of the wire ties.

Install the washers ([160](#)) and the nuts ([130](#)) finger tight.

Install the link ([100](#)) and the thermostat T2 (340.2) assembly on the cell assemblies ([120](#)) per figure [7005 - Battery layout](#).

Install the washers ([160](#)) and the nuts ([130](#)) finger tight.

Install the link ([100](#)) and the thermostat T3 (340.3) assembly on the cell assemblies ([120](#)) per figure [7005 - Battery layout](#).

Install the washers ([160](#)) and the nuts ([130](#)) finger tight.

Install the washers ([080](#)) and the nuts ([070](#)) on the power connector links ([250](#) and [260](#)).

Torque the nuts ([130](#)) according to [Fits and clearances](#) chapter.

Lightly lubricate the nuts ([130](#)), washers ([140](#) to [170](#)), and stirrup ([350](#)) with [M02](#) (use a non-metallic paintbrush).

Install the cable ties ([115](#)) making sure the cables are not pinched, strictly respect the cable path per figure [7005 - Battery layout](#).

Install the cover complete ([020](#)) and attach it.

4-5. Installation of the box mounting brackets

Install the box mounting brackets ([017](#)).

Apply one drop of thread-locking adhesive ([M04](#)) to the screws' ([019](#)) thread.

Install the screws ([019](#)).

Torque the screws ([019](#)) according to [Fits and clearances](#) chapter.

4-6. Recording

Fill out the log book or equivalent.

FITS AND CLEARANCES

1. Introduction

The torque values below are "lubricated torque" values.

Use [M02](#) to lightly grease the terminal and nut threads before assembly and torque.

Vent-valves should be finger tightened using Saft universal vent-valve wrench [T01](#), or tightened to the torque value listed in the table.

2. Torque table

IPL FIG ITEM N°	NAME	TORQUE VALUE	
		N.m	lbf.in
019	Screw, F/90 M 4X8	2.0 to 2.5	18 to 22
070 , 130	Upper nut, M8 x 1.25	7.0 to 9.0	62 to 80
135	Lower nut, M8 x 1.25	4.5 to 5.5	40 to 49
180	Vent-valve, M8	0.29 to 0.31 (finger tight)	2.57 to 2.74 (finger tight)
200	Power connector screw, F/90 M4 x 0.7-10	2.0 to 2.5	18 to 22
230	Power connector assembly nut 5/16-18-UNC-2B,	6.5 to 7.5	57 to 66
310	Sensor connector nut, M3	0.3 to 0.7	3 to 6
320	Thermostat nut, #6-32"	1.0 to 1.2	9 to 11
330	Sensor connector screw, M3 x 8	0.3 to 0.7	3 to 6
344	Sensor connector nut D38999-28-3J	5.6 to 6.9	50 to 61

Table 8001 - Torque table



**Component Maintenance Manual
170CH-1**

PAGE INTENTIONALLY LEFT BLANK

SPECIAL TOOLS, FIXTURES, EQUIPMENT AND CONSUMABLES

1. Introduction

This chapter is divided into two parts:

- The first part provides the list of special tools, fixtures and equipment needed to do the steps listed in the other chapters
- The second part provides the listing of consumables used in this manual

All listed items are identified in this manual by a standard code number:

- Txx for tools, fixtures and equipment
- Mxx for consumable materials

2. Standard tools

The following items are recommended to do the procedures described in this manual. When necessary, equivalent substitutes may be used.

- Safety gloves
- Protective goggles
- Safety shoes
- Eye wash
- Protective apron
- Constant current charger (DC current range 0-60 A, minimum open DC voltage 40 V)
- Constant current load bank (DC current range 0-60 A, DC voltage range 1-40 V)
- Meg-ohmmeter (0-50 MΩ @ 250 V DC)
- Multimeter (Volt, Ω, mA) 3.5 digits 2,000 counts 3.5 digits 1 % or better
- Climatic chamber
- Torque wrench (insulated) 0-15 N.m (0-133 lbf.in)
- Standard mechanic's tools (insulated)
- Stiff bristle brush (non-metallic)
- Small paintbrush (non-metallic)
- Dry, compressed air source [less than 1.4 bar (20 psi)]
- Soft, lint free, clean cloth (at least two required)

3. Special tools

NOTE: Equivalent tools can be used.

A special tool kit (P/N 416161) is available from Saft containing special tools including; T01, T02, T03, and T04. The tools are housed in a polypropylene box and each tool is insulated to optimize safety for the technician.

TOOL CODE	DESCRIPTION	(F6177) P/N	(09052) P/N
T01	Universal vent valve wrench	413876	093365-000
T02	Syringe assembly with M8, 20 mm (0.79 in) nozzle	416231 (assembly of 105112 & 016544)	020915-004
T03	1.2 Ω 3 W equalizing resistors	164829	022069-000
T04	Universal or M10 cell extraction tool	416159	017556-000
T05	Vent-valve testing adapter for M8 valve	458723	025098-000

Table 9001 - Special tools

4. Consumables

NOTE: Equivalent alternatives can be used for list items.

This paragraph describes the consumables used in the CMM.

MATERIAL CODE	DESIGNATION PART NUMBER AND SPECIFICATION	MANUFACTURER OR SUPPLIER (NAME, ADDRESS, CODE)
M01	Distilled or deionized water (specification at +20 °C (+68 °F)): clear, colorless and odorless while boiling Conductivity < 33 µS/cm 5 < pH < 7 Mn-COD < 30 mg/l (1.7 X 10 ⁻⁵ oz/in ³)(Chemical Oxygen Demand under potassium permanganate methodology): methodology to evaluate organic or mineral pollution) Chlorines Cl- < 5 mg/l (2.9 X 10 ⁻⁶ oz/in ³) Sulfates SO4-- < 10 mg/l (5.8 X 10 ⁻⁶ oz/in ³) Temperature for analysis and specifications are at +20 °C (+68 °F). STORAGE: dry and clean container without any corrosion and damage; Temperature: +15 °C to +20 °C (+56 °F to +80 °F). Over 1 year of storage, do an analysis of the liquid.	Local vendor or in house production
M02	Neutral petroleum jelly Density @ +60 °C (+140 °F) range = 0.840 - 0.866 kg/l (0.486 - 0.500 oz/in ³) Melting Point Range = +46 °C to +52 °C (+115 °F to +126 °F) Acidity/Alkalinity = Neutral to litmus	Mineral vaseline NATO: S 743 F: AIR 3565 US: VV-P-236A UK: DEF 2333
M03	Mild soap (6.5 < pH < 7.5)	Local vendor
M04	Thread-locking adhesive Mil-S-46163A Type I Grade K example: Loctite 271 © or equivalent	Local vendor
M05	Mild solvent (ethanol)	Local vendor

Table 9002 - Consumable materials

ILLUSTRATED PARTS LIST

1. Introduction

1-1. General

The Illustrated Parts List (IPL) contains a list and illustrations of the assemblies and detailed parts of the unit in disassembly sequence.

To find the illustration for a part if the part number is known, refer to the [Alpha numerical index](#) and look for the part number and the corresponding figure and item number. Refer to the [Detailed part list](#) and look for the first figure and item number found in the [Alpha numerical index](#) for that part. If this figure shows the part in a section or system of the equipment other than the one necessary, refer to the other figure numbers listed in the Numerical Index.

To determine the part number of a given part, refer to the illustration showing the assembly including this part. Note the item number of the illustrated part and refer to the [Detailed part list](#) which indicates its part number and identification.

1-2. Alpha numerical index

In this index, part numbers are classified from left to right, each character (letter, number, hyphen) being considered separately.

The part number column contains all part numbers included in the [Detailed part list](#).

1-3. Detailed parts list

1-3-1. Figure and Item Number

Each assembly, sub-assembly and parts with a part number that is included in the parts list is given as an item number.

The figure number linked to the item number is shown on the first line at the top of each page.

Numbered parts of assemblies and sub-assemblies included in the list but not illustrated are identified by a hyphen (-) preceding the item number.

An index letter shown before the item number refers to the figure showing the modified portion of the applicable part.

Manufacturer's Part Number: a manufacturer's part number is given to each assembly and detail part, whether illustrated or not.

Nomenclature: the nomenclature is given with an indenture, to show how the parts and the assemblies are related to the overall assembly. These are the details:

1 2 3 4 5 6 7

Assembly

. Detailed parts for assembly

. Sub-assembly

. Attaching parts and/or storage parts for sub-assembly

. . Detailed parts for sub-assembly

. . Sub-sub-assembly

. . Attaching parts and/or storage parts for sub-sub-assembly

. . . Detailed parts for sub-sub-assembly

The attaching parts are shown directly after the assembly of the part thereof. They are listed under the same indent number as the item they are attached to, are identified by the words "Attaching Parts" and are followed by three asterisks.

The manufacturer's code or the abbreviation NP (not procurable) are placed at the extreme right-hand side of the first line of the parts list column.

Component Maintenance Manual 170CH-1

1-3-2. Effectivity code

A numerical index indicates the effectivity of sub-assemblies and detailed parts lists in relation to the next level assembly (ies) or sub-assembly (ies).

When the effectivity is fully applicable, the usage code column remains blank.

The use code for assemblies and detailed parts refers to the figure/item number of the next higher assembly (ies) or sub-assembly (ies). Example: Effectivity 1A, 1B, 1C is written 1ABC.

1-3-3. Units per Assembly

The units per assembly column shows the quantity of units required for one next level assembly.

In some cases, the information is replaced by the abbreviation RF (for reference) or AR.

2. Alpha numerical index

Part Number	Airline Stock Number	Figure Number	Item Number	Quantity per Battery
AS3582-026		IPL-1	342	1
D38999-28-3J			344	1
MS18034-4			115	12
MS90376-14R			346	1
080010			185	20
100111			080, 160, 240	84
100430			210	4
100431			200	4
100479			170, 270	42
100593			187	20
100695			140	20
100696			150	20
100713			290	1
101229			090	15
105405			320	3
108045			330	1
114735			110	1
116585			019	4
163366			400	1
163367			390	1
164583			360	1
164790			310	1
166309			410	2
166925			295	1

Component Maintenance Manual 170CH-1

Part Number	Airline Stock Number	Figure Number	Item Number	Quantity per Battery
280068			440	1
411715			280	1
411810			070, 130	42
412488			050	2
413445			135	40
413607			430	2
413609			420	2
413652			-001	RF
413824			017	2
413835			300	1
413865			030	1
413871			120	20
413888			040	1
413909			340	1
413911			350	1
413918			015	1
413925			190	1
413927			010	1
413931			020	1
413980			060	1
413982			100	3
414185			250	1
414186			260	1
414202			220	1
414252			230	2
415215			180	20

-: Item not illustrated

RF: For reference purpose

3. Detailed part list

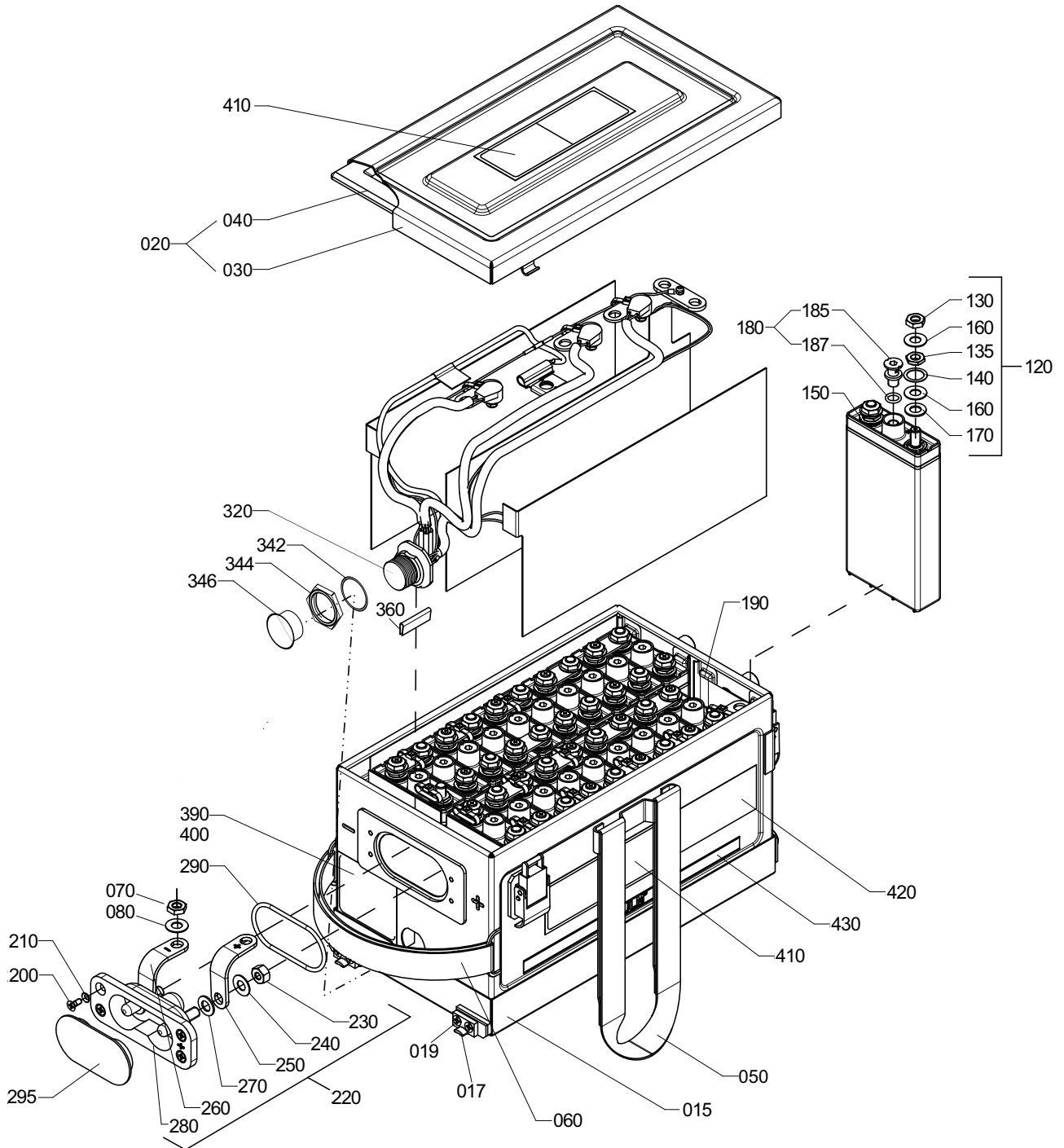

Figure IPL-1 - 170CH-1 Nickel-Cadmium Aircraft Battery

Component Maintenance Manual 170CH-1

Figure Number	Item Number	Part Number	Airline Stock Number	Nomenclature							Unit per assembly
				1	2	3	4	5	6	7	
IPL-1	-001	413652		BATTERY 170CH-1 , WITH CVH175KH CELLS							RF
	010	413927		. BOX AND COVER COMPLETE							1
	015	413918		.. BOX ASSEMBLY							1
	017	413824		... BOX MOUNTING BRACKET							2
	019	116585		... SCREW, F/90 M 4X8							4
	020	413931		.. COVER COMPLETE							1
	030	NONPROC1		... COVER ASSEMBLY							NP 1
	040	NONPROC2		... COVER GASKET							NP 1
	050	412488		.. HANDLE STRAP							2
	060	413980		.. HANDLE STRAP							1
	070	411810		. NUT, M8 X 1.25							2
	080	100111		. WASHER SPRING							2
	090	101229		. LINK INTERCELL, E27							15
	100	413982		. LINK INTERCELL, E27							3
	110	114735		. LINK INTERCELL, E33							1
	115	MS18034-4		. CABLE TIE (F6177 PN:116056)							12
	120	413871		. CELL CVH175KH ASSEMBLY							20
	130	411810		.. UPPER NUT, M8 X 1.25							2
	135	413445		.. LOWER NUT, M8 X 1.25							2
	140	100695		.. WASHER POSITIVE POLARITY							1
	150	100696		.. WASHER NEGATIVE POLARITY							1
	160	100111		.. WASHER SPRING							4
	170	100479		.. WASHER FLAT							2
	180	415215		.. VENT-VALVE ASSEMBLY							1
	185	080010		... VENT-VALVE							1
	187	100593		... VENT-VALVE O-RING							1
	190	413925		. LINER-SPACER KIT							1
	200	100431		. SCREW, F/90 M4 X 10							4
	210	100430		. WASHER LOCK, M4							4
	220	414202		. POWER CONNECTOR COMPLETE							1
	230	414252		.. POWER CONNECTOR NUT, 5/16-18-UNC-2B							2
	240	100111		.. WASHER SPRING							2
	250	414185		.. LINK POSITIVE							1
	260	414186		.. LINK NEGATIVE							1

Component Maintenance Manual 170CH-1

Figure Number	Item Number	Part Number	Airline Stock Number	Nomenclature							Unit per assembly	
				1	2	3	4	5	6	7		
	270	100479		.	.	WASHER	FLAT					2
	280	411715		.	.	POWER CONNECTOR ASSEMBLY (RECEPTACLE CONFORMING TO MIL STD MS3509)						1
	290	100713		.	POWER CONNECTOR GASKET							1
	295	166925		.	POWER CONNECTOR COVER							1
	300	413835		.	SENSOR CONNECTOR COMPLETE							1
	310	164790		.	NUT, M3							1
	320	105405		.	NUT, 6/32"							3
	330	108045		.	SCREW, CL M3 X 8							1
	340	NONPROC3		.	SENSOR CONNECTOR ASSEMBLY					NP		1
	342	AS3582-026		.	SENSOR CONNECTOR O-RING					NP		1
	344	D38999-28-3J		.	SENSOR CONNECTOR NUT					NP		1
	346	MS90376-14R		.	SENSOR CONNECTOR COVER					NP		1
	350	413911		.	STIRRUP							1
	360	164583		.	PARTITION EDGE PROTECTOR							1
	390	163367		.	FILM PROTECTOR							1
	400	163366		.	PLATE IDENTIFICATION							1
	410	166309		.	PLATE FILLING INSTRUCTION							2
	420	413609		.	PLATE SAFT LABEL							2
	430	413607		.	PLATE RANGE LABEL							2
	440	280068		.	PLATE RECYCLING							1

-: Item not illustrated

NP: Not Procurable

RF: For reference purpose

STORAGE (INCLUDING TRANSPORTATION)

1. Introduction

1-1. General

This document describes different methods of storage conditions recommended for a battery which has been cleaned and serviced and is not immediately placed in service on-board an aircraft.

Proper storage conditions and packaging makes sure that the equipment is protected against environmental damages.

1-2. Storage room

Keep the batteries and spares in a dry and clean room isolated from detrimental agents such as: dirt, dust, dampness, vibration, and corrosive atmosphere.

Lead-acid batteries must not be stored in the same room as Saft Ni-Cd batteries.

1-3. Climatic conditions

The recommended temperature range is $+20\text{ }^{\circ}\text{C} \pm 15\text{ }^{\circ}\text{C}$ ($+68\text{ }^{\circ}\text{F} \pm 27\text{ }^{\circ}\text{F}$).

Pressure 750 to 1060 hPa (22.15 to 31.3 in.Hg).

Relative humidity < 85 %.

2. Storage

2-1. Inactive long-term storage

2-1-1. Procedure

Before placing a battery into inactive long-term storage, the battery must successfully complete [Regular check](#) or [General overhaul](#) and be in a discharged condition (refer to [Residual discharge](#) and [Cell shorting](#)). There is no need of maintenance operation during the storage period. It is not necessary to short circuit the battery. No revalidation is required during the storage.

NOTE: If [Climatic conditions](#) are met and the packaging protects the battery from mechanical damages, environmental contaminants (i.e.: dirt, dust, vibrations, or corrosive atmosphere), and is airtight, then a 10 year storage period is allowed (if not airtight, a 2 year storage period is allowed).

The batteries are stored in a normal vertical position as described in paragraphs [Storage room](#) and [Climatic conditions](#).

2-1-2. Action at the end of long-term storage

For batteries under long-term storage and before installation of the battery into the aircraft for service:

- If storage time is less than or equal to 12 months, then do [Visual inspection](#), [Insulation check](#), [Nut tightness](#), [Charge](#), [Adjust electrolyte level](#), and repeat [Insulation check](#).
- If storage time is over 12 months do [Charge](#) followed by [Regular check](#).

2-2. Inactive standby storage

2-2-1. Scope

The inactive standby storage allows the battery to be stored in a "ready to be installed on the aircraft" condition.

2-2-2. Procedure

CAUTION: IF THE FOLLOWING CONDITIONS ARE NOT MET, THERE IS A RISK OF PLACING A BATTERY ON BOARD AN AIRCRAFT THAT DOES NOT MEET THE EMERGENCY REQUIREMENTS.

NOTE: The temperature is the average temperature during the storage period.

NOTE: If the battery was previously stored at a temperature below the ambient temperature, condensation may occur. Before installing do [Insulation check](#).

Maintain the battery per CMM procedures. Store the battery fully charged (refer to [Charge](#)) in a dedicated room (refer to [Storage room](#) and [Climatic conditions](#)) to be able to be installed in the aircraft without further check any time during an inactive standby storage period. The battery may be kept in inactive standby storage for a period of 90 days maximum corresponding to 80 % available capacity (refer to figure [15001 - Standby storage period](#)).

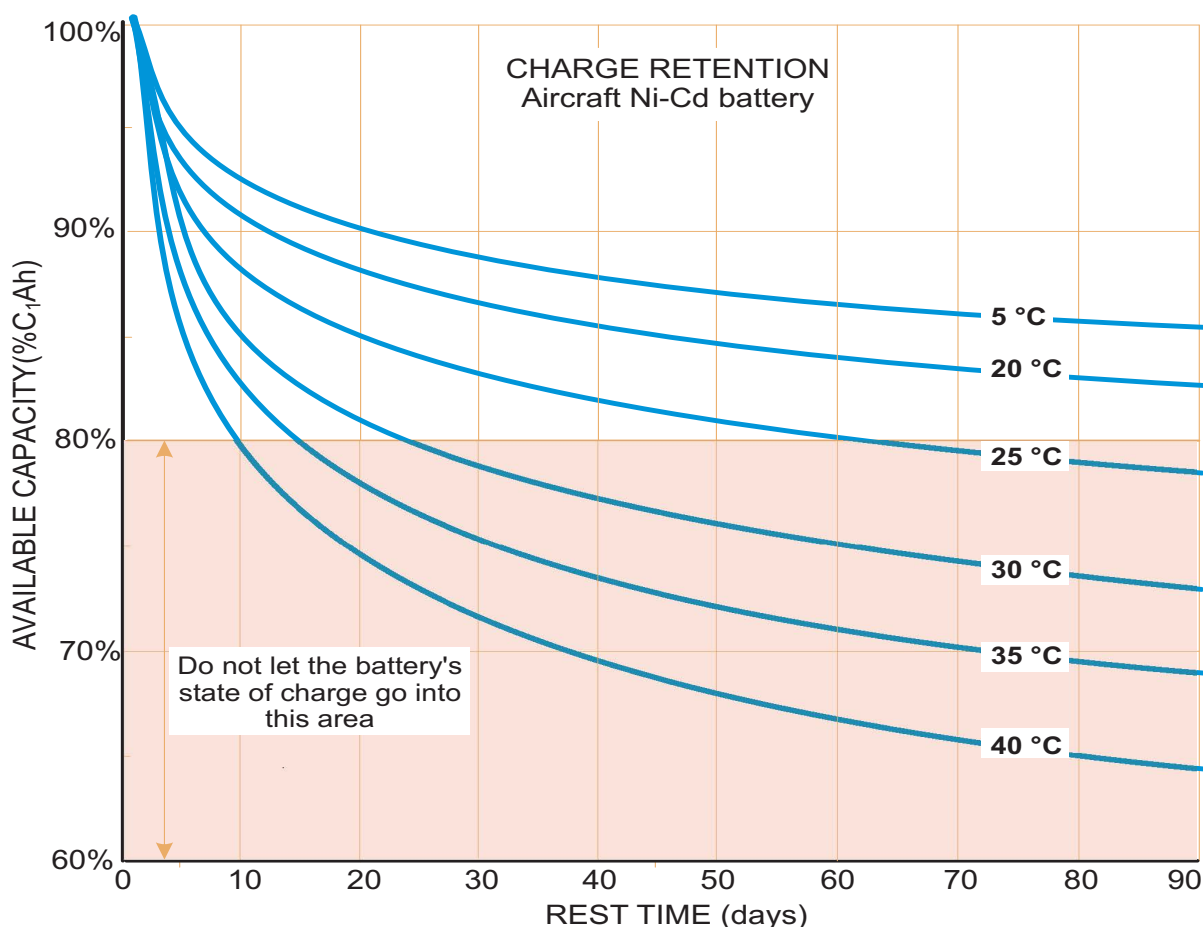

Figure 15001 - Standby storage period

2-2-2-1. Definitions

- The [inactive standby storage](#) period is a maximum 90 days (3 months) for average room temperature < +23 °C (+73.4 °F)
- Total standby storage duration is 9 standby storage periods or 810 days (27 months)

2-2-2-2. Examples of standby storage period

- 24 days at an average room temperature of +30 °C (+86 °F)
- 60 days at an average room temperature of +25 °C (+77 °F)

2-2-3. Refresh charge

The [inactive standby storage](#) period can be prolonged by applying refresh charge (at the end of the period). The refresh charge is defined as a short charge at 0.1C₁A, 0.5C₁A, or 1C₁A until the voltage reaches the values given in the Table [15002 - Inactive standby storage](#) below.

CHARGE rate	VOLTAGE (end of refresh charge)
0.1 C ₁ A (1.7 A)	1.50 V x 20 cells
0.5 C ₁ A (8.5 A)	1.55 V x 20 cells
1.0 C ₁ A (17 A)	1.57 V x 20 cells

Table 15001 - Charge rate for refresh charge

The battery can receive the refresh charge two (2) times maximum during each standby storage period. The time necessary to reach the required voltage should be very short. **Do not overcharge at 0.1C₁A for 4 hours.**

2-2-4. Action at the end of standby storage periods (refer to figure [15002 - Inactive standby storage](#))

NOTE: During any standby storage periods the battery is serviceable.

Component Maintenance Manual 170CH-1

2-2-4-1. At the end of standby storage period 1, 2, 4, 5, 7, or period 8

- Do a [Refresh charge](#) and continue 1 more standby storage period
- Or install the serviceable battery into the aircraft without any further maintenance
- Or place the battery into [Inactive long-term storage](#) refer to the procedure

2-2-4-2. At the end of standby storage period 3 and period 6

- Install the serviceable battery into the aircraft without any further maintenance
- Or continue standby storage:
 - if the temperature is $\leq +30\text{ }^{\circ}\text{C}$ ($+86\text{ }^{\circ}\text{F}$), do [Insulation check](#) + [Residual discharge](#) + [Charge](#) + [Adjust electrolyte level](#) + [Insulation check](#) to continue [Inactive standby storage](#)
 - if the temperature is $> +30\text{ }^{\circ}\text{C}$ ($+86\text{ }^{\circ}\text{F}$) then do a [Regular check](#) to continue [Inactive standby storage](#)
- Or place the battery into [Inactive long-term storage](#)

2-2-4-3. At the end of standby storage period 9

- Install the serviceable battery into the aircraft without any further maintenance
- Or do a [Regular check](#) and place the battery into [Inactive long-term storage](#)

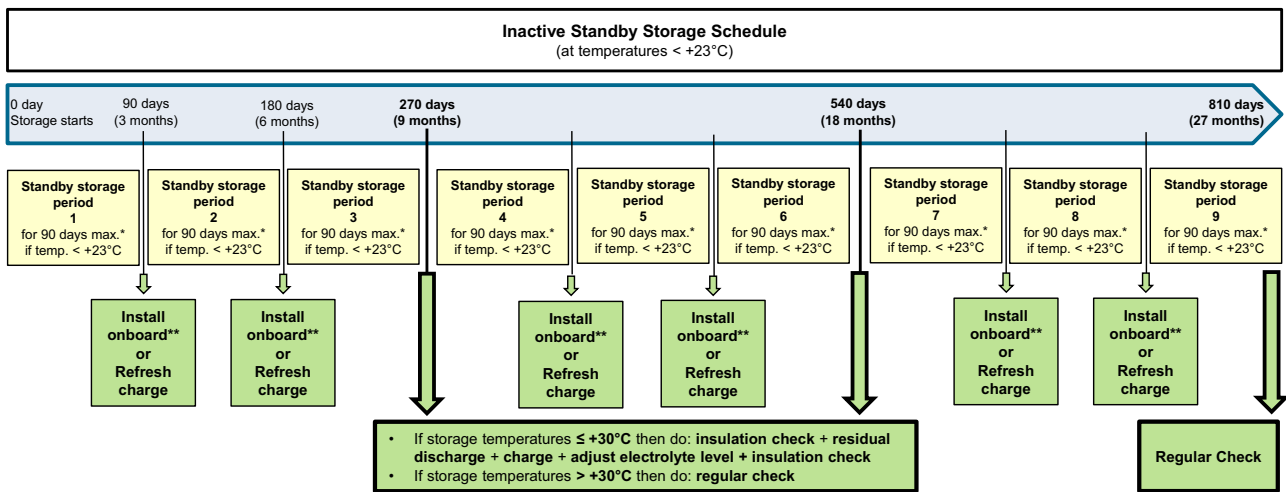

* If temperatures are $\geq +23\text{ }^{\circ}\text{C}$ standby storage periods will be shorter, refer to Figure 15001
 ** The battery can be installed on board the aircraft at any time during the standby storage period

Figure 15002 - Inactive standby storage

2-2-4-4. Example (figure 15002 - Inactive standby storage)

NOTE: Standby storage period is shorter if the temperature is higher; refer to figure 15001 - [Standby storage period](#) to adjust the standby storage period duration based on average storage room temperature.

- The initial standby storage period @ $+20\text{ }^{\circ}\text{C}$ ($+77\text{ }^{\circ}\text{F}$) of a fully charged battery is 90 days (3 months) maximum without any other required operations the capacity will remain over 80 % state of charge
- After 90 days (3 months) of storage @ $+20\text{ }^{\circ}\text{C}$ ($+77\text{ }^{\circ}\text{F}$), 1st [Refresh charge](#). An additional 90 days (3 months) of storage can then be added for a total duration of 180 days (6 months)
- After 180 days (6 months) of storage @ $+20\text{ }^{\circ}\text{C}$ ($+77\text{ }^{\circ}\text{F}$), 2nd [Refresh charge](#). An additional 90 days (3 months) of storage can then be added for a total duration of 270 days (9 months)
- At the end of standby storage period of 90 days (3 months) or 180 days (6 months) either:
 - Do a [Refresh charge](#) to continue 1 more standby storage period
 - Or install the serviceable battery into the aircraft without any further maintenance
 - Or place the battery into [Inactive long-term storage](#)
- At the end of standby storage period of 270 days (9 months) or 540 days (18 months) either:
 - Install the serviceable battery into the aircraft without any further maintenance
 - Or continue standby storage:
 - If the temperature is $\leq +30\text{ }^{\circ}\text{C}$ ($+86\text{ }^{\circ}\text{F}$) do [Insulation check](#) + [Residual discharge](#) + [Charge](#) + [Adjust electrolyte level](#) + [Insulation check](#) to continue [Inactive standby storage](#)
 - If the temperature is $> +30\text{ }^{\circ}\text{C}$ ($+86\text{ }^{\circ}\text{F}$) then do a [Regular check](#) to continue standby storage
 - Or place the battery into [Inactive long-term storage](#)
- At the end of standby storage period 810 days (27 months):
 - Install the serviceable battery into the aircraft without any further maintenance
 - Or do a [Regular check](#) and place the battery into [Inactive long-term storage](#)

3. Storage of spare parts

3-1. Spare cell assemblies

Spare cells must be stored in a vertical upright position, filled, and discharged condition (electrolyte levels are not visible in discharged cells). It is not necessary to short circuit the cells. The vent-valves must be installed. The storage conditions are the same as those given in paragraph [Inactive long-term storage](#). No maintenance operation is needed during storage. Before installation in a battery, cells must be visually inspected for damage or leakage and cleaned and maintained as necessary in accordance with [Visual inspection](#).

3-2. Spare O-rings, gaskets, and vent-valves assemblies

3-2-1. O-rings and gaskets

Six (6) years of storage period starts from the date of manufacture unless otherwise specified on the packaging. The O-rings and gaskets should be protected from exposure to the air, light, and high humidity < 85 %. Storage life depends on temperature. It is recommended to store the parts in a cool area < +25 °C (+77 °F). Above +35 °C (+95 °F), storage life is reduced to 5 years. Before use the O-rings or gaskets it must be inspected. In case of visible signs of damage, distortion, or deterioration, the part must be discarded.

3-2-2. Vent-valves with O-rings

Six (6) years of storage period starts from the date of manufacture unless otherwise specified on the packaging. The vent-valves and O-rings should be protected from exposure of air, light and high humidity (< 85 %). Storage life depends on temperature. It is recommended to store the parts in a sealed container (non-PVC) in a cool area < +25 °C (+77 °F). Above +35 °C (+95 °F), storage life is reduced to 5 years. Before use the vent-valves and O-rings it must be inspected. In case of visible signs of damage, deformation, or deterioration, the vent-valve and O-ring must be discarded.

3-2-3. Other spares parts

Other spare parts protected from external contamination (i.e. dirt, dust, dampness, vibration, corrosive atmosphere) and high humidity (> 85 %), may be stored for unlimited periods. Before use, parts must be inspected. Parts showing any visible signs of damage, distortions, or deteriorations must be discarded.

4. Transportation procedure

The battery is normally discharged before packing. If it is necessary to transport a charged battery, make sure that the output terminals are protected against short circuit.

The battery should be packed vertically in its original container. If the original container is not available, the international and/or local packaging regulations applicable to the mode of transport and destination must be followed.

According to the IATA / IMDG dangerous goods regulations, Saft ships all existing nickel-cadmium batteries or cells for aircraft under the classification UN2795 (wet, filled with alkali).