

PRATT & WHITNEY CANADA  
**SERVICE BULLETIN**

P&WC S.B. No. 13540

**BULLETIN INDEX LOCATOR**  
**72-10-00**

TURBOPROP ENGINE  
REDUCTION-GEARBOX PROPELLER-FRONT-HOUSING ASSEMBLY - REPLACEMENT OF  
MODEL APPLICATION

PT6A-60A, PT6A-60AG, PT6A-65AG, PT6A-65AR, PT6A-65B, PT6A-65R

Compliance: CATEGORY 7

Summary: It can be difficult to assemble the engine specification nameplate onto the propeller front Reduction Gearbox (RGB) housing assembly. To ease assembly, replace the propeller front RGB housing assembly with one that has a larger nameplate machine pocket area.

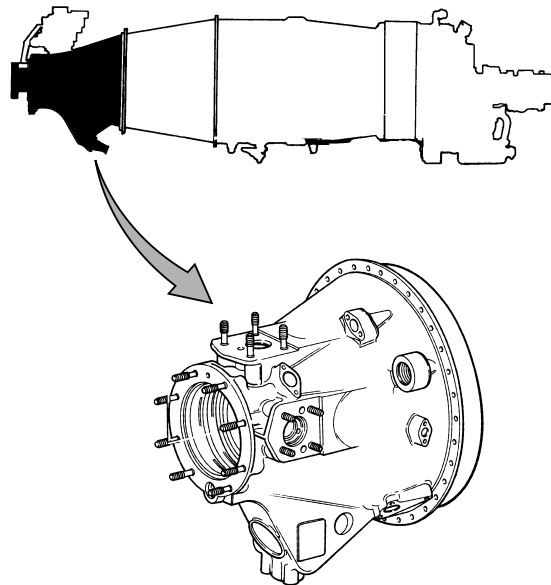

Feb 02/2024

**PT6A-72-13540**  
Cover Sheet

24-Hour Global Service

**CFIRST CENTRE**

Toll free where available (SIL GEN-027)

USA & CANADA..... 1-800-268-8000

International ..... (IAC\*)+8000-268-8000

\* International Access Code

Other ..... 1-450-647-8000

Fax ..... 1-450-647-2888

Web Site ..... [www.pwc.ca](http://www.pwc.ca)

WARNING - PROPRIETARY RIGHTS & EXPORT CONTROLS NOTICE

This bulletin contains proprietary information of Pratt & Whitney Canada Corp. ("P&WC"), which P&WC provides in confidence and solely for the purposes of supporting engine certification and providing applicable information regarding the proper use, maintenance, inspection, repair, servicing and parts application of P&WC products and services, as directed therein. Neither this bulletin nor any information in it may be disclosed to others, or used for any other purpose, including, without limitation, to design, create, develop, reproduce, manufacture or derive any design, part, product, material, process, modification, configuration change or repair, or obtain FAA or other government approval to do so. Possession and use of this bulletin is also subject to the restrictions set out in P&WC's Technical Data Agreement (a copy of which may be obtained by contacting P&WC Technical Publications). The contents of this bulletin may be subject to export control laws. Unauthorized export or re-export of the bulletin, or parts thereof, is prohibited. By accepting and possessing this bulletin, you agree to be bound by the foregoing terms.

If a Government agency or department intends to disclose any information, written notice should be given to:

VP - Legal Services, Pratt & Whitney Canada Corp., 1000 Marie-Victorin (01BE5), Longueuil, Quebec J4G 1A1.

# PRATT & WHITNEY CANADA

# SERVICE BULLETIN

P&WC S.B. No. 13540

## TURBOPROP ENGINE

### REDUCTION-GEARBOX PROPELLER-FRONT-HOUSING ASSEMBLY - REPLACEMENT OF

#### 1. Planning Information

##### A. Effectivity

PT6A-60A (BS613, BS662, BS1024, BS1025, BS1271, BS1272) Engines.

PT6A-60AG (BS919, BS976, BS1048, BS1049, BS1210, BS1212) Engines which are before and include Serial No. PCE-RG0222.

PT6A-65AG (BS708, BS903, BS1101, BS1102) Engines which are before and include Serial No. PCE-PN0629 and PCE-32248 thru PCE-32640 and all engines converted to Engine Model PT6A-65AG (Ref. P&WC engine conversion SB13237, 13238, and 13239).

PT6A-65AR (BS652, BS697) Engines and all engines converted to Engine Model PT6A-65AR (Ref. P&WC engine conversion SB13098).

PT6A-65B (BS595, BS661, BS851, BS1403) Engines which are before and include Serial No. PCE-PP0301 and PCE-32001 thru PCE-32644 and all engines converted to Engine Model PT6A-65B (Ref. P&WC engine conversion SB13064).

PT6A-65R (BS578) Engines which include Serial No. PCE-97001 thru PCE-97201, PCE-97406, PCE-97408 and PCE-97424 and all engines converted to Engine Model PT6A-65R (Ref. P&WC engine conversion SB13078 and 13083).

##### B. Concurrent Requirements

None.

##### C. Reason

###### (1) Problem

It can be difficult to assemble the engine specification nameplate onto the propeller front RGB housing assembly .

###### (2) Cause

The machine pocket area is too small to accommodate nameplate rivets.

###### (3) Solution

Replace the front propeller RGB housing assembly with one that has a larger nameplate machine pocket area.

##### D. Description

Replace the front propeller RGB housing assembly with a new one.

##### E. Compliance

CATEGORY 7 - You can do this service bulletin when the supply of superseded parts is fully used.

P&WC No. CO-0011747

Feb 02/2024

P&WC Proprietary Information. Subject to the restrictions on the back of the locator

© 2024 Pratt & Whitney Canada Corp.  
PRINTED IN CANADA

**PT6A-72-13540**  
Page 1 of 4

PRATT & WHITNEY CANADA  
**SERVICE BULLETIN**

P&WC S.B. No. 13540

TURBOPROP ENGINE  
REDUCTION-GEARBOX PROPELLER-FRONT-HOUSING ASSEMBLY - REPLACEMENT OF

1. Planning Information (Cont'd)

F. Approval

The technical content of this document is approved under the authority of the Transport Canada Civil Aviation (TCCA) Design Approval Organization No: DAO #93-Q-01.

G. Manpower

No more man-hours are necessary to include this service bulletin at overhaul.

H. Weight and Balance

None.

I. Electrical Load Data

Not applicable.

J. Software Accomplishment Summary

Not applicable.

K. References

Illustrated Parts Catalog P/N [3034344](#) (PT6A-60A/60AG)

Illustrated Parts Catalog P/N [3032844](#) (PT6A-65B/65R/65AG/65AR)

Overhaul Manual P/N [3034343](#) (PT6A-60A/60AG)

Overhaul Manual P/N [3032843](#) (PT6A-65B/65R/65AG/65AR)

L. Publications Affected

Illustrated Parts Catalog P/N [3034344](#) (PT6A-60A/60AG)

Illustrated Parts Catalog P/N [3032844](#) (PT6A-65B/65R/65AG/65AR)

M. Interchangeability and Intermixability of Parts

Interchangeability - Refer to Para. 2.C.

Intermixability - Not changed.

2. Material Information

A. Industry Support Information

Not applicable.

# PRATT & WHITNEY CANADA SERVICE BULLETIN

P&WC S.B. No. 13540

## TURBOPROP ENGINE REDUCTION-GEARBOX PROPELLER-FRONT-HOUSING ASSEMBLY - REPLACEMENT OF

### 2. Material Information (Cont'd)

#### B. Material - Price and Availability

You can get the procurable parts listed in Para. 2.C. from any Pratt & Whitney Canada Parts Distribution Center.

The estimated total cost of new parts needed to replace old parts is \$Quote (\$US, 2024).

The new parts are available.

#### C. Material Necessary for Each Engine

The quantity of materials listed in this section is on a per engine basis.

<u>New P/N</u>	<u>Keyword</u>	<u>Old P/N</u>	<u>Qty</u>	<u>Est. Unit List Price (\$US, 2024)</u>	<u>Instructions Dispositions</u>
<b>For Engines PT6A-60A ( BS613, BS662, BS1024, BS1025, BS1271, BS1272):</b>					
<a href="#">3137639-02</a>	Housing Assembly, Propeller Reduction Gearbox, Front	3120081-04	1	Quote	(A)(C)
3137550-01	.Housing, Propeller Reduction Gearbox, Front	3120080-01	1	NP	(B)
<b>For Engines PT6A-60AG(BS919, BS976, BS1048, BS1049, BS1210, BS1212), PT6A-65AG(BS708, BS903, BS1101, BS1102), PT6A-65AR(BS652, BS697), PT6A-65B(BS595, BS661, BS851, BS1403), PT6A-65R(BS578):</b>					
<a href="#">3137639-01</a>	Housing Assembly, Propeller Reduction Gearbox, Front	3120081-03	1	Quote	(A)(C)
3137550-01	.Housing, Propeller Reduction Gearbox, Front	3120080-01	1	NP	(B)

(A) TWO WAY INTERCHANGEABLE (ATA200 Explanation Code 02): The old or the new parts can replace the old or the new part.

(B) NOT INTERCHANGEABLE - (ATA 200 Explanation Code 03): The old part must replace the old part; the new part must replace new part.

(C) Discard the old part if it is unserviceable. Return a serviceable part to stock.

#### D. Reidentified Parts

None.

PRATT & WHITNEY CANADA  
**SERVICE BULLETIN**

P&WC S.B. No. 13540

TURBOPROP ENGINE  
REDUCTION-GEARBOX PROPELLER-FRONT-HOUSING ASSEMBLY - REPLACEMENT OF

2. Material Information (Cont'd)

E. Tooling - Price and Availability

Not Applicable

3. Accomplishment Instructions

- A. Remove the parts in the Old P/N list in Para. 2.C., Material Information, in accordance with the applicable overhaul manual instructions as follows:
- Ref. OHM 72-11-00, REDUCTION GEARBOX - DISASSEMBLY.
- B. Install the parts in the New P/N list in Para. 2.C., Material Information, in accordance with the applicable overhaul manual instructions as follows:
- Ref. OHM 72-11-00, REDUCTION GEARBOX - SUB-ASSEMBLY.
- C. Record the accomplishment of P&WC SB13540 in the applicable engine module log book.