

PRATT & WHITNEY CANADA
SERVICE BULLETIN

P&WC S.B. No. 13536

BULLETIN INDEX LOCATOR
72-40-01

TURBOPROP ENGINE
COMBUSTION-CHAMBER OUTER-LINER ASSEMBLY - MODIFICATION OF
MODEL APPLICATION

PT6A-52, PT6A-60A, PT6A-60AG, PT6A-61, PT6A-62, PT6A-65AG, PT6A-65AR, PT6A-65B,
PT6A-65R

Compliance: CATEGORY 6

Summary: Carbon puffing may occur on certain service engines. To reduce puffing, introduce a modification to the Combustion-Chamber Outer-Liner Assembly which has:

- Trim the wrapper edge to meet minimum clearance,
- add chamfer to segmented louver,
- update coating specification requirements,
- adjust wrapper flange gap,
- adjust double louver height, and
- adjust segmented louver height.

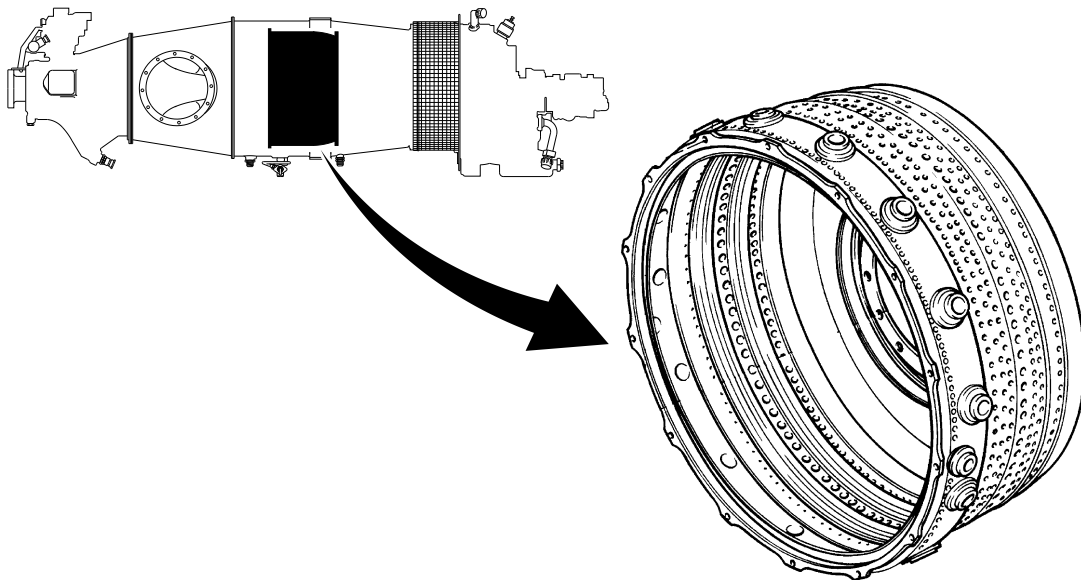

Jan 26/2024

PT6A-72-13536
Cover Sheet

24-Hour Global Service

CFIRST CENTRE

Toll free where available (SIL GEN-027)

USA & CANADA..... 1-800-268-8000

International (IAC*)+8000-268-8000

* International Access Code

Other 1-450-647-8000

Fax 1-450-647-2888

Web Site www.pwc.ca

WARNING - PROPRIETARY RIGHTS & EXPORT CONTROLS NOTICE

This bulletin contains proprietary information of Pratt & Whitney Canada Corp. ("P&WC"), which P&WC provides in confidence and solely for the purposes of supporting engine certification and providing applicable information regarding the proper use, maintenance, inspection, repair, servicing and parts application of P&WC products and services, as directed therein. Neither this bulletin nor any information in it may be disclosed to others, or used for any other purpose, including, without limitation, to design, create, develop, reproduce, manufacture or derive any design, part, product, material, process, modification, configuration change or repair, or obtain FAA or other government approval to do so. Possession and use of this bulletin is also subject to the restrictions set out in P&WC's Technical Data Agreement (a copy of which may be obtained by contacting P&WC Technical Publications). The contents of this bulletin may be subject to export control laws. Unauthorized export or re-export of the bulletin, or parts thereof, is prohibited. By accepting and possessing this bulletin, you agree to be bound by the foregoing terms.

If a Government agency or department intends to disclose any information, written notice should be given to:

VP - Legal Services, Pratt & Whitney Canada Corp., 1000 Marie-Victorin (01BE5), Longueuil, Quebec J4G 1A1.

PRATT & WHITNEY CANADA
SERVICE BULLETIN

P&WC S.B. No. 13536

TURBOPROP ENGINE
COMBUSTION-CHAMBER OUTER-LINER ASSEMBLY - MODIFICATION OF

1. Planning Information

A. Effectivity

PT6A-52 Engines .
PT6A-60A Engines.
PT6A-60AG Engines.
PT6A-61 Engines.
PT6A-62 Engines.
PT6A-65AG Engines.
PT6A-65AR Engines.
PT6A-65B Engines.
PT6A-65R Engines.

B. Concurrent Requirements

None.

C. Reason

(1) Problem

Carbon puffing may occur on various service engines.

(2) Cause

No rework is available to reduce the accumulation and flaking of the carbon build-up within the combustor.

(3) Solution

To reduce puffing, introduce a modification to the Combustion-Chamber Outer-Liner Assembly which has:

- Trim the wrapper edge to meet minimum clearance,
- add chamfer to segmented louver,
- update coating specification requirements,
- adjust wrapper flange gap,
- adjust double louver height, and
- adjust segmented louver height.

D. Description

Modify serviceable Outer Combustion Chamber Liner Assembly.

E. Compliance

CATEGORY 6 - P&WC recommends to do this service bulletin when the subassembly (i.e. module, accessories, components, or build groups) is disassembled and access is available to the necessary part. Do all spare subassemblies.

P&WC No. CO-0014872, CO-0015258

Jan 26/2024

P&WC Proprietary Information. Subject to the restrictions on the back of the locator

© 2024 Pratt & Whitney Canada Corp.
PRINTED IN CANADA

PT6A-72-13536
Page 1 of 13

PRATT & WHITNEY CANADA
SERVICE BULLETIN

P&WC S.B. No. 13536

TURBOPROP ENGINE
COMBUSTION-CHAMBER OUTER-LINER ASSEMBLY - MODIFICATION OF

1. Planning Information (Cont'd)

F. Approval

The technical content of this document is approved under the authority of the Transport Canada Civil Aviation (TCCA) Design Approval Organization No: DAO #93-Q-01.

G. Manpower

Estimate of 15 man-hours required to modify the old part to the new configuration.

H. Weight and Balance

None.

I. Electrical Load Data

Not applicable.

J. Software Accomplishment Summary

Not applicable.

K. References

Illustrated Parts Catalog P/N [3072864](#) (PT6A-52)

Illustrated Parts Catalog P/N [3034344](#) (PT6A-60A/60AG/61)

Illustrated Parts Catalog P/N [3034544](#) (PT6A-62)

Illustrated Parts Catalog P/N [3032844](#) (PT6A-65B/65R/65AG/65AR)

Maintenance Manual P/N [3072862](#) (PT6A-52)

Maintenance Manual P/N [3034342](#) (PT6A-60A/60AG/61)

Maintenance Manual P/N [3034542](#) (PT6A-62)

Maintenance Manual P/N [3032842](#) (PT6A-65B/65R/65AG/65AR)

Overhaul Manual P/N [3072863](#) (PT6A-52)

Overhaul Manual P/N [3034343](#) (PT6A-60A/60AG/61)

Overhaul Manual P/N [3034543](#) (PT6A-62)

PRATT & WHITNEY CANADA SERVICE BULLETIN

P&WC S.B. No. 13536

TURBOPROP ENGINE COMBUSTION-CHAMBER OUTER-LINER ASSEMBLY - MODIFICATION OF

1. Planning Information (Cont'd)

Overhaul Manual P/N [3032843](#) (PT6A-65B/65R/65AG/65AR)

L. Publications Affected

Illustrated Parts Catalog P/N [3072864](#) (PT6A-52)

Illustrated Parts Catalog P/N [3034344](#) (PT6A-60A/60AG/61)

Illustrated Parts Catalog P/N [3034544](#) (PT6A-62)

Illustrated Parts Catalog P/N [3032844](#) (PT6A-65B/65R/65AG/65AR)

M. Interchangeability and Intermixability of Parts

Interchangeability - Refer to Para. 2.C.

Intermixability - Not changed.

2. Material Information

A. Industry Support Information

Not applicable.

B. Material - Price and Availability

Not applicable.

C. Material Necessary for Each Engine

The quantity of materials listed in this section is on a per engine basis.

<u>New P/N</u>	<u>Keyword</u>	<u>Old P/N</u>	<u>Qty</u>	<u>Est. Unit List Price (\$US, 2023)</u>	<u>Instructions Dispositions</u>
For the PT6A-52 Engines:					
01R3070268-01	Combustion Chamber, Outer Liner Assembly	3070268-01	RWK		(A)(B)(C)
01R3123553-01	Combustion Chamber, Outer Liner Assembly	3123553-01	RWK		(A)(B)(C)

For the PT6A-60A Engines:

Jan 26/2024

P&WC Proprietary Information. Subject to the restrictions on the back of the locator

PT6A-72-13536
Page 3 of 13

PRATT & WHITNEY CANADA SERVICE BULLETIN

P&WC S.B. No. 13536

TURBOPROP ENGINE COMBUSTION-CHAMBER OUTER-LINER ASSEMBLY - MODIFICATION OF

2. Material Information (Cont'd)

<u>New P/N</u>	<u>Keyword</u>	<u>Old P/N</u>	<u>Qty</u>	<u>Est. Unit List Price (\$US, 2023)</u>	<u>Instructions Dispositions</u>
01R3055434-01	Combustion Chamber, Outer Liner Assembly	3055434-01	RWK		(A)(B)(C)
01R3055663-01	Combustion Chamber, Outer Liner Assembly	3055663-01	RWK		(A)(B)(C)
01R3070035-01	Combustion Chamber, Outer Liner Assembly	3070035-01	RWK		(A)(B)(C)
01R3070268-01	Combustion Chamber, Outer Liner Assembly	3070268-01	RWK		(A)(B)(C)
02R3115834-01	Combustion Chamber, Outer Liner Assembly	3115834-01	RWK		(A)(B)(C)
01R3123553-01	Combustion Chamber, Outer Liner Assembly	3123553-01	RWK		(A)(B)(C)
For the PT6A-60AG Engines:					
01R3055434-01	Combustion Chamber, Outer Liner Assembly	3055434-01	RWK		(A)(B)(C)
01R3055663-01	Combustion Chamber, Outer Liner Assembly	3055663-01	RWK		(A)(B)(C)
01R3070268-01	Combustion Chamber, Outer Liner Assembly	3070268-01	RWK		(A)(B)(C)
01R3123553-01	Combustion Chamber, Outer Liner Assembly	3123553-01	RWK		(A)(B)(C)
For the PT6A-61 Engines:					
01R3055434-01	Combustion Chamber, Outer Liner Assembly	3055434-01	RWK		(A)(B)(C)
01R3055663-01	Combustion Chamber, Outer Liner Assembly	3055663-01	RWK		(A)(B)(C)
01R3070268-01	Combustion Chamber, Outer Liner Assembly	3070268-01	RWK		(A)(B)(C)
02R3115834-01	Combustion Chamber, Outer Liner Assembly	3115834-01	RWK		(A)(B)(C)

Jan 26/2024

P&WC Proprietary Information. Subject to the restrictions on the back of the locator

PT6A-72-13536
Page 4 of 13

PRATT & WHITNEY CANADA SERVICE BULLETIN

P&WC S.B. No. 13536

TURBOPROP ENGINE COMBUSTION-CHAMBER OUTER-LINER ASSEMBLY - MODIFICATION OF

2. Material Information (Cont'd)

<u>New P/N</u>	<u>Keyword</u>	<u>Old P/N</u>	<u>Qty</u>	<u>Est. Unit List Price (\$US, 2023)</u>	<u>Instructions Dispositions</u>
01R3123553-01	Combustion Chamber, Outer Liner Assembly	3123553-01	RWK		(A)(B)(C)
For the PT6A-62 Engines:					
01R3055434-01	Combustion Chamber, Outer Liner Assembly	3055434-01	RWK		(A)(B)(C)
01R3055663-01	Combustion Chamber, Outer Liner Assembly	3055663-01	RWK		(A)(B)(C)
01R3070035-01	Combustion Chamber, Outer Liner Assembly	3070035-01	RWK		(A)(B)(C)
01R3070268-01	Combustion Chamber, Outer Liner Assembly	3070268-01	RWK		(A)(B)(C)
02R3115834-01	Combustion Chamber, Outer Liner Assembly	3115834-01	RWK		(A)(B)(C)
01R3123553-01	Combustion Chamber, Outer Liner Assembly	3123553-01	RWK		(A)(B)(C)
For the PT6A-65AG, PT6A-65AR, PT6A-65B, PT6A-65R Engines:					
01R3055434-01	Combustion Chamber, Outer Liner Assembly	3055434-01	RWK		(A)(B)(C)
01R3055663-01	Combustion Chamber, Outer Liner Assembly	3055663-01	RWK		(A)(B)(C)
01R3079486-01	Combustion Chamber, Outer Liner Assembly	3079486-01	RWK		(A)(B)(C)
02R3115834-01	Combustion Chamber, Outer Liner Assembly	3115834-01	RWK		(A)(B)(C)

(A) TWO WAY INTERCHANGEABLE (ATA200 Explanation Code 02): The old or the new parts can replace the old or the new part.

(B) To get the new part it is necessary to make a modification to the old part.

PRATT & WHITNEY CANADA SERVICE BULLETIN

P&WC S.B. No. 13536

TURBOPROP ENGINE COMBUSTION-CHAMBER OUTER-LINER ASSEMBLY - MODIFICATION OF

2. Material Information (Cont'd)

<u>New P/N</u>	<u>Keyword</u>	<u>Old P/N</u>	<u>Qty</u>	<u>Est. Unit List Price (\$US, 2023)</u>	<u>Instructions Dispositions</u>
----------------	----------------	----------------	------------	--	--------------------------------------

(C) Return the old part(s) for rework to:

Atech Turbine Components Inc
1st Mark Street
Auburn, MA 01510
United States

Or

Turbine Weld Industries LLC
402 Substation Road
Venice, FL 34285
United States

Or

Unified Turbines Inc
28 Catamount Drive
Milton, VT 05468
United States

D. Reidentified Parts

<u>OLD P/N</u>	<u>NEW P/N</u>
3055434-01	01R3055434-01
3055435-01	01R3055435-01
3055663-01	01R3055663-01
3070035-01	01R3070035-01
3070268-01	01R3070268-01
3079486-01	01R3079486-01
3115834-01	02R3115834-01
3123553-01	01R3123553-01

E. Tooling - Price and Availability

Not Applicable

PRATT & WHITNEY CANADA
SERVICE BULLETIN

P&WC S.B. No. 13536

TURBOPROP ENGINE
COMBUSTION-CHAMBER OUTER-LINER ASSEMBLY - MODIFICATION OF

3. Accomplishment Instructions

- A. Remove the parts in the Old P/N list in Para. 2.C., Material Information, in accordance with the maintenance or overhaul manual instructions as follows:

Ref. MM 72-40-01 PT6A-52/60A/60AG/61/62/65AG/AR/B/R.

Ref. OHM 72-40-01 PT6A-52/60A/60AG/61/62/65AG/AR/B/R.

- B. Return Old serviceable part(s) for modification in accordance with Para. 2.C.

- C. Install the parts in the New P/N list in Para. 2.C., Material Information, in accordance with the maintenance or overhaul manual instructions as follows:

Ref. MM 72-40-01 PT6A-52/60A/60AG/61/62/65AG/AR/B/R.

Ref. OHM 72-40-01 PT6A-52/60A/60AG/61/62/65AG/AR/B/R.

- D. Write the accomplishment of P&WC S.B. No. 13536 in the applicable engine module log book.

4. Appendix

Refer to figure 1 for the PT6A-52 Part progression

Refer to figure 2 for the PT6A-60A-60AG-61 Part progression

Refer to figure 3 for the PT6A-62 Part progression

Refer to figure 4 for the PT6A-65AR-65AG-65B-65R Part progression

PRATT & WHITNEY CANADA
SERVICE BULLETIN

P&WC S.B. No. 13536

TURBOPROP ENGINE
COMBUSTION-CHAMBER OUTER-LINER ASSEMBLY - MODIFICATION OF

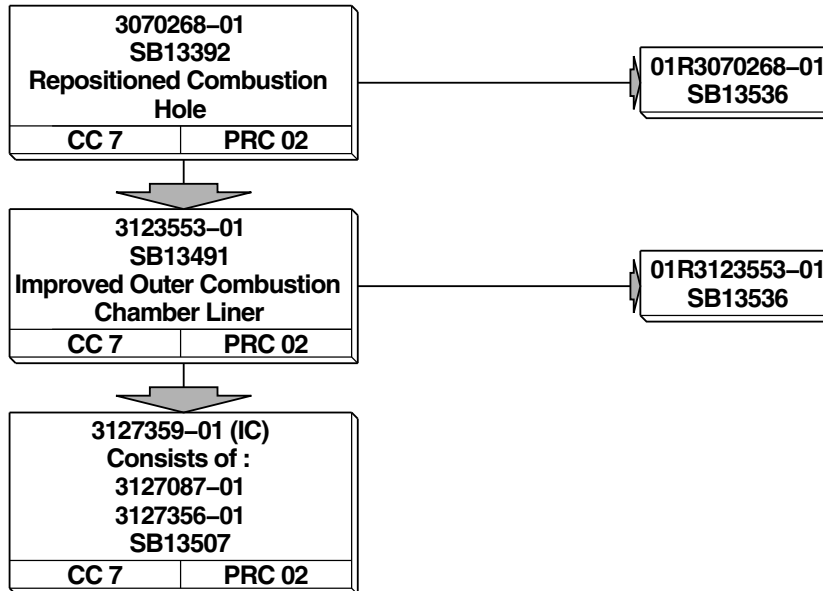

ICN-00198-G000134724-001-01

PT6A-52 Parts Progression
Figure 1

Jan 26/2024

P&WC Proprietary Information. Subject to the restrictions on the back of the locator

PT6A-72-13536
Page 8 of 13

PRATT & WHITNEY CANADA SERVICE BULLETIN

P&WC S.B. No. 13536

TURBOPROP ENGINE COMBUSTION-CHAMBER OUTER-LINER ASSEMBLY - MODIFICATION OF

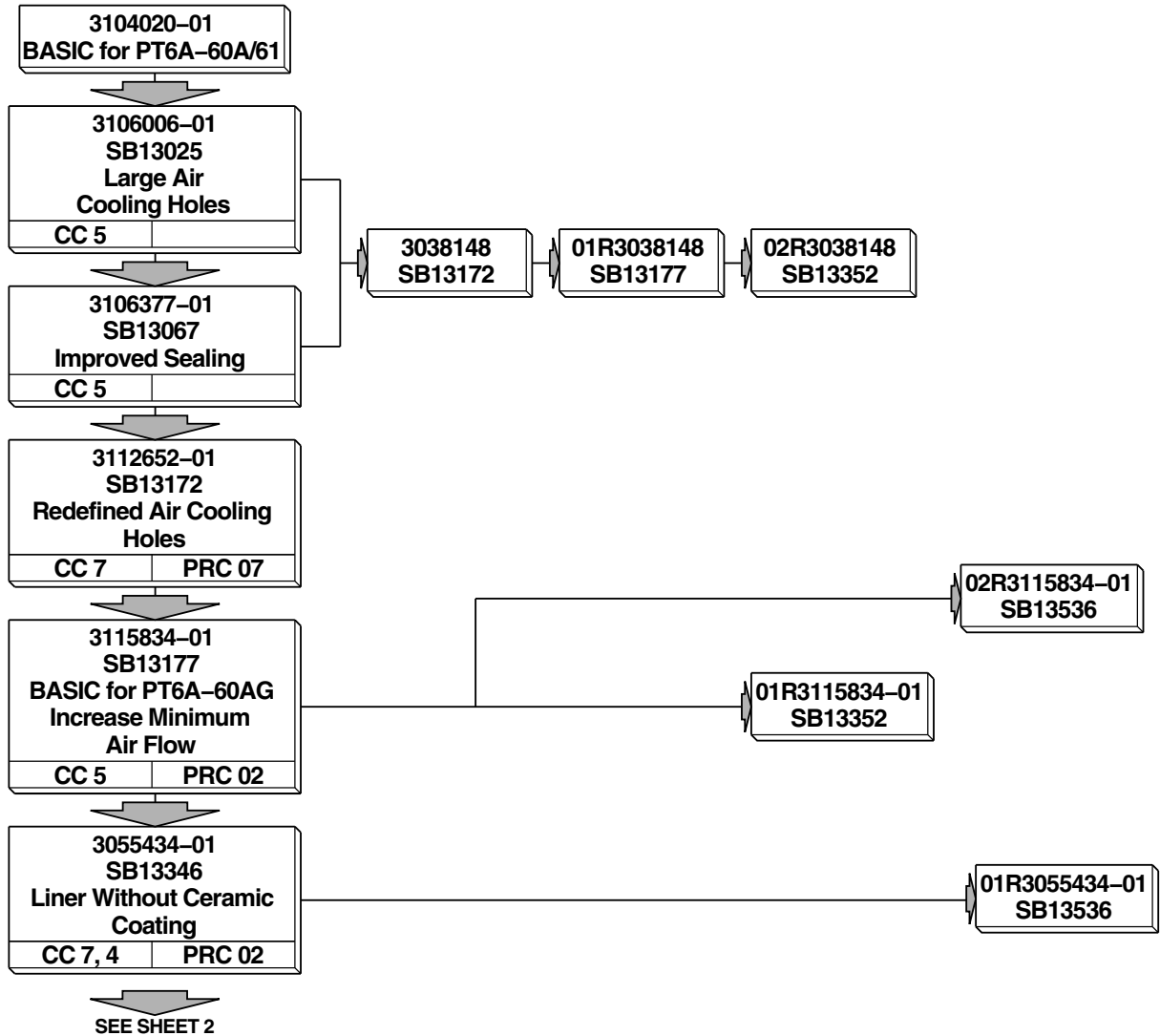

ICN-00198-G000134725-001-01

PT6A-60A-60AG-61 Parts Progression
Figure 2 (Sheet 1 of 2)

Jan 26/2024

P&WC Proprietary Information. Subject to the restrictions on the back of the locator

PT6A-72-13536
Page 9 of 13

PRATT & WHITNEY CANADA SERVICE BULLETIN

P&WC S.B. No. 13536

TURBOPROP ENGINE COMBUSTION-CHAMBER OUTER-LINER ASSEMBLY - MODIFICATION OF

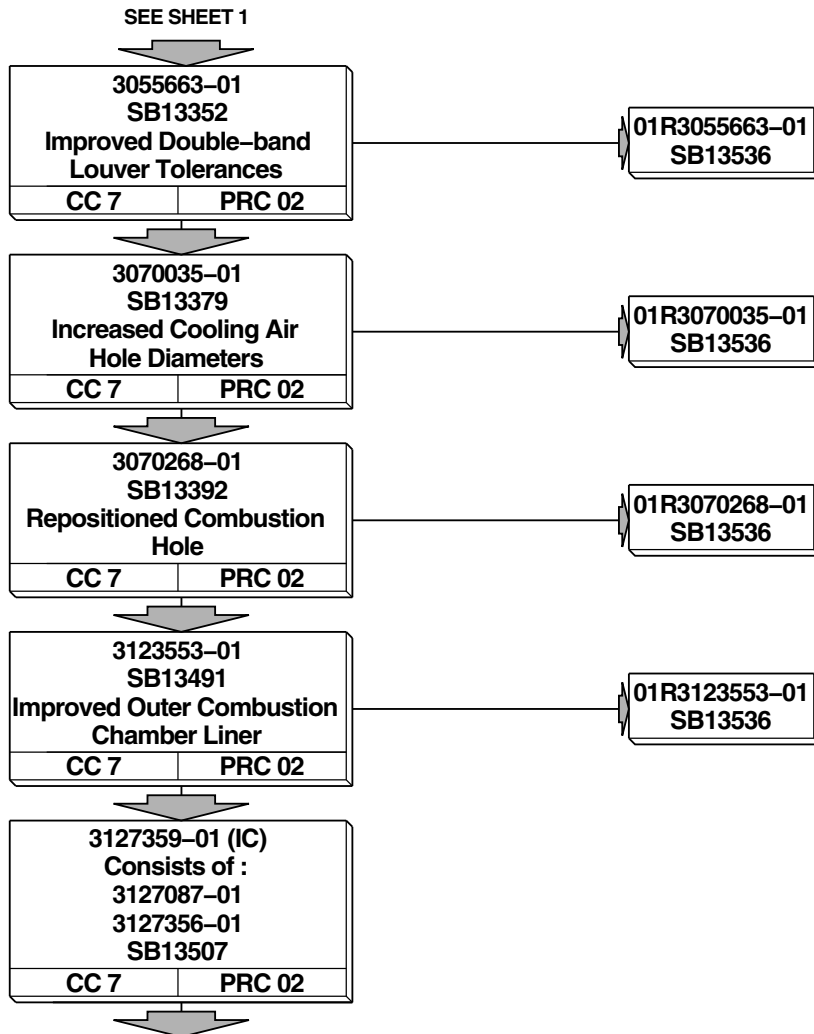

ICN-00198-G000134726-001-01

PT6A-60A-60AG-61 Parts Progression
Figure 2 (Sheet 2)

Jan 26/2024

P&WC Proprietary Information. Subject to the restrictions on the back of the locator

PT6A-72-13536
Page 10 of 13

PRATT & WHITNEY CANADA SERVICE BULLETIN

P&WC S.B. No. 13536

TURBOPROP ENGINE COMBUSTION-CHAMBER OUTER-LINER ASSEMBLY - MODIFICATION OF

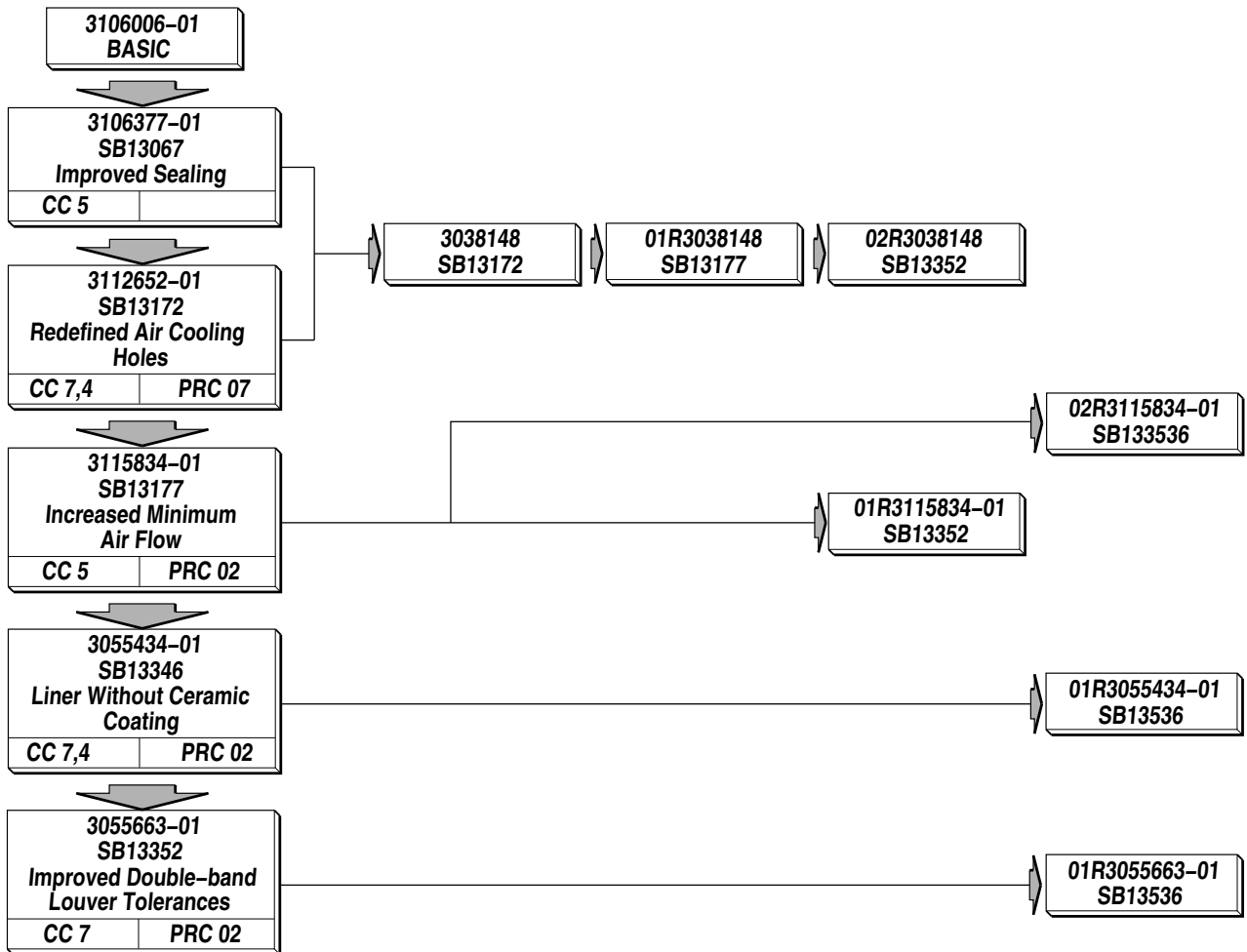

REFER SHEET 2

ICN-00198-G000134727-001-01

PT6A-62 Parts Progression
Figure 3 (Sheet 1 of 2)

Jan 26/2024

P&WC Proprietary Information. Subject to the restrictions on the back of the locator

PT6A-72-13536
Page 11 of 13

PRATT & WHITNEY CANADA
SERVICE BULLETIN

P&WC S.B. No. 13536

TURBOPROP ENGINE
COMBUSTION-CHAMBER OUTER-LINER ASSEMBLY - MODIFICATION OF

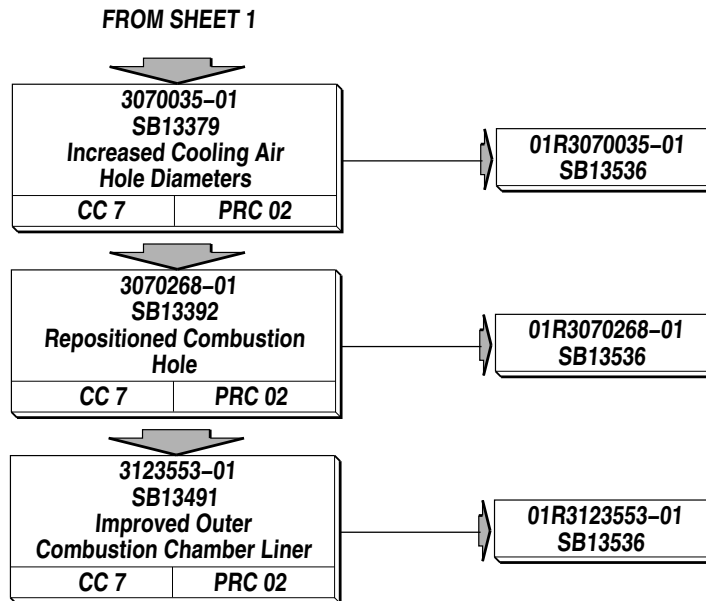

ICN-00198-G000134730-001-01

PT6A-62 Parts Progression
Figure 3 (Sheet 2)

Jan 26/2024

P&WC Proprietary Information. Subject to the restrictions on the back of the locator

PT6A-72-13536
Page 12 of 13

PRATT & WHITNEY CANADA SERVICE BULLETIN

P&WC S.B. No. 13536

TURBOPROP ENGINE COMBUSTION-CHAMBER OUTER-LINER ASSEMBLY - MODIFICATION OF

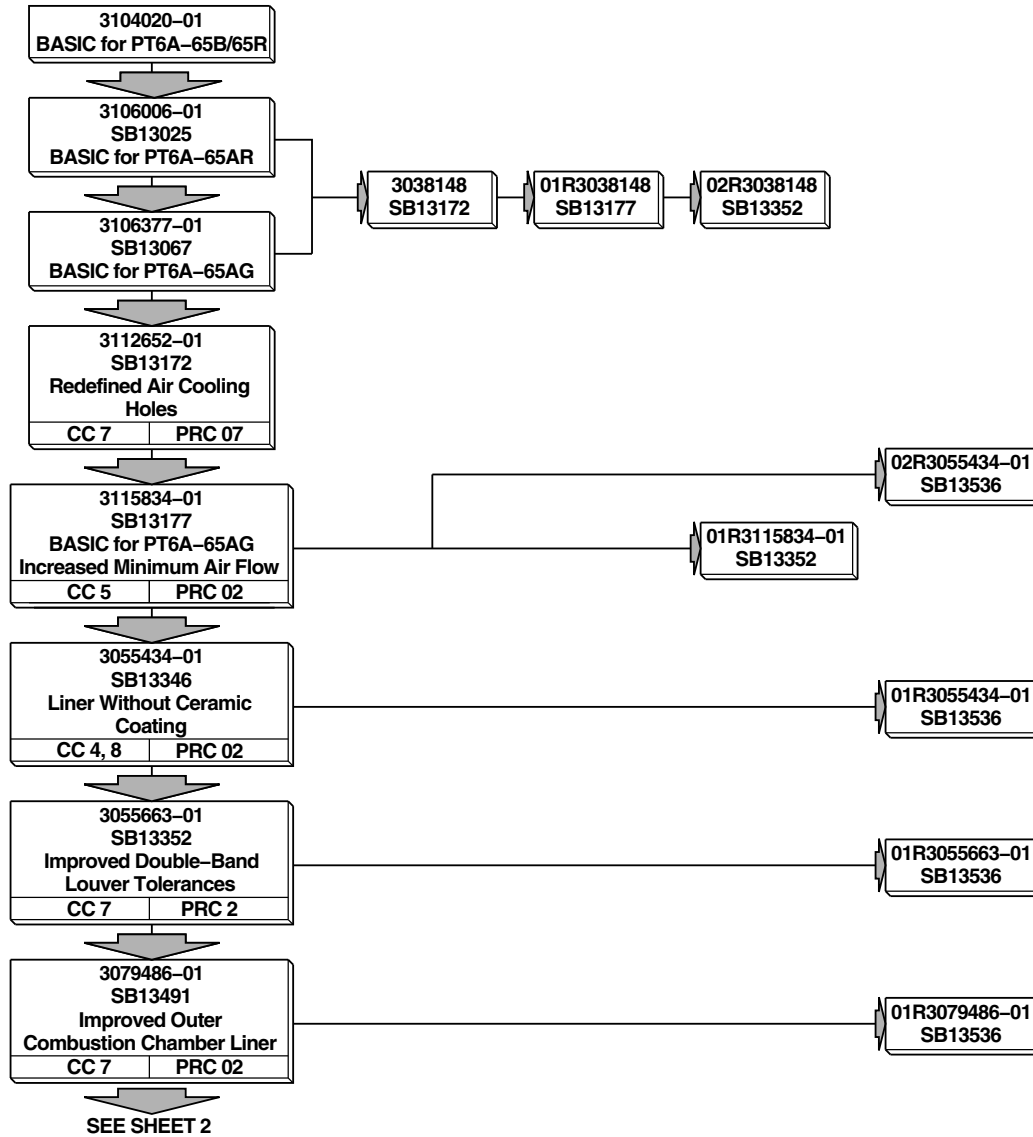

ICN-00198-G000134607-001-01

PT6A-65AR-65AG-65B-65R Parts Progression
Figure 4

Jan 26/2024

P&WC Proprietary Information. Subject to the restrictions on the back of the locator

PT6A-72-13536
Page 13 of 13