

PRATT & WHITNEY CANADA
SERVICE BULLETIN

P&WC S.B. No. 13523

BULLETIN INDEX LOCATOR
74-10-00

TURBOPROP ENGINE
IGNITION EXCITER - REPLACEMENT OF

MODEL APPLICATION

PT6A-52, PT6A-60A, PT6A-61, PT6A-65AG, PT6A-65AR, PT6A-65B, PT6A-65R

Compliance: CATEGORY 7

Summary: The ignition exciter spider switch is no longer available due to obsolescence. Replace the ignition exciter with one that has an available spider switch.

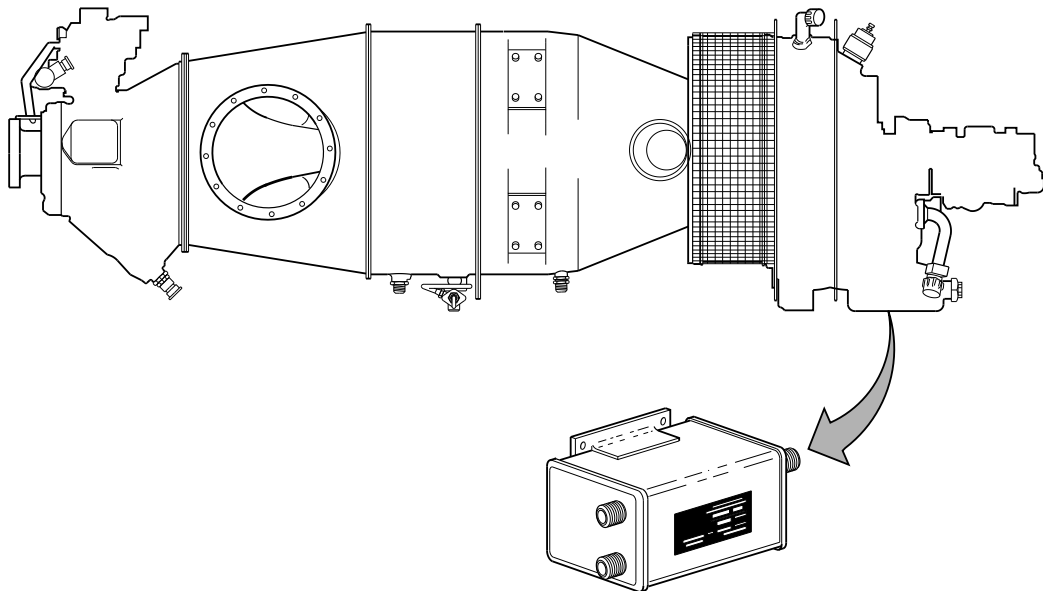

Feb 24/2021

PT6A-74-13523
Cover Sheet

24-Hour Global Service CFIRST CENTRE Toll free where available (SIL GEN-027)	USA & CANADA..... 1-800-268-8000 International (IAC*)+8000-268-8000 * International Access Code	Other 1-450-647-8000 Fax 1-450-647-2888 Web Site www.pwc.ca
---	---	---

WARNING - PROPRIETARY RIGHTS & EXPORT CONTROLS NOTICE

This bulletin contains proprietary information of Pratt & Whitney Canada Corp. ("P&WC"), which P&WC provides in confidence and solely for the purposes of supporting engine certification and providing applicable information regarding the proper use, maintenance, inspection, repair, servicing and parts application of P&WC products and services, as directed therein. Neither this bulletin nor any information in it may be disclosed to others, or used for any other purpose, including, without limitation, to design, create, develop, reproduce, manufacture or derive any design, part, product, material, process, modification, configuration change or repair, or obtain FAA or other government approval to do so. Possession and use of this bulletin is also subject to the restrictions set out in P&WC's Technical Data Agreement (a copy of which may be obtained by contacting P&WC Technical Publications). The contents of this bulletin may be subject to export control laws. Unauthorized export or re-export of the bulletin, or parts thereof, is prohibited. By accepting and possessing this bulletin, you agree to be bound by the foregoing terms.

If a Government agency or department intends to disclose any information, written notice should be given to:

VP - Legal Services, Pratt & Whitney Canada Corp., 1000 Marie-Victorin (01BE5), Longueuil, Quebec J4G 1A1.

PRATT & WHITNEY CANADA

SERVICE BULLETIN

P&WC S.B. No. 13523

TURBOPROP ENGINE IGNITION EXCITER - REPLACEMENT OF

1. Planning Information

A. Effectivity

PT6A-52 BS1228, BS1269, BS1270, BS1358, BS1435 Engines which are before and include Serial No. PCE-RX1137.

PT6A-60A BS613, BS662, BS1024, BS1025, BS1271, BS1272 Engines which are before and include Serial No. PCE-PK2666 and PCE-95006 thru PCE-95828.

PT6A-61 BS1236, BS1275 Engines which are before and include Serial No. PCE-HA0305 and Serial No. which include PCE-99001 thru PCE-99142.

PT6A-65AG BS1101, BS1102 Engines and all engines converted to Engine Model PT6A-65AG (Ref. P&WC engine conversion SB13237, 13238, and 13239).

PT6A-65AR BS652, BS697, BS738 Engines and all engines converted to Engine Model PT6A-65AR (Ref. P&WC engine conversion SB13098).

PT6A-65B BS680, BS690, BS709, BS851, BS1305, BS1403 Engines, and all engines converted to Engine Model PT6A-65B (Ref. P&WC engine conversion SB13064).

PT6A-65R Engines which include Serial No. PCE-97001 thru PCE-97201, PCE-97406, PCE-97408 and PCE-97424 and all engines converted to Engine Model PT6A-65R (Ref. P&WC engine conversion SB13078 and 13083).

B. Concurrent Requirements

None.

C. Reason

(1) Problem

The ignition exciter spider switch is no longer available.

(2) Cause

The ignition exciter spider switch has been obsoleted.

(3) Solution

Replace the ignition exciter with one that has an available spider switch.

D. Description

Replace the ignition exciter with a new one.

E. Compliance

CATEGORY 7 - You can do this service bulletin when the supply of superseded parts is fully used.

P&WC No. CO-0010422

Feb 24/2021

P&WC Proprietary Information. Subject to the restrictions on the back of the locator

© 2021 Pratt & Whitney Canada Corp.
PRINTED IN CANADA

PT6A-74-13523
Page 1 of 8

PRATT & WHITNEY CANADA
SERVICE BULLETIN

P&WC S.B. No. 13523

TURBOPROP ENGINE
IGNITION EXCITER - REPLACEMENT OF

1. Planning Information (Cont'd)

F. Approval

D.O.T./D.A.A. approved.

G. Manpower

Once you have access to the part, an estimate of 1.0 man-hours is required to include this service bulletin at repair.

No more man-hours are necessary to include this service bulletin at overhaul.

H. Weight and Balance

None.

I. Electrical Load Data

Not applicable.

J. Software Accomplishment Summary

Not applicable.

K. References

Illustrated Parts Catalog P/N [3072864](#) (PT6A-52)

Illustrated Parts Catalog P/N [3034344](#) (PT6A-60A/60AG/61)

Illustrated Parts Catalog P/N [3032844](#) (PT6A-65B/65R/65AG/65AR)

Maintenance Manual P/N [3072862](#) (PT6A-52)

Maintenance Manual P/N [3034342](#) (PT6A-60A/60AG/61)

Maintenance Manual P/N [3032842](#) (PT6A-65B/65R/65AG/65AR)

Overhaul Manual P/N [3072863](#) (PT6A-52)

Overhaul Manual P/N [3034343](#) (PT6A-60A/60AG/61)

Overhaul Manual P/N [3032843](#) (PT6A-65B/65R/65AG/65AR)

Champion SBCH92106-74-003

PRATT & WHITNEY CANADA SERVICE BULLETIN

P&WC S.B. No. 13523

TURBOPROP ENGINE IGNITION EXCITER - REPLACEMENT OF

1. Planning Information (Cont'd)

L. Publications Affected

Illustrated Parts Catalog P/N [3072864](#) (PT6A-52)

Illustrated Parts Catalog P/N [3034344](#) (PT6A-60A/60AG/61)

Illustrated Parts Catalog P/N [3032844](#) (PT6A-65B/65R/65AG/65AR)

Champion CMM 74-11-05

M. Interchangeability and Intermixability of Parts

Interchangeability - Refer to Para. 2.C.

Intermixability - Not changed.

2. Material Information

A. Industry Support Information

Not applicable.

B. Material - Price and Availability

You can get the procurable parts listed in Para. 2.C. from any Pratt & Whitney Canada Parts Distribution Center.

The estimated total cost of new parts needed to replace old parts is \$Quote (US, 2021).

The new parts are available now.

C. Material Necessary for Each Engine

The quantity of materials listed in this section is on a per engine basis.

<u>New P/N</u>	<u>Keyword</u>	<u>Old P/N</u>	<u>Qty</u>	<u>Est. Unit List Price (\$US, 2021)</u>	<u>Instructions Dispositions</u>
	Ignition Exciter (0AFL4) P&WC P/N 3043937-08	CH92106-3	1		(A)(B)
CH92106-5	Ignition Exciter (0AFL4) P&WC P/N 3043937-10		1	Quote	(A)

PRATT & WHITNEY CANADA
SERVICE BULLETIN

P&WC S.B. No. 13523

TURBOPROP ENGINE
IGNITION EXCITER - REPLACEMENT OF

2. Material Information (Cont'd)

<u>New P/N</u>	<u>Keyword</u>	<u>Old P/N</u>	<u>Qty</u>	<u>Est. Unit List Price (\$US, 2021)</u>	<u>Instructions Dispositions</u>
----------------	----------------	----------------	------------	--	--------------------------------------

(A) TWO WAY INTERCHANGEABLE (ATA200 Explanation Code 02): The old or the new parts can replace the old or the new part.

(B) Discard the part if it is unserviceable. Return a serviceable part to stock.

D. Reidentified Parts

None.

E. Tooling - Price and Availability

Not Applicable

3. Accomplishment Instructions

A. Remove the parts in the Old P/N list in Para. 2.C., Material Information, in accordance with the maintenance or overhaul manual instructions as follows:

Ref. MM 74-10-00.

Ref. OHM 74-10-00.

B. Install the parts in the New P/N list in Para. 2.C., Material Information, in accordance with the maintenance or overhaul manual instructions as follows:

Ref. MM 74-10-00.

Ref. OHM 74-10-00.

C. Write the accomplishment of P&WC SB13523 in the engine module log book.

4. Appendix

Refer to Figure 1 for the PT6A-52 ignition exciter part progression.

Refer to Figure 2 for the PT6A-60A ignition exciter part progression.

Refer to Figure 3 for the PT6A-61 ignition exciter part progression.

Refer to Figure 4 for the PT6A-65AR ignition exciter part progression. **PT6A-52 PT6A-60A
PT6A-61 PT6A-65AR**

PRATT & WHITNEY CANADA SERVICE BULLETIN

P&WC S.B. No. 13523

TURBOPROP ENGINE IGNITION EXCITER - REPLACEMENT OF

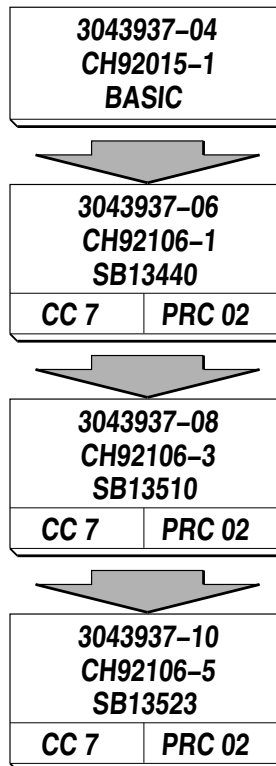

ICN-00198-G000042912-001-01

IGNITION EXCITER - Parts Progression
Figure 1

Feb 24/2021

P&WC Proprietary Information. Subject to the restrictions on the back of the locator

PT6A-74-13523
Page 5 of 8

PRATT & WHITNEY CANADA SERVICE BULLETIN

P&WC S.B. No. 13523

TURBOPROP ENGINE IGNITION EXCITER - REPLACEMENT OF

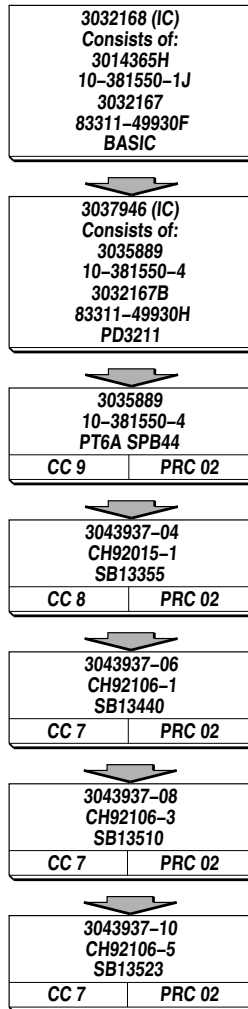

ICN-00198-G000042913-001-01

IGNITION EXCITER - Parts Progression
Figure 2

Feb 24/2021

P&WC Proprietary Information. Subject to the restrictions on the back of the locator

PT6A-74-13523
Page 6 of 8

PRATT & WHITNEY CANADA SERVICE BULLETIN

P&WC S.B. No. 13523

TURBOPROP ENGINE IGNITION EXCITER - REPLACEMENT OF

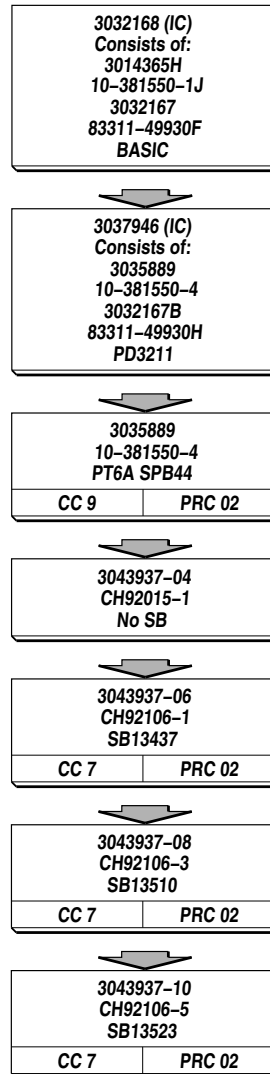

ICN-00198-G000042914-001-01

IGNITION EXCITER - Parts Progression
Figure 3

Feb 24/2021

P&WC Proprietary Information. Subject to the restrictions on the back of the locator

PT6A-74-13523
Page 7 of 8

PRATT & WHITNEY CANADA SERVICE BULLETIN

P&WC S.B. No. 13523

TURBOPROP ENGINE IGNITION EXCITER - REPLACEMENT OF

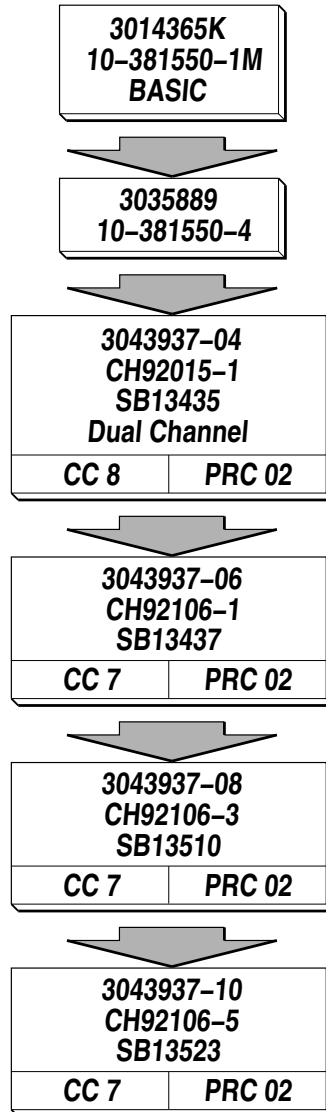

ICN-00198-G000042916-001-01

IGNITION EXCITER - Parts Progression
Figure 4

Feb 24/2021

P&WC Proprietary Information. Subject to the restrictions on the back of the locator

PT6A-74-13523
Page 8 of 8