

AIRBUS

EC 120 B



Chapter 05 MASTER SERVICING MANUAL (MSM)

Issue date : 2014.05.15
Revision 007 : 2021.07.05

Airbus Helicopters
Direction Technique Support
Aéroport International Marseille Provence 13725 Marignane Cedex FRANCE
Contact: contact.msm.ah@airbus.com

IMPORTANT NOTE

The practical value of this manual depends entirely upon it being updated correctly by the operator.

The successive revisions should be recorded on the relevant page of the manual.

LOEDU

1 Update

Refer to the "Update" Document Unit

2 "Type" Column Code

- N-New, to be inserted
- R-Revised, to be replaced
- D-To be removed from the manual
- (No code) Unchanged with respect to the previous issue

D.U.	Type	Date	D.U.	Type	Date
TITLE	N	2021.07.05	05-10-00	R	2021.07.05
LOEDU	N	2021.07.05	05-11-00	-	2016.04.28
TABLE OF CONTENTS	N	2021.07.05	05-20-00	-	2014.05.15
HIGHLIGHTS OF THE REVISION	N	2021.07.05	05-20-02	-	2018.03.26
TECHNICAL PUBLICATIONS	-	2019.03.11	05-21-00	-	2020.03.09
GLOSSARY	-	2014.05.15	05-21-01	-	2015.04.09
STRUCTURE OF THE MSM	-	2019.03.11	05-21-02	R	2021.07.05
UPDATE OF THE MSM	-	2015.04.09	05-22-00	R	2021.07.05
BREAKDOWN OF THE MSM	R	2021.07.05	05-22-02	R	2021.07.05
USE OF THE MSM	R	2021.07.05	05-23-00	-	2019.03.11
OPTIONAL	-	2020.03.09	05-23-02	-	2018.03.26
SB INCORPORATED	R	2021.07.05	05-24-02	-	2014.05.15
			05-25-00	-	2019.03.11
			05-26-00	R	2021.07.05

End of the Document Unit

TABLE OF CONTENTS

TITLE

HIGHLIGHTS OF THE REVISION

- 1 GENERAL
- 2 OUTLINE OF THE REVISION
- 3 DETAILED DESCRIPTION
 - 3.1 BREAKDOWN OF THE MSM
 - 3.2 USE OF THE MSM
 - 3.3 SB INCORPORATED
 - 3.4 Section 05.10.00
 - 3.5 Section 05.21.02
 - 3.6 Section 05.22.00
 - 3.7 Section 05.22.02
 - 3.8 Section 05.26.00

TECHNICAL PUBLICATIONS

- 1 THE DOCUMENTATION
- 2 OPERATING DOCUMENTS
- 3 MAINTENANCE DOCUMENTS
- 4 IDENTIFICATION DOCUMENTS
- 5 SPECIAL DOCUMENTS
- 6 VENDOR'S DOCUMENTS

GLOSSARY

STRUCTURE OF THE MSM

- 1 GENERAL STRUCTURE OF THE MSM
- 2 BREAKDOWN OF THE MSM
 - 2.1 Identification of the DUs
 - 2.2 Task codes
 - 2.3 List Of Effective Document Units (LOEDU)
- 3 CLASSIFICATION OF INFORMATION

UPDATE OF THE MSM

- 1 REVISION OF THE MSM
- 2 UPDATE OF THE MSM
 - 2.1 Update procedure

TITLE

- 2.2 Identification of the modifications
- 3 CUSTOMER COMPLEMENT (CC): ISSUED ON A GREEN BACKGROUND
- 4 EFFECTIVITY

BREAKDOWN OF THE MSM

- 1 PURPOSE OF THE MSM
- 2 CHANGES TO THE MSM
- 3 HELICOPTER MAINTENANCE
- 4 TYPES OF MAINTENANCE
- 5 DEFINITION OF THE MAINTENANCE MODES
 - 5.1 Hard time maintenance
 - 5.2 On-Condition maintenance
 - 5.3 Condition monitoring maintenance
- 6 EFFECTIVITY - RESPONSIBILITY
- 7 MAINTENANCE INTERVAL
 - 7.1 Daily checks
 - 7.2 Scheduled operations
- 8 MAINTENANCE RELATED TO EQUIPMENT MANUFACTURER DOCUMENTATION

USE OF THE MSM

- 1 ADAPTATION OF THE MSM
- 2 INFORMATION FEEDBACK FROM THE OPERATOR TO THE MANUFACTURER
- 3 IN-SERVICE MONITORING
 - 3.1 Airframe monitoring
 - 3.2 Monitoring of components
- 4 COMPONENT PART NUMBERS
 - 4.1 Definition
 - 4.2 Part number with a different letter
 - 4.3 Applicability of the limits
 - 4.4 Changes to Part Numbers
- 5 LIMITS
 - 5.1 Flight Hours
 - 5.2 Calendar time
 - 5.2.1 Airframe initial aging date
 - 5.2.2 Initial aging date for components

TITLE

- 5.3 Cycles
- 5.4 Provisional limitations
- 5.5 Periodic and Perform Once limits
- 5.6 Performance interval
- 5.7 Specific and severe atmospheric operating conditions
- 5.8 Maximum limit value
 - 5.8.1 Definition of the margin
 - 5.8.2 Application of the margin
 - 5.8.3 Specification of the margin
 - 5.8.4 Example of how the margin is used

6 HELICOPTER-SERIALIZATION OF THE COMPONENTS

- 6.1 Principle
- 6.2 Identification marking

7 TRANSFER OF A COMPONENT (PART OR ASSEMBLY) FROM ONE HELICOPTER TO ANOTHER HELICOPTER**8 RECORDING****9 SCHEDULED MAINTENANCE CHECKS – MAINTENANCE OPERATIONS**

- 9.1 Particular inspection cases
- 9.2 Rules of procedure

10 STORAGE HELICOPTER

- 10.1 Helicopter in flight conditions - Parking
- 10.2 Storage duration « T0 » definition
- 10.3 Renewal procedure
- 10.4 Storage inspection tolerance
- 10.5 Sheltered/Unsheltered Area

11 MAINTENANCE CODES (MC)**12 CONTENT OF A TASK****OPTIONAL**

- 1 COMPATIBILITY / INCOMPATIBILITY
- 2 TABLE OF APPROVED OPTIONAL INSTALLATIONS

SB INCORPORATED

End of the Document Unit

HIGHLIGHTS OF THE REVISION

1 GENERAL

- Check that the content of the sections is in accordance with the List Of Effective Document Units (LOEDU).
- Return the acknowledgment card.

2 OUTLINE OF THE REVISION

The revision is codified as follows:

- Revision 007: 2021.07.05

3 DETAILED DESCRIPTION

3.1 BREAKDOWN OF THE MSM

- § 2 "CHANGES TO THE MSM"
Updated

3.2 USE OF THE MSM

- § 10 "STORAGE HELICOPTER"
Added
- § 12 "CONTENT OF A TASK"
Updated

3.3 SB INCORPORATED

- SB 05-017
SKURKA starter generators: cheking the level of wear on the brushes and commutator
Deleted
- SB 53A017
Rear fuselage - Corrosion on the tail boom
Added

3.4 Section 05.10.00

24-36 STARTER/GENERATOR

- 24/36/01/000/000/050
Starter generator
Description modified
Limit modified

900 FH // 60 M

- 24/36/01/000/000/500 1200 FH // 60 M
Starter generator
Description modified
Limit modified
- 24/36/02/000/000/150 1200 FH // 60 M
Starter generator
Description modified
Limit modified

3.5 Section 05.21.02

53-50 AFT FUSELAGE

- 53/50/00/000/000/310 12 M
Tail boom
Documentation modified

3.6 Section 05.22.00

52-30 LOADING DOORS

- 52/30/00/000/000/000 500 FH // 24 M
Door lock
New task integrated

71-41 ENGINE SUPPORT BRACKET

- 71/41/00/000/000/200 500 FH // 24 M
Engine support bracket components
Documentation modified

3.7 Section 05.22.02

53-50 AFT FUSELAGE

- 53/50/00/000/000/300 24 M
Tail boom
Documentation modified

3.8 Section 05.26.00

24-36 STARTER/GENERATOR

- 24/36/01/000/000/550 300 FH
Starter generator
Task modified

End of the Document Unit

TECHNICAL PUBLICATIONS

1 THE DOCUMENTATION

The technical documentation intended for operators is mainly broken down into five groups:

2 OPERATING DOCUMENTS

- **The Master Servicing Manual (MSM)** is intended particularly for those responsible for helicopter maintenance. It specifies the maintenance limits.
- **The Airworthiness Limitations Section (ALS)** is intended for those responsible for helicopter maintenance. It defines the mandatory limits and checks.
- **The FLight Manual (FLM)** is intended for flight crews. It specifies the limits, standard and emergency procedures and helicopter performance data.
- **The Master Minimum Equipment List (MMEL)** specifies the minimum list of equipment necessary for flight.

3 MAINTENANCE DOCUMENTS

- **The Aircraft Maintenance Manual (AMM)** specifies the maintenance procedures necessary to service the helicopter.
- **The System Description Section (SDS)** comprises part 1 of the AMM and explains how the systems operate.
- **The Wiring Diagram Manual (WDM)** combines all the helicopter wiring diagrams.

4 IDENTIFICATION DOCUMENTS

- **The Illustrated Parts Catalog (IPC)** contains all the spare parts necessary to ensure continued serviceability of the helicopter.

5 SPECIAL DOCUMENTS

- **Service Bulletins (SB), Alert Service Bulletins (ASB) and Emergency Alert Service Bulletins (EASB)** are intended to inform the operators of instructions introduced following new events (incidents, modifications, etc.). These documents supplement the helicopter documents and are incorporated in the latter by updates if necessary.
- **Information Notices (IN)** and **Safety Information Notices (SIN)** are documents issued for information. Their purpose is to remind operators of existing maintenance procedures, or to inform them of changes validated by Airbus and undergoing introduction.

6 VENDOR'S DOCUMENTS

- This documentation comprises the following vendor's manuals: **Vendor's Service Bulletins (SBV), Engine Maintenance Manual (EMM)** and **Component Maintenance Manual (CMM)**.

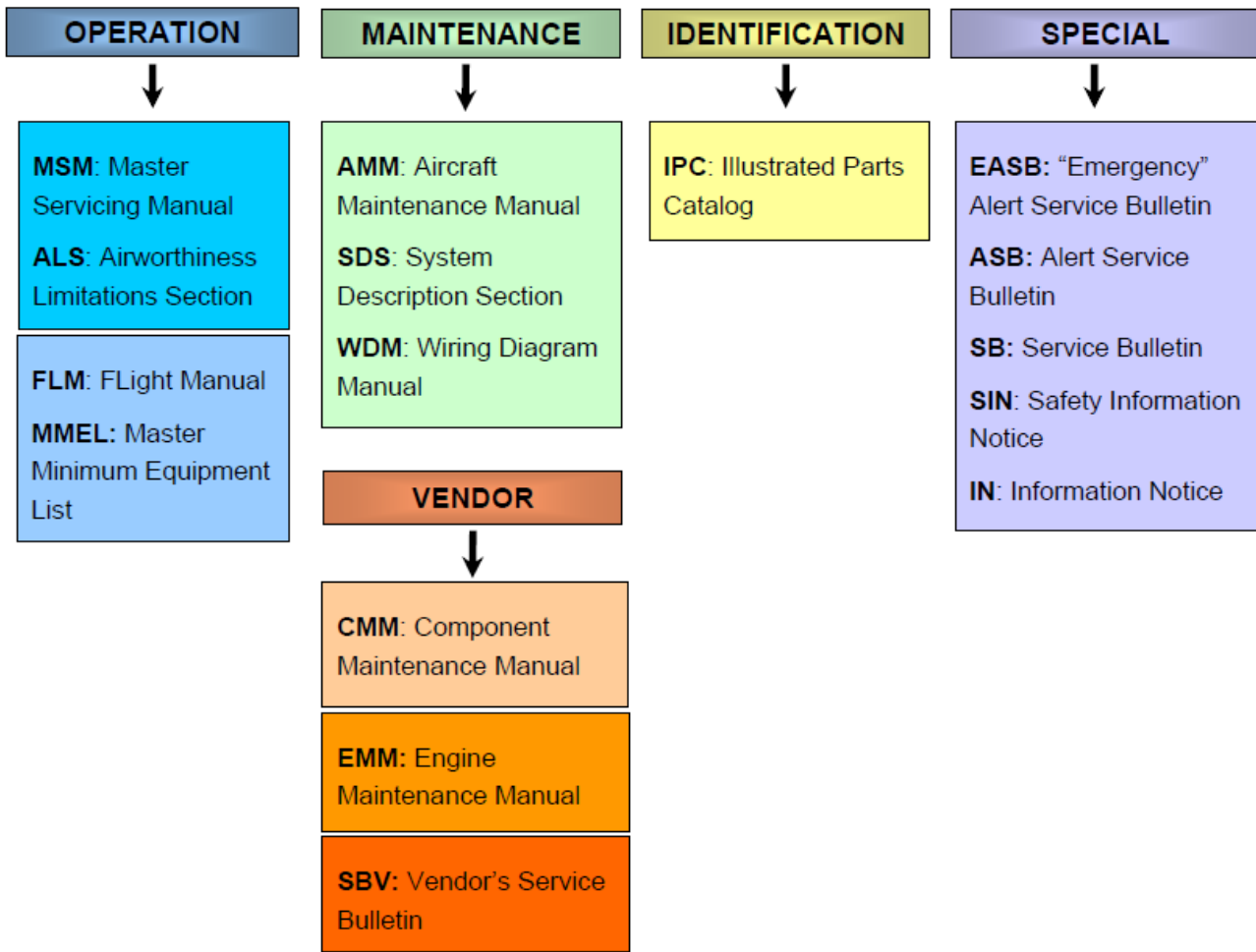

End of the Document Unit

GLOSSARY

(-):	Not indicated
&:	And
//:	Or
§:	Paragraph
ALF:	Check After the Last Flight of the day
ALS:	Airworthiness Limitations Section
AMM:	Aircraft Maintenance Manual
ASB:	Alert Service Bulletin
BFF:	Check Before the First Flight of the day
CLN:	CLeaNing
CM:	Condition Monitoring
CMM:	Component Maintenance Manual
D:	Day
DI:	Detailed Inspection
DRN:	DRaiNing
DS:	DiScard
DU:	Document Unit
EASA:	European Aviation Safety Agency
ED:	Expiry Date
EMM:	Engine Maintenance Manual
FH:	Flight Hour
FLM:	FLight Manual
FM:	Log card
FT:	Functional Test
GR:	Ground Run
GVI:	General Visual check (Visual inspection with access equipment and standard tools)
HC:	Hoist Cycle
HT:	Hard Time maintenance
JAA:	Joint Aviation Authorities
LOEDU:	List Of Effective Document Units
LC:	Landing Cycle
LUB:	LUBrication
M:	Month
MC:	Maintenance Code
MGB:	Main Gear Box
MMEL:	Master Minimum Equipment List
MP/N:	Manufacturer Part Number
MRH:	Main Rotor Hub
MSM:	Master Servicing Manual
NPT:	New Proof Test
OC:	On Condition

OPC:	OPerating Cycles
OPH:	OPerating Hours
OTL:	Operating Time Limit
P:	P-check
P/N:	Part Number
PO:	Perform Once
RC:	Roping Cycle
RIG:	RiggInG
RS:	ReStoration
RTQ:	Readjustment of the TorQue loading
SB:	Service Bulletin
SC:	Sling Cycle
SDI:	Special Detailed Inspection
SLL:	Service Life Limit
S/N:	Serial Number
SVC:	SerViCing
TBO:	Time Between Overhauls
TCK:	Torque Check
TGB:	Tail Gear Box
TRH:	Tail Rotor Hub
TSI:	Time Since Installation
TSM:	Time Since Manufacture
VC:	Visual Check
WC:	Work Card
WGH:	WeiGHing

End of the Document Unit

STRUCTURE OF THE MSM

1 GENERAL STRUCTURE OF THE MSM

The Master Servicing Manual (MSM) is broken down into two parts.

The first part comprises general information which explains how the MSM operates and how it must be used.

The second part which defines the scheduled maintenance comprises the following sections:

- 05-10-00, which lists the components subject to a Time Between Overhauls (TBO), as well as the corresponding limits.
- 05-11-00, which lists the components subject to an Operating Time Limit (OTL), as well as the corresponding limits.
- 05-20-00 (daily check), 05-20-02 (periodic interval 15 FH//7 D).
- 05-21-00 (periodic interval 100 FH//12 M), 05-21-01 (periodic interval 100 FH) and 05-21-02 (periodic interval 12 M).
- 05-22-00 (periodic interval 500 FH//24 M), 05-22-01 (periodic interval 500 FH) and 05-22-02 (periodic interval 24 M).
- 05-23-00 (periodic interval 1500 FH//72 M) and 05-23-02 (periodic interval 72 M).
- 05-24-02 (periodic interval 144 M).
- 05-25-00 (specific periodic interval).
- 05-26-00 (perform once time limits to be complied with a limited number of times).

These sections specify the maintenance operations to be performed on the helicopter, periodically or a limited number of times, regardless of the operating conditions.

2 BREAKDOWN OF THE MSM

The various parts of the MSM are presented in the form of Document Units (DUs).

2.1 Identification of the DUs

Each DU is unique and is identified by the following:

- The title of the manual at the top right hand side of the page,
- The effectivity (helicopter type and version) marked at the bottom left hand side of the page,
- The date code of the DU at the bottom left hand side of the page below the effectivity (format: year.month.day),
- The number or title of the DU at the bottom right hand side of the page,
- The page number at the bottom right hand side of the page.

The end of each Document Unit is identified by "End of the Document Unit" on the last page.

2.2 Task codes

The DUs in sections 05-10-00, 05-11-00, 05-20-0x, 05-21-0x, 05-22-0x, 05-23-0x, 05-24-02, 05-25-00, 05-26-00 comprise maintenance tasks. These tasks are identified by a unique code specific to Airbus, comprising a group of 15 characters.

Example:

24/36/01/000/000/050	Starter generator		
	160SG140Q1 160SG140Q1XL	(7050A4243037) (7050A4243050)	900 FH 100 FH
	SKURKA.		

The first four digits (**24/36/01/000/000/050**) correspond to the ATA chapter/section breakdown.

The fifth and sixth digit (24/36/**01**/000/000/050) are used to subdivide an ATA chapter/section comprising several subjects into individual subjects.

The seventh to fifteenth digit (24/36/01/**000/000/050**) are used to identify the tasks per ATA chapter/section/subject.

2.3 List Of Effective Document Units (LOEDU)

The LOEDU specifies the following information, for each DU, in a table:

- The Document Unit (DU): this column specifies the number of the DU or the title of the DU (example: 05-21-00).
- The type: this column is coded with the letter "R" if the DU is revised, "D" if the DU is destroyed, "N" if the DU is new, or has no code for DUs which are unchanged.
- The date: this column indicates the DU date code.

3 CLASSIFICATION OF INFORMATION

The DUs in sections 05-10-00, 05-11-00, 05-20-0x, 05-21-0x, 05-22-0x, 05-23-0x, 05-24-02, 05-25-00 and 05-26-00 are classed in increasing order according to ATA 100 numbering.

End of the Document Unit

UPDATE OF THE MSM

1 REVISION OF THE MSM

The MSM is revised approximately once a year.

The MSM cover page bears the issue date code (first issue), the current revision number taken in chronological order followed by the revision date code (example: Issue date: 2010.01.30, Revision 002: 2010.07.30, the last applicable revision is revision 002 with a date code of 2010.07.30).

The date code marked on the new or revised DUs corresponds to the revision date code marked on the cover page.

2 UPDATE OF THE MSM

2.1 Update procedure

The user is responsible for updating his documentation each time he receives a revision or a new issue from the manufacturer. The MSM is updated using the new LOEDU which specifies which DU must be inserted (new DU), replaced (revised DU) or removed (deleted DU). A deleted DU is issued with the wording "DU TO BE REMOVED FROM THE MANUAL" in the revision concerned.

Once the MSM has been updated, the date code of each DU indicated at the bottom left hand side of each page must correspond with the LOEDU.

The beginning of the MSM includes a "HIGHLIGHTS OF THE REVISION" page which explicitly summarizes the modifications made to each revision or new issue.

NOTE

After updating, the "RECORD OF REVISIONS" page at the beginning of the MSM must be completed (date, name and signature).

2.2 Identification of the modifications

Modifications are identified by a revision mark in the form of a vertical line in the right hand margin of the page.

Revision marks are not used in the following DUs:

- LOEDU,
- Table of contents,
- Highlights of the revision.

3 CUSTOMER COMPLEMENT (CC): ISSUED ON A GREEN BACKGROUND

The Customer Complement adds Document Units to the Basic Manual, which partially or totally modify the information it contains.

THE INFORMATION GIVEN ON THESE DOCUMENT UNITS TAKES PRECEDENCE OVER THE INFORMATION GIVEN IN THE BASIC MANUAL.

This information is specific to the customer and helicopter(s) identified at the bottom of the pages.

The Customer Complement Document Units can be revised by reissue of the complete typesetting for a given customer. No Basic Manual Revision Document Unit is cancelled by a Customer Complement Revision.

A supplement to the "LIST OF EFFECTIVE DOCUMENT UNITS" lists the Customer Complement Document Units. The Basic Manual Revisions (on a white background) are completely separate from the Customer Complement Revisions (issued on a green background).

4 EFFECTIVITY

The operator must check the effectivity of the MSM used (correctly updated) for the helicopter concerned.

The effectivity (helicopter type and version) is indicated on the cover page and is repeated at the bottom of each page comprising the MSM DUs.

End of the Document Unit

BREAKDOWN OF THE MSM

1 PURPOSE OF THE MSM

The Master Servicing Manual (MSM) is drawn up by the helicopter manufacturer and specifies all the maintenance operations to be performed by the operator.

It specifies all the maintenance operations and limits recommended by the helicopter manufacturer, to ensure continued airworthiness, operational availability and performance of the helicopter (*), in all its varied operating missions.

For the maintenance operations and limits assigned to the engine components, refer to the engine manufacturer's documentation.

(*) Helicopter (type/version) defined by Airbus.

2 CHANGES TO THE MSM

The MSM is modified by the manufacturer according to changes in helicopter definition and operational feedback.

The technical content of this document is approved under authority DOA ref. EASA.21J.700.

3 HELICOPTER MAINTENANCE

Helicopter maintenance consists in applying all the operations specified in the various sections of the MSM.

It must be performed by personnel with the required qualifications.

Maintenance includes the monitoring, servicing and reconditioning of a helicopter's components, as specified in the various manuals, taking into account the information that the manufacturer makes known to the operator via Alert Service Bulletins, Service Bulletins, Safety Information Notice, Information Notice etc.

4 TYPES OF MAINTENANCE

Preventive Maintenance:

Preventive maintenance consists of all the scheduled, and generally repetitive, operations to check and maintain a given operating condition.

Corrective Maintenance:

Corrective maintenance consists of all the operations that are performed after detection of a fault or failure in order to re-establish the initial operating condition.

Remedial Maintenance:

Remedial maintenance consists of all the operations initiated to permanently correct a failure, and to partially or wholly eliminate the preventive and corrective maintenance of this failure.

The preventive maintenance is given in the Master Servicing Manual.

5 DEFINITION OF THE MAINTENANCE MODES

There are three main maintenance modes:

- Hard time maintenance.
- On-condition maintenance.
- Condition monitoring maintenance.

The modes (defined below) differ mainly in how the replacement (or repair) of a component with a serviceable component is initiated. With the first two modes, the aim is to replace (or repair) the component before it fails, whereas in the third mode, to replace it after it fails.

5.1 Hard time maintenance

A component subject to hard time maintenance must be removed at the latest when it reaches its limit.

There are three types of hard time maintenance limits:

- **Service Life Limit (SLL)**

The SLL is an airworthiness limitation.

Components which are essential for operating safety which are subject to undetectable damage due to the loads they withstand, are covered by a Service Life Limit. These components must be removed from service when the specified limit is reached.

These limits are listed in chapter 04.

- **Operating Time Limit (OTL)**

Components whose possible failure would have lesser consequences on flight safety than components with a Service Life Limit, are assigned an Operating Time Limit. These components must be removed from service when the specified limit is reached.

- **Time Between Overhauls (TBO)**

A TBO is assigned to a complete assembly. The interval corresponds to the operating time permitted before an overhaul is performed in a specialized workshop. The overhaul allows the assembly to be returned to service for a new period.

The interval corresponds to a period during which any increase in damage cannot be detected by routine maintenance (example: internal corrosion, fretting leading to the loosening of bolted assemblies, etc.).

NOTE

The time limits assigned to components guarantee flight safety with regard to the flight load fatigue alteration of components with no external deterioration. These time limits are not a commercial guarantee because a component may be removed due to wear, fretting corrosion or scoring, etc., before the expiry of the time limits.

The only warranty applicable to the helicopter and any component is the warranty included in the Sales Contract for the helicopter and the components.

5.2 On-Condition maintenance

A component subject to On-Condition maintenance must be inspected periodically to confirm:

- that there is no damage,
- or that the damage found is within the removal or maintenance criteria specified in the documentation.

In both cases, the component is kept in service until the next inspection. The component must be removed from service when it reaches the criterion for removal, or made serviceable again as per the instructions given in the documentation.

The visual inspection is aimed at the overall external appearance of the component (no distortion, failure, cracks, scratches, signs of heating or wear, etc.), which would modify its original condition.

STANDING INSTRUCTIONS RELATIVE TO CONDITION: Surface deterioration and deterioration to protection and paint on all helicopter components must be examined and treated without delay in accordance with the applicable instructions (criteria, then reworking).

5.3 Condition monitoring maintenance

A component is subject to condition monitoring only after its failure (which has no impact on flight safety) has been detected. Such failures are detected during maintenance or in service. These components are not listed in the MSM.

6 EFFECTIVITY - RESPONSIBILITY

The limits assigned to the component part numbers listed in the MSM are applicable to material:

- acquired directly from Airbus or through the Airbus subsidiaries or distribution network,
- purchased from the equipment vendors listed in our spare part catalogs, either directly or through their own distribution network.

In all cases, the manufacturing source is specified in the "airworthiness document" (JAA Form One or equivalent).

Airbus will not carry out repairs on components which were procured other than through the Airbus distribution network.

WARNING

IT IS PROHIBITED TO REUSE PARTS, EQUIPMENT OR ASSEMBLIES, COMING FROM A HELICOPTER WHICH HAS INVOLVED IN AN ACCIDENT, WITHOUT FORMAL TECHNICAL APPROVAL FROM THE AIRBUS CUSTOMER TECHNICAL SUPPORT DEPARTMENT.

REMINDER: THE AIR ACCIDENT INVESTIGATION BOARD OF THE COUNTRY CONCERNED IS RESPONSIBLE FOR CLASSING AN EVENT AS AN ACCIDENT.

7 MAINTENANCE INTERVAL

7.1 Daily checks

The purpose of the daily checks is to ensure the serviceability of the aircraft for the flights.

The daily checks are broken down as follows:

- **15 FH // 7 D inspection**

The 15 FH // 7 D inspection is intended to check the operational availability of the helicopter between 2 checks.

This check must be performed at the latest at 15 flight hours without exceeding 7 days.

There are three possible cases in which this check is to be triggered:

- The helicopter flies 15 hours within less than 7 days. The 15 FH // 7 D inspection must be performed at the latest at 15 flight hours.
- The helicopter flies less than 15 flight hours within 7 days. The 15 FH // 7 D inspection must be performed at the latest at 7 days.
- The helicopter is grounded during 7 days or more. The 15 FH // 7 D inspection must be performed before resuming flights.

- **Inspection of optional installations**

In addition to the 15 FH // 7 D inspections related to optional installations, daily checks (before the first flight of the day (BFF), and after the last flight of the day (ALF)) must be performed in accordance with the procedures specified in the Aircraft Maintenance Manual (AMM).

The purpose of these checks is to ensure the operational availability of the helicopter for flights and they must be performed by:

- A maintenance-qualified personnel.
- or
- A crew member who has received an appropriate training by the operator's maintenance department, if authorized by local authorities.



If in doubt or if a fault is detected, the crew member must call on the head of maintenance in order to perform the maintenance operations.

In compliance with the criteria specified in Maintenance Manual, the mechanic will decide:

- Either to authorize flights while monitoring the defective component (in such a case the mechanic must inform the pilot of the criteria which must be observed to continue the flights of the day).
- Or to carry out the remedial actions before resuming flights.

- **Acceptance of an aircraft by the pilot and/or when a modification is embodied on the aircraft:**

The mechanic or the person in charge of the maintenance engineering must inform the pilot on a routine basis of:

- Any modification to the definition that has been embodied on the aircraft.
- Any possible change in the limit interval of the component modified.

- **Cold weather and very cold weather routine check**

According to the lowest temperatures reached, a supplementary program is defined in the AMM (AMM 05-30-00, 6-3).

7.2 Scheduled operations

- Operations at 100 FH or 12 M intervals focused on checking the condition of components with short inspection interval.
- Operations at 500 FH or 24 M intervals, based on:
 - condition monitoring of the components and systems by functional tests,
 - inspection of the condition of the components which have a direct impact on the airworthiness of the helicopter.

It is aimed at checking the overall condition of the helicopter through detailed visual checks of the systems and equipment (no distortion, failure, cracks, scratches, corrosion, signs of heating, wear, impacts, etc.).

It is supplemented:

- every 3rd time with operations with 1500 FH or 72 M intervals,
- by a specific operation.

NOTE

At each inspection, make sure:

- that no additional action has recently been specified by the manufacturer by way of an Alert Service Bulletin or Service Bulletin, etc.,

- that no interval or limit has been modified by way of an Alert Service Bulletin or Service Bulletin, etc.,

- that no interval or limit specified by the MSM has been reached.

The limits (TBO, OTL, SLL) specified in MSM section 05-10-00, 05-11-00 and ALS section 04-10-00 must also be taken into account where necessary in order to replace components which must be replaced before the next inspection.

8 MAINTENANCE RELATED TO EQUIPMENT MANUFACTURER DOCUMENTATION

For the maintenance of equipment approved under STC (Supplemental Type Certificate), refer to the applicable supplier documentation provided upon delivery of this equipment.

End of the Document Unit

USE OF THE MSM

1 ADAPTATION OF THE MSM

The Master Servicing Manual (MSM) presents the limits for the maintenance operations recommended by the manufacturer.

It can be used as is or it can be adapted by each operator according to his operational needs on the condition he has the approval of his aviation authorities and that he complies with the interval for each maintenance operation.

2 INFORMATION FEEDBACK FROM THE OPERATOR TO THE MANUFACTURER

The operator must inform his local aviation authorities and the aircraft manufacturer of any significant failure or malfunction discovered in operation or in maintenance, particularly when the component in question is maintained by condition monitoring.

This feedback can be essential for maintaining airworthiness (refer to chapter 04 – DU: USE OF THE ALS - § "Occurrence reporting").

This is also applicable in case of an accident.

3 IN-SERVICE MONITORING

3.1 Airframe monitoring

The in-service monitoring of the airframe must be recorded in the helicopter logbook.

3.2 Monitoring of components

All the components listed in section 05-10-00 and 05-11-00 of the MSM are to be monitored in service, unless "not to be monitored in service" is specifically mentioned in the task.

The in-service monitoring of components consists in recording the date of installation, the number of flight hours and/or the calendar time and/or the cycles logged on the equipment log card (**FM**).

If the component does not have a log card (component monitored via the log card of its higher assembly or component without a serial number, etc.), before installation, the operator must organize his documentation in order to comply with the inspection intervals and limits relating to this component (refer to Standard Practices Manual Work Card 20.08.05.101).

These records must be kept if the component is transferred from one helicopter to another.

All the documentation must be organized to enable recording of all the parameters used to comply with the limits.

4 COMPONENT PART NUMBERS

4.1 Definition

- **Manufacturer Part Number (MP/N)**: This is the identification number of the component marked on the identification plate or directly on the component.
- **Airbus Part Number (P/N)**: This is the Airbus part number which is associated with the manufacturer's part number (MP/N) for components which are not manufactured by Airbus.

The part numbers of the components (part or assembly) which are given in the MSM are the manufacturer's part numbers (MP/N).

In the case of components which are not manufactured by Airbus, the MP/N is followed by the associated P/N (in brackets).

Example:

24/36/02/000/000/150			
Starter generator	524-061	(704A46101021)	2400 FH
AUXILEC.			240 FH

In some cases the P/N is not specified, in this case it is replaced by a hyphen.

4.2 Part number with a different letter

In some cases, the MP/N can have a different letter (example: MP/N C623D1002104), used for spares, to indicate the installation of an optional component or a specific configuration.

These MP/Ns with a different letter generally do not appear in the MSM.

The limit applicable to a MP/N with a different letter is identical to that of the MP/N displayed in the MSM.

Example: the limit given for assembly MP/N C623A1002104 is valid for assembly MP/N C623A1002104 and assembly MP/N C623D1002104.

4.3 Applicability of the limits

The limit(s) specified for the first MP/N are valid for all the other MP/Ns listed in the same task.

Example:

24/36/01/000/000/050			
Starter generator	160SG140Q1 160SG140Q1XL	(7050A4243037) (7050A4243050)	900 FH
SKURKA.			100 FH

4.4 Changes to Part Numbers

Unless otherwise stated, the time limits and inspections apply to the component whose part number is listed in the MSM and to its future changes, including those not already indicated in this section. In this case, contact the Airbus technical support department to confirm the installation effectivity of the dash number.

5 LIMITS

A component or a maintenance operation can be subject to one or more limits, expressed in:

- flight hours,
- calendar time,
- cycles.

5.1 Flight Hours

- Flight Hours (FH), are counted from takeoff to landing.

5.2 Calendar time

Calendar time can be expressed:

- in Months (M),
- in Days (D),
- from the date marked on the equipment label (ED: Expiry Date).

5.2.1 Airframe initial aging date

The helicopter airframe initial aging date to be taken into account is the date marked on the helicopter identification plate.

5.2.2 Initial aging date for components

- The initial aging date for a component and a dynamic component to be taken into account is generally the date of first installation or first destorage, to be recorded on the equipment log card. In this case, there are no other specifications in the MSM tasks.

The storage time before installation is therefore not to be taken into account on the condition that storage was in accordance with the applicable documentation, except for the following specific cases.

- For some components, the aging date to be taken into account is the date of manufacture marked on the Log Card (FM). In this case, TSM (Time Since Manufacture) is specified in each task concerned in the MSM.

Specific cases:

Components or dynamic components are sometimes subject to a limit since installation and a limit since manufacture. In this case, both limits followed by TSI (Time Since Installation) and TSM (Time Since Manufacture) are indicated, as per the following example:

25/91/00/000/000/XXX					
Siren load release unit hook					
S1609-6	(704A41811027)	//	60 M	TSI TSM	180 D
			120 M		180 D
Storage limit (original package): 60 M.					

NOTE

If there is no log card, when the component arrives in the stores, it is advisable to create a "Follow-up Sheet" and to fill out the helicopter logbook when the component is installed. When the component is installed on the helicopter, the applicable date is the date of manufacture marked on the component's identification plate.

NOTE

Dynamic components, which have been subject to work in a specialized workshop or long-term storage in accordance with the applicable instructions during this period, may be subject to an extension to this calendar time limit.

In this case the operator must make a request with the Airbus Technical Support Department and obtain approval from the manufacturer and the Airworthiness Authorities.

5.3 Cycles

According to the component, the cycles can be expressed either as:

- **Takeoff/landing cycles:** LC (Landing Cycle)

1 LC = 1 takeoff/landing.

- **Sling cycles**: SC (Sling Cycle)
1 SC = 1 release with load on ground and 3 SC = 1 release in flight (load not on the ground).
- **Operating cycles**: OPC (OPERating Cycles)
The definition is specified in each concerned task.
- **Operating hours**: OPH (OPERating Hours)
The definition is specified in each concerned task.

5.4 Provisional limitations

The limits for which additional fatigue tests indicate the possibility of an extension, are identified by code "P" (Provisional). This code (P) follows the value of the limit in the tasks concerned.

The operator should therefore store the component in question after removal, pending a service life extension.

5.5 Periodic and Perform Once limits

The limits specified in section 05-2x-0x of the MSM must be complied with:

- **Periodically**: the maintenance operation must be performed at the latest when the indicated limit is reached.

NOTE

For operational reasons, the maintenance operation can be performed before the limit is reached, however, the maximum interval between two maintenance operations must be complied with.

or

- **Once only**: the maintenance operation must be performed once only, when the indicated limit is reached.

It must not be performed before the limit is reached.

These maintenance operations are identified by a dotted line around the task and by code PO (Perform Once) in front of the limit value.

These operations can be performed either:

- After installation of a component removed from the same helicopter,
- After the introduction to service of a new, overhauled or repaired component,
- After installation of a component originating from another helicopter,
- Each time after the component is installed.

The start of the maintenance operation is specified in each task concerned.

Example:

28/00/00/000/000/250			
Strainers			
	AMM 28-00-00, 6-3	PO &	10 FH 100 FH
			1 FH 10 FH
Each time after the component is installed.			
Check and cleaning.			
DI CLN			

5.6 Performance interval

Some components and maintenance operations are assigned several performance limits separated by the "/" or "&" sign.

In the case of limits separated by the "/" sign, the maintenance operation must be performed when the first limit is reached.

The next limit at which the component is to be rejected or the maintenance operation is to be performed will once again be the first limit reached.

In the case of limits separated by the "&" sign, the maintenance operation must be performed at each limit indicated.

Example 1:

25/91/00/000/000/000			
Load release unit hook			
	AS21-8-C	(7050A4259001)	60 M 1500 SC
			180 D 150 SC

Section 05-10-00

. A load release unit hook performs 1000 SC over a period of 60 M (TSI). The first limit reached by the load release unit hook therefore is 60 M; it must be removed for overhaul (TBO) and returned to service for another period.

. After overhaul, the load release unit hook is installed on a helicopter and then performs 1500 SC in 48 M (TSI). The first limit reached by the load release unit hook is therefore 1500 SC. It must therefore be removed for another overhaul (TBO).

Example 2:

28/00/00/000/000/250			
Strainers			
	AMM 28-00-00, 6-3	PO &	10 FH 100 FH
			1 FH 10 FH
Each time after the component is installed.			
Check and cleaning.			
DI CLN			

Section 05-26-00

The maintenance operation must be performed once at 10 FH and once at 100 FH after installation. The maintenance operation must be repeated only if the component is removed then reinstalled or replaced.

5.7 Specific and severe atmospheric operating conditions

Certain specific and severe climatic conditions are considered as specific operating conditions. This concerns the use of helicopters in the following conditions:

- Tropical and damp atmosphere:

- . Combination of high ambient temperatures and humidity levels (from +28°C (+82.4°F) and 75% relative humidity).
- Salt-laden atmosphere:
 - . Ship-based or,
 - . Based for more than 50% of its time less than 1 km from the coast or,
 - . Spending more than 50% of its time in offshore flight at low altitude (below 1,000 feet).
- Sand- and/or dust-laden atmosphere:
 - . Sand-laden wind and/or landing on sandy ground.
- Cold weather:
 - . Temperatures observed or forecast from -10°C to -30°C (+14°F to -22°F).
- Very cold weather:
 - . Temperatures observed or forecast from -30°C to -40°C (-22°F to -40°F).
- Hot climatic conditions:
 - . High solar temperature above +40°C (+104°F).

The scheduled maintenance relating to these operating conditions is covered with all the MSM tasks.

These operating conditions require not only the operations specified in the MSM and standard maintenance operations, but also the preventive measures recommended in **AMM task 12-30-00, 3-3**. Since the interval is not specified, the operator must reapply the measures according to his own experience in the corresponding conditions.

5.8 Maximum limit value

The maximum limit value represents the limit not to be exceeded. No tolerance is permitted on the maximum limit value.

The maximum limit value equals to a limit value + margin value.

5.8.1 Definition of the margin

To introduce "flexibility" into maintenance planning in order to compensate for unpredictable situations (e.g. unforeseeable increase in the helicopter utilization rate), Airbus defines a value, called "margin", to be added to a limit value.

This margin, added to the limit value to which it is applicable, results in the maximum limit value (limit value + margin value) to be taken into account for two consecutive inspections.

5.8.2 Application of the margin

The margin can be used repetitively for each limit value interval (refer to "example of how the margin is used").

However, to maintain certain "flexibility" in maintenance planning, Airbus recommends to plan the maintenance operation using the limit value without taking the margin into account.

5.8.3 Specification of the margin

The margin value and its units are specified as shown in the following example.

Example:

24/36/02/000/000/150				
Starter generator				
	524-061	(704A46101021)	2400 FH	240 FH
AUXILEC.				

No units are specified when the margin equals zero.

5.8.4 Example of how the margin is used

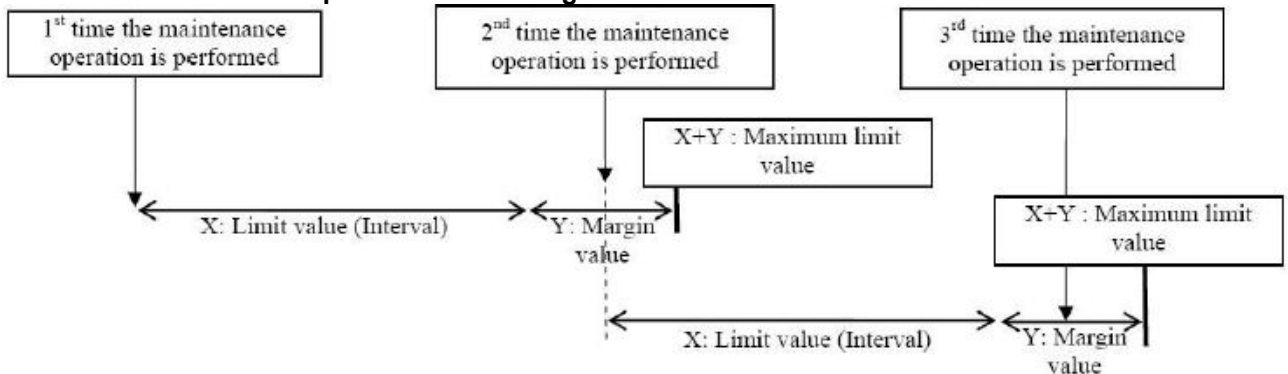

X is the limit value for performing the maintenance operation and Y is the margin value added to the limit value.

After using the first margin value (partially or completely), the next maintenance operation is to be performed again within the X+Y interval, that is to say before the next maximum limit value.

6 HELICOPTER-SERIALIZATION OF THE COMPONENTS

To ensure optimum technical follow-up of the components specified in MSM Chapters 04 and 05, the components are to be identified according to the serial number of the helicopter.

6.1 Principle

Any components used on EC120 helicopters with serial numbers from 8001 up to 8999 inclusive must be identified by indelible marking of the letters (HC) near to the part numbers of these components.

For example : - [HC] C632A0201054 for a main module - used on an EC120 helicopter with a serial number from 8001 up to 8999 inclusive.

No additional identification is necessary for a component used on a helicopter with a serial number from 1001 up to 7999 inclusive.

6.2 Identification marking

The identification marking is to be recorded on the component at the latest upon its first removal.

However, the log card of the component concerned or of its next higher assembly is to be completed as soon as the component is installed on the helicopter.

7 TRANSFER OF A COMPONENT (PART OR ASSEMBLY) FROM ONE HELICOPTER TO ANOTHER HELICOPTER

Transfer rules

Components with no additional identification marking are authorized for installation on all EC120 helicopters regardless of their serial numbers.

Components with part numbers identified by the letters [HC] are authorized for installation only on EC120 helicopters with serial numbers from 8001 up to 8999 inclusive. It is prohibited to install these components on EC120 helicopters with serial numbers from 1001 up to 7999 inclusive.

When a component or assembly, either new, revised or from another aircraft, is fitted on an aircraft, the operator must record in the aircraft log book or the equipment log card its origin and the number of hours available before the next removal.

8 RECORDING

In all cases record the transfer information and calculation on the log card of the component concerned.

An individual log card must be drawn up if the component has been monitored via the log card of its higher assembly.

9 SCHEDULED MAINTENANCE CHECKS – MAINTENANCE OPERATIONS

9.1 Particular inspection cases

In certain cases, a visual inspection without removal or disassembly is specified and the noted operation is a thorough inspection with part removed. In this case, the operator must check the visible sections of the part with reference to the detailed inspection criteria.

9.2 Rules of procedure

Even though it is not indicated for each check, whenever possible, confirm that the surrounding structure is in good condition: it is free from cracks, the condition of the riveting, the protection of the sealant beads.

During an inspection, if the results are not conclusive or if a fault is found on an assembly, a component or an attachment, do the detail checks that will confirm the condition and determine the steps to be taken.

Before installing a component on the aircraft, the operator must check its condition.

Before you start the work:

- Review the failures indicated in the aircraft log book.
- Check the expiration date of the hoses.
- Do a flight-related check.

When the work is finished:

- Confirm that all the failures have been satisfactorily repaired.
- Summarize the failures for which the repair has been deferred (with the approval of the local authority).
- Do a flight-related check.

10 STORAGE HELICOPTER

10.1 Helicopter in flight conditions - Parking

A helicopter is considered as operational (in flight conditions) when a flight (including at least 1 take off/landing phase) with a 20mins minimum duration is performed over the last 14 days.

In such case, helicopter parking shall take place under a sheltered area* or unsheltered area* (* refer to § 10.5).

After more than 14 days without a flight, operators shall comply with the associated helicopter storage procedures:

- Outdoor short term storage for under unsheltered storage

- Another storage for under sheltered storage

10.2 Storage duration « T0 » definition

Storage Type	Immobilization	Short	Term	Long	Term	Cocoon Storage
Storage beginning "T0"		Storage		Sheltered Storage		
Condition(s)	When Immobilization period follows a Parking : ➤ "T0" to be considered is the date of the last flight performed (for a minimum duration of 20 minutes) over the past 14 days maximum (time since T0 must not exceed 14 days).	➤ "T0" to be considered is the date of the last ground run performed with storage oil inside the MGB, IGB and TGB ➤ The Storage preparation operations shall be completed within a maximum of 14 days ➤ The same 14 days tolerance is also applicable at the end of the storage period for the reactivation operations.				

NOTE

For engine, please refer to the EMM for specific T0 identification

10.3 Renewal procedure

The renewal storage operations shall take place within a 14-day maximum tolerance after the end of the previous storage duration.

10.4 Storage inspection tolerance

All storage inspections values defined in this Technical Note are subjected to tolerance that represents ±10% of the storage inspection value.

For example: a storage inspection required every 2 months could be carried out 6 days before or 6 days after the limit value of 2 months.

10.5 Sheltered/Unsheltered Area

Any facilities intended to protect helicopter from precipitation (Rain, snow, hail, sleet) and direct sun/moon lights are considered as a sheltered area. The sheltered areas shall be either closed (Closed hangar compliant with Part 145 or FAA equivalent definition) or shall be a Cocoon when helicopter is stored in an environment with severe climatic conditions as defined below:

- Damp Tropical atmosphere (Combination of high ambient temperature and humidity level)
- Salt-laden atmosphere (helicopter based onboard a ship or within 1 km away from the coast)
- Sand-laden atmosphere or Dust-laden atmosphere (Sand-laden wind or in a sandy areas)
- Cold and Hot

The unsheltered areas shall be considered when the above requirements are not met.

Please note that this document is not restrictive and the customers remain free to decide to remove the parts they consider useful according to the mission spectrum, environmental and atmospheric conditions where helicopter is operated. However, in order to preserve helicopter in optimal storage conditions, Airbus recommends different types of storage according to outside climatic conditions.

Please, follow storage procedure in compliance with these recommendations:

Climatic Conditions	Normal	Tropical & Damp atmosphere ⁽¹⁾	Dust and/or Sand laden atmosphere	Salt-laden atmosphere ⁽²⁾	Cold or Hot ⁽³⁾
Storage Type					
Immobilization Sheltered	+++	+	+++	+++	+++
Short-Term Unsheltered	+	o	+	o	Contact AH
Short-Term Sheltered	+++	+	+++	+++	+++
Long-Term Sheltered	+++	+++	+++	+++	+++
Cocoon	+++	+++	+++	+++	+++

+++ : Preferred Storage method + : Acceptable Storage method o : Storage method to follow in last alternative

⁽¹⁾ Combination of high ambient Temperatures (+28°C) and Humidity levels (75%)

⁽²⁾ Storage located at less than 1km from the coast

⁽³⁾ Temperatures below -15°C and above +40°C

11 MAINTENANCE CODES (MC)

To make it easier to perform the maintenance operations, each maintenance operation included in section 05-20 and 04-20 is identified by one or mode codes as listed below:

- LUBrication/SerViCing (**LUB/SVC**)

This includes work such as routine lubrication and servicing, filling/topping-up of oils, fluids, liquids and checking of pressures.

- Visual Check (**VC**)

Visual inspection, without removal of the physical condition of certain components such as oil levels, tire wear, accumulator pressure, etc.

- General Visual check (**GVI**)

A general visual check is a visual inspection, without removal, to detect and assess deterioration or incorrect operation of a component or assembly. This check may require access equipment, ladders or platforms, and inspection means, mirror, light or screwdriver. The doors and hatches are opened or removed in order to access the components.

- Detailed Inspection (**DI**)

A detailed inspection is an inspection to detect and assess deterioration or incorrect operation of a component or assembly. This inspection may require access equipment, ladders, platforms and specific tools, and may require removal of the component or assembly. The doors and hatches are open or removed.

- Special Detailed Inspection (**SDI**)

A special detailed inspection is an inspection to detect and assess deterioration or incorrect operation of a component or assembly. This inspection may require a specific process such as dye penetrant inspection, radiography, etc.

- Functional Test (**FT**)

A functional test/check is a test which is performed to determine whether one or more functions of a system operate within stipulated limits. Normally this test is performed without the removal of components and using a maintenance tool.

- CLeaNing (**CLN**)

To remove dirt and/or foreign bodies from a system or surface. Cleaning may require removal of the component, such as for a filter for example.

- DiScard (**DS**)

A component is withdrawn from service at a specified limit. Discarding normally applies to parts such as cartridges, containers, cylinders, batteries, etc.

- ReStoration (**RS**)

This work involves restoring a component to a specific standard. Restoration can vary from cleaning or replacing detail parts to a complete overhaul.

- Readjustment of the TorQque loading (Retorque) (**RTQ**)

Readjustment is a maintenance procedure which consists in applying the tightening torque to an assembly, without checking its value.

- Torque Check (**TCK**)

The aim of the torque check procedure is to check that the tightening torque of the assembly is not below the specified minimum value.

- WeiGHing (**WGH**)

The aim is to remove the equipment in order to weigh it using scales, to check its integrity and to make sure that there are no losses.

- New Proof Test (**NPT**)

The aim is to perform a proof pressure test to check that there are no leaks.

- DRaiNing (**DRN**)

Draining/replenishing consists in replacing all the fluid, liquid, oil or fuel in a component.

- Ground Run (**GR**)

A ground run consists in checking certain parameters of a component or a function with the rotor spinning or dynamically after operation.

- RigglN (**RIG**)

Rigging consists in adjusting a control channel or a set of components which must have an operating range in operation.

12 CONTENT OF A TASK

Section 05-1x-00

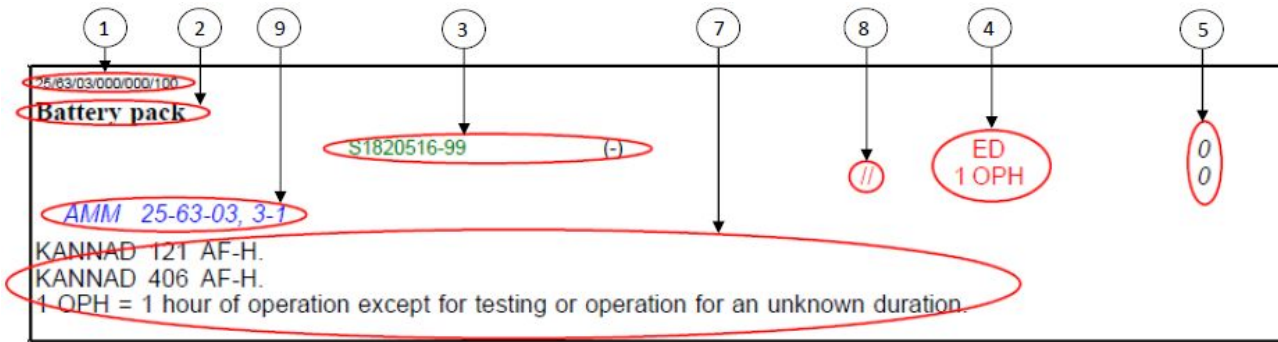

Section 05-2x-0x

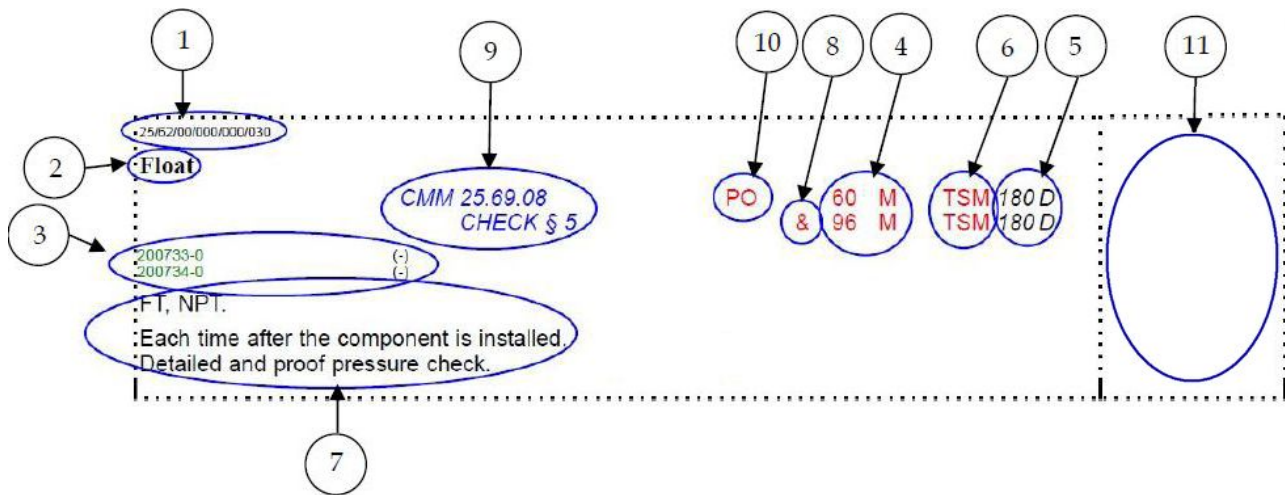

End of section

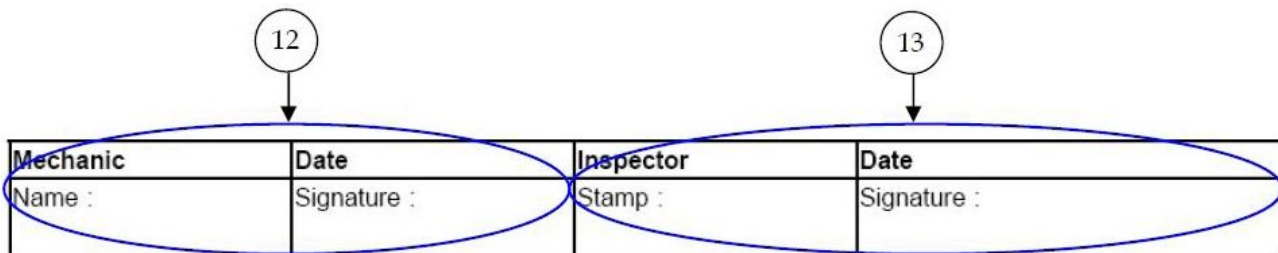

- 1 - Task number (refer to the DU: "STRUCTURE OF THE MSM" - § 2.2)
- 2 - Designation
- 3 - Equipment manufacturer's part number and the Airbus management number (refer to § 4)
- 4 - Limit value(s) and unit(s) (refer to § 5.1 / 5.2 / 5.3)
- 5 - Margin value(s) and unit(s) (refer to § 5.8)
- 6 - Start of the limit (TSI, TSM) if necessary (refer to § 5.2.1 / 5.2.2)
- 7 - Comments if necessary
- 8 - //: or - &: and (refer to § 5.6)
- 9 - Reference documentation AMM, CMM, ...
- 10 - Perform Once operation (refer to § 5.5)
- 11 - Initial: Date of application and mechanic signature
- 12 - Mechanic: Date, name and signature
- 13 - Inspector: Date, stamp and signature

End of the Document Unit

OPTIONAL

1 COMPATIBILITY / INCOMPATIBILITY

A helicopter can be equipped with various optional items. There can be incompatibilities between certain optional installations which can appear at two levels:

- At operational level:
In this case, incompatibilities between optional items are specified in the Flight Manual.
- At installation on the helicopter:
 - Either it is impossible to install the fixed parts at the same time.
 - Or there is total or partial installation incompatibility of the removable parts at the same time.

The following table lists all the approved optional installations with their incompatibilities or effects on operation, as specified in a Flight Manual Supplement.

2 TABLE OF APPROVED OPTIONAL INSTALLATIONS

N°	EFFECTIVITY	TYPE OF INSTALLATION	Fixed parts	Removable parts
			INCOMPATIBLE TO INSTALL AT THE SAME TIME	TOTAL OR PARTIAL INSTALLATION INCOMPATIBILITY AT THE SAME TIME
1	B	Reinforced ventilation	2	-
2	B	Air conditioning system	1	-
3	B	Heating very cold weather	-	-
4	B	Sand protection main rotor blades	-	-
5	B	T.B. external plug	-	-
6	B	T.B. (GMA.340H)	-	-
7	B	Headset (D. Clark H10-13H)	-	-

N°	EFFECTIVITY	TYPE OF INSTALLATION	Fixed parts	Removable parts
			INCOMPATIBLE TO INSTALL AT THE SAME TIME	TOTAL OR PARTIAL INSTALLATION INCOMPATIBILITY AT THE SAME TIME
8	B	Emergency locator transmitter Kannad 121 AF-H "BI"	9	-
9	B	Emergency locator transmitter Kannad 406 AF-H "TRI"	8	-
10	B	Sand filter	-	-
11	B	Engine rinsing	-	-
12	B	Flowmeter	-	-
13	B	Carpet	18,54	17
14	B	Comfort upholstery	18	-
15	B	Reinforced sound-proofing	-	-
16	B	Hold door upholstery	54	-
17	B	Plastic floor cabin	18, 54	13
18	B	Furnishing "stylece"	13, 14, 17, 54	-
19	B	Furnishing "stylece"	-	-
20	B	First-aid kit	-	-

N°	EFFECTIVITY	TYPE OF INSTALLATION	Fixed parts	Removable parts
			INCOMPATIBLE TO INSTALL AT THE SAME TIME	TOTAL OR PARTIAL INSTALLATION INCOMPATIBILITY AT THE SAME TIME
21	B	Hydraulic ground power protection	-	-
22	B	Reheating battery for starting very cold weather	23	-
23	B	Additional battery 15A/H	22	-
24	B	Swivel landing light	-	-
25	B	Gyroscopic horizon (H.321-EGM)	-	-
26	B	Antenna glide	-	-
27	B	Honeywell chain course (KCS.55A) avec HSI KI 525A	-	-
28	B	DME (KN.63A) King	-	-
29	B	Transponder (GTX.327 "Garmin") + Shadin 8800T	33	-
30	B	Chronometer	-	-
31	B	Vertical speed indicator (DIA.80)	-	-
32	B	Transformation of basic equipment into JVN (VEMD, CWP)	-	-
33	B	GTX.330 Mode S "Garmin" transponder + Shadin 8800T	29	-

N°	EFFECTIVITY	TYPE OF INSTALLATION	Fixed parts	Removable parts
			INCOMPATIBLE TO INSTALL AT THE SAME TIME	TOTAL OR PARTIAL INSTALLATION INCOMPATIBILITY AT THE SAME TIME
34	B	AHV16 radio altimeter + indicator 210	-	-
35	B	Dual controls	-	-
36	B	Pilot cyclic stick grip (R.)	-	-
37	B	Pilot cyclic stick grip (L.)	-	-
38	B	VHF/ AM N°2 (KY.196A).	-	-
39	B	VHF/ VOR/ GPS (GNS.430 "GARMIN")	-	-
40	B	VHF/ AM (KY.196 SC+ "KING")	-	-
41	B	Cargo Sling (F.P)	-	-
42	B	Cargo Sling (R.P)	-	-
43	B	Electric mirror	-	-
44	B	Emergency floatation gear (F.P)	49	-
45	B	Emergency floatation gear (R.P)		-
46	B	Windshield wiper	-	-
47	B	Cable cutter	-	-

N°	EFFECTIVITY	TYPE OF INSTALLATION	Fixed parts	Removable parts
			INCOMPATIBLE TO INSTALL AT THE SAME TIME	TOTAL OR PARTIAL INSTALLATION INCOMPATIBILITY AT THE SAME TIME
48	B	Skis (F.P)	45, 51	-
49	B	Skis (R.P)		-
50	B	Reinforced mettalic base plates	51	-
51	B	Long reinforced mettalic base plates	49, 50	-
52	B	Rolling on loose ground	-	-
53	B	Unfolding stretcher (F.P)	13, 16, 17, 18	-
54	B	Unfolding stretcher (R.P)		-
55	B	Blade rotor type light	-	-

End of the Document Unit

SB INCORPORATED

Airbus is required to issue Service Bulletins (SB) subsequent to new events (incidents, etc).

The information contained in the SBs is incorporated in the MSM if, and only if:

The SB contains new periodic checks, or modifies the existing MSM limitations.

The table below specifies for each SB incorporated:

- the number of the SB and its revision number,
- the subject of the SB,
- the ATA chapter/section concerned,
- the date on which the SB is incorporated in the MSM.

SB N°	Subject	ATA	AD number	Incorporation date
62-010	Increasing the blade clearance from tail boom	62-21		–
63-012	Check of the MGB main module tapered pin attaching cones	63-22		–
05-007	Calendar check for corrosion on main rotor head attack beams	62-21		–
05-009	Lubrication of the couplings of the non-rotating and rotating scissors	62-32		–
05-010R1	Emergency floatation gear float cover	25-67		–
05A011	Emergency floatation gears: periodic check of the floats with intervals in hours	25-67		–
62-004 R1	Improvement of the balance weight attachment fittings on the MRH	62-21		–
05-013	SKURKA (ex APC) starter-generators (MP/N) 160SG140Q1 and 160SG140Q1XL	24-36		–
25A026	Protector installation on the rear bracket and the supply couplings	25-67		–
53A015	Corrosion on the tail boom	53-50		2015.04.09
53A015 R1	Corrosion on the tail boom	53-50		2016.04.28
53A017	Rear fuselage - Corrosion on the tail boom	53-50		2021.07.05

End of the Document Unit

05-10-00

D.U.	TITLE
ATA 24	ELECTRICAL POWER
ATA 25	EQUIPMENTS AND FURNISHINGS
ATA 63	MAIN ROTOR DRIVE
ATA 65	TAIL ROTOR DRIVE
ATA 67	ROTORS FLIGHT CONTROLS

Task Number Description/Remarks	MP/N (PN)	Type of limit: TBO	Margin
------------------------------------	-----------	--------------------	--------

24 - ELECTRICAL POWER

24-36 STARTER/GENERATOR

24/36/01/000/000/050 Starter generator SKURKA. TSM or Overhaul.	160SG140Q-1 (7050A4243037) 160SG140Q-1-XL (7050A4243050)	// 900 FH 60 M TSM	100 FH 0
24/36/01/000/000/500 Starter generator SKURKA. TSM or Overhaul.	160SG140Q-4 (7050A4243054)	// 1200 FH 60 M TSM	120 FH 0
24/36/02/000/000/150 Starter generator THALES. TSM or Overhaul.	524-061 (704A46101021)	// 1200 FH 60 M TSM	20 FH 0

25 - EQUIPMENTS AND FURNISHINGS

25-91 CARGO SLING

25/91/00/000/000/000 Load release unit hook	AS21-8-C (7050A4259001)	// 60 M 1500 SC	180 D 150 SC
---	-------------------------	--------------------	-----------------

63 - MAIN ROTOR DRIVE

63-21 MGB EPICYCLIC MODULE

63/21/00/000/000/250 Epicyclic module	C632A0101051 (-)	// 2000 FH 288 M	200 FH 180 D
---	------------------	---------------------	-----------------

Task Number Description/Remarks	MP/N (PN)	Type of limit: TBO	Margin
------------------------------------	-----------	--------------------	--------

63/21/00/000/000/260 Epicyclic module	C632A0101052 (-)	// 5000 FH 288 M	300 FH 180 D
---	------------------	---------------------	-----------------

63-22 MGB MAIN MODULE

63/22/00/000/000/600 Main module	C632A0201051 (-)	// 2000 FH 288 M	200 FH 180 D
--	------------------	---------------------	-----------------

63/22/00/000/000/620 Main module	C632A0201052 (-) C632A0201053 (-)	// 3750 FH 288 M	300 FH 180 D
--	--------------------------------------	---------------------	-----------------

63/22/00/000/000/630 Main module	C632A0201054 (-)	// 5000 FH 288 M	300 FH 180 D
--	------------------	---------------------	-----------------

65 - TAIL ROTOR DRIVE

65-21 TAIL GEARBOX

65/21/00/000/000/040 TGB	C652A0101051 (-) C652A0101054 (-)	// 1800 FH (P) 288 M	180 FH 180 D
------------------------------------	--------------------------------------	-------------------------	-----------------

65/21/00/000/000/050 TGB	C652A0101052 (-) C652A0101053 (-)	// 2500 FH (P) 288 M	250 FH 180 D
------------------------------------	--------------------------------------	-------------------------	-----------------

65/21/00/000/000/060 TGB	C652A0101055 (-)	// 5000 FH 288 M	300 FH 180 D
------------------------------------	------------------	---------------------	-----------------

Task Number Description/Remarks	MP/N (PN)	Type of limit: TBO	Margin
------------------------------------	-----------	--------------------	--------

67 - ROTORS FLIGHT CONTROLS

67-31 SERVOCONTROLS

67/31/00/000/000/100			
Servocontrol	SC5091 SC5091-1	(7050A4673005) (7050A4673006)	4000 FH 300 FH 240 M TSM 180 D
TSM or Overhaul.			

End of the Document Unit

05-11-00

D.U.	TITLE
ATA 21	AIR CONDITIONING
ATA 25	EQUIPMENTS AND FURNISHINGS
ATA 26	FIRE PROTECTION
ATA 31	INDICATING & RECORDING SYSTEMS
ATA 62	MAIN ROTOR
ATA 65	TAIL ROTOR DRIVE

Task Number Description/Remarks	MP/N (PN)	Type of limit: OTL	Margin
------------------------------------	-----------	--------------------	--------

21 - AIR CONDITIONING

21-51 COOLING

21/51/00/000/000/050				
Belt	4PK730	(7050A3632293)	1500 FH // 72 M	150 FH 180 D

25 - EQUIPMENTS AND FURNISHINGS

25-63 EMERGENCY LOCATOR TRANSMITTER

25/63/01/000/000/050				
Battery pack	JE2-1978-3	(N6742450122)	ED	0
	JE2-1978-3NG	(NR003100026)	// 1 OPH	0
JOLLIET JE2/JE2NG. 1 OPH = 1 hour of operation except for testing or operation for an unknown duration.				

25/63/02/000/000/060				
Battery pack	ELT90A2560102001	(-)	48 M TSM // 1 OPH	0
SOCATA. Battery unit assy (emergency locator transmitter battery unit + shock detector battery unit). 1 OPH = 1 hour of operation except for testing or operation for an unknown duration.				

25/63/03/000/000/100				
Battery pack	S1820516-99	(-)	ED // 1 OPH	0
<i>AMM 25-63-03, 3-1</i> KANNAD 121 AF-H. KANNAD 406 AF-H. 1 OPH = 1 hour of operation except for testing or operation for an unknown duration.				

25-67 EMERGENCY FLOATATION GEAR

25/67/00/000/000/000				
Cylinder	215494-0	(7050A4256002)	180 M TSM	0
	215494-1	(7050A4256009)		
Return the equipment to an approved repairer for Overhaul and replacement of the bare cylinder.				

Task Number Description/Remarks	MP/N (PN)	Type of limit: OTL	Margin
------------------------------------	-----------	--------------------	--------

25/67/00/000/000/150

Float

215674-0	(7050A4256000)	180 M	TSM	0
215674-1	(7050A4256005)			
215674-2	(7050A4256007)			
215674-3	(7050A4256020)			
215675-0	(7050A4256001)			
215675-1	(7050A4256006)			
215675-2	(7050A4256008)			
215675-3	(7050A4256021)			

If you wish to apply for an extension, return the assembly in question to the manufacturer for it to be examined.
Remove the complete assembly after a ditching.

25/67/00/000/000/200

Cover assembly

215732-0	(-)	180 M	TSM	180 D
215732-1	(-)			
215733-0	(-)			
215733-1	(-)			
216826-0	(-)			
216826-1	(-)			
216827-0	(-)			
216827-1	(-)			

AMM 25-67-00, 4-1

If you wish to apply for an extension, return the assembly in question to the manufacturer for it to be examined.

26 - FIRE PROTECTION

26-22 CABIN EXTINGUISHER

26/22/00/000/000/050

Cabin fire extinguisher

PLA863520-00	(T262M50T0002)	60 M	TSM	0
--------------	----------------	------	-----	---

26/22/00/000/000/100

Cabin hand fire extinguisher

12085-01	(S262A10T1001)	120 M	TSM	0
H1-10AIR	(704A32810008)			

31 - INDICATING & RECORDING SYSTEMS

31-21 CLOCK / CHRONOGRAPH

31/21/00/000/000/000

Chronometer - Lithium battery

CR 2032	(-)	48 M		146 D
---------	-----	------	--	-------

THOMEN DC20.

Task Number Description/Remarks	MP/N (PN)	Type of limit: OTL	Margin
------------------------------------	-----------	--------------------	--------

62 - MAIN ROTOR

62-31 SWASHPLATE ASSEMBLY

<small>62/31/00/000/000/050</small> Swashplate - Bearing FAG.	7050A3623013 (7050A3623013)	3000 FH	0
<small>62/31/00/000/000/060</small> Swashplate - Bearing SNR.	7050A3623019 (7050A3623019)	5300 FH	0

65 - TAIL ROTOR DRIVE

65-11 TAIL ROTOR DRIVE SHAFT

<small>65/11/00/000/000/030</small> Tail rotor drive bearing	7050A3651001 (-)	3000 FH	0
--	-------------------------	---------	---

End of the Document Unit

05-20-00

BFF

ALF

D.U.	TITLE
ATA 05	TIME LIMITS/MTCE. CHKS

Task Number Description/ Remarks	Documentation	Margin	Initial
--	----------------------	---------------	----------------

05 - TIME LIMITS/MTCE. CHKS

05-30 FLIGHT-RELATED CHECKS OF THE DAY

05/30/00/000/000/000	<p>Check before the first flight of the day (BFF) - Optional equipments <i>AMM 05-30-00, 6-2</i></p> <p>0</p> <p>Inspection. Note: Operations can be carried out by an aircrew member. VC</p>	
05/30/00/000/000/010	<p>Preparation for inspection (BFF) <i>AMM 05-30-00, 6-3</i></p> <p>0</p> <p>Cold weather Very cold weather</p> <p>Inspection. VC</p>	
05/30/00/000/000/020	<p>Check after the last flight of the day (ALF) - Optional equipments <i>AMM 05-30-00, 6-2</i></p> <p>0</p> <p>Inspection. Note: Operations can be carried out by an aircrew member. VC</p>	
05/30/00/000/000/030	<p>Preparation for inspection (ALF) <i>AMM 05-30-00, 6-3</i></p> <p>0</p> <p>Cold weather Very cold weather</p> <p>Inspection. VC</p>	

Mechanic	Date	Inspector	Date
Name :	Signature :	Stamp :	Signature :

End of the Document Unit

05-20-02**15 FH // 7 D**

D.U.	TITLE
ATA 05	TIME LIMITS/MTCE. CHKS
ATA 53	FUSELAGE

Task Number Description/ Remarks	Documentation	Margin	Initial
-------------------------------------	---------------	--------	---------

05 - TIME LIMITS/MTCE. CHKS

05-30 FLIGHT-RELATED CHECKS OF THE DAY

<p>05/30/00/000/000/040</p> <p>Daily check</p> <p style="text-align: center;"><i>AMM 05-30-00, 6-1</i></p> <p style="text-align: right;">0 0</p> <p>Note: Operations can be carried out by an aircrew member. VC</p>	
<p>05/30/00/000/000/050</p> <p>Daily check - Optional equipments</p> <p style="text-align: center;"><i>AMM 05-30-00, 6-4</i></p> <p style="text-align: right;">0 0</p> <p>Note: Operations can be carried out by an aircrew member. VC</p>	

53 - FUSELAGE

53-00 FUSELAGE

<p>53/00/00/000/000/060</p> <p>Structure</p> <p style="text-align: center;"><i>AMM 12-20-00, 3-2</i></p> <p style="text-align: right;">0 0</p> <p>Salt-laden atmosphere Rinsing and Drying. CLN</p>	
--	--

Mechanic	Date	Inspector	Date
Name :	Signature :	Stamp :	Signature :

End of the Document Unit

05-21-00**100 FH // 12 M**

D.U.	TITLE
ATA 25	EQUIPMENTS AND FURNISHINGS
ATA 32	LANDING GEAR
ATA 56	WINDSHIELD / TRANSPARENT PANEL / WINDOW DOOR
ATA 62	MAIN ROTOR
ATA 63	MAIN ROTOR DRIVE
ATA 64	TAIL ROTOR
ATA 65	TAIL ROTOR DRIVE
ATA 71	POWER PLANT

Task Number Description/ Remarks	Documentation	Margin	Initial
-------------------------------------	---------------	--------	---------

25 - EQUIPMENTS AND FURNISHINGS

25-21 CREW SEATS

<p>25/21/00/000/000/010</p> <p>Pilot and copilot harnesses</p> <p style="text-align: center;"><i>AMM 25-21-00, 6-2</i></p> <p>10 FH 36 D</p> <p>159110 (7050A4252005) 1591718-04 (7050A4252001) 1591718-06 (7050A4252012)</p> <p>Check. DI</p>	
---	--

25-22 PASSENGERS SEATS

<p>25/22/00/000/000/010</p> <p>Bench harnesses</p> <p style="text-align: center;"><i>AMM 25-22-00, 6-2</i></p> <p>10 FH 36 D</p> <p>FHEC1-310002-01 (7050A3252003) FHEC1-31EC03-01 (7050A3252010)</p> <p>Check. DI</p>	
--	--

25-63 EMERGENCY LOCATOR TRANSMITTER

<p>25/63/03/601/000/080</p> <p>Emergency locator transmitter</p> <p style="text-align: center;"><i>AMM 25-63-03, 6-1</i></p> <p>10 FH 36 D</p> <p>KANNAD 121 AF-H. KANNAD 406 AF-H. Check. DI FT</p>	
--	--

Task Number Description/ Remarks	Documentation	Margin	Initial
-------------------------------------	---------------	--------	---------

32 - LANDING GEAR

32-17 SKIS

<p>32/17/00/000/000/010</p> <p>Ski</p> <p>Detailed check. DI</p>	<p><i>AMM 32-17-00, 6-2</i></p>	<p><i>10 FH 36 D</i></p>	
---	---------------------------------	------------------------------	--

56 - WINDSHIELD / TRANSPARENT PANEL / WINDOW DOOR

56-11 CABIN TRANSPARENT PANELS

<p>56/11/00/000/000/000</p> <p>Transparent panel</p> <p>Check. GVI</p>	<p><i>AMM 56-11-00, 6-2 AMM 56-11-00, 6-3 AMM 56-31-00, 6-1</i></p>	<p><i>10 FH 36 D</i></p>	
---	---	------------------------------	--

62 - MAIN ROTOR

62-21 MAIN ROTOR HUB

<p>62/21/00/000/000/765</p> <p>Droop restrainer ring</p> <p>Greasing. LUB</p>	<p><i>AMM 62-21-00, 4-2</i></p>	<p><i>10 FH 36 D</i></p>	
<p>62/21/00/000/000/770</p> <p>Anti-vibrator</p> <p>Greasing. LUB</p>	<p><i>AMM 62-21-00, 3-1</i></p>	<p><i>10 FH 36 D</i></p>	

Task Number Description/ Remarks	Documentation	Margin	Initial
-------------------------------------	---------------	--------	---------

62-31 SWASHPLATE ASSEMBLY

<p>62/31/00/000/000/100</p> <p>Swashplate</p> <p>Greasing. LUB</p>	<p><i>AMM 62-31-00, 3-1</i></p>	<p>10 FH 36 D</p>	
---	---------------------------------	-----------------------	--

62-32 FLARED HOUSING / SWASHPLATES / HUB COUPLINGS

<p>62/32/00/000/000/310</p> <p>Non-rotating and rotating scissors - Carbide rings</p> <p>Greasing. LUB</p> <p>Sand-laden and/or dust-laden atmosphere</p>	<p><i>AMM 62-32-00, 3-1</i></p>	<p>10 FH 36 D</p>	
--	---------------------------------	-----------------------	--

63 - MAIN ROTOR DRIVE

63-00 MAIN ROTOR DRIVE

<p>63/00/00/000/000/050</p> <p>MGB - Chip detector</p> <p>Check. FT DI</p>	<p><i>AMM 20-10-00, 3-6</i></p>	<p>10 FH 36 D</p>	
---	---------------------------------	-----------------------	--

63-11 MGB / ENGINE COUPLING

<p>63/11/00/000/000/050</p> <p>Flexible coupling</p> <p>Visual check. GVI</p>	<p><i>AMM 63-11-00, 6-3</i></p>	<p>10 FH 36 D</p>	
--	---------------------------------	-----------------------	--

Task Number Description/ Remarks	Documentation	Margin	Initial
-------------------------------------	---------------	--------	---------

<p>63/11/00/000/000/210</p> <p>Arm assy ball joint</p> <p>Play check. DI</p>	<p><i>AMM 63-11-00, 6-7</i></p>	<p><i>10 FH 36 D</i></p>	
---	---------------------------------	------------------------------	--

63-51 ROTOR BRAKE

<p>63/51/00/000/000/050</p> <p>Starting interlock</p> <p>Functional test. FT</p>	<p><i>AMM 63-51-00, 5-1</i></p>	<p><i>10 FH 36 D</i></p>	
---	---------------------------------	------------------------------	--

64 - TAIL ROTOR

64-21 TAIL ROTOR HUB

<p>64/21/00/000/000/050</p> <p>Blade/Bearing</p> <p>Play checks. DI</p>	<p><i>AMM 64-21-00, 6-1</i></p>	<p><i>10 FH 36 D</i></p>	
<p>64/21/00/000/000/100</p> <p>Blade/Shroud</p> <p>Play checks. DI</p>	<p><i>AMM 64-21-00, 6-2</i></p>	<p><i>10 FH 36 D</i></p>	

Task Number Description/ Remarks	Documentation	Margin	Initial
<p>64/21/00/000/000/150</p> <p>Tail rotor hub</p> <p>AMM 64-21-00, 6-4 AMM 64-21-00, 6-5 AMM 64-21-00, 6-6 AMM 64-21-00, 6-7 AMM 64-21-00, 6-8 AMM 64-21-00, 6-9 AMM 64-21-00, 6-10 AMM 64-21-00, 6-11 AMM 64-21-00, 6-12 AMM 64-21-00, 6-13 AMM 64-21-00, 6-14 AMM 64-21-00, 6-15 AMM 64-21-00, 6-16</p> <p>Removal of fairing and visual check of all components without disassembly. DI</p>		<p>10 FH 36 D</p>	

65 - TAIL ROTOR DRIVE

65-11 TAIL ROTOR DRIVE SHAFT

<p>65/11/00/000/000/100</p> <p>Cover plate</p> <p>AMM 65-11-00, 6-19</p> <p>Visual check. VC</p>		<p>10 FH 36 D</p>	
<p>65/11/00/000/000/750</p> <p>Bearing</p> <p>AMM 65-11-00, 3-1</p> <p>Greasing. LUB</p>		<p>10 FH 36 D</p>	
<p>65/11/00/000/000/850</p> <p>Flexible coupling</p> <p>AMM 65-11-00, 6-4</p> <p>Visual check. VC</p>		<p>10 FH 36 D</p>	

Task Number Description/ Remarks	Documentation	Margin	Initial
--	----------------------	---------------	----------------

65-21 TAIL GEARBOX

65/21/00/000/000/250 TGB - Chip detector Inspection. FT DI	<i>AMM 20-10-00, 3-6</i>	<i>10 FH</i> <i>36 D</i>	
--	--------------------------	-----------------------------	--

71 - POWER PLANT

71-63 SAND FILTER

71/63/00/000/000/000 Sand filter Condition check. GVI	<i>AMM 71-63-00, 6-1</i>	<i>10 FH</i> <i>36 D</i>	
---	--------------------------	-----------------------------	--

Mechanic	Date	Inspector	Date
Name :	Signature :	Stamp :	Signature :

End of the Document Unit

05-21-01**100 FH**

D.U.	TITLE
ATA 52	DOORS
ATA 62	MAIN ROTOR

Task Number	Documentation	Margin	Initial
Description/ Remarks			

52 - DOORS

52-33 PANEL OF COMMUNICATION

52/33/00/000/000/000	Communicating panel between cabin and cargo compartment <p style="text-align: right;"><i>AMM 52-33-00, 6-1</i></p> <p>C523S3101051 (C523S3101051) C523S3101052 (C523S3101052)</p> <p>Condition check. To be carried out on the aircraft with rear bench removed. GVI</p>	10 FH	
----------------------	---	-------	--

62 - MAIN ROTOR

62-11 MAIN ROTOR BLADES

62/11/00/000/000/210	Main rotor blade <p style="text-align: right;"><i>AMM 12-20-00, 3-1</i> <i>AMM 62-11-00, 4-1</i> <i>AMM 62-11-00, 6-1</i></p> <p>Tropical and damp atmosphere Salt-laden atmosphere</p> <p>Cleaning and visual check with removal. CLN DI</p>	10 FH	
----------------------	---	-------	--

Mechanic	Date	Inspector	Date
Name :	Signature :	Stamp :	Signature :

End of the Document Unit

05-21-02**12 M**

D.U.	TITLE
ATA 24	ELECTRICAL POWER
ATA 25	EQUIPMENTS AND FURNISHINGS
ATA 26	FIRE PROTECTION
ATA 34	NAVIGATION
ATA 53	FUSELAGE

Task Number Description/ Remarks	Documentation	Margin	Initial
-------------------------------------	---------------	--------	---------

24 - ELECTRICAL POWER

24-33 BATTERY

<p>24/33/00/000/000/060</p> <p>Battery</p> <p style="text-align: center;"><i>CMM 24.33.96</i> <i>CHECK § 2.2</i></p> <p>150CH-1 (7050A4243027) 151CH-1 (7050A4243040) 151CH-2 (7050A4243039)</p> <p>Check. DI</p>	<p>36 D</p>
--	-------------

25 - EQUIPMENTS AND FURNISHINGS

25-67 EMERGENCY FLOATATION GEAR

<p>25/67/00/000/000/010</p> <p>Cylinder</p> <p style="text-align: center;"><i>AMM 25-67-00, 6-2</i> <i>CMM 25.69.32</i></p> <p>Condition check. Check to be performed during the first assembly and to initiate from this one. GVI</p>	<p>0</p>
<p>25/67/00/000/000/100</p> <p>Bracket</p> <p style="text-align: center;"><i>AMM 25-67-00, 6-3</i></p> <p>Tropical and damp atmosphere Condition check. GVI</p>	<p>36 D</p>

Task Number Description/ Remarks	Documentation	Margin	Initial
-------------------------------------	---------------	--------	---------

26 - FIRE PROTECTION

26-22 CABIN EXTINGUISHER

<p>26/22/00/000/000/075</p> <p>Cabin fire extinguisher</p> <p align="right"><i>AMM 26-22-00, 6-1</i></p> <p>12085-01 (S262A10T1001)</p> <p>PLA863520-00 (T262M50T0002)</p> <p>Weighing.</p> <p>TSM</p> <p>WGH</p>	<p>36 D</p>		
--	-------------	--	--

34 - NAVIGATION

34-00 NAVIGATION

<p>34/00/00/000/000/030</p> <p>Stand-by horizon - Stand-by battery</p> <p align="right"><i>AMM 24-33-00, 5-2</i></p> <p>EE0033 A ou B.</p> <p>Check and charge the battery.</p> <p>FT</p>	<p>36 D</p>		
--	-------------	--	--

53 - FUSELAGE

53-50 AFT FUSELAGE

<p>53/50/00/000/000/310</p> <p>Tail boom</p> <p align="right"><i>AMM 53-50-00, 6-3</i> <i>AMM 53-50-00, 6-4</i></p> <p>Tropical and damp atmosphere</p> <p>Salt-laden atmosphere</p> <p>Check for corrosion under the antenna bases.</p> <p>DI</p>	<p>36 D</p>		
---	-------------	--	--

Mechanic	Date	Inspector	Date
Name :	Signature :	Stamp :	Signature :

End of the Document Unit

05-22-00**500 FH // 24 M**

D.U.	TITLE
ATA 05	TIME LIMITS/MTCE. CHKS
ATA 21	AIR CONDITIONING
ATA 23	COMMUNICATIONS
ATA 24	ELECTRICAL POWER
ATA 25	EQUIPMENTS AND FURNISHINGS
ATA 28	FUEL SYSTEM
ATA 29	HYDRAULIC POWER
ATA 31	INDICATING & RECORDING SYSTEMS
ATA 32	LANDING GEAR
ATA 33	LIGHTING SYSTEM
ATA 34	NAVIGATION
ATA 52	DOORS
ATA 53	FUSELAGE
ATA 55	STABILIZER
ATA 62	MAIN ROTOR
ATA 63	MAIN ROTOR DRIVE
ATA 65	TAIL ROTOR DRIVE
ATA 67	ROTORS FLIGHT CONTROLS
ATA 71	POWER PLANT
ATA 76	ENGINE CONTROLS
ATA 79	ENGINE OIL
ATA 88	ELECTRICAL HARNESSSES

Task Number Description/ Remarks	Documentation	Margin	Initial
-------------------------------------	---------------	--------	---------

05 - TIME LIMITS/MTCE. CHKS

05-22 PREPARATION FOR INSPECTION

<p>05/22/00/000/000/050</p> <p>Do a ground check</p> <p>GR</p>	<p><i>FLM Section 8</i></p>	<p><i>50 FH 73 D</i></p>	
---	-----------------------------	------------------------------	--

21 - AIR CONDITIONING

21-00 AIR CONDITIONING

<p>21/00/00/000/000/000</p> <p>P2 indicating system</p> <p>Very cold weather</p> <p>Functional test.</p> <p>FT</p>	<p><i>AMM 21-41-00, 5-1</i></p>	<p><i>50 FH 73 D</i></p>	
---	---------------------------------	------------------------------	--

<p>21/00/00/000/000/010</p> <p>P2 indicating system</p> <p>Check.</p> <p>GVI</p>	<p><i>AMM 21-21-00, 6-1</i></p>	<p><i>50 FH 73 D</i></p>	
---	---------------------------------	------------------------------	--

21-51 COOLING

<p>21/51/00/000/000/150</p> <p>Air conditioning system</p> <p>Inspection of the installation.</p> <p>DI</p>	<p><i>AMM 21-51-00, 6-1</i></p>	<p><i>50 FH 73 D</i></p>	
--	---------------------------------	------------------------------	--

<p>21/51/00/000/000/200</p> <p>Belt</p> <p>Check of tension.</p> <p>DI</p>	<p><i>AMM 21-51-00, 8-1</i></p>	<p><i>50 FH 73 D</i></p>	
---	---------------------------------	------------------------------	--

Task Number Description/ Remarks	Documentation	Margin	Initial
-------------------------------------	---------------	--------	---------

<p>21/51/00/000/000/250</p> <p>MGB compressor</p> <p>Tightening torque check of attachment. TCK</p>	<p><i>AMM 20-10-00, 6-1</i> <i>AMM 21-51-00, 8-1</i></p>	<p><i>50 FH</i> <i>73 D</i></p>	
--	--	-------------------------------------	--

23 - COMMUNICATIONS

23-00 COMMUNICATIONS

<p>23/00/00/000/000/050</p> <p>Communication system</p> <p>Inspection. VC</p>	<p><i>AMM 23-00-00, 6-1</i></p>	<p><i>50 FH</i> <i>73 D</i></p>	
--	---------------------------------	-------------------------------------	--

24 - ELECTRICAL POWER

24-00 ELECTRICAL POWER

<p>24/00/00/000/000/100</p> <p>Electrical power supply system</p> <p>Inspection. VC</p>	<p><i>AMM 24-00-00, 6-1</i></p>	<p><i>50 FH</i> <i>73 D</i></p>	
--	---------------------------------	-------------------------------------	--

24-33 BATTERY

<p>24/33/00/000/000/100</p> <p>Battery temperature detector</p> <p>Functional test. FT</p>	<p><i>AMM 24-33-00, 5-1</i></p>	<p><i>50 FH</i> <i>73 D</i></p>	
---	---------------------------------	-------------------------------------	--

Task Number Description/ Remarks	Documentation	Margin	Initial
-------------------------------------	---------------	--------	---------

25 - EQUIPMENTS AND FURNISHINGS

25-61 CABLE-CUTTER

<p>25/61/00/000/000/000</p> <p>Cable-cutter</p> <p>Inspection and check. VC</p>	<p><i>AMM 25-61-00, 6-1</i></p>	<p><i>50 FH 73 D</i></p>	
--	---------------------------------	------------------------------	--

25-63 EMERGENCY LOCATOR TRANSMITTER

<p>25/63/01/000/000/100</p> <p>Emergency locator transmitter</p> <p>JOLLIET JE2/JE2NG. Installation check. DI FT</p>	<p><i>AMM 25-63-01, 6-1</i></p>	<p><i>50 FH 73 D</i></p>	
<p>25/63/02/000/000/160</p> <p>Emergency locator transmitter</p> <p>ELT96A2560000000 (704A45737043)</p> <p>SOCATA. Installation check. DI FT</p>	<p><i>AMM 25-63-02, 6-1</i></p>	<p><i>50 FH 73 D</i></p>	

28 - FUEL SYSTEM

28-00 FUEL SYSTEM

<p>28/00/00/000/000/050</p> <p>Fuel system</p> <p>Condition check. GVI</p>	<p><i>AMM 28-00-00, 6-1</i></p>	<p><i>50 FH 73 D</i></p>	
---	---------------------------------	------------------------------	--

Task Number Description/ Remarks	Documentation	Margin	Initial
-------------------------------------	---------------	--------	---------

<p>28/00/00/000/000/060</p> <p>Strainers</p> <p>Check and cleaning. DI CLN</p>	<p><i>AMM 28-00-00, 6-3</i></p>	<p>50 FH 73 D</p>	
---	---------------------------------	-----------------------	--

28-22 DISTRIBUTION

<p>28/22/00/000/000/100</p> <p>Fuel shut-off valve</p> <p>Functional test. FT</p>	<p><i>AMM 28-22-00, 5-1</i></p>	<p>50 FH 73 D</p>	
--	---------------------------------	-----------------------	--

28-42 INDICATING

<p>28/42/00/000/000/150</p> <p>Fuel low-level warning</p> <p>Check. DI</p>	<p><i>AMM 28-42-00, 6-1</i></p>	<p>50 FH 73 D</p>	
---	---------------------------------	-----------------------	--

29 - HYDRAULIC POWER

29-00 HYDRAULIC POWER

<p>29/00/00/000/000/050</p> <p>Servocontrol - Accumulator</p> <p>Pressure check. NPT</p>	<p><i>AMM 29-00-00, 6-1</i></p>	<p>50 FH 73 D</p>	
---	---------------------------------	-----------------------	--

Task Number Description/ Remarks	Documentation	Margin	Initial
-------------------------------------	---------------	--------	---------

31 - INDICATING & RECORDING SYSTEMS

31-00 INDICATING AND RECORDING SYSTEMS

<p>31/00/00/000/000/050</p> <p>Indicating and recording system</p> <p>Check. GVI</p>	<p><i>AMM 31-00-00, 6-1</i></p>	<p><i>50 FH 73 D</i></p>	
---	---------------------------------	------------------------------	--

32 - LANDING GEAR

32-12 LANDING GEAR

<p>32/12/00/000/000/050</p> <p>Landing gear</p> <p>Detailed check. DI</p>	<p><i>AMM 32-12-00, 6-1</i></p>	<p><i>50 FH 73 D</i></p>	
--	---------------------------------	------------------------------	--

33 - LIGHTING SYSTEM

33-00 LIGHTING SYSTEMS

<p>33/00/00/000/000/050</p> <p>Lighting system</p> <p>Installation check. DI</p>	<p><i>AMM 33-00-00, 6-1</i></p>	<p><i>50 FH 73 D</i></p>	
---	---------------------------------	------------------------------	--

Task Number Description/ Remarks	Documentation	Margin	Initial
-------------------------------------	---------------	--------	---------

34 - NAVIGATION

34-00 NAVIGATION

<p>34/00/00/000/000/050</p> <p>Navigation system</p> <p>Installation check. DI</p>	<p><i>AMM 34-00-00, 6-1</i></p>	<p><i>50 FH</i> <i>73 D</i></p>	
---	---------------------------------	-------------------------------------	--

52 - DOORS

52-10 STANDARD CABIN DOORS

<p>52/10/00/000/000/000</p> <p>Standard cabin door</p> <p>Inspection/Check. GVI</p>	<p><i>AMM 52-10-00, 6-2</i> <i>AMM 52-10-00, 6-3</i> <i>AMM 52-10-00, 6-4</i></p>	<p><i>50 FH</i> <i>73 D</i></p>	
<p>52/10/00/000/000/100</p> <p>Standard cabin door</p> <p>Condition check. GVI</p>	<p><i>AMM 52-10-00, 6-1</i></p>	<p><i>50 FH</i> <i>73 D</i></p>	

52-11 RIGHT CABIN DOOR

<p>52/11/00/000/000/050</p> <p>Jettison system RH cabin door</p> <p>Functional test. FT</p>	<p><i>AMM 52-11-00, 5-1</i></p>	<p><i>50 FH</i> <i>73 D</i></p>	
--	---------------------------------	-------------------------------------	--

Task Number Description/ Remarks	Documentation	Margin	Initial
-------------------------------------	---------------	--------	---------

52-30 LOADING DOORS

<p>52/30/00/000/000/000</p> <p>Door lock</p> <p>HA2423-3 (706A31610026)</p> <p>Check and greasing. DI LUB</p>	<p>AMM 52-30-00, 3-1</p>	<p>50 FH 73 D</p>	
--	--------------------------	-----------------------	--

52-50 SLIDING DOOR

<p>52/50/00/000/000/200</p> <p>Cabin sliding door</p> <p>Condition check. GVI</p>	<p>AMM 52-50-00, 6-1</p>	<p>50 FH 73 D</p>	
<p>52/50/00/000/000/210</p> <p>Cabin sliding door</p> <p>Inspection/Check. DI</p>	<p>AMM 52-50-00, 6-2 AMM 52-50-00, 6-3</p>	<p>50 FH 73 D</p>	

52-53 LEFT SMALL DOOR

<p>52/53/00/000/000/000</p> <p>Jettison system LH small cabin door</p> <p>Functional test. FT</p>	<p>AMM 52-53-00, 5-1</p>	<p>50 FH 73 D</p>	
--	--------------------------	-----------------------	--

Task Number Description/ Remarks	Documentation	Margin	Initial
-------------------------------------	---------------	--------	---------

53 - FUSELAGE

53-00 FUSELAGE

<p>53/00/00/000/000/200</p> <p>Fuselage</p> <p>Visual check. GVI</p>	<p><i>AMM 53-00-00, 6-1</i> <i>AMM 53-00-00, 6-2</i></p>	<p><i>50 FH</i> <i>73 D</i></p>	
---	--	-------------------------------------	--

53-30 MAIN FUSELAGE

<p>53/30/00/000/000/300</p> <p>MGB suspension bar brackets</p> <p>Tightening torque check. TCK</p>	<p><i>AMM 20-10-00, 6-1</i> <i>AMM 53-30-00, 4-2</i></p>	<p><i>50 FH</i> <i>73 D</i></p>	
---	--	-------------------------------------	--

53-37 CABIN ANTIVIBRATORS

<p>53/37/00/000/000/000</p> <p>Cabin antivibrator support</p> <p>Readjustment of the tightening torque. RTQ</p>	<p><i>AMM 53-37-00, 6-1</i></p>	<p><i>50 FH</i> <i>73 D</i></p>	
--	---------------------------------	-------------------------------------	--

53-50 AFT FUSELAGE

<p>53/50/00/000/000/250</p> <p>Main fuselage and tail boom junction</p> <p>Tightening torque check. TCK</p>	<p><i>AMM 20-10-00, 6-1</i> <i>AMM 53-50-00, 4-1</i></p>	<p><i>50 FH</i> <i>73 D</i></p>	
--	--	-------------------------------------	--

Task Number Description/ Remarks	Documentation	Margin	Initial
-------------------------------------	---------------	--------	---------

53-53 FENESTRON

<p>53/53/00/000/000/150</p> <p>Tail boom and fenestron junction</p> <p>Tightening torque check. TCK</p>	<p><i>AMM 20-10-00, 6-1</i> <i>AMM 53-53-00, 4-1</i></p>	<p><i>50 FH</i> <i>73 D</i></p>	
--	--	-------------------------------------	--

55 - STABILIZER

55-11 HORIZONTAL STABILIZER

<p>55/11/00/000/000/000</p> <p>Horizontal stabilizer</p> <p>Detailed check. DI</p>	<p><i>AMM 55-11-00, 6-1</i></p>	<p><i>50 FH</i> <i>73 D</i></p>	
---	---------------------------------	-------------------------------------	--

62 - MAIN ROTOR

62-11 MAIN ROTOR BLADES

<p>62/11/00/000/000/150</p> <p>Main rotor blade</p> <p>Inspection. Check every 100 FH (marge 10 FH) for 500 FH, if a defect (inside the limits) is found : blade skin separation or blade leading edge stainless steel strip separation, cracks in the stainless steel leading edge. If no development is noted during this period, return to the normal inspection cycle. DI</p>	<p><i>AMM 62-11-00, 6-1</i></p>	<p><i>50 FH</i> <i>73 D</i></p>	
<p>62/11/00/000/000/160</p> <p>Attachment components</p> <p>Detailed check. DI</p>	<p><i>AMM 62-11-00, 6-4</i></p>	<p><i>50 FH</i> <i>73 D</i></p>	

Task Number Description/ Remarks	Documentation	Margin	Initial
-------------------------------------	---------------	--------	---------

62-21 MAIN ROTOR HUB

<p>62/21/00/000/000/780</p> <p>Contact area between rotor shaft and hub body</p> <p style="text-align: right;"><i>AMM 62-21-00, 6-2</i> <i>AMM 63-21-00, 6-2</i></p> <p>Check. DI</p>		<p><i>50 FH</i> <i>73 D</i></p>	
<p>62/21/00/000/000/790</p> <p>Main rotor hub</p> <p style="text-align: right;"><i>AMM 62-21-00, 6-2</i> <i>AMM 62-21-00, 6-3</i> <i>AMM 62-21-00, 6-4</i> <i>AMM 62-21-00, 6-5</i> <i>AMM 62-21-00, 6-6</i> <i>AMM 62-21-00, 6-7</i> <i>AMM 62-21-00, 6-8</i> <i>AMM 62-21-00, 6-9</i> <i>AMM 62-21-00, 6-10</i> <i>AMM 62-21-00, 6-11</i> <i>AMM 62-21-00, 6-12</i> <i>AMM 62-21-00, 6-13</i> <i>AMM 62-21-00, 6-14</i> <i>AMM 62-21-00, 6-15</i> <i>AMM 62-21-00, 6-16</i> <i>AMM 62-21-00, 6-17</i> <i>AMM 62-21-00, 6-18</i> <i>AMM 62-21-00, 6-19</i> <i>AMM 62-21-00, 6-20</i></p> <p>Visual check without removal. GVI</p>		<p><i>50 FH</i> <i>73 D</i></p>	
<p>62/21/00/000/000/795</p> <p>Split ring</p> <p style="text-align: right;"><i>AMM 62-21-00, 6-26</i></p> <p>Detailed check. DI</p>		<p><i>50 FH</i> <i>73 D</i></p>	
<p>62/21/00/000/000/840</p> <p>Scissors drive coupling / Main rotor hub</p> <p style="text-align: right;"><i>AMM 62-21-00, 6-28</i></p> <p>Tightening torque check. TCK</p>		<p><i>50 FH</i> <i>73 D</i></p>	

Task Number Description/ Remarks	Documentation	Margin	Initial
-------------------------------------	---------------	--------	---------

62-31 SWASHPLATE ASSEMBLY

<p>62/31/00/000/000/150</p> <p>Rotating swashplate</p> <p style="text-align: center;"><i>AMM 62-31-00, 6-6</i></p> <p>Inspection of free rotation.</p> <p>DI</p>		<p style="text-align: center;"><i>50 FH 73 D</i></p>	
<p>62/31/00/000/000/160</p> <p>Rotating swashplate</p> <p style="text-align: center;"><i>AMM 62-31-00, 6-6</i></p> <p>7050A3623019 (7050A3623019)</p> <p>Inspection of free rotation. Operation to be done every 100 FH (margin 10 FH) between 3300 FH and 5300 FH from the OTL.</p> <p>DI</p>		<p style="text-align: center;"><i>50 FH 73 D</i></p>	

62-32 FLARED HOUSING / SWASHPLATES / HUB COUPLINGS

<p>62/32/00/000/000/300</p> <p>Non-rotating and rotating scissors - Carbide rings</p> <p style="text-align: center;"><i>AMM 62-32-00, 3-1</i></p> <p>Greasing.</p> <p>LUB</p>		<p style="text-align: center;"><i>50 FH 73 D</i></p>	
<p>62/32/00/000/000/350</p> <p>"Diapason" scissors - Ball joint</p> <p style="text-align: center;"><i>AMM 62-32-00, 6-1</i></p> <p>Play check.</p> <p>DI</p>		<p style="text-align: center;"><i>50 FH 73 D</i></p>	
<p>62/32/00/000/000/360</p> <p>Scissor link</p> <p style="text-align: center;"><i>AMM 62-32-00, 6-2</i></p> <p>Check. In the case of default constated inside the rings of the scissor link (inside the limits) make sure of the absences of the following hard points CT 62-32-00, 6-7 every 100 FH (marge 10 FH).</p> <p>DI</p>		<p style="text-align: center;"><i>50 FH 73 D</i></p>	

Task Number Description/ Remarks	Documentation	Margin	Initial
-------------------------------------	---------------	--------	---------

62/32/00/000/000/370 Pitch change rod Detailed check. DI	AMM 62-32-00, 6-4	50 FH 73 D	
--	-------------------	---------------	--

62/32/00/000/000/400 Scissor bolt Play checks. DI	AMM 62-32-00, 6-5	50 FH 73 D	
---	-------------------	---------------	--

63 - MAIN ROTOR DRIVE

63-00 MAIN ROTOR DRIVE

63/00/00/000/000/300 Main rotor drive Condition check. GVI	AMM 63-00-00, 6-1	50 FH 73 D	
--	-------------------	---------------	--

63-11 MGB / ENGINE COUPLING

63/11/00/000/000/100 Ball joint bolt Tightening torque check. TCK	AMM 20-10-00, 6-1 AMM 63-11-00, 4-2	50 FH 73 D	
---	--	---------------	--

63/11/00/000/000/150 Flexible coupling Tightening torque check. TCK	AMM 20-10-00, 6-1 AMM 63-11-00, 6-6	50 FH 73 D	
---	--	---------------	--

Task Number Description/ Remarks	Documentation	Margin	Initial
-------------------------------------	---------------	--------	---------

63-22 MGB MAIN MODULE

<p>63/22/00/000/000/650</p> <p>MGB</p> <p>Drain and replace the MGB oil filter. DRN</p>	<p><i>AMM 12-10-00, 3-2</i> <i>AMM 63-22-00, 3-1</i></p>	<p><i>50 FH</i> <i>73 D</i></p>	
--	--	-------------------------------------	--

63-51 ROTOR BRAKE

<p>63/51/00/000/000/100</p> <p>Rotor brake</p> <p>Condition check. GVI</p>	<p><i>AMM 63-51-00, 6-1</i></p>	<p><i>50 FH</i> <i>73 D</i></p>	
---	---------------------------------	-------------------------------------	--

63-52 ROTOR BRAKE CONTROL

<p>63/52/00/000/000/050</p> <p>Rotor brake control</p> <p>Condition check. GVI</p>	<p><i>AMM 63-52-00, 6-1</i></p>	<p><i>50 FH</i> <i>73 D</i></p>	
---	---------------------------------	-------------------------------------	--

65 - TAIL ROTOR DRIVE

65-11 TAIL ROTOR DRIVE SHAFT

<p>65/11/00/000/000/800</p> <p>Damper and contact surface on drive shaft</p> <p>Check. DI</p>	<p><i>AMM 65-11-00, 6-3</i></p>	<p><i>50 FH</i> <i>73 D</i></p>	
--	---------------------------------	-------------------------------------	--

Task Number Description/ Remarks	Documentation	Margin	Initial
-------------------------------------	---------------	--------	---------

<p>65/11/00/000/000/900</p> <p>Flexible coupling attachment</p> <p>Detailed check. DI</p>	<p><i>AMM 65-11-00, 6-15</i></p>	<p><i>50 FH 73 D</i></p>	
--	----------------------------------	------------------------------	--

65-21 TAIL GEARBOX

<p>65/21/00/000/000/300</p> <p>TGB</p> <p>Oil change. DRN</p>	<p><i>AMM 12-10-00, 3-2</i></p>	<p><i>50 FH 73 D</i></p>	
--	---------------------------------	------------------------------	--

<p>65/21/00/000/000/350</p> <p>TGB / Stator coupling</p> <p>Tightening torque check. TCK</p>	<p><i>AMM 20-10-00, 6-1 AMM 65-21-00, 4-2</i></p>	<p><i>50 FH 73 D</i></p>	
---	---	------------------------------	--

<p>65/21/00/000/000/400</p> <p>TGB</p> <p>Condition check. GVI</p>	<p><i>AMM 65-21-00, 6-1</i></p>	<p><i>50 FH 73 D</i></p>	
---	---------------------------------	------------------------------	--

67 - ROTORS FLIGHT CONTROLS

67-10 MAIN ROTOR CONTROLS

<p>67/10/00/000/000/050</p> <p>Main rotor controls</p> <p>Condition check. GVI</p>	<p><i>AMM 67-10-00, 6-1</i></p>	<p><i>50 FH 73 D</i></p>	
---	---------------------------------	------------------------------	--

Task Number Description/ Remarks	Documentation	Margin	Initial
-------------------------------------	---------------	--------	---------

67-20 TAIL ROTOR CONTROLS

<p>67/20/00/000/000/100</p> <p>Tail rotor controls</p> <p>Condition check. GVI</p>	<p><i>AMM 67-20-00, 6-1</i></p>	<p><i>50 FH 73 D</i></p>	
---	---------------------------------	------------------------------	--

67-31 SERVOCONTROLS

<p>67/31/00/000/000/150</p> <p>Servocontrol</p> <p>Tightening torque check of the attachment bolts. TCK</p>	<p><i>AMM 20-10-00, 6-1 AMM 67-31-00, 4-2</i></p>	<p><i>50 FH 73 D</i></p>	
--	---	------------------------------	--

71 - POWER PLANT

71-00 POWER PLANT

<p>71/00/00/000/000/100</p> <p>Power plant installation</p> <p>Condition check. GVI</p>	<p><i>AMM 71-00-00, 6-1</i></p>	<p><i>50 FH 73 D</i></p>	
--	---------------------------------	------------------------------	--

Task Number Description/ Remarks	Documentation	Margin	Initial
-------------------------------------	---------------	--------	---------

71-41 ENGINE SUPPORT BRACKET

<p>71/41/00/000/000/200</p> <p>Engine support bracket components</p> <p style="padding-left: 40px;"> <i>AMM 71-41-00, 6-1</i> <i>AMM 71-41-00, 6-2</i> <i>AMM 71-41-00, 6-3</i> <i>AMM 71-41-00, 6-4</i> <i>AMM 71-41-00, 6-5</i> <i>AMM 71-41-00, 6-6</i> <i>AMM 71-41-00, 6-7</i> <i>AMM 71-41-00, 6-8</i> <i>AMM 71-41-00, 6-9</i> <i>AMM 71-41-00, 6-10</i> <i>AMM 71-41-00, 6-11</i> </p> <p>Detailed check. DI</p>		<p style="text-align: center;">50 FH 73 D</p>	
---	--	---	--

71-63 SAND FILTER

<p>71/63/00/000/000/150</p> <p>Sand filter - Electrical system</p> <p style="padding-left: 40px;"><i>AMM 71-63-00, 6-2</i></p> <p>Detailed check. DI</p>		<p style="text-align: center;">50 FH 73 D</p>	
---	--	---	--

76 - ENGINE CONTROLS

76-11 ANTICIPATOR BALL-TYPE CONTROL

<p>76/11/00/000/000/000</p> <p>Anticipator control - Ball joint</p> <p style="padding-left: 40px;"><i>AMM 76-11-00, 6-1</i></p> <p>Condition check. GVI</p>		<p style="text-align: center;">50 FH 73 D</p>	
--	--	---	--

Task Number Description/ Remarks	Documentation	Margin	Initial
-------------------------------------	---------------	--------	---------

76-12 MANUAL CONTROL

<p>76/12/00/000/000/000</p> <p>Ball end-fitting</p> <p>L'HOTELLIER. Check. DI</p>	<p><i>AMM 12-20-00, 6-1</i></p>	<p><i>50 FH 73 D</i></p>	
<p>76/12/00/000/000/050</p> <p>Fuel flow ball-type control</p> <p>Check. DI</p>	<p><i>AMM 76-12-00, 4-3</i></p>	<p><i>50 FH 73 D</i></p>	

79 - ENGINE OIL

79-21 ENGINE OIL COOLING

<p>79/21/00/000/000/050</p> <p>Oil cooling system</p> <p>Condition check. GVI</p>	<p><i>AMM 79-21-00, 6-1</i></p>	<p><i>50 FH 73 D</i></p>	
--	---------------------------------	------------------------------	--

88 - ELECTRICAL HARNESES

88-00 ELECTRICAL HARNESES

<p>88/00/00/000/000/050</p> <p>Electrical harnesses</p> <p>Check. GVI</p>	<p><i>AMM 88-00-00, 6-1</i></p>	<p><i>50 FH 73 D</i></p>	
--	---------------------------------	------------------------------	--

Mechanic	Date	Inspector	Date
Name :	Signature :	Stamp :	Signature :

Task Number Description/ Remarks	Documentation	Margin	Initial
-------------------------------------	---------------	--------	---------

End of the Document Unit

05-22-02**24 M**

D.U.	TITLE
ATA 24	ELECTRICAL POWER
ATA 34	NAVIGATION
ATA 53	FUSELAGE
ATA 62	MAIN ROTOR
ATA 63	MAIN ROTOR DRIVE

Task Number Description/ Remarks	Documentation	Margin	Initial
-------------------------------------	---------------	--------	---------

24 - ELECTRICAL POWER

24-33 BATTERY

<p>24/33/00/000/000/070</p> <p>Battery</p> <p style="text-align: right;"><i>CMM 24-33-96</i> <i>CHECK § 2.D</i> <i>CHECK § 2.E</i> <i>CHECK § 2.F</i></p> <p>150CH-1 (7050A4243027) 151CH-1 (7050A4243040) 151CH-2 (7050A4243039)</p> <p>Overhaul. DI</p>		73 D	
<p>24/33/00/000/000/080</p> <p>Battery</p> <p style="text-align: right;"><i>AMM 24-33-00, 3-1</i></p> <p>150CH-1 (7050A4243027) 151CH-1 (7050A4243040) 151CH-2 (7050A4243039)</p> <p>Battery compartment cleaning. CLN</p>		73 D	

34 - NAVIGATION

34-10 NAVIGATION ENVIRONNEMENT

<p>34/10/00/000/000/000</p> <p>Pitot-Static System</p> <p style="text-align: right;"><i>AMM 34-10-00, 3-1</i></p> <p>Bleeding and Drying. FT</p>		73 D	
---	--	------	--

Task Number Description/ Remarks	Documentation	Margin	Initial
-------------------------------------	---------------	--------	---------

53 - FUSELAGE

53-50 AFT FUSELAGE

<p>53/50/00/000/000/300</p> <p>Tail boom</p> <p style="text-align: center;"><i>AMM 53-50-00, 6-2</i> <i>AMM 53-50-00, 6-3</i> <i>AMM 53-50-00, 6-4</i></p> <p>Check for corrosion under the antenna bases.</p> <p>DI</p>		73 D	
---	--	------	--

62 - MAIN ROTOR

62-21 MAIN ROTOR HUB

<p>62/21/00/000/000/360</p> <p>Upper blade sleeve</p> <p style="text-align: center;"><i>AMM 62-21-00, 6-9</i></p> <p>Detailed check. Only concerns the aircraft before serial number 1498 and from 8001 to 8029 included not having applied SB 62-004 to the revision 1.</p> <p>DI</p>		73 D	
<p>62/21/00/000/000/410</p> <p>Lower blade sleeve</p> <p style="text-align: center;"><i>AMM 62-21-00, 6-10</i></p> <p>Detailed check. Only concerns the aircraft before serial number 1498 and from 8001 to 8029 included not having applied SB 62-004 to the revision 1.</p> <p>DI</p>		73 D	

63 - MAIN ROTOR DRIVE

63-22 MGB MAIN MODULE

<p>63/22/00/000/000/120</p> <p>Lower housing</p> <p style="text-align: center;"><i>AMM 63-22-00, 6-3</i></p> <p>Check of corrosion inside the bores of the tapered pin attaching cones of the MGB lower casing MP/N C632A2104102 or C632A2115101.</p> <p>GVI</p>		73 D	
---	--	------	--

Task Number Description/ Remarks	Documentation	Margin	Initial
---	----------------------	---------------	----------------

Mechanic	Date	Inspector	Date
Name :	Signature :	Stamp :	Signature :

End of the Document Unit

05-23-00**1500 FH // 72 M**

D.U.	TITLE
ATA 25	EQUIPMENTS AND FURNISHINGS
ATA 28	FUEL SYSTEM
ATA 29	HYDRAULIC POWER
ATA 62	MAIN ROTOR
ATA 65	TAIL ROTOR DRIVE

Task Number Description/ Remarks	Documentation	Margin	Initial
-------------------------------------	---------------	--------	---------

25 - EQUIPMENTS AND FURNISHINGS

25-21 CREW SEATS

25/21/00/000/000/020 Pilot and copilot seats Check. DI	AMM 25-21-00, 6-1	150 FH 180 D	
--	-------------------	-----------------	--

25-22 PASSENGERS SEATS

25/22/00/000/000/050 Aft bench seat Check. DI	AMM 25-22-00, 6-1	150 FH 180 D	
---	-------------------	-----------------	--

28 - FUEL SYSTEM

28-12 INTERNAL TANKS

28/12/00/000/000/200 Anti-spillage valve Check. DI	AMM 28-12-00, 6-2	150 FH 180 D	
--	-------------------	-----------------	--

29 - HYDRAULIC POWER

29-00 HYDRAULIC POWER

29/00/00/000/000/000 Hydraulic power system Draining. DRN	AMM 29-00-00, 3-2	150 FH 180 D	
---	-------------------	-----------------	--

Task Number Description/ Remarks	Documentation	Margin	Initial
-------------------------------------	---------------	--------	---------

62 - MAIN ROTOR

62-21 MAIN ROTOR HUB

<p>62/21/00/000/000/820</p> <p>Main rotor hub</p> <p style="text-align: center;"> <i>AMM 62-21-00, 6-2</i> <i>AMM 62-21-00, 6-3</i> <i>AMM 62-21-00, 6-4</i> <i>AMM 62-21-00, 6-5</i> <i>AMM 62-21-00, 6-6</i> <i>AMM 62-21-00, 6-7</i> <i>AMM 62-21-00, 6-8</i> <i>AMM 62-21-00, 6-9</i> <i>AMM 62-21-00, 6-10</i> <i>AMM 62-21-00, 6-11</i> <i>AMM 62-21-00, 6-12</i> <i>AMM 62-21-00, 6-13</i> <i>AMM 62-21-00, 6-14</i> <i>AMM 62-21-00, 6-15</i> <i>AMM 62-21-00, 6-16</i> <i>AMM 62-21-00, 6-17</i> <i>AMM 62-21-00, 6-18</i> <i>AMM 62-21-00, 6-19</i> <i>AMM 62-21-00, 6-20</i> <i>AMM 62-21-00, 6-21</i> <i>AMM 62-21-00, 6-22</i> <i>AMM 62-21-00, 6-23</i> <i>AMM 62-21-00, 6-24</i> <i>AMM 62-21-00, 6-25</i> </p> <p>Detailed check with removal. DI</p>		<p>150 FH 180 D</p>	
---	--	-------------------------	--

62-31 SWASHPLATE ASSEMBLY

<p>62/31/00/000/000/200</p> <p>Swashplate</p> <p style="text-align: center;"><i>AMM 62-31-00, 6-6</i></p> <p>Clearance check. DI</p>		<p>150 FH 180 D</p>	
---	--	-------------------------	--

Task Number Description/ Remarks	Documentation	Margin	Initial
-------------------------------------	---------------	--------	---------

65 - TAIL ROTOR DRIVE

65-11 TAIL ROTOR DRIVE SHAFT

<p>65/11/00/000/000/300</p> <p>Flexible coupling</p> <p>Detailed check. DI</p>	<p><i>AMM 65-11-00, 6-4</i></p>	<p>150 FH 180 D</p>	
<p>65/11/00/000/000/350</p> <p>Flexible coupling bolts</p> <p>Detailed check. DI</p>	<p><i>AMM 65-11-00, 6-5</i></p>	<p>150 FH 180 D</p>	
<p>65/11/00/000/000/400</p> <p>Splined flange</p> <p>Detailed check. DI</p>	<p><i>AMM 65-11-00, 6-7</i></p>	<p>150 FH 180 D</p>	
<p>65/11/00/000/000/450</p> <p>Bearing</p> <p>Detailed check. DI</p>	<p><i>AMM 65-11-00, 6-14</i></p>	<p>150 FH 180 D</p>	
<p>65/11/00/000/000/650</p> <p>Damper</p> <p>Adjustment check. RIG</p>	<p><i>AMM 65-11-00, 6-1</i></p>	<p>150 FH 180 D</p>	
<p>65/11/00/000/000/700</p> <p>Forward shaft</p> <p>Detailed check. DI</p>	<p><i>AMM 65-11-00, 6-2</i></p>	<p>150 FH 180 D</p>	

Task Number Description/ Remarks	Documentation	Margin	Initial
-------------------------------------	---------------	--------	---------

<p>65/11/00/000/000/710</p> <p>Rear shaft</p> <p>Detailed check. DI</p>	<p><i>AMM 65-11-00, 6-3</i></p>	<p><i>150 FH 180 D</i></p>	
--	---------------------------------	--------------------------------	--

<p>65/11/00/000/000/720</p> <p>Cover plate</p> <p>Detailed check. DI</p>	<p><i>AMM 65-11-00, 6-20</i></p>	<p><i>150 FH 180 D</i></p>	
---	----------------------------------	--------------------------------	--

Mechanic	Date	Inspector	Date
Name :	Signature :	Stamp :	Signature :

End of the Document Unit

05-23-02**72 M**

D.U.	TITLE
ATA 05	TIME LIMITS/MTCE. CHKS

Task Number	Documentation	Margin	Initial
Description/ Remarks			

05 - TIME LIMITS/MTCE. CHKS

05-40 DYNAMIC COMPONENTS CHECK

05/40/00/000/000/010 Dynamic systems <i>AMM 05-40-00, 6-1</i>	180 D
Detailed check. Operation to be carried out after having logged 144 M (margin 180 D) after initial setting to service or since the last Overhaul. DI	

Mechanic	Date	Inspector	Date
Name :	Signature :	Stamp :	Signature :

End of the Document Unit

05-24-02**144 M**

D.U.	TITLE
ATA 05	TIME LIMITS/MTCE. CHKS

Task Number Description/ Remarks	Documentation	<i>Margin</i>	Initial
--	----------------------	---------------	----------------

05 - TIME LIMITS/MTCE. CHKS

05-24 PREPARATION FOR THE MAJOR INSPECTION

<small>05/24/00/000/000/000</small> Preparation for the major inspection <p align="center"><i>AMM 05-24-00, 6-1</i></p> Detailed check. DI	<i>180 D</i>
--	--------------

Mechanic	Date	Inspector	Date
Name :	Signature :	Stamp :	Signature :

End of the Document Unit

05-25-00

D.U.	TITLE
ATA 05	TIME LIMITS/MTCE. CHKS
ATA 24	ELECTRICAL POWER
ATA 25	EQUIPMENTS AND FURNISHINGS
ATA 26	FIRE PROTECTION
ATA 28	FUEL SYSTEM
ATA 32	LANDING GEAR
ATA 53	FUSELAGE
ATA 62	MAIN ROTOR
ATA 64	TAIL ROTOR
ATA 65	TAIL ROTOR DRIVE

Task Number Description/ Remarks	Documentation	Interval	Margin	Initial
--	---------------	----------	--------	---------

05 - TIME LIMITS/MTCE. CHKS

05-40 DYNAMIC COMPONENTS CHECK

<p>05/40/00/000/000/000</p> <p>Dynamic systems</p> <p style="padding-left: 40px;"><i>AMM 05-40-00, 6-1</i></p> <p>Tropical and damp atmosphere Salt-laden atmosphere Sand-laden and/or dust-laden atmosphere</p> <p>Detailed check. Operation to be carried out after having logged 96 M (margin 180 D) after initial setting to service or since the last Overhaul.</p> <p>DI</p>		<p>48 M</p>	<p>146 D</p>	
---	--	--------------------	---------------------	--

24 - ELECTRICAL POWER

24-33 BATTERY

<p>24/33/00/000/000/050</p> <p>Battery</p> <p style="padding-left: 40px;"><i>CMM 24.33.96</i> <i>CHECK § 2.B</i></p> <p>151CH-2 (7050A4243039)</p> <p>Check. DI</p>		<p>6 M</p>	<p>18 D</p>	
<p>24/33/00/000/000/090</p> <p>Battery</p> <p style="padding-left: 40px;"><i>CMM 24.33.96</i> <i>CHECK § 2.B</i></p> <p>150CH-1 (7050A4243027) 151CH-1 (7050A4243040)</p> <p>Hot climatic conditions</p> <p>Check. DI</p>		<p>6 M</p>	<p>18 D</p>	

Task Number Description/ Remarks	Documentation	Interval	Margin	Initial
--	---------------	----------	--------	---------

24-36 STARTER/GENERATOR

<p>24/36/01/000/000/000</p> <p>Starter generator</p> <p><i>AMM 24-36-01, 6-1</i> <i>AMM 24-36-01, 6-2</i> <i>AMM 24-36-01, 6-4</i> <i>AMM 24-36-01, 6-5</i></p> <p>160SG140Q-1 (7050A4243037) 160SG140Q-1-XL (7050A4243050)</p> <p>SKURKA. Checking generator, brushes, damping system and splines. DI TCK</p>		<p>300 FH</p>	<p>30 FH</p>	
<p>24/36/02/000/000/050</p> <p>Starter generator</p> <p><i>AMM 24-36-02, 6-1</i> <i>AMM 24-36-02, 6-2</i> <i>AMM 24-36-02, 6-3</i></p> <p>524-061 (704A46101021)</p> <p>THALES. Checking generator, brushes and splines. DI TCK</p>		<p>600 FH</p>	<p>60 FH</p>	

25 - EQUIPMENTS AND FURNISHINGS

25-63 EMERGENCY LOCATOR TRANSMITTER

<p>25/63/01/000/000/090</p> <p>Emergency locator transmitter</p> <p><i>AMM 25-63-01, 5-1</i></p> <p>JOLLIET JE2/JE2NG. Functional test. FT</p>		<p>6 M</p>	<p>18 D</p>	
<p>25/63/02/000/000/100</p> <p>Emergency locator transmitter</p> <p><i>AMM 25-63-02, 5-1</i></p> <p>ELT96A2560000000 (704A45737043)</p> <p>SOCATA. Emergency locator transmitter self-test (3 consecutive phases). FT</p>		<p>6 M</p>	<p>18 D</p>	

Task Number Description/ Remarks	Documentation	Interval	Margin	Initial
--	---------------	----------	--------	---------

25/63/03/601/000/050				
Emergency locator transmitter				
	<i>AMM 25-63-03, 5-1</i>	1 M	3 D	
KANNAD 121 AF-H. KANNAD 406 AF-H. Self-test. FT				

25-67 EMERGENCY FLOATATION GEAR

25/67/00/000/000/020				
Cylinder				
		36 M	0	
		1 OPC	0	
215494-0	(7050A4256002)	//		
Proof test. 1 OPC = 1 utilization (ditching or untimely percussion of the inflation cylinder). To be returned to the manufacturer or to an approved workshop. Interval starting from the date of manufacture (TSM), then from the date of the last proof test. NPT				
25/67/00/000/000/030				
Cylinder				
		60 M	0	
		1 OPC	0	
215494-1	(7050A4256009)	//		
Proof test. 1 OPC = 1 utilization (ditching or untimely percussion of the inflation cylinder). To be returned to the manufacturer or to an approved workshop. Interval starting from the date of manufacture (TSM), then from the date of the last proof test. NPT				
25/67/00/000/000/110				
Bracket				
	<i>AMM 25-67-00, 6-3</i>	18 M	54 D	
Condition check. GVI				
25/67/00/000/000/300				
Float				
	<i>AMM 25-67-00, 6-4</i>	18 M	54 D	
	<i>CMM 25.69.32</i>			
Condition check. GVI				

Task Number Description/ Remarks	Documentation	Interval	Margin	Initial
25/67/00/000/000/305 Float PRE ASB 25A026 Detailed check. DI	<i>AMM 25-67-00, 6-4</i>	300 FH	0	
25/67/00/000/000/310 Cover assembly Check. TSM DI	<i>AMM 25-67-00, 6-4</i>	18 M	54 D	
25/67/00/000/000/350 Emergency floatation gear frangible discs Test. Check to be performed on and from initial installation. FT	<i>AMM 25-67-00, 5-2</i>	// 500 FH 12 M	50 FH 36 D	
25/67/00/000/000/360 Emergency floatation gear Check and functional test. FT GVI	<i>AMM 25-67-00, 5-1 AMM 25-67-00, 6-6</i>	// 500 FH 18 M	50 FH 54 D	

25-91 CARGO SLING

25/91/00/000/000/100 Cargo sling system Check. DI	<i>AMM 25-91-00, 6-1</i>	// 24 M 500 SC	73 D 50 SC	
---	--------------------------	---------------------------	-----------------------	--

Task Number Description/ Remarks	Documentation	Interval	Margin	Initial
--	---------------	----------	--------	---------

26 - FIRE PROTECTION

26-22 CABIN EXTINGUISHER

26/22/00/000/000/150 Cabin fire extinguisher H1-10AIR Condition check. GVI	AMM 26-22-00, 6-1 (704A32810008)	6 M	18 D	
---	-------------------------------------	-----	------	--

28 - FUEL SYSTEM

28-11 STORAGE

28/11/00/000/000/000 Fuel tank Tropical and damp atmosphere Control and maintenance by preventive fungicidal treatment of circuits and fuel tanks. DI	MTC 20.08.06.401	3 M	9 D	
--	------------------	-----	-----	--

32 - LANDING GEAR

32-17 SKIS

32/17/00/000/000/030 Ski Condition check. GVI	AMM 32-17-00, 6-1	25 FH	2 FH	
---	-------------------	-------	------	--

Task Number Description/ Remarks	Documentation	Interval	Margin	Initial
--	---------------	----------	--------	---------

53 - FUSELAGE

53-00 FUSELAGE

<p>53/00/00/000/000/040</p> <p>Structure</p> <p style="padding-left: 40px;"><i>AMM 12-20-00, 3-1</i></p> <p>Salt-laden atmosphere</p> <p>Washing.</p> <p>CLN</p>		<p>7 D</p>	<p>0</p>	
---	--	-------------------	-----------------	--

62 - MAIN ROTOR

62-11 MAIN ROTOR BLADES

<p>62/11/00/000/000/200</p> <p>Main rotor blade</p> <p style="padding-left: 40px;"><i>AMM 62-11-00, 6-1</i></p> <p>Sand-laden and/or dust-laden atmosphere</p> <p>Visual check.</p> <p>DI CLN</p>		<p>25 FH</p>	<p>2 FH</p>	
--	--	---------------------	--------------------	--

62-21 MAIN ROTOR HUB

<p>62/21/00/000/000/000</p> <p>Droop restrainer ring</p> <p style="padding-left: 40px;"><i>AMM 62-21-00, 4-2</i></p> <p>Tropical and damp atmosphere</p> <p>Salt-laden atmosphere</p> <p>Sand-laden and/or dust-laden atmosphere</p> <p>Greasing.</p> <p>LUB</p>	<p>//</p>	<p>100 FH 3 M</p>	<p>10 FH 9 D</p>	
<p>62/21/00/000/000/010</p> <p>Anti-vibrator</p> <p style="padding-left: 40px;"><i>AMM 62-21-00, 3-1</i></p> <p>Tropical and damp atmosphere</p> <p>Salt-laden atmosphere</p> <p>Sand-laden and/or dust-laden atmosphere</p> <p>Greasing.</p> <p>LUB</p>	<p>//</p>	<p>100 FH 3 M</p>	<p>10 FH 9 D</p>	

Task Number Description/ Remarks	Documentation	Interval	Margin	Initial
--	---------------	----------	--------	---------

62-31 SWASHPLATE ASSEMBLY

62/31/00/000/000/020				
Swashplate	<i>AMM 62-31-00, 3-1</i>	100 FH	10 FH	
		// 3 M	9 D	
Tropical and damp atmosphere Salt-laden atmosphere Sand-laden and/or dust-laden atmosphere Greasing. LUB				

64 - TAIL ROTOR

64-21 TAIL ROTOR HUB

64/21/00/000/000/255				
Hub body assembly	<i>AMM 64-21-00, 6-4</i>	1000 FH	100 FH	
		// 24 M	73 D	
Detailed check. DI				
64/21/00/000/000/260				
Splined flange	<i>AMM 64-21-00, 6-5</i>	1000 FH	100 FH	
		// 24 M	73 D	
Detailed check. DI				
64/21/00/000/000/270				
Outer bearing	<i>AMM 64-21-00, 6-6</i>	1000 FH	100 FH	
		// 24 M	73 D	
Detailed check. DI				
64/21/00/000/000/280				
Inner bearing	<i>AMM 64-21-00, 6-7</i>	1000 FH	100 FH	
		// 24 M	73 D	
Detailed check. DI				

Task Number Description/ Remarks	Documentation	Interval	Margin	Initial
64/21/00/000/000/290 Torsion spider assembly Detailed check. DI	AMM 64-21-00, 6-8	// 1000 FH 24 M	100 FH 73 D	
64/21/00/000/000/300 Blade assembly Detailed check. DI	AMM 64-21-00, 6-9	// 1000 FH 24 M	100 FH 73 D	
64/21/00/000/000/310 Stepped bolt Detailed check. DI	AMM 64-21-00, 6-10	// 1000 FH 24 M	100 FH 73 D	
64/21/00/000/000/320 Top chinese bushing Detailed check. DI	AMM 64-21-00, 6-11	// 1000 FH 24 M	100 FH 73 D	
64/21/00/000/000/330 Bottom chinese bushing Detailed check. DI	AMM 64-21-00, 6-12	// 1000 FH 24 M	100 FH 73 D	
64/21/00/000/000/340 Pitch-change spider Detailed check. DI	AMM 64-21-00, 6-13	// 1000 FH 24 M	100 FH 73 D	

Task Number Description/ Remarks	Documentation	Interval	Margin	Initial
64/21/00/000/000/350 Fairing assembly Detailed check. DI	<i>AMM 64-21-00, 6-14</i>	// 1000 FH 24 M	100 FH 73 D	
64/21/00/000/000/360 Hub plate Detailed check. DI	<i>AMM 64-21-00, 6-15</i>	// 1000 FH 24 M	100 FH 73 D	
64/21/00/000/000/370 Thrust washer / Thrust nut / Lockwasher Detailed check. DI	<i>AMM 64-21-00, 6-16</i>	// 1000 FH 24 M	100 FH 73 D	

65 - TAIL ROTOR DRIVE

65-11 TAIL ROTOR DRIVE SHAFT

65/11/00/000/000/760 Bearing Tropical and damp atmosphere Salt-laden atmosphere Sand-laden and/or dust-laden atmosphere Greasing. LUB	<i>AMM 65-11-00, 3-1</i>	// 100 FH 3 M	10 FH 9 D	
--	--------------------------	------------------	--------------	--

Mechanic	Date	Inspector	Date
Name :	Signature :	Stamp :	Signature :

End of the Document Unit

05-26-00

D.U.	TITLE
ATA 24	ELECTRICAL POWER
ATA 25	EQUIPMENTS AND FURNISHINGS
ATA 28	FUEL SYSTEM
ATA 53	FUSELAGE
ATA 62	MAIN ROTOR
ATA 63	MAIN ROTOR DRIVE
ATA 64	TAIL ROTOR
ATA 65	TAIL ROTOR DRIVE
ATA 67	ROTORS FLIGHT CONTROLS

Task Number Description/ Remarks	Documentation	Interval	Margin	Initial
--	---------------	----------	--------	---------

24 - ELECTRICAL POWER

24-36 STARTER/GENERATOR

24/36/01/000/000/550

<p>Starter generator</p> <p>AMM 24-36-01, 6-1 AMM 24-36-01, 6-3 AMM 24-36-01, 6-5</p> <p>160SG140Q-4 (7050A4243054)</p> <p>SKURKA. After the introduction to service of a new or overhauled component. Checking generator, commutator, brushes and splines.</p> <p>DI</p>		PO	300 FH	30 FH
--	--	----	--------	-------

25 - EQUIPMENTS AND FURNISHINGS

25-67 EMERGENCY FLOATATION GEAR

25/67/00/000/000/400

<p>Float</p> <p>AMM 25-67-00, 6-5 CMM 25.69.32</p> <p>Detailed and proof pressure check. Interval starting from the date of manufacture.</p> <p>NPT</p>		PO & &	72 M 108 M 144 M	180 D 180 D 180 D
--	--	--------------	------------------------	-------------------------

28 - FUEL SYSTEM

28-00 FUEL SYSTEM

28/00/00/000/000/250

<p>Strainers</p> <p>AMM 28-00-00, 6-3</p> <p>Each time after the component is installed. Check and cleaning.</p> <p>DI CLN</p>		PO &	10 FH 100 FH	1 FH 10 FH
---	--	---------	-----------------	---------------

Task Number Description/ Remarks	Documentation	Interval	Margin	Initial
--	---------------	----------	--------	---------

53 - FUSELAGE

53-37 CABIN ANTIVIBRATORS

53/37/00/000/000/010				
Cabin antivibrator support	<i>AMM 53-37-00, 6-1</i>	PO	2 FH	8 FH
Each time after the component is installed.				
Readjustment of the tightening torque of attachment screws.				
RTQ				

62 - MAIN ROTOR

62-00 MAIN ROTOR

62/00/00/000/000/750				
Main rotor	<i>AMM 20-10-00, 6-1</i> <i>AMM 62-00-00, 6-2</i>	PO	2 FH	8 FH
Each time after the component is installed.				
Tightening torque check after maintenance work.				
TCK				

62-11 MAIN ROTOR BLADES

62/11/00/000/000/180				
Main rotor blade	<i>AMM 62-11-00, 6-1</i>	PO &	100 FH 200 FH	10 FH 20 FH
After the introduction to service of a new, overhauled or repaired component.				
Inspection.				
GVI				

62-21 MAIN ROTOR HUB

62/21/00/000/000/850				
Mast - scissors drive coupling	<i>AMM 62-21-00, 6-28</i>	PO	2 FH	8 FH
Each time after the component is installed.				
Readjustment of the tightening torque.				
RTQ				

Task Number Description/ Remarks	Documentation	Interval	Margin	Initial
--	---------------	----------	--------	---------

63 - MAIN ROTOR DRIVE

63-00 MAIN ROTOR DRIVE

<p>63/00/00/000/000/600</p> <p>Main rotor drive</p> <p><i>AMM 20-10-00, 6-1</i> <i>AMM 63-00-00, 6-3</i></p> <p>Each time after the component is installed.</p> <p>Tightening torque check.</p> <p>TCK</p>		<p>PO</p> <p>2 FH</p>	<p>8 FH</p>	
---	--	-----------------------	-------------	--

63-22 MGB MAIN MODULE

<p>63/22/00/000/000/640</p> <p>MGB</p> <p><i>AMM 12-10-00, 3-2</i> <i>AMM 63-22-00, 3-1</i></p> <p>After the introduction to service of a new, overhauled or repaired component.</p> <p>Drain and replace the MGB oil filter.</p> <p>DRN</p>		<p>PO</p> <p>30 FH</p>	<p>5 FH</p>	
---	--	------------------------	-------------	--

64 - TAIL ROTOR

64-21 TAIL ROTOR HUB

<p>64/21/00/000/000/000</p> <p>Tail rotor</p> <p><i>AMM 20-10-00, 6-1</i> <i>AMM 64-21-00, 6-3</i></p> <p>Each time after the component is installed.</p> <p>Tightening torque check.</p> <p>TCK</p>		<p>PO</p> <p>2 FH</p>	<p>8 FH</p>	
---	--	-----------------------	-------------	--

Task Number Description/ Remarks	Documentation	Interval	Margin	Initial
--	---------------	----------	--------	---------

65 - TAIL ROTOR DRIVE

65-21 TAIL GEARBOX

65/21/00/000/000/500 TGB After the introduction to service of a new, overhauled or repaired component. Draining. DRN	AMM 12-10-00, 3-2	PO	30 FH	5 FH
---	-------------------	----	-------	------

67 - ROTORS FLIGHT CONTROLS

67-31 SERVOCONTROLS

67/31/00/000/000/200 Servocontrol Each time after the component is installed. Readjustment of the tightening torque of servocontrol attachment bolts. RTQ	AMM 20-10-00, 3-2 AMM 67-31-00, 4-2	PO	2 FH	8 FH
--	--	----	------	------

Mechanic	Date	Inspector	Date
Name :	Signature :	Stamp :	Signature :

End of the Document Unit

