

---

---

**SERVICE BULLETIN**

**N° 139-705**

**DATE:** May 11, 2023

**REV. :** /

---

---

**TITLE**

**ATA 34 - KIT EGPWS -034 INSTALLATION**

**REVISION LOG**

First Issue

---

An appropriate entry should be made in the aircraft log book upon accomplishment.  
If ownership of aircraft has changed, please, forward to new owner.

---

## **1. PLANNING INFORMATION**

### **A. EFFECTIVITY**

All AW139 helicopters from S/N 31400 to S/N 31699, from S/N 31700 onwards, from S/N 41300 to S/N 41499 and from S/N 41500 onwards.

### **B. COMPLIANCE**

At Customer's option.

### **C. CONCURRENT REQUIREMENTS**

N.A.

### **D. REASON**

This Service Bulletin is issued in order to provide the necessary instructions to perform the installation of the kit EGPWS -034 P/N 4G3440F00311.

### **E. DESCRIPTION**

Leonardo Helicopters has developed this Service Bulletin in order to install the kit EGPWS -034 P/N 4G3440F00311.

Part I of this Service Bulletin provides the necessary information to perform the installation of the EGPWS complete provision P/N 3G3440A01111, that includes the structural provision P/N 3G5310A04513 which performs the installation of supports, and the electrical provision P/N 3G3440A00713, which performs the installation and the connection of seven cable assemblies.

Part II provides the necessary information to perform the EGPWS equipment installation P/N 3G3440A01311, which consists of a display controller, a mounting tray and a computer.

### **F. APPROVAL**

The technical content of this Service Bulletin is approved under the authority of DOA nr. EASA.21.J.005. For helicopters registered under other Aviation Authorities, before applying the Service Bulletin, applicable Aviation Authority approval must be checked within Leonardo Helicopters customer portal.

EASA states mandatory compliance with inspections, modifications or technical directives and related time of compliance by means of relevant Airworthiness Directives. If an aircraft listed in the effectivity embodies a modification or repair not LHD certified and affecting the content of this Service Bulletin, it is responsibility of the Owner/Operator to obtain a formal approval by Aviation Authority having jurisdiction on

the aircraft, for any adaptation necessary before incorporation of the present Service Bulletin.

## G. MANPOWER

To comply with this Service Bulletin, the following MMH are deemed necessary:

Part I: approximately forty (40) MMH

Part II: approximately sixteen (16) MMH

MMH are based on hands-on time and can change with personnel and facilities available.

## H. WEIGHT AND BALANCE

### PART I

WEIGHT (kg)	ARM (mm)	MOMENT (kgmm)
		3.25
LONGITUDINAL BALANCE	4581	14888.3
LATERAL BALANCE	280	910

### PART II

WEIGHT (kg)	ARM (mm)	MOMENT (kgmm)
		3.87
LONGITUDINAL BALANCE	7278	28165.9
LATERAL BALANCE	246	952

## I. REFERENCES

### 1) PUBLICATIONS

Following Data Modules refer to AMP:

<u>DATA MODULE</u>	<u>DESCRIPTION</u>	<u>PART</u>
DM01 39-A-00-20-00-00A-120A-A	Helicopter on ground for a safe maintenance	I, II
DM02 39-A-06-41-00-00A-010A-A	Access doors and panels - General data	I, II
DM03 39-A-11-00-01-00A-520A-A	Decal - remove procedure	I, II
DM04 39-A-11-00-01-00A-720A-A	Decal - install procedure	I, II
DM05 39-A-24-91-04-00A-920A-K	Integrally lighted panel - replacement	I
DM06 39-A-20-10-08-00A-622A-A	Electrical contacts - crimp	I
DM07 39-A-34-43-03-00A-720A-K	EGPWS configuration module - install procedure	I

<u>DATA MODULE</u>	<u>DESCRIPTION</u>	<u>PART</u>
DM08 39-A-34-43-02-00A-720A-K	EGPWS computer mounting tray install procedure	II
DM09 39-A-34-43-01-00A-720A-K	EGPWS computer install procedure	II
DM10 39-B-31-61-09-00A-720A-A	Number 1 display controller install procedure	II
DM11 39-B-31-61-10-00A-720A-A	Number 2 display controller install procedure	II
DM12 39-A-46-20-00-00A-750A-A	Processing and integrating - Options and setting file - Load software procedure	II
DM13 39-B-31-61-00-00A-320B-A	Central display system - Display controllers - Operation test	II
DM14 39-C-34-43-00-00A-320A-K	Enhanced ground proximity warning system operation test	II

## 2) ACRONYMS & ABBREVIATIONS

AMDI	Aircraft Material Data Information
AMP	Aircraft Maintenance Publication
AUX	Auxiliary
CB	Circuit Breaker
DM	Data Module
DOA	Design Organization Approval
EASA	European Aviation Safety Agency
EGPWS	Enhanced Ground Proximity Warning System
IPD	Illustrated Part Data
ITEP	Illustrated Tool and Equipment Publication
LH	Left Hand
LHD	Leonardo Helicopters Division
MMH	Maintenance Man Hours
NVG	Night Vision Goggles
O/H	Overhead
P/N	Part Number
RH	Right Hand
SB	Service Bulletin
S/N	Serial Number

## 3) ANNEX

N.A.

## **J. PUBLICATIONS AFFECTED**

N.A.

## **K. SOFTWARE ACCOMPLISHMENT SUMMARY**

Software to be updated:

Primus Epic Option File

Option File P/N is depending upon helicopter configuration that can be different from the one reported in relevant helicopter "Commessa di Vendita". Customer must contact Product Support Engineering ([engineering.support.lhd@leonardo.com](mailto:engineering.support.lhd@leonardo.com)) to request the correct Option File at least three months in advance from the scheduled embodiment of this Service Bulletin.

## 2. MATERIAL INFORMATION

### A. REQUIRED MATERIALS

#### 1) PARTS

##### PART I

#	P/N	ALTERNATIVE P/N	DESCRIPTION	Q.TY	LVL	NOTE	LOG P/N
1	4G3440F00311		KIT EGPWS - 34	REF	.		-
2	3G3440A01111		EGPWS COMPLETE PROVISION	REF	..		-
3	3G5310A04513		EGPWS STRUCTURAL PROVISION	REF	...		-
4	3G5315A28031		LH support assy	1	....		139-705L1
5	3G5315A28131		RH support assy	1	....		139-705L1
6	3G5315A28451		LH joint	1	....		139-705L1
7	3G5315A28551		RH joint	1	....		139-705L1
8	3G5315A29151		Panel	1	....		139-705L1
9	3G5315A19551	3G5315A19551A1	Bracket	1	....		139-705L1
10	AGS4719-407	NAS1720H4L2A	Rivet	2	....		139-705L1
11	AGS4719-508	NAS1720H5L2A	Rivet	48	....		139-705L1
12	MS20426AD3-7		Rivet	0.1 kg	....		139-705L1
13	MS21075L06	MS21075L06N	Nut plate	4	....		139-705L1
14	NAS1097AD4-5		Rivet	0.1 kg	....		139-705L1
15	NAS1836-3-13		Insert	2	....		139-705L1
16	MS27039-1-06		Screw	2	....		139-705L1
17	NAS1149D0332K		Washer	2	....		139-705L1
18	3G3440A00713		EGPWS ELECTRICAL PROVISION	REF	...		-
19	3G9A01A26321	3G3440A00713A1R	EGPWS C/A (A1A263)	1	....		139-705L1
20	3G9A02A25021		EGPWS C/A (A2A250)	1	....		139-705L1
21	3G9A01B27421	3G3440A00713A2R	EGPWS C/A (A1B274)	1	....		139-705L1
22	3G9A02B25021		EGPWS C/A (A2B250)	1	....		139-705L1
23	3G9B01B55221	3G3440A00713A3R	EGPWS C/A (B1B552)	1	....		139-705L1
24	3G9B02B23821		EGPWS C/A (B2B238)	1	....		139-705L1
25	3G9C01B22521		EGPWS C/A (C1B225)	1	....		139-705L1
26	3G9C02B22321	3G3440A00713A4R	EGPWS C/A (C2B223)	1	....		139-705L1
27	3G9C02B24221		EGPWS C/A (C2B242)	1	....		139-705L1
28	700-1710-001		Configuration module	1	....	(1)	-
29	A366A3E12C		Stud	1	....		139-705L1
30	A388A3E08C		Stud	1	....		139-705L1
31	AW001CB02H		Clamp	2	....		139-705L1
32	AW001CB04H		Clamp	3	....		139-705L1
33	AW001CB06H		Clamp	2	....		139-705L1
34	AW001CL001-N6		Support	2	....		139-705L1
35	AW001TL3A08		Anchor nut	1	....		139-705L1
36	DCC-12		Protective cap	1	....		139-705L1
37	DCC-15		Protective cap	2	....		139-705L1
38	ED300J380		Decal	1	....		139-705L1
39	MS21042L3	NAS9926-3L	Nut	1	....		139-705L1
40	NAS1149D0332J		Washer	3	....		139-705L1
41	A590A02		Ferrule	1	....		139-705L1
42	NAS1190E3P6AK		Screw	1	....		139-705L1
43	NAS1801-3-10		Screw	1	....		139-705L1

#	P/N	ALTERNATIVE P/N	DESCRIPTION	Q.TY	LVL	NOTE	LOG P/N
44	SK3000-2-S879	SK3000-2	Cover	1	....		139-705L1
45	MS3320-3		Circuit breaker	1	....		139-705L1
46	ED300CB171		Decal	1	....		139-705L1
47	A556A-T20		Electrical wire	2.5 m	....		139-705L1
48	MS25036-149		Electrical contact	1	....		139-705L1
49	M39029/56-351		Electrical contact	5	....		139-705L1
50	3G2490LXXXXX		Integrally lit auxiliary C/B panel	1	....	(4)	-
51	M39029/56-348		Electrical contact	41	....		139-705L1
52	M39029/57-354		Electrical contact	22	....		139-705L1
53	M39029/57-357		Electrical contact	4	....		139-705L1
54	M39029/58-360		Electrical contact	34	....		139-705L1
55	M39029/58-363		Electrical contact	6	....		139-705L1
56	A523A-A05		Electrical contact	9	....		139-705L1
57	001104-100-02	A523A-A01	Electrical contact	1	....		139-705L1
58	001104-202-02	A523A-A05	Electrical contact	8	....		139-705L1
59	M23053/8-004-C		Insulation sleeving	10 m	....		139-705L1
60	M23053/8-005-C		Insulation sleeving	10 m	....		139-705L1

## **PART II**

#	P/N	ALTERNATIVE P/N	DESCRIPTION	Q.TY	LVL	NOTE	LOG P/N
61	4G3440F00311		KIT EGPWS - 34	REF	.		-
62	3G3440A01311		EGPWS -034 EQUIPMENT INSTALLATION	REF	..		-
63	405-0383-001		MK XXII EGPWS mounting tray	1	...	(1)	-
64	7016683-966	7016683-866	Display controller	2	...	(6)	-
65	965-1595-034		EGPWS computer	1	...		139-705L2
66	ED300A106		Decal	1	...		139-705L2
67	MS24693-S30		Screw	2	...		139-705L2
68	MS35206-230		Screw	2	...		139-705L2
69	Primus Epic Option File		S/W	1	.	(5)	-

Refer also to IPD for the spares materials required to comply with the AMP DMs referenced in the accomplishment instructions.

## **2) CONSUMABLES**

The following consumable materials, or equivalent, are necessary to accomplish this Service Bulletin:

#	SPEC./LHD CODE NUMBER	DESCRIPTION	Q.TY	NOTE	PART
70	EN6049-006-25-5 or A582A25	Nomex	1 m	(2)	I, II
71	A236A02AB	Edging	AR	(2)	I, II
72	AW001CK03LC	Lacing cord	AR	(2) (3)	I
73	900004953	Tape	AR	(2)	I
74	199-05-002, Type 2, Class II	Adhesive EA934NA (C397)	AR	(2)	I

Refer also to AMDI for the consumable materials required to comply with the AMP DM referenced in the accomplishment instructions.

### 3) LOGISTIC MATRIX

In order to apply this Service Bulletin, the following Logistic P/N can be ordered in accordance with the applicable notes:

LOGISTIC P/N	Q.TY (PER HELO)	NOTE	PART
139-705L1	1		
700-1710-001	1	(1)	Part I
3G2490LXXXXX	1	(4)	
139-705L2	1		
405-0383-001	1	(1)	Part II
7016683-966 or 7016683-866	2	(6)	
Primus Epic Option File	1	(5)	

#### NOTE

- (1) If Part I and Part II are both accomplished, EGPWS Mounting Tray and Configuration Module will be supplied as Installation Kit P/N 755-7013-007.
- (2) Item to be procured as local supply.
- (3) Lacing cord AW001CK03LC may be used as alternative to tape 900004953.
- (4) The P/N is not properly completed because it is depending on the helicopter configuration. Customers must contact Product Support Engineering ([engineering.support.lhd@leonardo.com](mailto:engineering.support.lhd@leonardo.com)) to request the new auxiliary CB panel at least three months in advance from the scheduled application of this Service Bulletin.
- (5) Refer to software accomplishment summary paragraph.
- (6) The Display controller NVG P/N 7016683-866 is the NVG-version and may be used as alternative to the Display controller P/N 7016683-966 (non-NVG version).

#### B. SPECIAL TOOLS

Refer to ITEP for the special tools required to comply with the AMP DM referenced in the accomplishment instructions.

#### C. INDUSTRY SUPPORT INFORMATION

Customization.



### **3. ACCOMPLISHMENT INSTRUCTIONS**

#### **GENERAL NOTES**

- a) Place an identification tag on all components that are re-usable, including the attaching hardware that has been removed to gain access to the modification area and adequately protect them until their later re-use.
- b) Shape the cables in order to prevent interference with the structure and the other existing installations, using where necessary suitable lacing cords and plastic cable tiedown.
- c) Exercise extreme care during drilling operations to prevent instruments, cables and hoses damage.
- d) After drilling, remove all swarf and sharp edges. Apply on bare metal a light film of primer unless the hole is used for ground connection.
- e) During the installation of bonding braids or components requiring grounding, clean the surface structure in order to obtain a good ground contact.
- f) Let adhesive cure at room temperature for at least 24 hours unless otherwise specified.
- g) All lengths are in mm.

#### **PART I**

1. In accordance with AMP DM 39-A-00-20-00-00A-120A-A prepare the helicopter on ground for a safe maintenance. Disconnect the battery, all electrical power sources and/or the external power supply.
2. In accordance with AMP DM 39-A-06-41-00-00A-010A-A and with reference to Figures 1 thru 8, and to Figure 11 thru Figure 17, remove all external panels, internal panels and internal liners as required to gain access to the area affected by the installation and perform EGPWS complete provision P/N 3G3440A01111 as described in the following procedure:
  - 2.1 With reference to Figure 1 and Figure 2, perform EGPWS structural provision P/N 3G5310A04513 as described in the following procedure:
    - 2.1.1 With reference to Figure 1 View B and Detail C, temporarily locate the RH support assy P/N 3G5315A28131, the LH support assy

P/N 3G5315A28031, the RH joint P/N 3G5315A28551 and the LH joint P/N 3G5315A28451 on the lower frame STA 7200 P/N 3P5340A10453 and countermark n°48 rivet holes positions.

- 2.1.2 With reference to Figure 1 View B and Detail C, drill n°48 rivet holes in the previously marked positions thru the lower frame STA 7200 P/N 3P5340A10453. Prepare the surface to assure a good ground contact.
- 2.1.3 With reference to Figure 1 Detail C, remove the existing rivets from the indicated positions of the angle STA 7200 P/N 3P5340A13152 and install the rivets P/N NAS1097AD4-5.
- 2.1.4 With reference to Figure 1 View B and Detail C, install the RH support assy P/N 3G5315A28131, the LH support assy P/N 3G5315A28031, the RH joint P/N 3G5315A28551 and the LH joint P/N 3G5315A28451 on the lower frame STA 7200 P/N 3P5340A10453 by means of n°48 rivets P/N AGS4719-508.
- 2.1.5 With reference to Figure 1 View D-D, drill n°1 rivet hole thru the LH joint P/N 3G5315A28451 and LH support assy P/N 3G5315A28031 and n°1 rivet hole thru the RH joint P/N 3G5315A28551 RH support assy P/N 3G5315A28131 in accordance with the dimensioning shown.
- 2.1.6 With reference to Figure 1 View D-D, fix the RH joint P/N 3G5315A28551 to the RH support assy P/N 3G5315A28131, and the LH joint P/N 3G5315A28451 to the LH support assy P/N 3G5315A28031, by means of n°2 rivets P/N AGS4719-407.
- 2.1.7 With reference to Figure 1 View E, temporarily locate the panel P/N 3G5315A29151 on the RH support assy P/N 3G5315A28131 and the LH support assy P/N 3G5315A28031, then countermark n°8 rivet holes positions.
- 2.1.8 With reference to Figure 1 View E, drill n°8 rivet holes in the previously marked positions thru the RH support assy P/N 3G5315A28131 and the LH support assy P/N 3G5315A28031. Prepare the surfaces to assure a good ground contact.
- 2.1.9 With reference to Figure 1 View E, install the panel P/N 3G5315A29151 on the RH support assy P/N 3G5315A28131 and the LH support assy P/N 3G5315A28031 by means of n°8 rivets P/N NAS1097AD4-5.
- 2.1.10 With reference to Figure 1 View E and Section F-F, drill n°4 holes  $\varnothing 4.52 \div 4.65$  thru the panel P/N 3G5315A29151, the RH support assy P/N 3G5315A28131 and the LH support assy P/N 3G5315A28031 in

- accordance with the dimensioning shown. Prepare the surfaces to assure a good ground contact.
- 2.1.11 With reference to Figure 1 Section F-F, install n°4 nut plates P/N MS21075L06 on the panel P/N 3G5315A29151 by means of n°8 rivets P/N MS20426AD3-7.
  - 2.1.12 With reference to Figure 2 Section G-G and Section H-H, drill n°2 holes  $\varnothing 11.48 \div 11.61$  thru the panel assy RH upper P/N 3G5315A49131.
  - 2.1.13 With reference to Figure 2 Section G-G and Section H-H, install n°2 inserts P/N NAS1836-3-13 on the panel assy RH upper P/N 3G5315A49131 by means of the adhesive EA934NA (C397).
  - 2.1.14 With reference to Figure 2 Section G-G and Section H-H, install the bracket P/N 3G5315A19551 by means of n°2 washers P/N NAS1149D0332K and n°2 screws P/N MS27039-1-06.
- 2.2 With reference to Figure 3 thru Figure 8, and to Figure 11 thru 17, perform EGPWS electrical provision P/N 3G3440A00713 as described in the following procedure:
- 2.2.1 With reference to Figure 7 View looking rear area RH side, remove the screw P/N MS35207-262, the washer P/N NAS1149D0332J, and the bracket P/N A426A01V110A.
  - 2.2.2 In accordance with AMP DM 39-A-11-00-01-00A-520A-A, and with reference to Figure 7 View looking rear area RH side, remove the data decal P/N ED300GPW.
  - 2.2.3 With reference to Figure 7 View looking rear area RH side, install the dust cover P/N SK3000-2-S879.
  - 2.2.4 In accordance with AMP DM 39-A-11-00-01-00A-720A-A, and with reference to Figure 7 View looking rear area RH side, install the decal P/N ED300J380.
  - 2.2.5 With reference to Figure 7 View looking rear area RH side, install in the location number 1 the stud P/N A366A3E12C.
  - 2.2.6 With reference to Figure 8 Detail C, install in the location n°3 the stud P/N A388A3E08C.
  - 2.2.7 With reference to Figure 8 Detail C, install in the locations n°4 and n°5 the n°2 supports P/N AW001CL001-N6.
  - 2.2.8 With reference to Figure 8 View B-B, install in the location n°2 the anchor nut P/N AW001TL3A08.

**NOTE**

Customer must contact LHD engineering.support.lhd@leonardo.com at least 3 months in advance of embodiment date of this Service Bulletin in order to collect the exact W/D applicable to helicopter configuration.

- 2.2.9 With reference to AMP DM 39-A-24-91-04-00A-920A-K, remove from the Overhead CB panel the existing Integrally lit panel and install the new integrally lit panel P/N 3G2490LXXXXX.
- 2.2.10 Install n°1 circuit breaker P/N MS3320-3 in the position indicated as EGPWS on the new integrally lit panel P/N 3G2490LXXXXX.
- 2.2.11 In accordance with AMP DM 39-A-11-00-01-00A-720A-A, apply the decal P/N ED300CB171 in the adjacent area.
- 2.2.12 Route one piece of electrical wire P/N A556A-T20 of adequate length between the circuit breaker CB171 and the overhead circuit breaker panel connector PL1J4.
- 2.2.13 Perform the electrical connection of the previously routed wire between the circuit breaker CB171 pin 2 and the overhead circuit breaker panel connector PL1J4 pin S, respectively by means of one terminal lug P/N MS25036-149 and one electrical contact P/N M39029/56-351.
- 2.2.14 Connect the circuit breaker CB171 to the 28V DC Main Bus 2 W22B.
- 2.2.15 Perform a pin-to-pin continuity check of all the electrical connections made.

**NOTE**

Use the edging P/N A236A on the edges which are liable to cause damage to the cable assemblies or where abrasion may occur.

**NOTE**

Install the tubing braided P/N A582A as a protection against chafing where contact with the structure may occur. The tubing protection is not a substitute for good routing practice.

- 2.2.16 With reference to Figure 3 thru Figure 8, lay down the following cable assemblies on the existing routes unless otherwise indicated on the figures:
  - 3G9A01A26321 EGPWS C/A (A1A263)

- 3G9A02A25021 EGPWS C/A (A2A250)
  - 3G9A01B27421 EGPWS C/A (A1B274)
  - 3G9A02B25021 EGPWS C/A (A2B250)
  - 3G9B01B55221 EGPWS C/A (B1B552)
  - 3G9B02B23821 EGPWS C/A (B2B238)
  - 3G9C01B22521 EGPWS C/A (C1B225)
  - 3G9C02B22321 EGPWS C/A (C2B223)
  - 3G9C02B24221 EGPWS C/A (C2B242)
- 2.2.17 With reference to Figure 3 thru Figure 8, secure the cable assemblies lay down at the previous step by means of existing hardware and lacing cords.
- 2.2.18 With reference to Figure 7 View looking rear area RH side, install the clamp P/N AW001CB04H on the C/A C2B242 by means of washer P/N NAS1149D0332J and nut P/N MS21042L3.
- 2.2.19 With reference to Figure 7 View looking rear area RH side, install in the indicated positions n°2 clamps P/N AW001CB02H on the C/A C2B242 by means of the existing hardware.
- 2.2.20 With reference to Figure 8 Detail C, install the clamp P/N AW001CB04H and the clamp P/N AW001CB06H on the C/A C1B225, the C/A C2B223 and on the C/A C2B242 by means of n°1 washer P/N NAS1149D0332J and n°1 screw P/N NAS1190E3P6AK.
- 2.2.21 With reference to Figure 8 View B-B, install the clamp P/N AW001CB04H and the clamp P/N AW001CB06H on the C/A C1B225, the C/A C2B223 and on the C/A C2B242 by means of n°1 washer P/N NAS1149D0332J and n°1 screw P/N NAS1801-3-10.
- 2.2.22 In accordance with AMP DM 39-A-34-43-03-00A-720A-K and with reference to Figure 8 Detail F, install the EGPWS configuration module P/N 700-1710-001.
- 2.2.23 With reference to Figure 8 Detail F replace the backshell of connector A106P2 with the connector backshell supplied within the EGPWS configuration module P/N 700-1710-001.
- 2.2.24 With reference to Figure 8 Detail F and Detail G, connect the wire P/N A556A-T24 to the shield chain A106P2 by means of n°1 ferrule P/N A590A02.
- 2.2.25 In accordance with AMP DM 39-A-20-10-08-00A-622A-A and with reference to Figure 4 View looking down RH side, and Figures 13 and

- 14 Wiring Diagram, perform the electrical connections between the connector A2-3P1 and the module TB116-3.
- 2.2.26 In accordance with AMP DM 39-A-20-10-08-00A-622A-A and with reference to Figure 4 View looking down RH side, and Figures 13 and 14 Wiring Diagram, perform the electrical connections between the connector P101 and the module TB116-3.
- 2.2.27 In accordance with AMP DM 39-A-20-10-08-00A-622A-A and with reference to Figure 4 View looking down RH side, Figure 6 View A-A, and Figures 13 and 14 Wiring Diagram, perform the electrical connections between the connector P106 and the junction module TB116-1.
- 2.2.28 In accordance with AMP DM 39-A-20-10-08-00A-622A-A and with reference to Figure 5 View looking instrument panel back RH side A.D.O.F., Figure 6 View A-A, and Figure 17 Wiring Diagram, perform the electrical connections between the connector P106 and the junction module TB150-1.
- 2.2.29 In accordance with AMP DM 39-A-20-10-08-00A-622A-A and with reference to Figure 4 View looking down RH side, and Figures 13 and 14 Wiring Diagram, perform the electrical connections between the connector TB116-1 and the junction module TB106P1.
- 2.2.30 In accordance with AMP DM 39-A-20-10-08-00A-622A-A and with reference to Figure 4 View looking down LH side, Figure 5 View looking instrument panel back RH side A.D.O.F., and Figures 11 and 12 Wiring Diagram, perform the electrical connections between the connector A1-3P2 and the connector J113.
- 2.2.31 In accordance with AMP DM 39-A-20-10-08-00A-622A-A and with reference to Figure 5 View looking instrument panel back RH side A.D.O.F., and Figures 15 and 16 Wiring Diagram, perform the electrical connections between the connector J113, the connector A95P1 and the connector A31P1.
- 2.2.32 In accordance with AMP DM 39-A-20-10-08-00A-622A-A and with reference to Figure 5 View looking instrument panel back RH side A.D.O.F., Figure 6 View looking STA 1070 to STA 3120, and Figures 11 and 12 Wiring Diagram, perform the electrical connections between the connector PL8P2 and the connector J113.
- 2.2.33 In accordance with AMP DM 39-A-20-10-08-00A-622A-A and with reference to Figure 4 View looking down RH side, Figure 6 View A-A,

- and Figures 11 and 12 Wiring Diagram, perform the electrical connections between the connector A2-3P2 and the connector P110.
- 2.2.34 In accordance with AMP DM 39-A-20-10-08-00A-622A-A and with reference to Figure 5 View looking instrument panel back RH side A.D.O.F., Figure 6 View A-A, and Figures 11 and 12 Wiring Diagram, perform the electrical connections between the connector P113 and the connector P110.
- 2.2.35 In accordance with AMP DM 39-A-20-10-08-00A-622A-A and with reference to Figure 5 View looking instrument panel back RH side A.D.O.F., Figure 6 View A-A, and Figures 15 and 16 Wiring Diagram, perform the electrical connections between the connector A30P1, the connector A42P1, the connector P113 and the connector P110.
- 2.2.36 In accordance with AMP DM 39-A-20-10-08-00A-622A-A and with reference to Figure 4 View looking down RH side, Figure 6 View looking STA 1070 to STA 3120, and Figures 11 and 12 Wiring Diagram, perform the electrical connections between the connector PL24P2 and the junction TB106P1.
- 2.2.37 In accordance with AMP DM 39-A-20-10-08-00A-622A-A and with reference to Figure 4 View looking down RH side, Figure 6 View A-A, and Figures 11 and 12 Wiring Diagram, perform the electrical connections between the connector P110 and the junction TB106P1.
- 2.2.38 In accordance with AMP DM 39-A-20-10-08-00A-622A-A and with reference to Figure 4 View looking down RH side, Figure 5 View looking instrument panel back RH side A.D.O.F., and Figures 11 and 12 Wiring Diagram, perform the electrical connections between the connector P113 and the junction TB106P1.
- 2.2.39 In accordance with AMP DM 39-A-20-10-08-00A-622A-A and with reference to Figure 6 view looking under floor RH side, Figure 7 view looking rear area RH side, and Figures 13, 14 and 17 Wiring Diagram, perform the electrical connections between the connector J106 and the connector J202.
- 2.2.40 In accordance with AMP DM 39-A-20-10-08-00A-622A-A and with reference to Figure 7 view looking rear area RH side, and Figure 17 Wiring Diagram, perform the electrical connections between the module TB2240 and the connector J202.
- 2.2.41 In accordance with AMP DM 39-A-20-10-08-00A-622A-A and with reference to Figure 6 View looking STA 1070 to STA 3120, Figure 7 view

- looking rear area RH side, and Figures 11 and 12 Wiring Diagram, perform the electrical connections between the connector PL1P4 and the connector J202.
- 2.2.42 In accordance with AMP DM 39-A-20-10-08-00A-622A-A and with reference to Figure 6 view looking under floor RH side, Figure 7 view looking rear area RH side, and Figures 11, 12, 15 and 16 Wiring Diagram, perform the electrical connections between the connector J110 and the connector J208.
- 2.2.43 In accordance with AMP DM 39-A-20-10-08-00A-622A-A and with reference to Figure 7 view looking rear area RH side, and Figure 8 Detail C and Figures 13 and 14 Wiring Diagram, perform the electrical connections between the DC power ground TB306, the ground module TB310 and the connector A106P1.
- 2.2.44 In accordance with AMP DM 39-A-20-10-08-00A-622A-A and with reference to Figure 7 view looking rear area RH side, and Figure 8 Detail C and Figure 13 thru 16 Wiring Diagram, perform the electrical connections between the connector P208 and the connector A106P1.
- 2.2.45 In accordance with AMP DM 39-A-20-10-08-00A-622A-A and with reference to Figure 7 view looking rear area RH side, and Figure 8 Detail C and Figures 13 and 14 Wiring Diagram, perform the electrical connections between the connector P208 and the connector A106P2.
- 2.2.46 In accordance with AMP DM 39-A-20-10-08-00A-622A-A and with reference to Figure 7 view looking rear area RH side, and Figure 8 Detail C and Figures 17 Wiring Diagram, perform the electrical connections between the DC power ground TB350 and the connector A106P3.
- 2.2.47 With reference to Figure 4 View looking down RH side and Figure 13 Wiring Diagram, perform the electrical connection of the connector A1-3P1 to the modular avionic unit A1, and the connector J101 to the connector P101.
- 2.2.48 Perform a pin-to-pin continuity check of all the electrical connections made.



### NOTE

Do NOT perform the following steps 2.2.49 and 2.2.50 if Part II of this Service Bulletin is accomplished immediately after Part I.

- 2.2.49 With reference to Figure 8 Detail C and Figure 7 Detail D, protect and stow the connectors A106P1 and A106P2 of the C/A C1B225 and C2B223 by means of n°2 protective caps P/N DCC-15, the tape P/N 900004953 and the Nomex protections P/N A582A25.
- 2.2.50 With reference to Figure 8 Detail C and Figure 7 Detail E, protect and stow the connector A106P3 of the C/A C2B242 by means of n°1 protective cap P/N DCC-12, the tape P/N 900004953 and the Nomex protection P/N A582A25.
- 3. In accordance with AMP DM 39-A-06-41-00-00A-010A-A re-install all external panels, internal panels and liners previously removed.
- 4. In accordance with weight and balance changes, update the Chart A (see Rotorcraft Flight Manual, Part II, section 6).
- 5. Return the helicopter to flight configuration and record for compliance with Part I of this Service Bulletin on the helicopter logbook.
- 6. Gain access to My Communications section on Leonardo WebPortal and compile the "Service Bulletin Application Communication".

As an alternative, send the attached compliance form to the following mail box:

[engineering.support.lhd@leonardo.com](mailto:engineering.support.lhd@leonardo.com)

and (for North, Central and South America) also to:

[AWPC.Engineering.Support@leonardocompany.us](mailto:AWPC.Engineering.Support@leonardocompany.us)

## **PART II**

1. In accordance with AMP DM 39-A-00-20-00-00A-120A-A, prepare the helicopter on ground for a safe maintenance. Disconnect the battery, all electrical power sources and/or the external power supply.
2. In accordance with AMP DM 39-A-06-41-00-00A-010A-A and with reference to Figure 9 and Figure 10, remove all external panels, internal panels and internal liners as required to gain access to the area affected by the installation and perform the EGPWS -034 equipment installation P/N 3G3440A01311 as described in the following procedure:
  - 2.1 In accordance with AMP DM 39-A-34-43-02-00A-720A-K, and with reference to Figure 9 and Figure 10 View A, install the MK XXII EGPWS computer mounting tray P/N 405-0383-001, by means of n°2 screws P/N MS35206-230 and n°2 screws MS24693-S30.

### **NOTE**

Use the edging P/N A236A on edges which are liable to cause damage to cable assemblies or where abrasion may occur.

### **NOTE**

Install the tubing braided P/N A582A as a protection against chafing where contact with the structure may occur. The tubing protection is not a substitute for good routing practice.

- 2.2 In accordance with AMP DM 39-A-34-43-01-00A-720A-K, and with reference to Figure 9 and Figure 10 View A, install the EGPWS computer P/N 965-1595-034 (A106).
- 2.3 In accordance with AMP DM 39-A-11-00-01-00A-720A-A, and with reference to Figure 10 View A, install the decal P/N ED300A106 on the EGPWS computer P/N 965-1595-034.

### **NOTE**

Perform the following steps 2.4 and 2.5 only if Part II is NOT accomplished immediately after Part I of this SB.

- 2.4 With reference to Figure 7 and Figure 10 Detail D, remove the n°2 protective caps P/N DCC-15, the tape P/N 900004953 and the Nomex protections P/N A582A25 from the connectors A106P1 and A106P2.
- 2.5 With reference to Figure 7 and Figure 10 Detail D, remove the protective cap P/N DCC-12, the tape P/N 900004953 and the Nomex protection P/N A582A25 from the connector A106P3.

- 2.6 In accordance with AMP DM 39-B-31-61-09-00A-720A-A and AMP DM 39-B-31-61-10-00A-720A-A, and with reference to Figure 9 and Figure 10 View B, install the display controllers P/N 7016683-966 (or P/N 7016683-866).
- 2.7 With reference to Figure 10 View C, remove the lockout ring P/N Y30700501 from the EGPWS circuit breaker located on the AUX O/H panel.

**NOTE**

Customer must contact AW139 Product Support Engineering [engineering.support.lhd@leonardo.com](mailto:engineering.support.lhd@leonardo.com) to request the correct Option File at least three months in advance from the scheduled application of this Service Bulletin.

- 2.8 In accordance with AMP DM 39-A-46-20-00-00A-750A-A, ensure that the applicable Option File has been installed for the S/W kit installation.
- 2.9 In accordance with applicable steps of AMP DM 39-B-31-61-00-00A-320B-A, perform the operation test of the display controllers P/N 7016683-966 (or P/N 7016683-866).
- 2.10 In accordance with AMP DM 39-C-34-43-00-00A-320A-K, perform the operation test of the kit EGPWS-034 P/N 4G3440F00311.
3. In accordance with AMP DM 39-A-06-41-00-00A-010A-A re-install all external panels, internal panels and liners previously removed.
4. In accordance with weight and balance changes, update the Chart A (see Rotorcraft Flight Manual, Part II, section 6).
5. Return the helicopter to flight configuration and record for compliance with Part II of this Service Bulletin on the helicopter logbook.
6. Gain access to My Communications section on Leonardo WebPortal and compile the "Service Bulletin Application Communication".

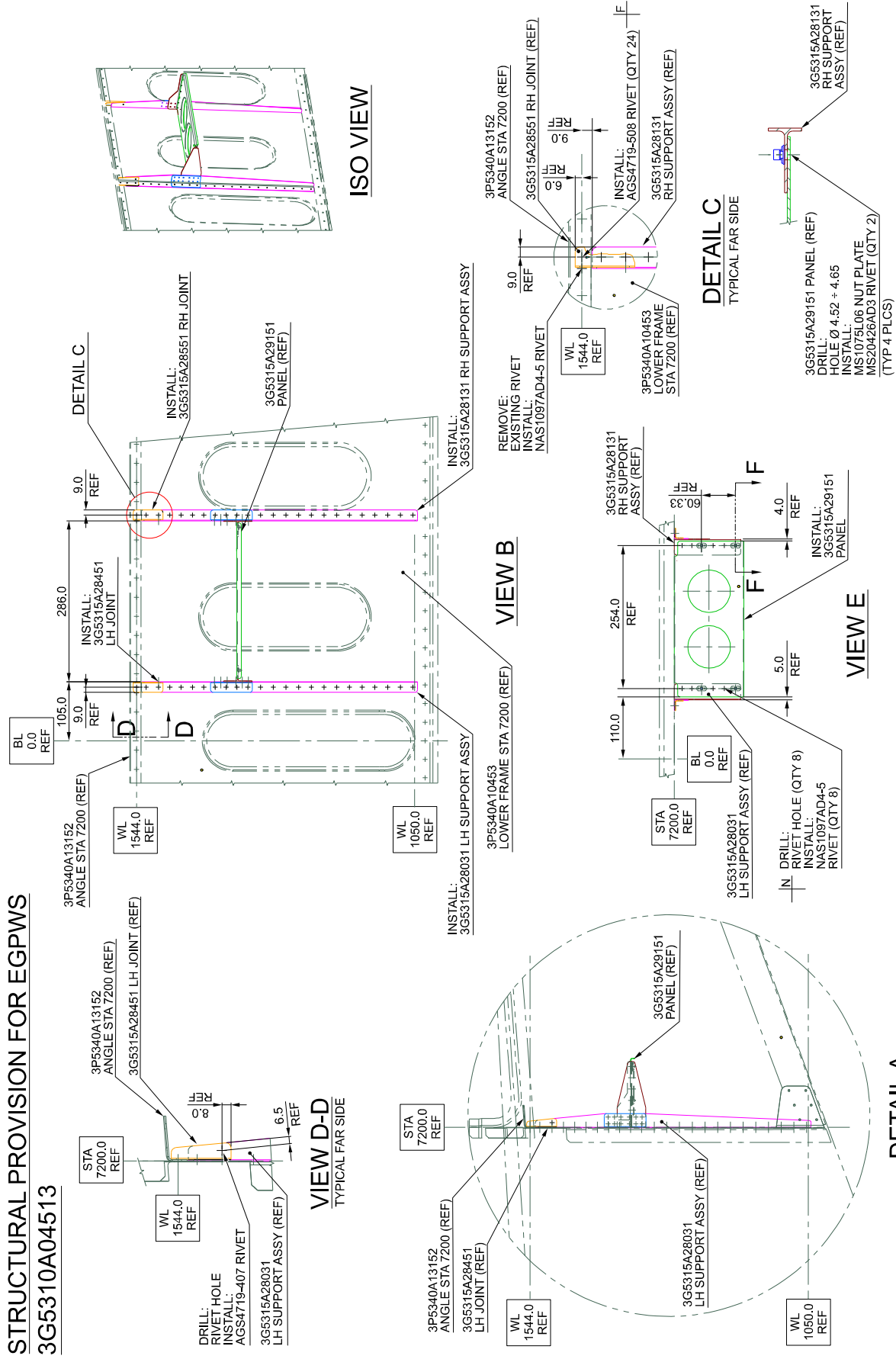
As an alternative, send the attached compliance form to the following mail box:

[engineering.support.lhd@leonardo.com](mailto:engineering.support.lhd@leonardo.com)

and (for North, Central and South America) also to:

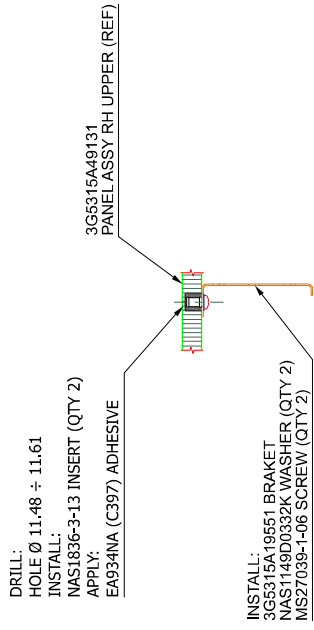
[AWPC.Engineering.Support@leonardocompany.us](mailto:AWPC.Engineering.Support@leonardocompany.us)

**STRUCTURAL PROVISION FOR EGPWS**  
**3G5310A04513**

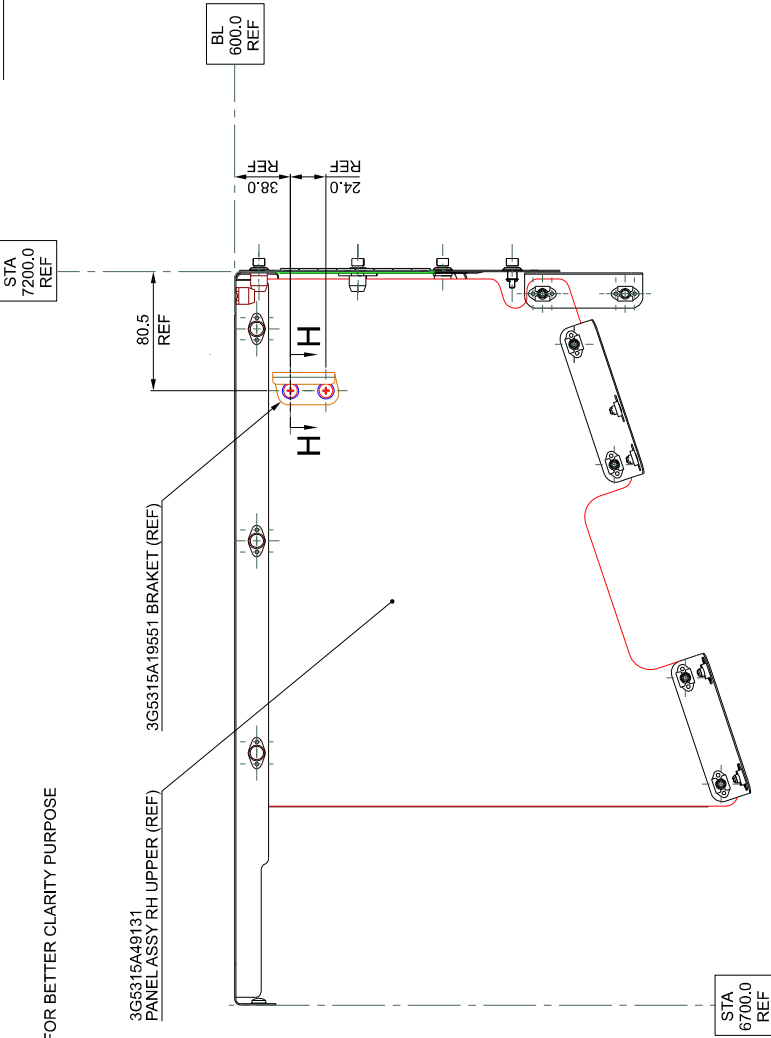
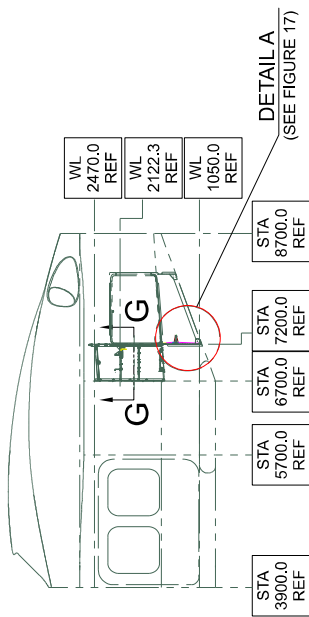


**Figure 1**

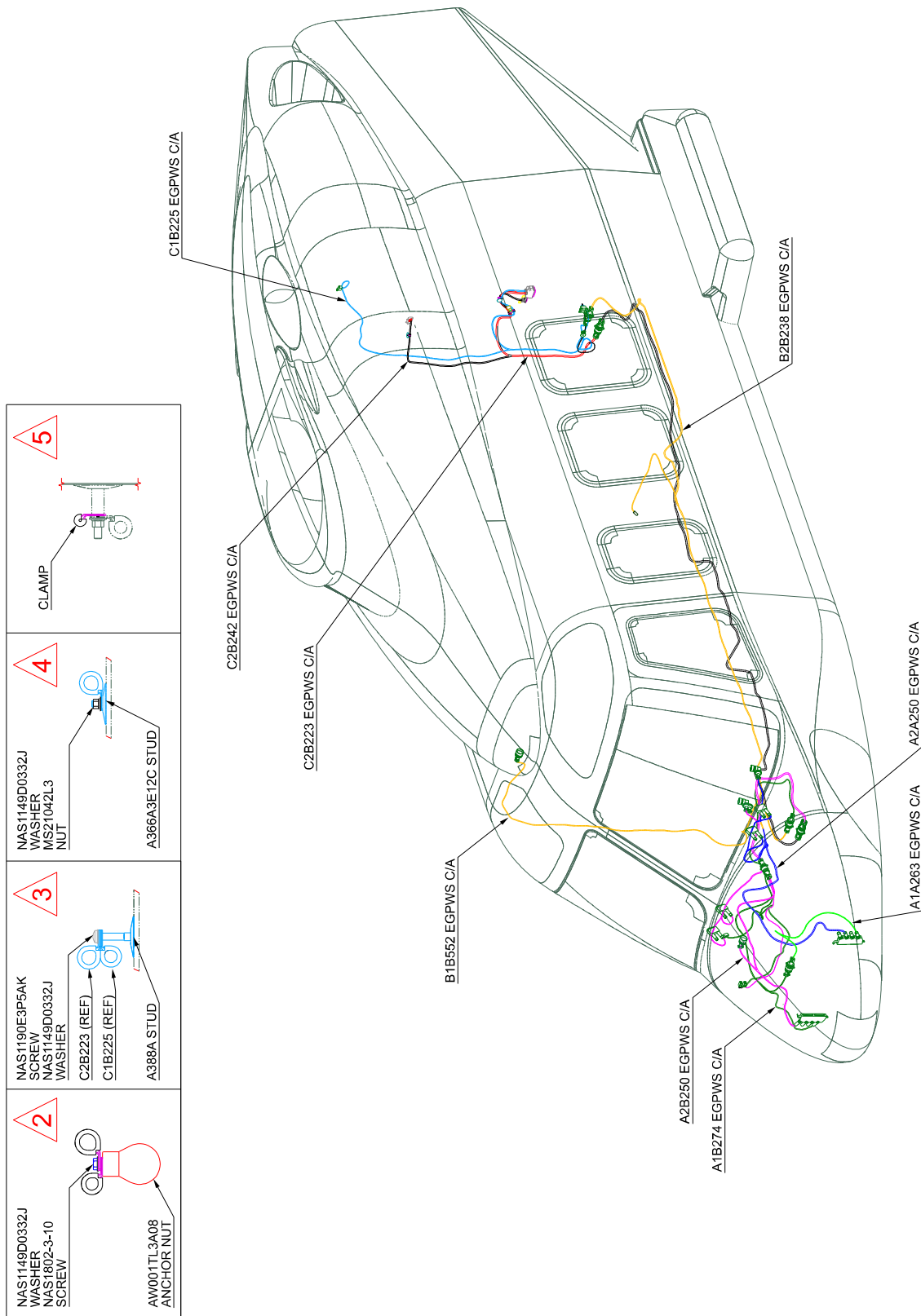
S.B. N°139-705  
DATE: May 11, 2023  
REVISION: /



**SECTION H-H**

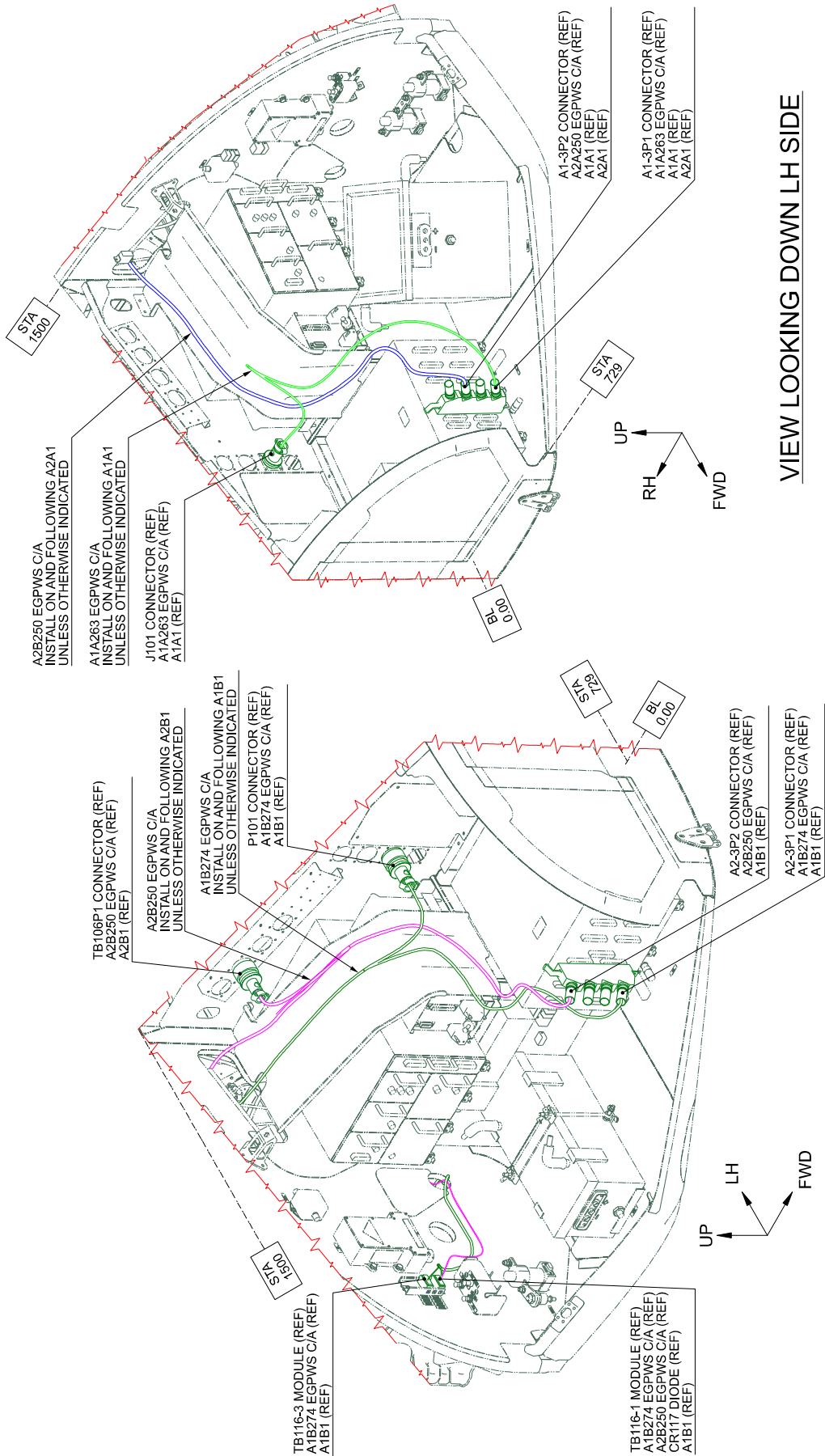


**Figure 2**

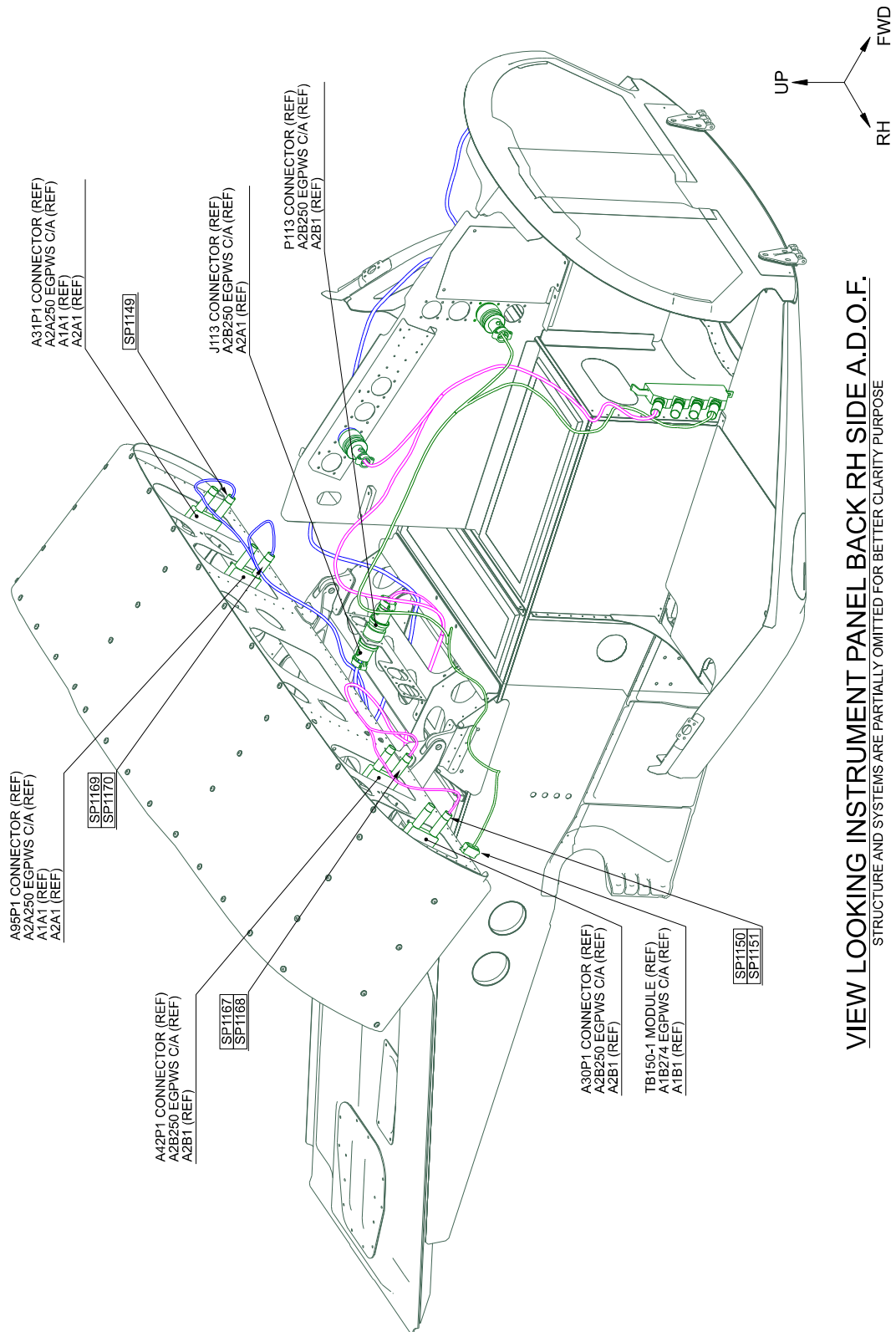


**Figure 3**

S.B. N°139-705  
DATE: May 11, 2023  
REVISION: /



**Figure 4**

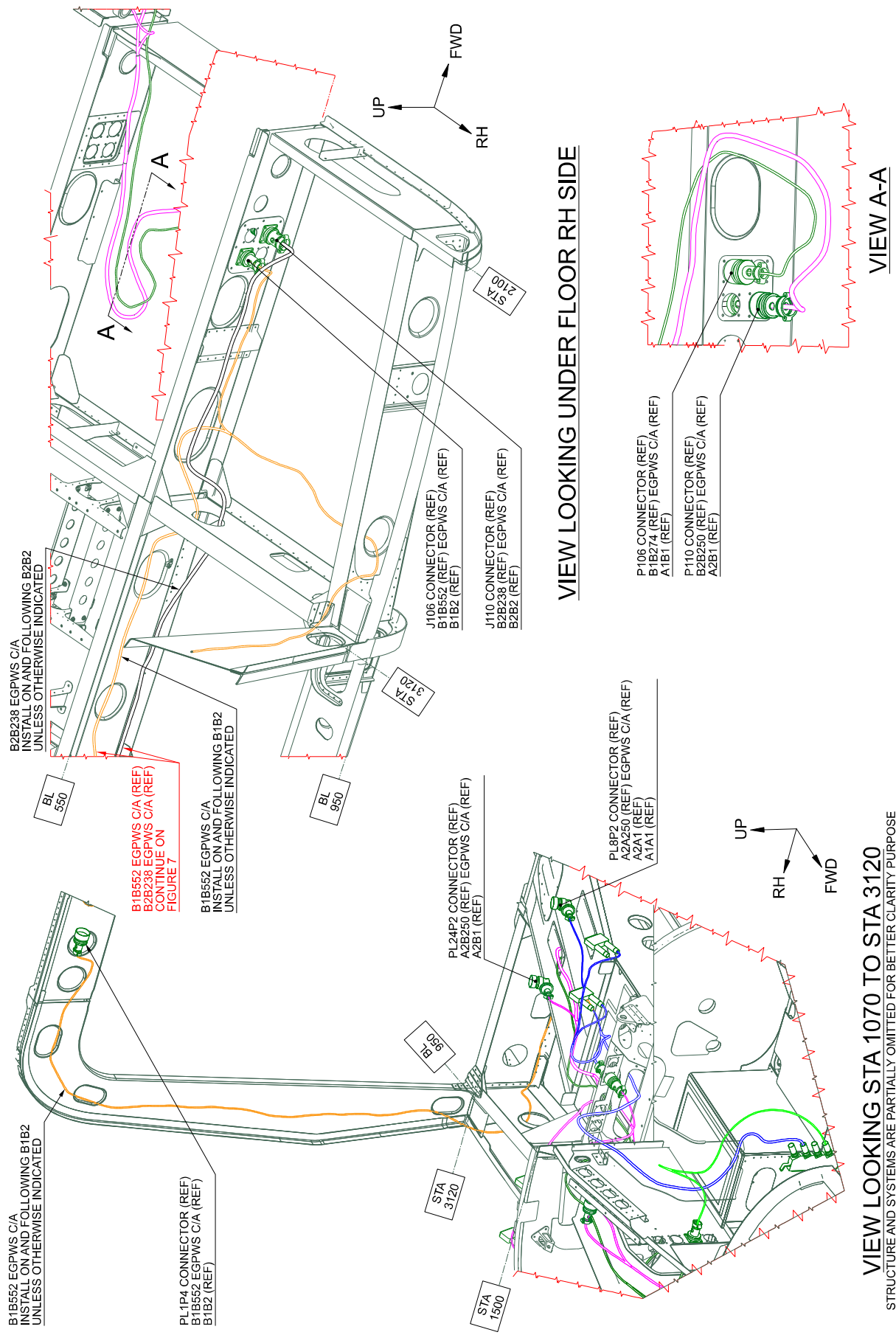


**VIEW LOOKING INSTRUMENT PANEL BACK RH SIDE A.D.O.F.**

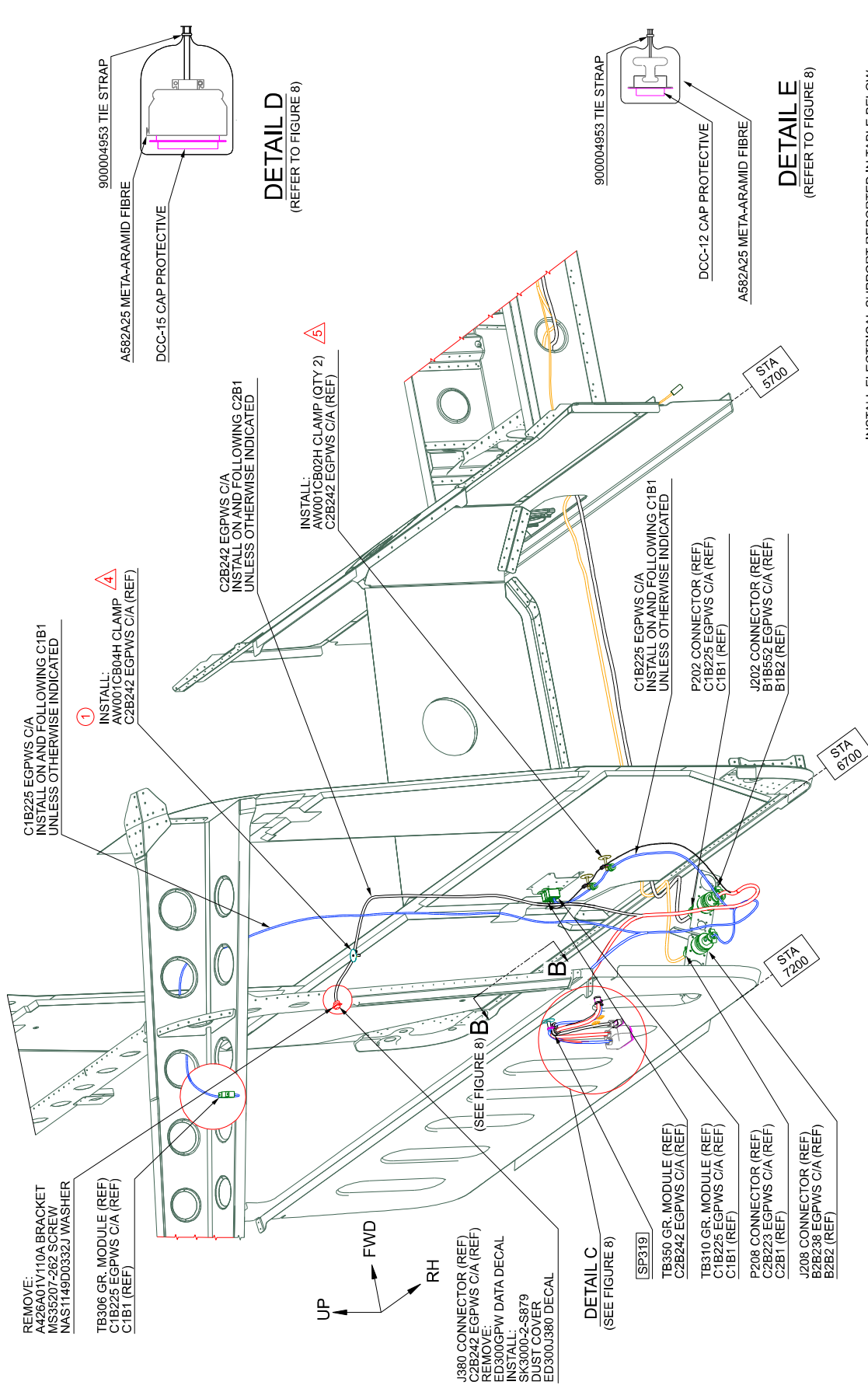
STRUCTURE AND SYSTEMS ARE PARTIALLY OMITTED FOR BETTER CLARITY PURPOSE

**Figure 5**





**Figure 6**

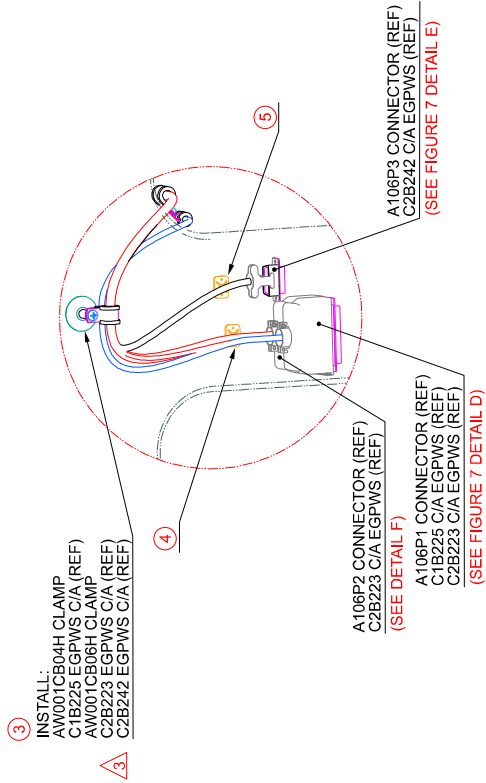


INSTALL ELECTRICAL SUPPORT REPORTED IN TABLE BELOW:

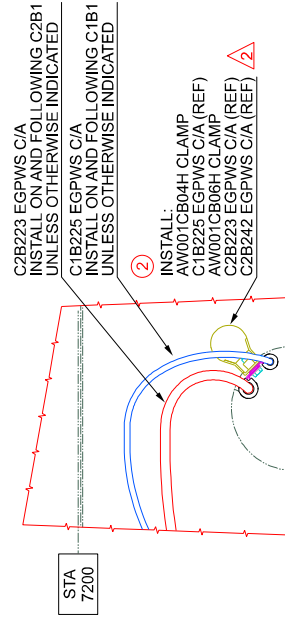
LOCATION NUMBER	PART NUMBER	STA	BL	WL	ORIENTATION
①	A366A3E12C	7058	759	2106	-

**VIEW LOOKING REAR AREA RH SIDE**  
 STRUCTURE AND SYSTEMS ARE PARTIALLY OMITTED FOR BETTER CLARITY PURPOSE

**Figure 7**



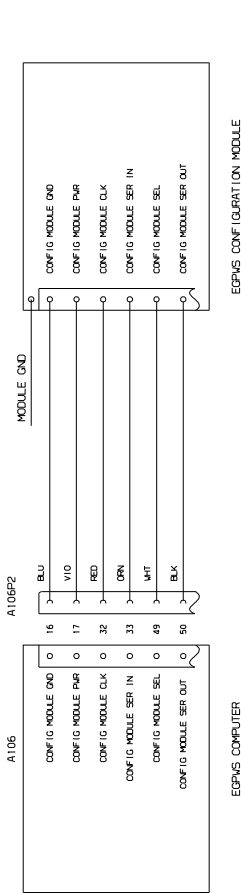
**DETAIL C**  
(REFER TO FIGURE 7)



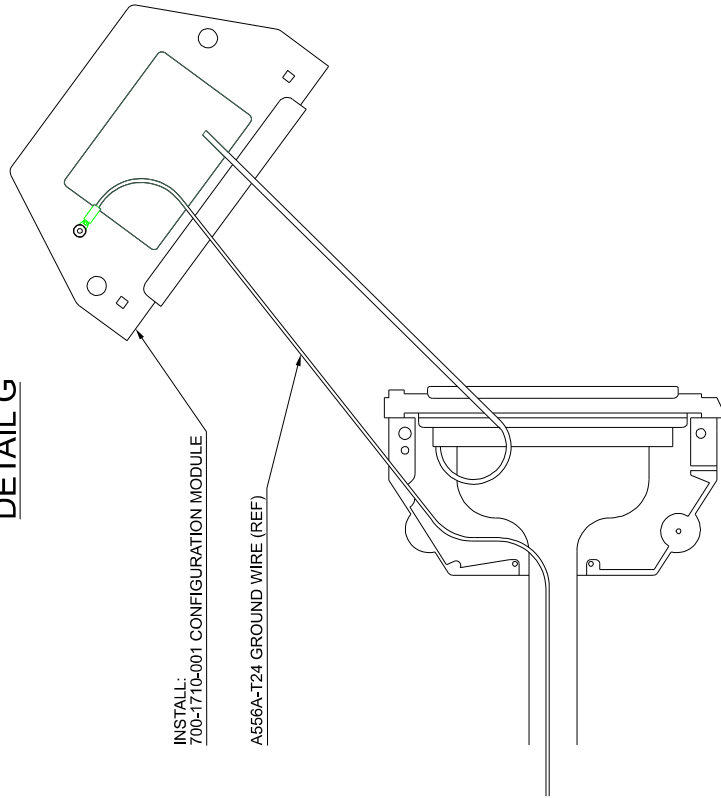
**VIEW B-B**  
(REFER TO FIGURE 7)

INSTALL ELECTRICAL SUPPORT REPORTED IN TABLE BELOW:

LOCATION NUMBER	PART. NUMBER	STA	BL	WL	ORIENTATION
2	AW001TL3A08	7200	685	1427	135°
3	A388A3E08C	7200	601	1503	-
4	AW001CL001-N6	7200	563	1364	0°
5	AW001CL001-N6	7200	613	1364	0°



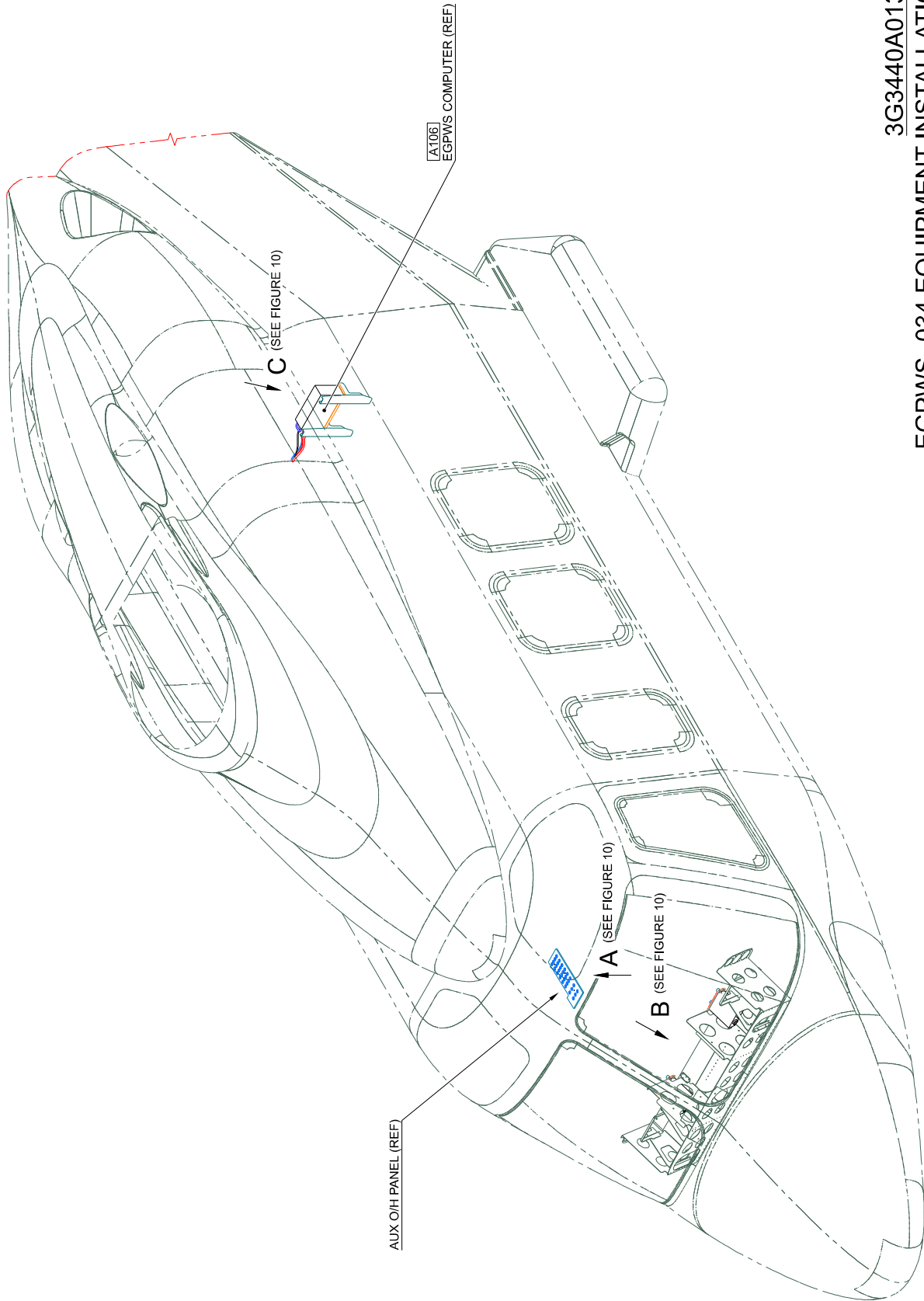
**DETAIL G**



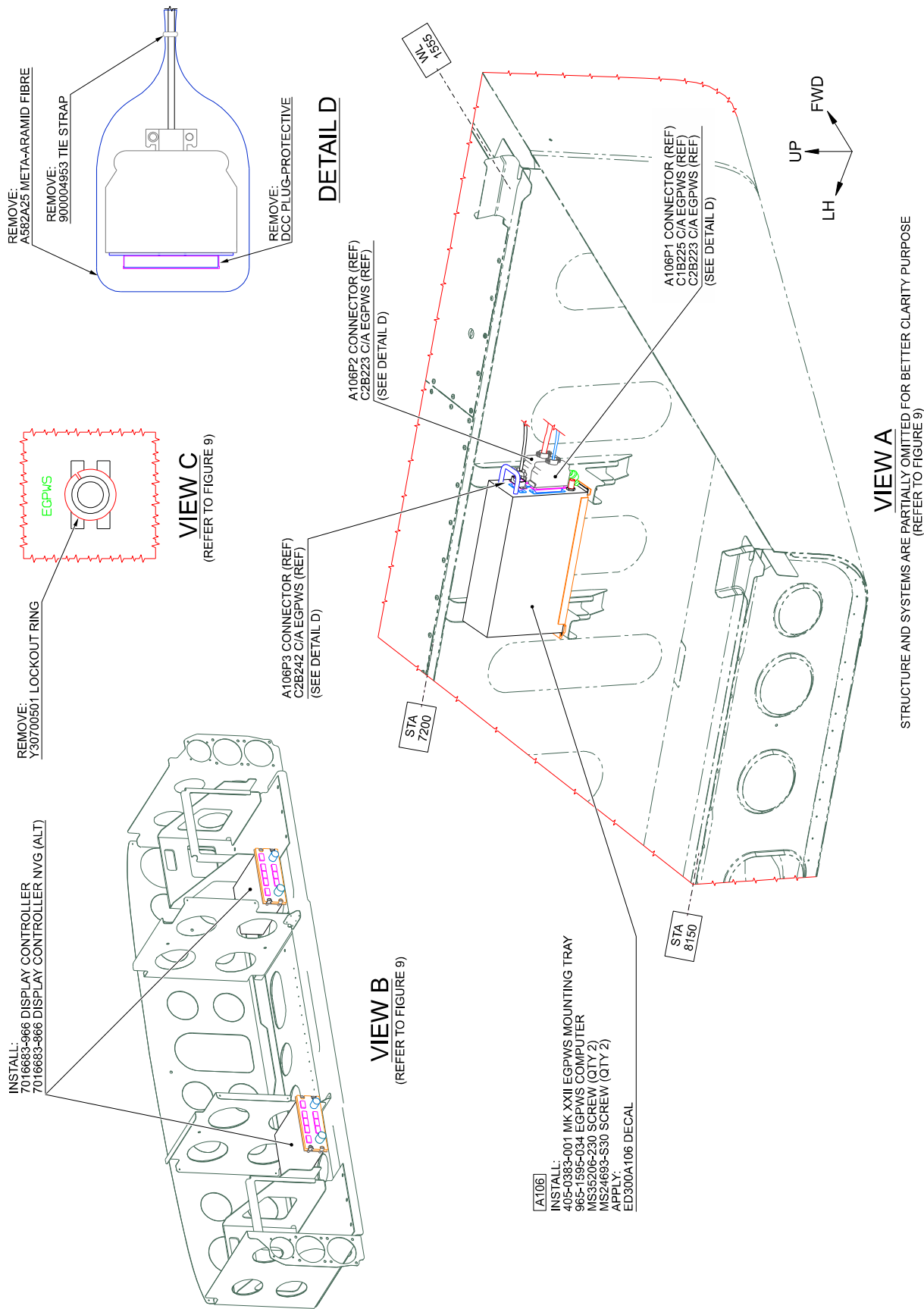
**DETAIL F**

STRUCTURE AND SYSTEMS ARE PARTIALLY OMITTED FOR BETTER CLARITY PURPOSE

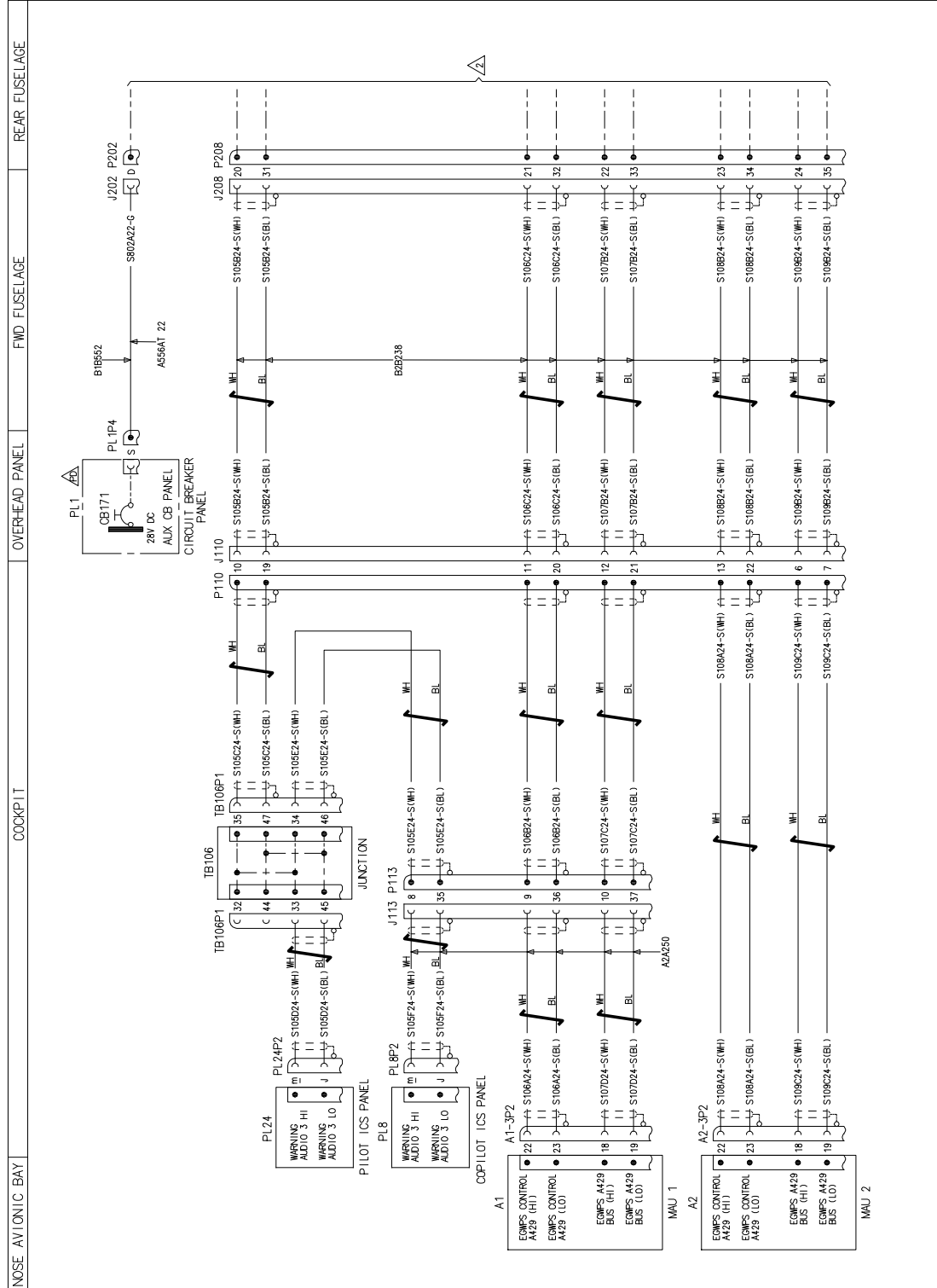
Figure 8



**Figure 9**



**Figure 10**



DRAWING REF. KEY  
SHEET NO. 2  
FEEDER BUSBARS  
3246W001\*\*

**Figure 11**

FUNCTIONAL NOTES

ALL CABLES ARE IN LOOM A2B250 UNLESS SPECIFIED.  
ALL CABLES ARE OF TYPE A86/A12 24 UNLESS SPECIFIED

### EGPWS C/A (A2B250)

CABLE ASSY	REF-DES	PIN	CONTACT P/N	INSULATION SLEEVING
A2B250	A2-3P2	22	M39029/67-354	M23053/8-004-C
A2B250	A2-3P2	23	M39029/67-354	M23053/8-004-C
A2B250	A2-3P2	18	M39029/67-354	M23053/8-004-C
A2B250	A2-3P2	19	M39029/67-354	M23053/8-004-C
A2B250	P110	13	M39029/68-360	M23053/8-004-C
A2B250	P110	22	M39029/68-360	M23053/8-004-C
A2B250	P110	6	M39029/68-360	M23053/8-004-C
A2B250	P110	7	M39029/68-360	M23053/8-004-C
A2B250	P110	11	M39029/68-360	M23053/8-004-C
A2B250	P110	20	M39029/68-360	M23053/8-004-C
A2B250	P110	12	M39029/68-360	M23053/8-004-C
A2B250	P110	21	M39029/68-360	M23053/8-004-C
A2B250	P110	10	M39029/68-360	M23053/8-004-C
A2B250	P110	19	M39029/68-360	M23053/8-004-C
A2B250	P113	9	M39029/68-360	M23053/8-004-C
A2B250	P113	36	M39029/68-360	M23053/8-004-C
A2B250	P113	10	M39029/68-360	M23053/8-004-C
A2B250	P113	37	M39029/68-360	M23053/8-004-C
A2B250	P113	8	M39029/68-360	M23053/8-004-C
A2B250	P113	35	M39029/68-360	M23053/8-004-C
A2B250	PL24P2	J	M39029/67-357	M23053/8-004-C
A2B250	PL24P2	M	M39029/67-357	M23053/8-004-C
A2B250	TB106P1	45	M39029/66-348	M23053/8-004-C
A2B250	TB106P1	33	M39029/66-348	M23053/8-004-C
A2B250	TB106P1	35	M39029/66-348	M23053/8-004-C
A2B250	TB106P1	47	M39029/66-348	M23053/8-004-C
A2B250	TB106P1	34	M39029/66-348	M23053/8-004-C
A2B250	TB106P1	46	M39029/66-348	M23053/8-004-C

### EGPWS C/A (A2A250)

CABLE ASSY	REF-DES	PIN	CONTACT P/N	INSULATION SLEEVING
A2A250	A1-3P2	22	M39029/67-354	M23053/8-004-C
A2A250	A1-3P2	23	M39029/67-354	M23053/8-004-C
A2A250	A1-3P2	18	M39029/67-354	M23053/8-004-C
A2A250	A1-3P2	19	M39029/67-354	M23053/8-004-C
A2A250	PL8P2	M	M39029/67-357	M23053/8-004-C
A2A250	PL8P2	J	M39029/67-357	M23053/8-004-C
A2A250	J113	8	M39029/66-348	M23053/8-004-C
A2A250	J113	35	M39029/66-348	M23053/8-004-C
A2A250	J113	9	M39029/66-348	M23053/8-004-C
A2A250	J113	36	M39029/66-348	M23053/8-004-C
A2A250	J113	10	M39029/66-348	M23053/8-004-C
A2A250	J113	37	M39029/66-348	M23053/8-004-C

### EGPWS C/A (B2B238)

CABLE ASSY	REF-DES	PIN	CONTACT P/N	INSULATION SLEEVING
B2B238	J110	10	M39029/66-348	M23053/8-004-C
B2B238	J110	19	M39029/66-348	M23053/8-004-C
B2B238	J110	11	M39029/66-348	M23053/8-004-C
B2B238	J110	20	M39029/66-348	M23053/8-004-C
B2B238	J110	12	M39029/66-348	M23053/8-004-C
B2B238	J110	21	M39029/66-348	M23053/8-004-C
B2B238	J110	13	M39029/66-348	M23053/8-004-C
B2B238	J110	22	M39029/66-348	M23053/8-004-C
B2B238	J110	6	M39029/66-348	M23053/8-004-C
B2B238	J110	7	M39029/66-348	M23053/8-004-C
B2B238	J206	20	M39029/66-348	M23053/8-004-C
B2B238	J206	31	M39029/66-348	M23053/8-004-C
B2B238	J206	21	M39029/66-348	M23053/8-004-C
B2B238	J206	32	M39029/66-348	M23053/8-004-C
B2B238	J206	22	M39029/66-348	M23053/8-004-C
B2B238	J206	33	M39029/66-348	M23053/8-004-C
B2B238	J206	23	M39029/66-348	M23053/8-004-C
B2B238	J206	34	M39029/66-348	M23053/8-004-C
B2B238	J206	24	M39029/66-348	M23053/8-004-C
B2B238	J206	35	M39029/66-348	M23053/8-004-C

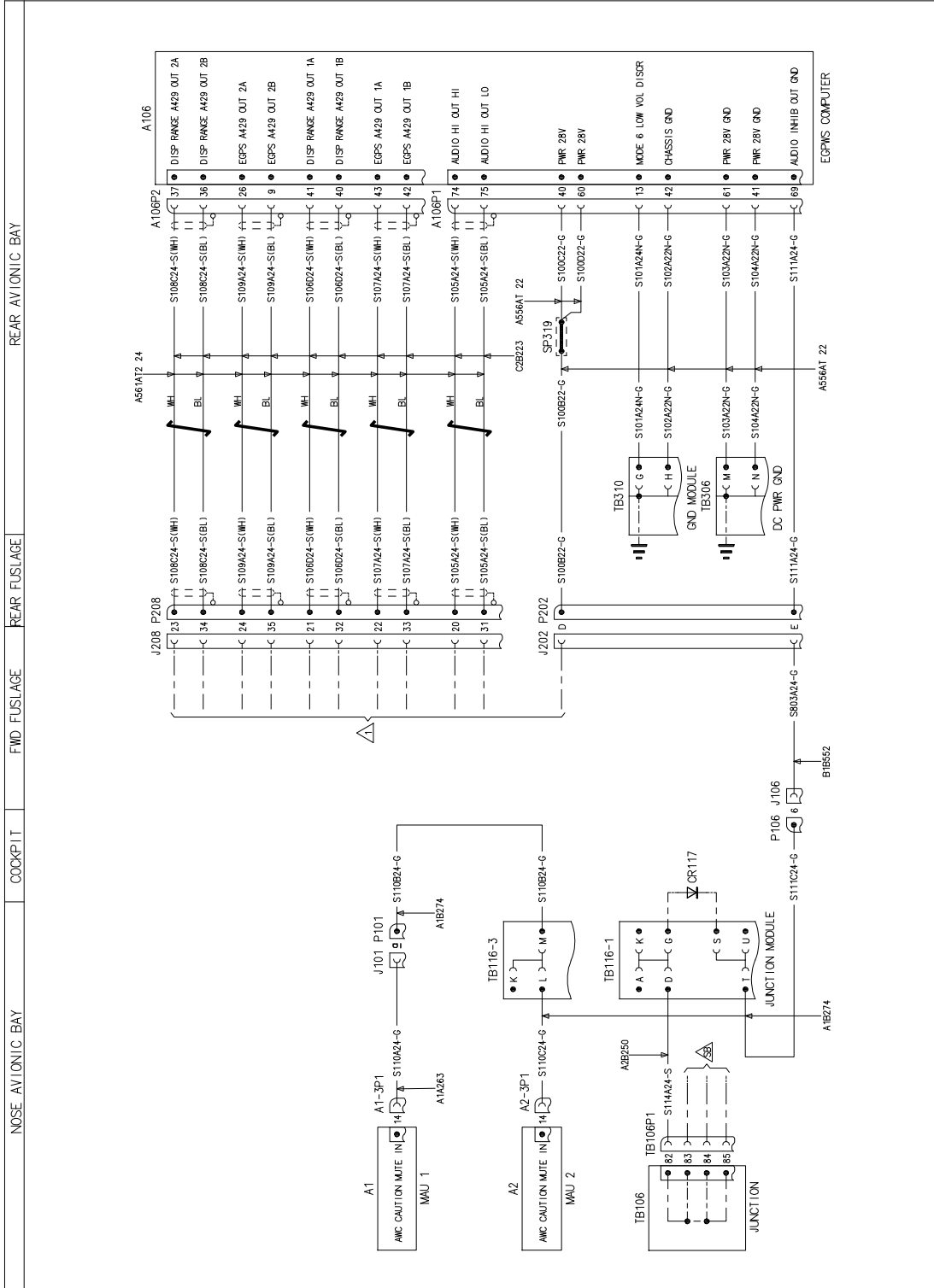
### EGPWS C/A (B1B552)

CABLE ASSY	REF-DES	PIN	CONTACT P/N	INSULATION SLEEVING
B1B552	J202	D	M39029/66-351	-
B1B552	PL1P4	S	M39029/68-363	-

Figure 12

DRAWING REF. KEY

- △ SHEET NO. 1
- △ CDS
- △ 3G3440W00321



FUNCTIONAL NOTES  
ALL CABLES ARE IN LOOM C1B225 UNLESS SPECIFIED.  
ALL CABLES ARE OF TYPE A556AT 24 UNLESS SPECIFIED

**Figure 13**



### EGPWS C/A (C1B225)

CABLE ASSY	REF-DES	PIN	CONTACT P/N	INSULATION SLEEVING
C1B225	P202	D	M39029/58-363	-
C1B225	P202	E	M39029/58-363	-
C1B225	TB306	N	001104-202-02	-
C1B225	TB306	M	001104-202-02	-
C1B225	TB310	G	001104-202-02	-
C1B225	TB310	H	001104-202-02	-

### EGPWS C/A (B1B552)

CABLE ASSY	REF-DES	PIN	CONTACT P/N	INSULATION SLEEVING
B1B552	J106	6	M39029/56-348	-
B1B552	J202	G	M39029/56-351	-

### EGPWS C/A (A2B250)

CABLE ASSY	REF-DES	PIN	CONTACT P/N	INSULATION SLEEVING
A2B250	TB106P1	82	M39029/56-348	M23053/8-004-C
A2B250	TB116-1	D	001104-202-02	-

### EGPWS C/A (A1B274)

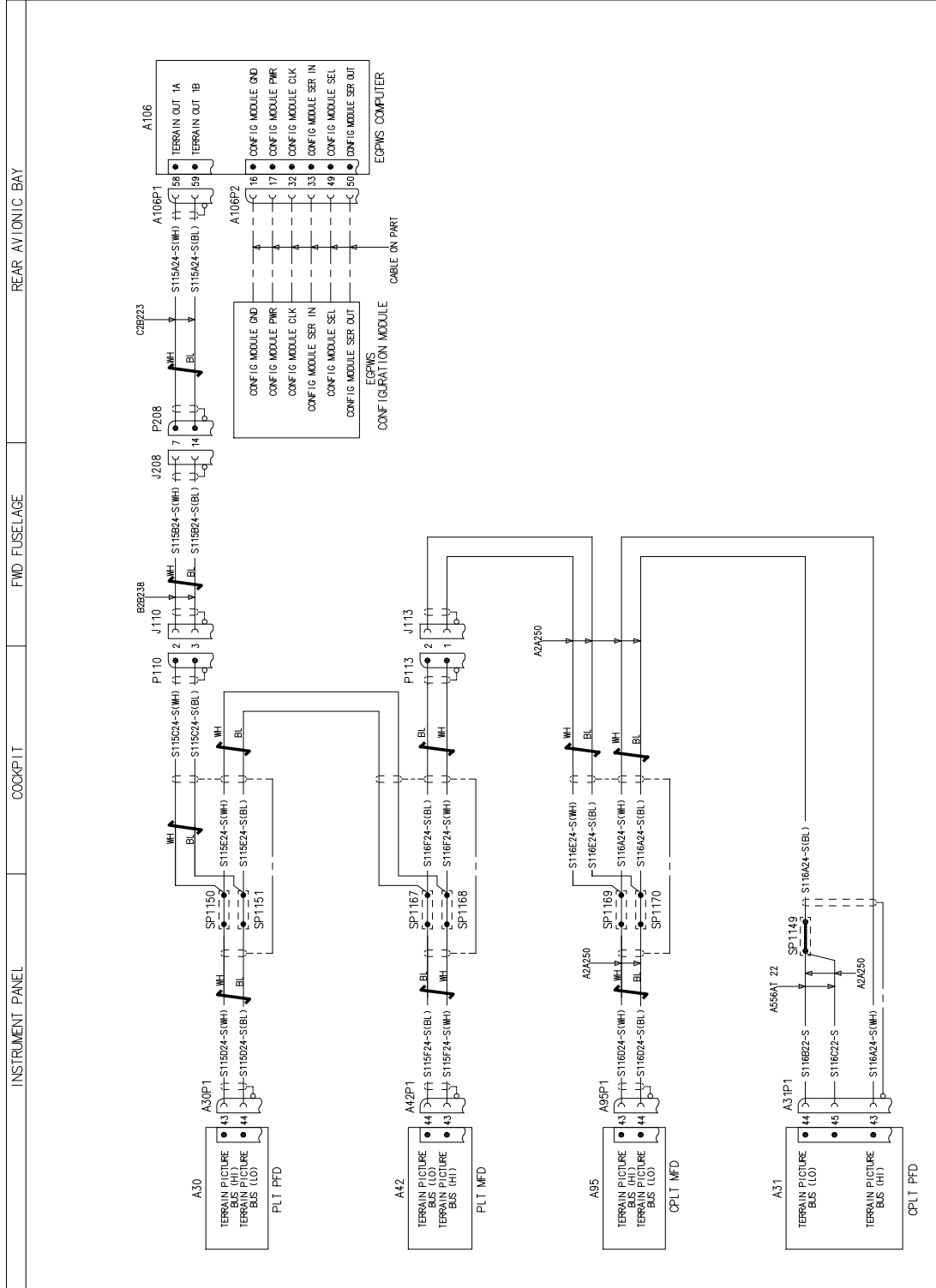
CABLE ASSY	REF-DES	PIN	CONTACT P/N	INSULATION SLEEVING
A1B274	A2-3P1	14	M39029/57-354	-
A1B274	P101	A	M39029/58-363	-
A1B274	P106	6	M39029/58-360	-
A1B274	TB116-1	T	001104-202-02	-
A1B274	TB116-3	L	001104-202-02	-
A1B274	TB116-3	M	001104-202-02	-

### EGPWS C/A (C2B223)

CABLE ASSY	REF-DES	PIN	CONTACT P/N	INSULATION SLEEVING
C2B223	A106P1	74	M39029/57-354	M23053/8-004-C
C2B223	A106P1	75	M39029/57-354	M23053/8-004-C
C2B223	P208	20	M39029/58-360	M23053/8-004-C
C2B223	P208	31	M39029/58-360	M23053/8-004-C
C2B223	P208	21	M39029/58-360	M23053/8-004-C
C2B223	P208	32	M39029/58-360	M23053/8-004-C
C2B223	P208	22	M39029/58-360	M23053/8-004-C
C2B223	P208	33	M39029/58-360	M23053/8-004-C
C2B223	P208	23	M39029/58-360	M23053/8-004-C
C2B223	P208	34	M39029/58-360	M23053/8-004-C
C2B223	P208	24	M39029/58-360	M23053/8-004-C
C2B223	P208	35	M39029/58-360	M23053/8-004-C

3G3440W00321  
 WIRING DIAGRAM EGPWS  
 SHEET 2

**Figure 14**



**Figure 15**

FUNCTIONAL NOTES  
ALL CABLES ARE IN LOOM A2B250 UNLESS SPECIFIED.  
ALL CABLES ARE OF TYPE M17-176-3000Z UNLESS SPECIFIED

### EGPWS C/A (A2B250)

CABLE ASSY	REF-DES	PIN	CONTACT P/N	INSULATION SLEEVING
A2B250	A30P1	43	M39029/57-354	M23053/8-005-C
A2B250	A30P1	44	M39029/57-354	M23053/8-005-C
A2B250	A42P1	44	M39029/57-354	M23053/8-005-C
A2B250	A42P1	43	M39029/57-354	M23053/8-005-C
A2B250	P110	2	M39029/58-360	M23053/8-004-C
A2B250	P110	3	M39029/58-360	M23053/8-004-C
A2B250	P113	2	M39029/58-360	M23053/8-005-C
A2B250	P113	1	M39029/58-360	M23053/8-005-C

### EGPWS C/A (A2A250)

CABLE ASSY	REF-DES	PIN	CONTACT P/N	INSULATION SLEEVING
A2A250	A31P1	44	M39029/57-354	-
A2A250	A31P1	45	M39029/57-354	-
A2A250	A31P1	43	M39029/57-354	M23053/8-005-C
A2A250	A95P1	43	M39029/57-354	M23053/8-005-C
A2A250	A95P1	44	M39029/57-354	M23053/8-005-C
A2A250	J113	1	M39029/56-348	M23053/8-005-C
A2A250	J113	2	M39029/56-348	M23053/8-005-C

### EGPWS C/A (B2B238)

CABLE ASSY	REF-DES	PIN	CONTACT P/N	INSULATION SLEEVING
A2B250	J110	2	M39029/56-348	M23053/8-005-C
A2B250	J110	3	M39029/56-348	M23053/8-005-C
A2B250	J208	7	M39029/56-348	M23053/8-005-C
A2B250	J208	14	M39029/56-348	M23053/8-005-C

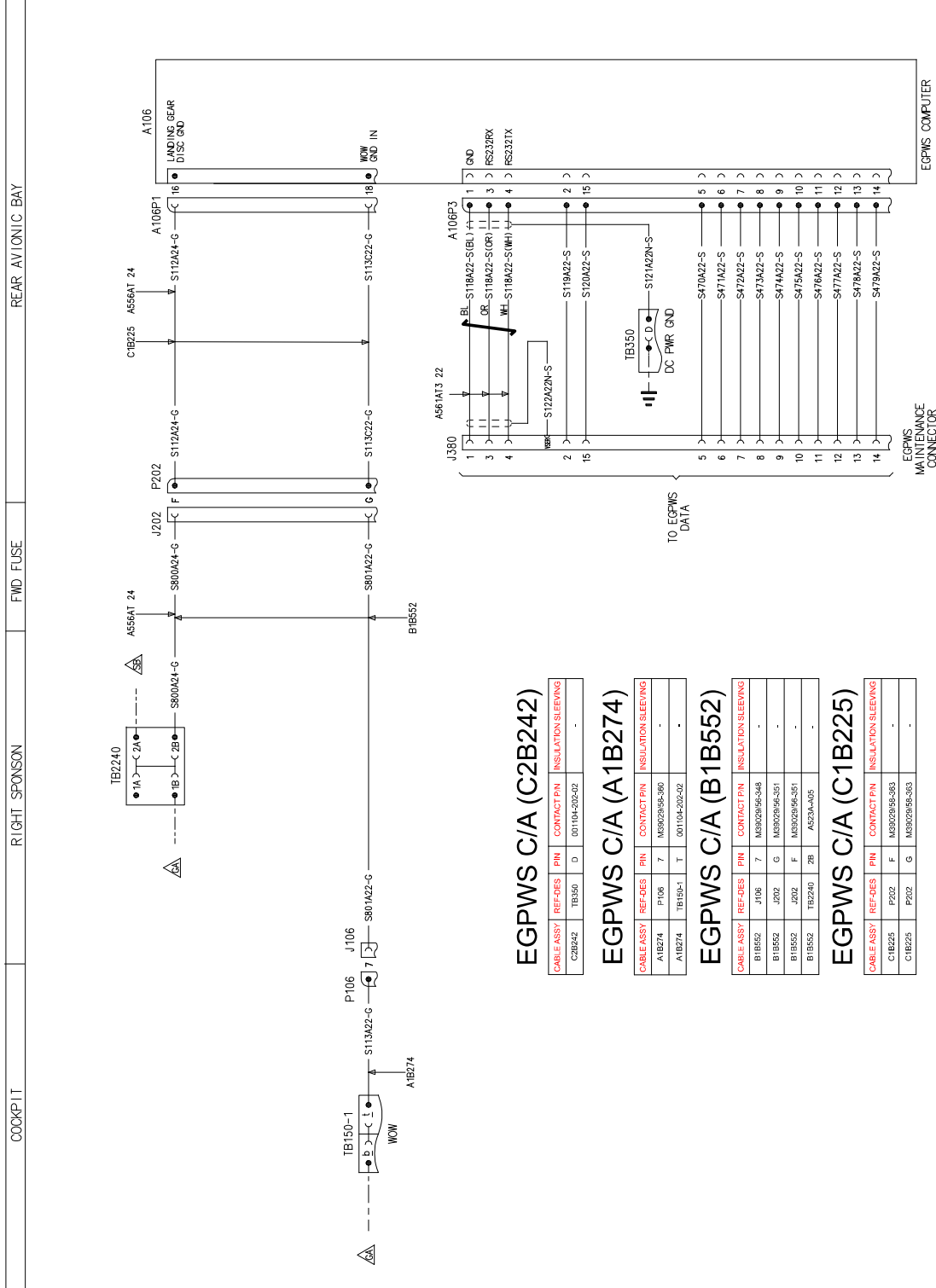
### EGPWS C/A (C2B223)

CABLE ASSY	REF-DES	PIN	CONTACT P/N	INSULATION SLEEVING
C2B223	A106P1	59	M39029/57-354	M23053/8-005-C
C2B223	A106P1	59	M39029/57-354	M23053/8-005-C
C2B223	P208	7	M39029/58-360	M23053/8-005-C
C2B223	P208	14	M39029/58-360	M23053/8-005-C

3G3440W00321  
 WIRING DIAGRAM EGPWS  
 SHEET 3

**Figure 16**

DRAWING REF. KEY  
 UNDERCARRIAGE  
 3G3440W001\*\*  
 TCS  
 3G3460W003\*\*



### EGWS C/A (C2B242)

CABLE ASSY	REF/DES	PN	CONTACT PN	INSULATION SLEEVING
C2B242	TB350	D	001104-202-02	-

### EGWS C/A (A1B274)

CABLE ASSY	REF/DES	PN	CONTACT PN	INSULATION SLEEVING
A1B274	P106	7	M93029196-380	-
A1B274	TB150-1	T	001104-202-02	-

### EGWS C/A (B1B552)

CABLE ASSY	REF/DES	PN	CONTACT PN	INSULATION SLEEVING
B1B552	J106	7	M93029196-348	-
B1B552	J202	G	M93029196-351	-
B1B552	J202	F	M93029196-351	-
B1B552	TB2240	ZB	A522A-005	-

### EGWS C/A (C1B225)

CABLE ASSY	REF/DES	PN	CONTACT PN	INSULATION SLEEVING
C1B225	P202	F	M93029196-383	-
C1B225	P202	G	M93029196-383	-

3G3440W00321  
 WIRING DIAGRAM EGWS  
 SHEET 4

FUNCTIONAL NOTES  
 ALL CABLES ARE IN LOW C2B242 UNLESS SPECIFIED.  
 ALL CABLES ARE OF TYPE A556AT 22

Figure 17

Please send to the following address:  <b>LEONARDO S.p.A.</b> <b>CUSTOMER SUPPORT &amp; SERVICES - ITALY</b>  <b>PRODUCT SUPPORT ENGINEERING &amp; LICENSES DEPT.</b> Via Giovanni Agusta, 520 21017 Cascina Costa di Samarate (VA) - ITALY Tel.: +39 0331 225036 Fax: +39 0331 225988	<b>SERVICE BULLETIN COMPLIANCE FORM</b>	Date:
Number:		
Revision:		

Customer Name and Address:	Telephone:
	Fax:
	B.T. Compliance Date:

Helicopter Model	S/N	Total Number	Total Hours	T.S.O.

Remarks:

**Information:**

We request your cooperation in filling this form, in order to keep out statistical data relevant to aircraft configuration up-to-date. The form should be filled in all its parts and sent to the above address or you can communicate the application also via Technical Bulletin Application Communication Section placed in Leonardo AW Customer Portal - MyCommunications Area. We thank you beforehand for the information given.