

# CONTINUING AIRWORTHINESS MANAGEMENT EXPOSITION (CAME)

**Organisation** : GALAXY AEROSPACE (M) SDN. BHD.  
**Approval No** : DGTA CAMO/01  
**Address** : Suite 11-14, Helicopter Centre,  
Malaysia International Aerospace Centre (MIAC),  
Sultan Abdul Aziz Shah Airport,  
47200 Subang,  
Selangor Darul Ehsan  
**Tel No** : +603 7734 7226  
**Fax No** : +603 7734 7526  
**Email** : [camo@galaxyaerospace.my](mailto:camo@galaxyaerospace.my)  
**CAME Reference No** : GAM/DGTA/CAME  
**Issue Number** : Issue 1  
**Revision Number** : Revision 0  
**Date of Issue** : 21 June 2023  
**Date of Revision** : Initial  
**Copy Number** : GAM/DGTA/CAME/03  
**Copy Holder** : CAMO Publication

	<b>Continuing Airworthiness Management Exposition (CAME)</b>	
	Issue No.	<b>1</b>
	Revision No.	<b>0</b>

## **INTRODUCTION**

### **I. FOREWORD**

This Exposition defines the organisation and procedures upon which the Directorate General Technical Airworthiness (DGTA) approval of GALAXY AEROSPACE (M) SDN. BHD. – CONTINUING AIRWORTHINESS MANAGEMENT ORGANISATION (GAM CAMO) under TAO-M Subpart G is based.

These procedures shall be complied with, as applicable, in order to ensure that all the continuing airworthiness activities including maintenance for aircraft managed by Galaxy Aerospace (M) Sdn. Bhd. is carried out on time and to an approved standard.

The exposition shall not override the necessity of complying with any new or amended regulation published by the DGTA from time to time where these new or amended regulations conflict with these procedures and shall be reviewed and updated as required.

The DGTA reserves the right to suspend, vary or revoke the continuing airworthiness management approval of GAM CAMO, as applicable, if the DGTA has evidence that procedures are not followed and the standards are not upheld.

## II. TABLE OF CONTENT

INTRODUCTION.....	1
I. FOREWORD.....	1
II. TABLE OF CONTENT .....	2
III. LIST OF EFFECTIVE PAGES .....	6
IV. AMENDMENT RECORD .....	9
a. Direct Approval Amendments .....	9
b. Indirect Approval Amendments .....	10
V. DISTRIBUTION LIST.....	11
VI. ABBREVIATIONS LIST .....	12
<b>PART 0 GENERAL ORGANISATION.....</b>	<b>1</b>
0.1. CORPORATE COMMITMENT BY THE ACCOUNTABLE MANAGER.....	1
0.1.1. General Information .....	2
0.1. A. Brief Description of the Organisation .....	2
0.1. B. Relationship with Other Organisation .....	2
0.1. C. Aircraft Managed – Fleet Composition.....	3
0.1.C.1. Quote Aircraft Types / Series.....	3
0.1.C.2. Date Included in the Scope of Work .....	3
0.1.C.3. List of Aircraft Maintenance Programmes.....	3
0.1.C.4. List of Generic and Baseline Maintenance Programmes.....	3
0.1.C.5. The Number of Aircraft and Registration of Each Type .....	4
0.1. D. Type of Operation .....	4
0.2. MANAGEMENT PERSONNEL.....	5
0.2.0. General .....	5
0.2. A. Accountable Manager (AM) .....	5
0.2. B. Continuing Airworthiness Manager (CAM).....	5
0.2. C. Continuing Airworthiness Coordination .....	5
0.2.C.1. Deputy to Nominated Persons .....	6
0.2. D. Duties and Responsibilities .....	7
0.2.D.1. Accountable Manager .....	7
0.2.D.2. Continuing Airworthiness Manager .....	7
0.2.D.3. Quality Manager (QM) .....	8
0.2.D.4. CAMO Personnel.....	9
0.2.D.4.1. Deputy CAM.....	9
0.2.D.4.2. CAMO Planner.....	9
0.2.D.4.3. Technical Publication .....	10
0.2.D.4.4. Technical Records .....	11
0.2.D.4.5. Technical Service.....	11
0.2. E. Manpower Resources and Training Policy .....	12
0.2.E.1. Manpower Resources .....	12
0.2.E.2. Training Policy .....	12
0.3. MANAGEMENT ORGANISATION CHARTS .....	15
0.3.1. General Organisation Chart .....	15
0.3.2. Continuing Airworthiness Management Organisation Chart .....	15
0.4. NOTIFICATION PROCEDURE TO THE DGTA REGARDING CHANGES TO THE ORGANISATION'S ACTIVITIES / APPROVAL / LOCATION / PERSONNEL .....	16
0.4. A. Changes.....	16
0.4. B. Notification Before Such Changes Take Place.....	16
0.4. C. Conduct a Risk Assessment for Any Change Requiring Prior Approval and Provide it to DGTA Upon Request.....	16
0.4. D. Internal Pre-Audit Before Application.....	17
0.5. CAME AMENDMENT PROCEDURE.....	18
0.5.1. General .....	18
0.5. A. Amendments That Need Prior Approval .....	18
0.5. B. Amendments Not Requiring Prior Approval .....	18

0.5. C.	Description of How Such Amendments Will Be Managed .....	19
0.5. D.	The Person is Responsible for Amending the Exposition .....	19
0.5. E.	Sources of Proposed Amendments Within the Organisation .....	19
0.5. F.	Internal Approval Process .....	19
0.5. G.	The Approval Process with DGTA .....	20
0.5. H.	Revision Acknowledges Receipt Process .....	20
0.5. I.	Definition of Minor Amendments to the Exposition That Can Be Amended Without the Prior Approval of the DGTA .....	20
0.5. J.	Summary of Documents, Including 'Lower Order' Documents, Constituting the Total Exposition .....	20
0.5. K.	The Effective Date of the Amendment .....	21
0.5. L.	CAME Review .....	21
<b>PART 1</b>	<b>CONTINUING AIRWORTHINESS MANAGEMENT PROCEDURES .....</b>	<b>1</b>
1.1.	UTILISATION OF AIRCRAFT CONTINUING AIRWORTHINESS RECORD SYSTEM AND AIRCRAFT TECHNICAL LOG AND MEL AND/OR CDL .....	1
1.1.A.	AIRCRAFT TECHNICAL LOG AND CONTINUING AIRWORTHINESS RECORD SYSTEM .....	1
1.1.A.1.	General .....	1
1.1.A.2.	Instruction For Use .....	2
1.1.A.3.	Aircraft Technical Log Approval .....	2
1.1.A.4.	The Records System .....	2
1.1.B.	MINIMUM EQUIPMENT LIST (MEL) AND/OR CONFIGURATION DEVIATION LIST (CDL) UTILISATION .....	3
1.1.B.0	General .....	3
1.1.B.1	MEL/CDL Categories .....	4
1.1.B.2	Utilisation .....	4
1.1.B.3	Acceptance by the Aircraft Commander .....	5
1.1.B.4	Management of the MEL/CDL Time Limits .....	5
1.1.B.5	MEL/CDL Time Limitation Overrun .....	5
1.2.	AIRCRAFT MAINTENANCE PROGRAMME (AMP) .....	6
1.2.A.	General .....	6
1.2.B.	Content .....	6
1.2.C.	Development .....	9
1.2.C.1.	SOURCES .....	9
1.2.C.2.	RESPONSIBILITIES .....	10
1.2.C.3.	AMP AMENDMENTS .....	10
1.2.C.4.	ACCEPTANCE BY THE DGTA .....	12
1.3.	USAGE AND CONTINUING AIRWORTHINESS RECORDS: RESPONSIBILITIES, RETENTION AND ACCESS .....	13
1.3.A.	FLYING HOURS, FLIGHT CYCLES, LANDINGS RECORDING .....	13
1.3.B.	RECORDS .....	13
1.3.C.	PRESERVATION OF CONTINUING AIRWORTHINESS RECORDS .....	15
1.3.D.	TRANSFER OF CONTINUING AIRWORTHINESS RECORDS .....	15
1.3.E.	COMPUTER RECORDS SYSTEM BACKUP .....	16
1.3.F.	BACKUP DATA STORAGE LOCATION .....	16
1.3.G.	ACCESS TO CONTINUING AIRWORTHINESS RECORDS .....	17
1.4.	ACCOMPLISHMENT AND CONTROL OF AIRWORTHINESS DIRECTIVE .....	18
1.4.0.	GENERAL .....	18
1.4.A.	AIRWORTHINESS DIRECTIVE INFORMATION .....	18
1.4.B.	AIRWORTHINESS DIRECTIVE DECISION .....	18
1.4.C.	AIRWORTHINESS DIRECTIVE CONTROL .....	19
1.5.	ANALYSIS OF THE EFFECTIVENESS OF THE AMP .....	21
1.5.A.	PROCEDURES TO ANALYSE THE EFFECTIVENESS OF THE AMP .....	21
1.5.B.	AMP MANAGEMENT PROCESS .....	21
1.5.B.1.	AMENDMENT TO THE AMP .....	21
1.5.B.2.	AMENDMENT TO THE MAINTENANCE OR OPERATIONAL PROCEDURES .....	21
1.5.B.3.	LIAISON MEETINGS .....	21
1.5.B.4.	FREQUENCY OF MEETINGS .....	22
1.6.	NON-MANDATORY MODIFICATION EMBODIMENT POLICY .....	23
1.6.0.	GENERAL .....	23

1.6.A.	POLICY.....	23
1.6.B.	PROCEDURES TO ASSESS/ANALYSE AND DECISIONS TAKEN .....	23
1.6.B.1.	THE DECISION ON THEIR APPLICATION.....	23
1.6.B.2.	USE OF THE ORGANISATION'S RISK MANAGEMENT PROCESS .....	23
1.6.B.3.	RECORDS KEEPING OF THE ASSESSMENT/ANALYSE RISK MANAGEMENT AND DECISIONS ARE TAKEN .....	23
1.6.C.	MODIFICATION – GENERAL .....	24
1.6.D.	INSPECTIONS .....	24
1.6.E.	SERVICE BULLETIN & SERVICE LETTER.....	24
1.6.F.	THE OTHER MODIFICATIONS .....	25
1.6.G.	MINOR MODIFICATIONS .....	25
1.6.H.	STANDARD CHANGES AND STANDARD REPAIRS .....	25
1.6.I.	INSTRUCTION FOR CONTINUING AIRWORTHINESS – AMP .....	25
1.6.J.	RECORDING OF MODIFICATION.....	26
1.6.K.	LIAISON WITH OPERATOR / OWNER .....	27
1.7	MAJOR REPAIR AND MODIFICATION STANDARDS .....	28
1.7.A.	MODIFICATION – GENERAL .....	28
1.7.B.	TYPE OF APPROVAL REQUIRED.....	28
1.7.C.	ASSESSMENT.....	28
1.7.D.	INSTRUCTION FOR CONTINUING AIRWORTHINESS – AMP .....	29
1.7.E.	CRITICAL DESIGN CONFIGURATION CONTROL LIMITATION (CDCCL).....	29
1.7.F.	RECORDING OF MODIFICATION.....	29
1.7.G.	LIAISON WITH OPERATOR / OWNER .....	30
1.8.	DEFECT REPORTS .....	31
1.8.A.	Analysis.....	31
1.8.B.	Liaison with Manufacturers and DGTA .....	32
1.8.C.	Deferred Defect Policy .....	32
1.8.D.	Non Deferrable Defects Away From Base .....	33
1.8.E.	Repetitive Defects .....	33
1.8.F.	Mandatory Occurrence Reporting.....	33
1.8.G.	Liaison Meetings .....	34
1.9.	ENGINEERING ACTIVITY .....	36
1.9.A.	Procedure for Approval of Modifications and Repairs.....	36
1.9.B.	The Person Responsible for Accepting the Design Before Submission to the DGTA .....	36
1.9.C.	Developing and submitting a modification/repair design for approval to DGTA.....	36
1.9.D.	Application process .....	36
1.9.E.	Supporting documents .....	37
1.9.F.	Form used .....	37
1.9.G.	GAM (M)DOA Capability Under TAO-21 .....	37
1.10.	RELIABILITY PROGRAMMES.....	38
1.10.0.	General .....	38
1.10.A.	Extent and Scope of the Reliability Programme.....	38
1.10.B.	Organisational Structure, Duties and Responsibilities .....	39
1.10.C.	Establishment of Reliability Data.....	39
1.10.D.	Analysis of Reliability Data.....	40
1.10.E.	Corrective Action System.....	41
1.10.F.	Scheduled Reviews.....	42
1.11.	PRE-FLIGHT INSPECTIONS.....	44
1.11.0	General .....	44
1.11.A	Preparation of Aircraft for Flight .....	44
1.11.B	Concurrent with AMP .....	45
1.11.C	Control Publishing Guidance To Maintenance And Flight Personnel To Perform Pre-Flight Inspection And Defining Responsibilities For These Actions.....	45
1.11.D	Responsibility For Training Personnel Performing The Pre-Flight Inspection.....	46
1.11.E	Content of Pre-Flight Inspection Training.....	46
1.11.F	Records of Training.....	46
1.12.	AIRCRAFT WEIGHING.....	47
1.13.	MAINTENANCE CHECK FLIGHT PROCEDURES .....	49
1.13.1.	General .....	49

1.13.2.	Check Flight Procedure.....	49
<b>PART 2</b>	<b>QUALITY SYSTEM .....</b>	<b>1</b>
2.1.	CONTINUING AIRWORTHINESS QUALITY POLICY, QUALITY PLAN AND QUALITY AUDIT PROCEDURE .....	1
2.1.A.	Continuing Airworthiness Quality Policy.....	1
2.1.B.	Quality Plan (Programme).....	2
2.1.C.	Quality Audit Procedure .....	3
2.1.D.	Quality Audit Remedial Action Procedure .....	4
2.2	MONITORING OF CONTINUING AIRWORTHINESS MANAGEMENT ACTIVITIES .....	6
2.3	MONITORING OF THE EFFECTIVENESS OF THE MAINTENANCE PROGRAMME .....	7
2.4	MONITORING THAT ALL MAINTENANCE IS CARRIED OUT BY AN APPROPRIATE TAO-145 APPROVED MAINTENANCE ORGANISATION (AMO) .....	8
2.5	MONITORING THAT ALL CONTRACTED/TASKED MAINTENANCE IS CARRIED OUT IN ACCORDANCE WITH THE CONTRACT/TASKING, INCLUDING MAINTENANCE ORGANISATION NOT APPROVED TO TAO-145 USED BY THE MAINTENANCE CONTRACTOR/TASKED ORGANISATION .....	9
2.6	QUALITY AUDIT PERSONNEL .....	10
<b>PART 3</b>	<b>CONTRACTED MAINTENANCE .....</b>	<b>1</b>
3.1	MAINTENANCE CONTRACTOR / TASKED ORGANISATION SELECTION PROCEDURE .....	1
3.2	QUALITY AUDIT OF AIRCRAFT.....	3
3.3	QUALITY AUDIT OF SUB-CONTRACTED CAMO TASKS .....	4
<b>PART 4</b>	<b>AIRWORTHINESS REVIEW PROCEDURES .....</b>	<b>1</b>
4.1	AIRWORTHINESS REVIEW STAFF .....	1
4.2	REVIEW OF AIRCRAFT RECORDS.....	2
4.3	PHYSICAL SURVEY .....	4
4.4	ADDITIONAL PROCEDURES FOR RECOMMENDATIONS TO DGTA FOR THE IMPORT OF AIRCRAFT/USED AIRCRAFT .....	5
4.5	RECOMMENDATION TO DGTA FOR THE ISSUE OF A C OF A RENEWAL.....	6
4.6	ISSUANCE OF A C OF A RENEWAL.....	7
4.7	AIRWORTHINESS REVIEW RECORDS, RESPONSIBILITIES, RETENTION AND ACCESS.....	8
4.8	C OF A RENEWAL.....	9
<b>PART 4B</b>	<b>PERMIT TO FLY .....</b>	<b>1</b>
<b>PART 5</b>	<b>APPENDICES .....</b>	<b>1</b>
5.1	SAMPLE DOCUMENTS.....	1
5.2	LIST OF AIRWORTHINESS REVIEW STAFF .....	11
5.3	LIST OF CONTRACTED/TASKED ORGANISATION .....	12
5.4	LIST OF CONTRACTED/TASKED TAO-145 AMOs .....	13
5.5	COPY OF CONTRACTS/TASKINGS FOR CONTRACTED/TASKED WORK .....	14
5.6	COPY OF CONTRACTS/TASKINGS WITH TAO-145 AMOs .....	15
5.7	LIST OF OPERATING ORGANISATIONS TO WHOM CAMO PROVIDES THE MANAGEMENT OF THE CONTINUING AIRWORTHINESS OF THE AIRCRAFT .....	21
5.8	COPY OF CONTINUING AIRWORTHINESS ARRANGEMENTS WITH OPERATING ORGANISATIONS .....	22
5.9	MANPOWER RESOURCES AND MANAGEMENT TOOL.....	27

### III. LIST OF EFFECTIVE PAGES

CAME Part	CAME Chapter	Page No.	Issue No.	Revision	Date
INTRODUCTION	I.	1	1	0	21 June 2023
	II.	2 – 5	1	0	21 June 2023
	III.	6 – 8	1	0	21 June 2023
	IV.	9 – 10	1	0	21 June 2023
	V.	11	1	0	21 June 2023
	VI.	12 – 13	1	0	21 June 2023
0	0.1	1 – 4	1	0	21 June 2023
	0.2	5 – 14	1	0	21 June 2023
	0.3	15	1	0	21 June 2023
	0.4	16 – 17	1	0	21 June 2023
	0.5	18 – 21	1	0	21 June 2023
1	1.1	1 – 5	1	0	21 June 2023
	1.2	6 – 12	1	0	21 June 2023
	1.3	13 – 17	1	0	21 June 2023
	1.4	18 – 20	1	0	21 June 2023
	1.5	21 – 22	1	0	21 June 2023
	1.6	23 – 27	1	0	21 June 2023
	1.7	28 – 30	1	0	21 June 2023
	1.8	31 – 35	1	0	21 June 2023

The revised CAME had been internally reviewed for submission to DGTA for final approval		Approved by:
Prepared by:	Reviewed by:	
Continuing Airworthiness Manager	Quality Manager	Directorate General Technical Airworthiness
 ZATY NADHIRA BINTI MOHAMED ZUHARI Continuing Airworthiness Management Manager Galaxy Aerospace (M) Sdn Bhd (1040762-D)	 OMAR BIN AHMAD Quality Assurance Manager Galaxy Aerospace (M) Sdn. Bhd (1040262-D)	 MOHD ZUHARIS FIKRI BIN ISHAK Lt Kdr TLDM (N/404350) PS 2 NWSP Directorate General Technical Airworthiness
Date: 28 JUL 2023	Date: 28 JUL 2023	Date: 15 Sep 23

CAME Part	CAME Chapter	Page No.	Issue No.	Revision	Date
1	1.9	36 – 37	1	0	21 June 2023
	1.10	38 – 43	1	0	21 June 2023
	1.11	44 – 46	1	0	21 June 2023
	1.12	47 – 48	1	0	21 June 2023
	1.13	49 – 50	1	0	21 June 2023
2	2.1	1 – 5	1	0	21 June 2023
	2.2	6	1	0	21 June 2023
	2.3	7	1	0	21 June 2023
	2.4	8	1	0	21 June 2023
	2.5	9	1	0	21 June 2023
	2.6	10 – 11	1	0	21 June 2023
3	3.1	1 – 2	1	0	21 June 2023
	3.2	3	1	0	21 June 2023
	3.3	4	1	0	21 June 2023
4	4.1	1	1	0	21 June 2023
	4.2	2 – 3	1	0	21 June 2023
	4.3	4	1	0	21 June 2023
	4.4	5	1	0	21 June 2023
	4.5	6	1	0	21 June 2023
	4.6	7	1	0	21 June 2023

The revised CAME had been internally reviewed for submission to DGTA for final approval

Approved by:

Prepared by:	Reviewed by:	Approved by:
Continuing Airworthiness Manager	Quality Manager	Directorate General Technical Airworthiness
		
ZATY NADHIRA BINTI MOHAMED ZUHARI Continuing Airworthiness Management Manager Galaxy Aerospace (M) Sdn Bhd (1040262-D)	OMAR BIN AHMAD Quality Assurance Manager Galaxy Aerospace (M) Sdn. Bhd (1040262-D)	MOHD ZUHARRIS FIKRI BIN ISHAK Lt Kdr TLDM (N/104350) PS 2 NWSR Directorate General Technical Airworthiness
Date: 28 JUL 2023	Date: 28 JUL 2023	Date: 15 Sep 23





Issue No.	1
Revision No.	0

CAME Part	CAME Chapter	Page No.	Issue No.	Revision	Date
4	4.7	8	1	0	21 June 2023
	4.8	9	1	0	21 June 2023
4B	4B.1	1	1	0	21 June 2023
5	5.1	1 – 10	1	0	21 June 2023
	5.2	11	1	0	21 June 2023
	5.3	12	1	0	21 June 2023
	5.4	13	1	0	21 June 2023
	5.5	14	1	0	21 June 2023
	5.6	15 – 20	1	0	21 June 2023
	5.7	21	1	0	21 June 2023
	5.8	22 – 26	1	0	21 June 2023
	5.9	27 – 33	1	0	21 June 2023

The revised CAME had been internally reviewed for submission to DGTA for final approval		Approved by:
Prepared by:	Reviewed by:	
Continuing Airworthiness Manager	Quality Manager	Directorate General Technical Airworthiness
 ZATY NADHIRA BINTI MOHAMAD ZUHARI Continuing Airworthiness Management Manager Galaxy Aerospace (M) Sdn Bhd (1040262-D)	 OMAR BIN AHMAD Quality Assurance Manager Galaxy Aerospace (M) Sdn Bhd (1040262-D)	 MOHD ZULHARRIS FIKRI BIN ISHAK Lt Kdr TLDM (N/404350) PS 2 NWSP Directorate General Technical Airworthiness
Date: 28 JUL 2023	Date: 28 JUL 2023	Date: 15 Sep 23





## V. DISTRIBUTION LIST

- 1) This Continuing Airworthiness Management Exposition and any subsequent revision are distributed to the following recipients. Controlled copy holders will receive future revisions and issues. Holder of the controlled copy will ensure that the copy is maintained up to date and is made available to the concerned staff/manager/executive of the department as and when required.
- 2) The original copy of the CAME (MASTER) are held by QM GAM-CAMO and DGTA. Remaining copies are listed as per below:

COPY NUMBER	HOLDER	LOCATION	FORMAT
GAM/DGTA/CAME/MASTER1	Quality Manager GAM-CAMO	GAM OC, Subang	Paper
GAM/DGTA/CAME/MASTER2	Directorate General Technical Airworthiness	DGTA, Subang	Paper
GAM/DGTA/CAME/01	Continuing Airworthiness Manager GAM-CAMO	GAM OC, Subang	Paper
GAM/DGTA/CAME/02	Deputy Continuing Airworthiness Manager	SUMS CAMO Office	Paper
GAM/DGTA/CAME/03	CAMO Publication	Galaxy Aerospace Management System (GAMS) portal	Electronic Copy

- 3) Each holder of GAM CAME is personally responsible for the insertion of all revisions. All responsible persons shall have a thorough knowledge with the GAM CAME.
- 4) Copies are issued to any other agency other than reflected in distribution list or any personnel are considered as un-controlled. These manuals shall be current issue and revision. Un-controlled copy holder will not receive future revisions.

## VI. ABBREVIATIONS LIST

AC	Airworthiness Certificate
AD	Airworthiness Directive
ADD	Acceptable Deferred Defect
AEO	Authorised Engineering Organisation
AFM	Aircraft Flight Manual
AM	Accountable Manager
AMOC	Acceptable Means of Compliance
AMO	Approved Maintenance Organisation
AMP	Aircraft Maintenance Programme
AOG	Aircraft on Ground
AOL	Aircraft Operating Limit
ATL	Aircraft Technical Log
C of A	Certificate of Airworthiness
CAM	Continuing Airworthiness Manager
CAME	Continuing Airworthiness Management Exposition
CAMO	Continuing Airworthiness Management Organisation
CAMS	Continuing Airworthiness Management System
CDCCL	Critical Design Configuration Control Limitations
CDL	Configuration Deviation List
CMR	Certification Maintenance Requirements
CRS	Certificate of Release to Service
DAR	Design Acceptance Representative
DGTA	Directorate General Technical Airworthiness
EASA	European Aviation Safety Agency
ELT	Emergency Locator Transmitter
FC	Functional Check
GAM	Galaxy Aerospace (M) Sdn. Bhd.
GAM OC	GAM Operation Centre
GAMS	Galaxy Aerospace Management System
Leonardo S.p.A	Leonardo Societa' per Azioni
LLP	Life limited Parts
LOEP	List of Effective Pages
MEL	Minimum Equipment List
MOC	Management of Change
MM	Maintenance Manual

MMEL	Master Minimum Equipment List
MPD	Maintenance Planning Document
MRB	Maintenance Review Board
MSTC	Malaysian State Type Certificate
OEM	Original Equipment Manufacturer
OR	Occurrence Report
PIC	Pilot in Command
PIREP	Pilot Report
PTF	Permit to Fly
QM	Quality Manager
RTB	Rotor Track and Balance
SAO	State Aircraft Operator
SB	Service Bulletin
SIL	Service Instruction Leaflet
SL	Service Letter
SMI	Scheduled Maintenance Inspection
SRM	Structure Repair Manual
STC	Supplemental Type Certificate
SUMS	Stesen Udara Maritim Subang
TC	Type Certificate
TCDS	Type Certificate Data Sheet
TIC	Technical Instruction Compliance
WBR	Weight and Balance Report
WE	Weighing Engineer



## **PART 0 GENERAL ORGANISATION**

### **0.1. Corporate Commitment by the Accountable Manager**

#### **GALAXY AEROSPACE (M) SDN. BHD.**

#### **CONTINUING AIRWORTHINESS MANAGEMENT EXPOSITION**

This Exposition defines the organisation and procedures upon which the Directorate General Technical Airworthiness (DGTA) TAO-M Subpart G continuing airworthiness management approval is based.

These procedures are approved by the undersigned and must be complied with, as applicable, in order to ensure that all the continuing airworthiness tasks of Malaysia Maritime Enforcement Agency (MMEA) fleet of aircraft and/or of all aircraft under contract/tasking in accordance with TAO-M M.A.201(k) with Galaxy Aerospace (M) Sdn. Bhd. is carried out on time and to an approved standard.

It is accepted that these procedures do not override the necessity of complying with any new or amended regulation published by the DGTA from time to time where these new or amended regulations conflict with these procedures.

It is understood that the DGTA will approve this organisation whilst the DGTA is satisfied that the procedures are being followed and the work standard is maintained. It is further understood that the DGTA reserves the right to suspend, limit or revoke the TAO-M Subpart G continuing airworthiness management approval of the organisation, if the DGTA has evidence that procedures are not followed and the standards are not upheld.

I hereby confirm that the organisation will be given the necessary means to follow the rules and procedures established within these publications and that all charges are paid, as prescribed by the DGTA in respect of approved TAO-M Subpart G Continuing Airworthiness Management approval or contracts and procedures between GAM CAMO and the contracted operator.

**Dato' Shamsul Kamar Bin Samsudin**

Accountable Manager

Galaxy Aerospace (M) Sdn. Bhd.

## 0.1.1. General Information

### 0.1. A. Brief Description of the Organisation

- 1) GAM CAMO is structured under the management of the Accountable Manager. A Quality System is established which works independently and monitors all activities on the continuing airworthiness management system to ensure that it remains in conformity with the applicable TAO-M requirements. For the complete management structure refer to the organisation's management chart in Chapter 0.3 of this CAME.
- 2) GAM CAMO is an approved organisation performing Part M Subpart G for aircraft as listed on the approval certificate.

### 0.1. B. Relationship with Other Organisation

- 1) GAM CAMO currently operates independently and wholly owned by Galaxy Aerospace (M) Sdn. Bhd. (GAM).
- 2) GAM is also an independent DGTA Approved Maintenance Organisation (AMO) performing contracted maintenance, repairs and overhaul activities and DGTA Authorised Engineering Organisation (AEO).
- 3) GAM CAMO utilises GAM AMO as maintenance provider to meet the requirements of TAO-M and also supported by other DGTA Part 145 AMO to ensure that the aircraft managed are always within the controlled environment.
- 4) The details of organisation involved with GAM CAMO in delivering continuing airworthiness and/or maintenance of the aircraft and its components is as follows:

No.	Aircraft Owner / Operator	Aircraft Type	Contract Reference
1.	Malaysian Maritime Enforcement Agency (MMEA)	AW139	KDN/PL/T/APMM/4/2021
		AS365N3	KDN/PL/T/APMM/1/2022

- 5) The contract / arrangement shall be made between GAM CAMO and Operating Organisation and should define the obligations of the signatories in relation to the management of the continuing airworthiness of the aircraft as per TAO-M AMC M.A.201(k). Refer CAME Chapter 5.7 on the agreement.



## 0.1. C. Aircraft Managed – Fleet Composition

### 0.1.C.1. Quote Aircraft Types / Series

- 1) The scope of work for GAM CAMO Continuing Airworthiness Management are based on DGTA approval under TAO-M are as per below:

No.	Rating
1.	Leonardo AW139 (PWC PT6C engines)
2.	Airbus Helicopters AS365N3 (Safran Helicopter Engines Arriel 2C engines)

### 0.1.C.2. Date Included in the Scope of Work

- 1) The date for the scope of work for GAM CAMO Continuing Airworthiness Management included in DGTA approval under TAO-M are as per below:

No.	Date Included	Rating
1.	Refer DGTA TAO-M Approval Certificate	Leonardo AW139 (PWC PT6C engines)
2.		Airbus Helicopters AS365N3 (Safran Helicopter Engines Arriel 2C engines)

### 0.1.C.3. List of Aircraft Maintenance Programmes

- 1) The list of aircraft maintenance programmes managed by CAMO are as listed below:

No.	AMP Reference No.
1.	MMEA/CAMO/AMP/AW139
2.	MMEA/CAMO/AMP/AS365N3

### 0.1.C.4. List of Generic and Baseline Maintenance Programmes

- 1) There is no generic maintenance programme developed and maintained by GAM CAMO.
- 2) The maintenance programme developed by GAM CAMO are specific to aircraft configuration in accordance with the manufacturer's maintenance planning document. Refer to individual AMP for the list of basic documents for the development of the AMP.

### 0.1.C.5. The Number of Aircraft and Registration of Each Type

No.	Aircraft Owner / Operator	Aircraft Manufacturer	Aircraft Type	Aircraft Serial No.	Aircraft Reg. No.
1.	Malaysian Maritime Enforcement Agency (MMEA)	Leonardo S.p.A.	AW139	31307	M72-01
2.				31315	M72-02
3.				31316	M72-03
4.		Airbus Helicopters	AS365N3	6723	M70-01
5.				6737	M70-02
6.				6741	M70-03

### 0.1. D. Type of Operation

- 1) GAM CAMO is orientated to manage aircraft that perform the military operations as listed below:
  - a) maritime Surveillance;
  - b) Search and Rescue (SAR);
  - c) pilot / aircrew training;
  - d) transportation (personnel / cargo).

## 0.2. Management Personnel

### 0.2.0. General

- 1) The management personnel are nominated persons that are required to fill out TAO-M Form 4 and subjected to acceptance by Directorate General Technical Airworthiness (DGTA).
- 2) The current management personnel for GAM CAMO are as per table below:

Position	Nominated Personnel
Accountable Manager	Dato' Shamsul Kamar Bin Samsudin
Continuing Airworthiness Manager	Zaty Nadhira Binti Mohamed Zuhari
Quality Manager	Omar Bin Ahmad

#### 0.2. A. Accountable Manager (AM)

- 1) The Accountable Manager (AM) has corporate authority for ensuring that all continuing airworthiness activities can be resourced and carried out in accordance with TAO-M.
- 2) The duties and responsibilities associated with this post are stated in paragraph 0.2.D.1) of this CAME.

#### 0.2. B. Continuing Airworthiness Manager (CAM)

- 1) The Continuing Airworthiness Manager (CAM) is responsible for ensuring that all maintenance is carried out on time to an approved standard.
- 2) The CAM is responsible for the management and supervision of continuing airworthiness management activities and shall be responsible to the AM.
- 3) The duties and responsibilities associated with the post of CAM are as stated in paragraph 0.2.D.2) of this CAME.

#### 0.2. C. Continuing Airworthiness Coordination

- 1) The CAM is supported by a group of personnel to ensure that GAM CAMO is always in compliance with TAO-M. These consists of personnel for Deputy



CAM, CAMO Planner, Technical Records, Technical Publication and Technical Service.

- 2) The Deputy CAM is responsible to assist CAM with day-to-day activities as per CAME paragraph 0.2.D.2).
- 3) Technical Publication personnel is responsible for maintaining and updating the master set of technical documents, and applicable manuals used for the continuing airworthiness of aircraft managed by GAM CAMO.
- 4) Technical Record personnel is responsible manage, update, and archive all continuing airworthiness records.
- 5) CAMO Planner personnel is responsible to coordinate scheduled maintenance, the accomplishment of airworthiness directives, the replacement of service life limited parts, and component inspection to ensure the work is carried out properly.
- 6) Technical Service personnel is responsible to provide technical service support, prepare technical documents and review Airworthiness Directives and Service Bulletin.
- 7) The duties and responsibilities of CAMO personnel are as stated in paragraph 0.2.D.4) of this CAME.

### **0.2.C.1. Deputy to Nominated Persons**

- 1) GAM CAMO shall ensure that the organisation remain in compliance with TAO-M regulation even during absence of the nominated persons.
- 2) Directorate General Technical Airworthiness (DGTA) shall be informed accordingly for absence of the nominated persons longer than one month and having deputy to assume such responsibility. The deputy is required filling out TAO-M Form 4 and subjected to acceptance by DGTA.
- 3) The deputy shall be able to show sufficient knowledge, background and appropriate experience related to aircraft continuing airworthiness to the satisfaction of DGTA equivalent to the nominated persons.

- 4) Refer table below for the names of deputies to the nominated persons:

Position	Nominated Deputy
Accountable Manager	-
Continuing Airworthiness Manager	Mohd Shazalie bin Ramli
Quality Manager	Shall be assumed by Accountable Manager

## 0.2. D. Duties and Responsibilities

### 0.2.D.1. Accountable Manager

- 1) The Accountable Manager (AM) has corporate authority for ensuring that all continuing airworthiness management activities can be financed and carried out in accordance with TAO-M M.A. Subpart G.
- 2) The AM is responsible for:
  - a) ensuring that all necessary resources are available to manage continuing airworthiness in accordance with TAO-M M.A. Subpart G to support the organisation approval certificate;
  - b) nominating a person or group of persons with the responsibility of ensuring that the organisation always complies with the applicable continuing airworthiness management, airworthiness review and permit to fly requirements of DGTA TAO-M;
  - c) nominating a person or group of persons with the responsibility for managing the compliance monitoring function as part of the management system; and
  - d) ensuring that the nominated persons have a direct reporting line to the AM to ensure that the AM is kept properly informed on quality and compliance matters.

### 0.2.D.2. Continuing Airworthiness Manager

- 1) The nominated post holder for continuing airworthiness will ensure that all maintenance is carried out by the DGTA Approved Maintenance Organisation, in accordance with the relevant approved maintenance programme, on time

and to an approved standard. For every aircraft managed by GAM CAMO, the CAM has the following responsibilities:

- a) develop and control a maintenance programme for the aircraft managed including any applicable reliability programme;
- b) present the aircraft maintenance programme and its amendments to DGTA for approval, unless covered by an indirect approval procedures;
- c) manage the accomplishment of modification and repairs;
- d) ensure that all maintenance is carried out in accordance with the AMP and released in accordance with M.A. 801 – Certificate of Release to Service (CRS);
- e) ensure that all applicable Airworthiness Directives and operational directives with a continuing airworthiness impact are applied;
- f) ensure that all defects discovered or reported are managed appropriately until corrected by a DGTA AMO;
- g) ensure that maintenance is only carried out by a DGTA AMO;
- h) coordinate scheduled maintenance, the application of Airworthiness Directives, the replacement of service life limited parts, and component inspection to ensure the work is carried out properly;
- i) manage and archive all continuing airworthiness records;
- j) ensure that the weight and balance statement reflect the current status of the aircraft;
- k) ensure the symmetry check statement reflects the current status of the aircraft (if applicable).

### **0.2.D.3. Quality Manager (QM)**

- 1) The Quality Manager is responsible for the following functions:
  - a) monitoring that all activities carried out under TAO-M M.A. Subpart G are being performed in accordance with the approved procedures;



- b) monitoring that all contracted maintenance is carried out in accordance with the contract;
- c) monitoring the continued compliance with the requirements of TAO-M M.A. Subpart G;
- d) monitoring that all subcontracted continuing airworthiness management tasks is carried out in accordance with the contractual obligations;
- e) monitoring and amending of the CAME and the submission of proposed amendments to DGTA;
- f) establishing and managing the corrective action process, including root cause analysis and identification of preventative measures;
- g) liason with DGTA regarding compliance and auditing;
- h) establishing a compliance monitoring feedback system in accordance with Chapter 5 of TAO-M M.A. SUBPART G; and
- i) initiate and coordinate any necessary actions and follow-up activity highlighted by an occurrence report.

#### **0.2.D.4. CAMO Personnel**

##### **0.2.D.4.1. Deputy CAM**

- 1) Assist CAM with day-to day activities as per paragraph 0.2.D.2 above.
- 2) Assist in review and closure of internal and external audits.
- 3) Control, manage and develop internal procedure.

##### **0.2.D.4.2. CAMO Planner**

- 1) Raise Work Pack for every confirmed Work Order.
- 2) Gather and consolidate maintenance and inspection requirement for a maintenance or workshop work, as per approved maintenance programme requirement.
- 3) Gather and advise customer of any additional requirement especially Airworthiness Directives or Service Bulletins.



Issue No.	1
Revision No.	0

- 4) Register the Workpack and Worksheets raised.
- 5) Prepare Workpack and associated Worksheets and consult TAO-145 AMO to verify scope and content of the Workpack.
- 6) Liaise with TAO-145 AMO of aircraft maintenance downtime or period needed to complete a particular maintenance or workshop task.
- 7) Prepare Daily Maintenance Report which is to be made available to CAM Manager, TAO-145 AMO and Operator on every maintenance or workshop task.
- 8) Ensure all parts used on aircraft or a workshop task are recorded in the worksheet.
- 9) To assist TAO-145 AMO organising all outstanding parts for a maintenance or workshop task.
- 10) To compile, check and acceptance of all completed Workpack and Worksheets are accounted for, completed and duly signed. For Scheduled Inspections, ensure the Certificate of Release to Service duly signed.

#### **0.2.D.4.3. Technical Publication**

- 1) Procure and administer all airworthiness and operational data/instruction/documents required for continuing airworthiness and maintenance activities according to the scope of work available for the organisation.
- 2) Maintain a technical library to keep master copy of all required publications.
- 3) Establish an effective system to replicate and distribute all required information /documents distributed to the relevant recipient.
- 4) Establish and maintain a register of all airworthiness and operational data / instruction / documents acquired and distributed including their location and status.
- 5) The focal point to receive report for publication discrepancy.



#### **0.2.D.4.4. Technical Records**

- 1) Procure maintain and manage any records associated with the maintenance management or operation such as aircraft logbooks, aircraft workpack/worksheet, etc.;
- 2) liaison with Maintenance Planning and Part 145 AMO in particular in respect of component configuration and status;
- 3) support the performance of Airworthiness Reviews (ARR) process to ensure correct availability of back to birth records for Continuing Airworthiness;
- 4) importation and Exportation of Aircraft Technical Records as required;
- 5) perform QC Data checks of the various information's which managed by the Technical records office and resolve any ambiguities, technical or other problems from Engineering, Operations and Crew.

#### **0.2.D.4.5. Technical Service**

- 1) Procure check maintenance data applicability to aircraft type or components, serial number.
- 2) Prepare aircraft weight and balance report.
- 3) Provide engineering and technical support.
- 4) Produce used aircraft report for the application of certificate of airworthiness.
- 5) Prepare airworthiness flight test schedule.
- 6) Liaison with DGTA and other airworthiness authorities, AEO and OEM in the scope of Technical Services.
- 7) To perform and monitor the reliability program to improves aircraft, power plants, and/or systems reliability through data collection, analysis, corrective action, and follow-up.



## **0.2. E. Manpower Resources and Training Policy**

### **0.2.E.1. Manpower Resources**

- 1) GAM CAMO must always employ sufficient appropriate staff to ensure the expected work can be performed and all duties can be fulfilled. The minimum number of employees dedicated to the performance of the continuing airworthiness management systems must be employed.
- 2) GAM CAMO Manpower Resources and Management Tools in CAME Chapter 5.9 is used to ensure that the staff are sufficient to perform the airworthiness management activities. The automation manpower management tool is used to show the balance ratio of manpower to tasks and its sufficiency.
- 3) The manpower resources calculation shall be reviewed annually or whenever there is any significant changes to the number of aircraft managed by GAM CAMO that may affect the manpower calculation.

### **0.2.E.2. Training Policy**

- 1) Training will be provided by GAM CAMO to ensure that each member of staff is adequately trained to carry out the functions of, and satisfy the responsibilities associated with, the TAO-M M.A. Subpart G continuing airworthiness management functions.
- 2) CAM shall review training needs at intervals not exceeding two years or at more frequent intervals taking into account of changes in:
  - a) regulations;
  - b) CAME / company procedures;
  - c) new aircraft type;
  - d) organisation.
- 3) The staff member shall be made aware of how these changes affect their duties and responsibilities and the company procedures. Continuation Training consists of procedures, regulation, and technical training.

- 4) It's the responsibility of CAM that each training is documented and that the training recordings are stored in the personal files required for each nominated persons for at least two years after the relevant nominated persons has left.
- 5) The type of training that is required for all CAMO personnel are listed in the following table:

No	Course	Position									Remarks	
		AM	QM	QA	CAM	Deputy CAM	Technical	CAMO Planner	Technical	Technical Publication	Initial	Continuous (Every 2 Years)
<b>O – Optional</b>						<b>M - Mandatory</b>						
<b>*M – Mandatory courses conducted by DGTA</b>												
1	TAO-M – Continuing Airworthiness Management	O	*M	*M	*M	*M	M	M	M	M	/	
2	DGTA Continuing Airworthiness Management Exposition (CAME)	O	M	M	M	M	M	M	M	M	/	/
3	Quality Procedure Manual (QPM)	O	M	M	O	O	O	O	O	O	/	/
4	Human Factor	M	M	M	M	M	M	M	M	M	/	/
5	Safety Management System	M	M	M	M	M	M	M	M	M	/	/
6	AERONET System	O	O	M	M	M	M	M	M	M	/	
7	Aircraft /Component Type Training	O	O	O	O	O	O	O	O	O	/	
8	Aircraft General Familiarisation	O	O	O	M	M	O	O	O	O	/	

No	Course	Position									Remarks	
		AM	QM	QA	CAM	Deputy CAM	Technical	CAMO Planner	Technical	Technical	Initial	Continuous (Every 2 Years)
O – Optional						M - Mandatory						
<b>*M – Mandatory courses conducted by DGTA</b>												
10	Audit Technique/Lead Auditor Course	O	M	M	O	O	O	O	O	O	/	
11	Root Course Analysis	O	M	M	M	M	O	O	O	O	/	

- 6) Initial training is provided to ensure that all personnel are equipped with the basic knowledge, skills, and experience to enable them to perform continuing airworthiness management on aircraft.
- 7) Continuous training is also required to ensure that all personnel are continuously trained to familiarise on changes with the DGTA regulations, organisation procedures and/or the aircraft types managed by GAM CAMO. The frequency of the continuous training shall be within two years interval.

**0.3. Management Organisation Charts**

**0.3.1. General Organisation Chart**

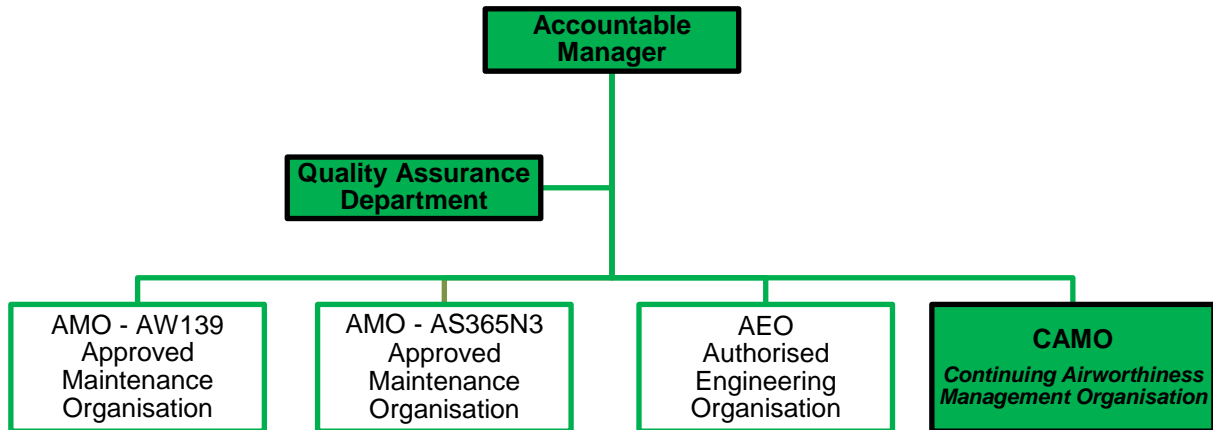

**0.3.2. Continuing Airworthiness Management Organisation Chart**

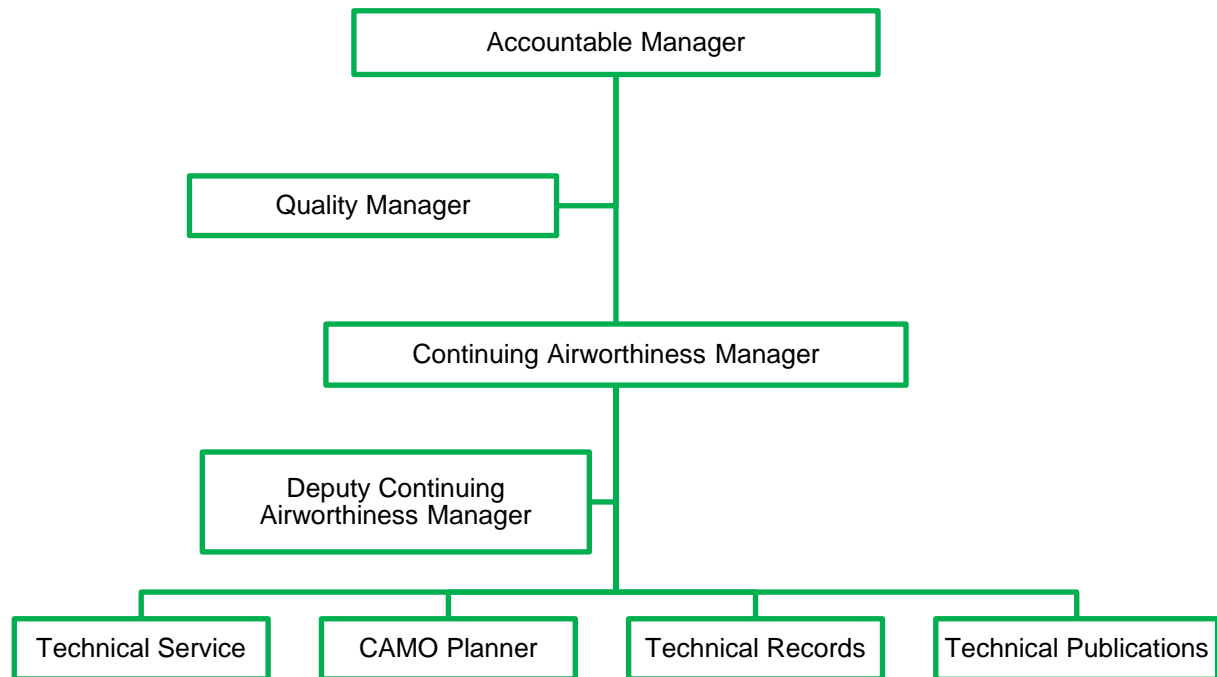

#### **0.4. Notification Procedure to the DGTA Regarding Changes to the Organisation's Activities / Approval / Location / Personnel**

##### **0.4. A. Changes**

- 1) Any changes in GAM CAMO shall be notified to DGTA by the Accountable Manager (or any delegated person such as the Continuing Airworthiness Manager or the Quality Manager). This is to enable DGTA to determine continued compliance with DGTA TAO-M and to approve the changes prior to incorporation or make any necessary amendments.
- 2) The following significant changes shall be notified to DGTA:
  - a) the name of the CAMO;
  - b) the location of the CAMO;
  - c) additional locations of the CAMO;
  - d) the Accountable Manager;
  - e) any of the persons specified in Chapter 0.2;
  - f) the facilities, procedures, work scope and staff that could affect the approval;
  - g) any changes that affect the approval certificate.

##### **0.4. B. Notification Before Such Changes Take Place**

- 1) Any aforementioned changes shall be notified to DGTA before its implementation and such changes will not be incorporated until they have been assessed and approved by the DGTA.

##### **0.4. C. Conduct a Risk Assessment for Any Change Requiring Prior Approval and Provide it to DGTA Upon Request**

- 1) Risk assessment shall be conducted for any changes requiring prior approval and provide it to DGTA upon request.

	<b>Continuing Airworthiness Management Exposition (CAME)</b>	
	Issue No.	<b>1</b>
	Revision No.	<b>0</b>

**0.4. D. Internal Pre-Audit Before Application**

- 1) Quality Department shall conduct internal pre-audit prior application to DGTA confirming that processes, facilities, documentation, and personnel subject to the application have been reviewed showing compliance with all applicable DGTA requirements. The relevant internal audit report(s) including the associated corrective actions shall be provided to DGTA.



## **0.5. CAME Amendment Procedure**

### **0.5.1. General**

- 1) It is necessary to comply with any new or amended regulation published by the DGTA from time to time. New or amended procedures should not be in conflict with the regulation. Regulation changes as well as any relevant changes within the GAM CAMO that affect the approved CAME therefore call for an amendment thereof.
- 2) The CAM is responsible for the amendments of the exposition to comply with all DGTA regulations and proposed to QM. The QM shall monitor all applicable regulations and shall incorporate all changes which affect GAM CAMO.
- 3) The amendment of CAME are divided into two amendment procedures:
  - a) direct amendments - amendments that need prior approval from DGTA.
  - b) indirect amendments - amendments not requiring prior approval from DGTA.

### **0.5. A. Amendments That Need Prior Approval**

- 1) Amendments that need prior approval is also known as Direct Amendments.
- 2) Direct amendments shall be approved by DGTA.
- 3) The CAM shall provide the amendment to QM in order to monitor conformity with requirements and consistency to the procedures. All direct amendments of the CAME shall be submitted by QM to DGTA for approval after internal acceptance.

### **0.5. B. Amendments Not Requiring Prior Approval**

- 1) Amendments that not requiring prior approval is also known as indirect amendments.
- 2) The indirect amendment shall be proposed by the CAM and sent to the QM in order to monitor conformity with DGTA requirements and consistency with the procedures.
- 3) Indirect amendments do not required approval from DGTA. QM will be delegated for indirect approval.





Issue No.	1
Revision No.	0

### **0.5. C. Description of How Such Amendments Will Be Managed**

- 1) Amended text passages must be marked with a vertical line at the left side of the page and highlighting the revised portion of the text.
- 2) The Revision numbering system is organized as follows: GAM/DGTA/CAME Issue number, Revision number (Direct) (Indirect, if applicable) where:
  - a) Issue number: numeric numbering; increased for major changes in the CAME.
  - b) Revision number:
    - (1) Direct Amendment – numeric numbering; increased at every direct amendment; set to 0 at every increase of issue number.
    - (2) Indirect Amendment – alpha-numeric numbering; increased at every indirect amendment; reset at every increase of direct amendment number.

### **0.5. D. The Person is Responsible for Amending the Exposition**

- 1) CAM is responsible for the amendment of the exposition, including associated procedure manuals and the submission of proposed amendments to the DGTA.

### **0.5. E. Sources of Proposed Amendments Within the Organisation**

- 1) The proposed amendments to the CAME within the organisation shall be submitted to QM via Management of Change (MOC) form.

### **0.5. F. Internal Approval Process**

- 1) For indirect amendments, QM shall verify and validate the amended procedures accordingly and to ensure the amended procedures are in compliance with DGTA requirements / regulations.
- 2) After verifying and validating, QM shall signed on the QM Approval column of the Indirect Amendments under the Amendment Record page of the CAME.

### **0.5. G. The Approval Process with DGTA**

- 1) After received the proposed amendments form CAM, QM will review and verify the amended procedures to be in compliance with DGTA requirements.
- 2) CAM and QM shall signed the LOEP once reviewed and finalised as internal approval prior submission to DGTA for approval. The revision and date of the appropriate pages and in the List of Effective Pages (LOEP) has to be changed.
- 3) Once approved by the DGTA, the revision must be added to the exposition by replacing the old pages. At the bottom of each page for List of Effective Pages (LOEP) a Date / Name / Signature column for (Prepared by CAM), for (Reviewed by QM) and for (Approved by DGTA) shall be available.

### **0.5. H. Revision Acknowledges Receipt Process**

- 1) The effective date of the revision is stated on the respective column of the Record of Revision table. The revision pages must be distributed to the recipients according to the distribution list.
- 2) The staffs must be advised about the changes.

### **0.5. I. Definition of Minor Amendments to the Exposition That Can Be Amended Without the Prior Approval of the DGTA**

- 1) The following changes in the exposition are considered as minor amendments (also known as indirect amendments):
  - a) change of increasing manpower resources, except for management personnel requiring DGTA Form 4.
  - b) editorial changes.
  - c) changes of forms listed in Chapter 5.1.
- 2) All amendments not covered by paragraph above shall be considered as major amendments (also known as direct amendments).

### **0.5. J. Summary of Documents, Including ‘Lower Order’ Documents, Constituting the Total Exposition**

- 1) GAM CAMO documents comprise as follows:



- a) First level document
  - (1) Continuing Airworthiness Management Exposition (CAME) ref. GAM/DGTA/CAME
- b) Notices
  - (1) Continuing Airworthiness Notice (CAN)
  - (2) Quality Assurance Notice (QAN)

#### **0.5. K. The Effective Date of the Amendment**

- 1) After DGTA has approved the amendments, the date when the amendments will take effect is two (2) weeks from the date of approval. This is to allow time to train personnel, print forms and / or distribute the revision, so all personnel required at different locations have received the revision at the date it is effective.

#### **0.5. L. CAME Review**

- 1) The CAME shall be subject to periodic review, not exceeding one year, and amended as necessary to ensure that the CAME remain relevant, appropriated for the organisation, and comply with any amendment of the applicable DGTA regulations.
- 2) The participants for the CAME review shall consist of at least the following:
  - 1) CAM or his/her delegate; and
  - 2) QM or his/her delegate
- 3) The review meeting shall be documented and any required amendments to the CAME arising from the meeting shall be included. The amended CAME shall be submitted to QM via MOC.

## **PART 1 CONTINUING AIRWORTHINESS MANAGEMENT PROCEDURES**

### **1.1. Utilisation of Aircraft Continuing Airworthiness Record System and Aircraft Technical Log and MEL and/or CDL**

#### **1.1.A. Aircraft Technical Log and Continuing Airworthiness Record System**

##### **1.1.A.1. General**

- 1) Aircraft technical log is a system for recording defects and malfunctions during the aircraft operation and for recording details of all maintenance carried out on an aircraft between scheduled base maintenance visits. In addition, it is used for recording flight safety and maintenance information the operating crew need to know.
- 2) GAM CAMO shall use an aircraft technical log system containing the following information for each aircraft:
  - a) information about each flight, necessary to ensure continued flight safety;
  - b) the current aircraft Certificate of Release to Service or equivalent;
  - c) the current maintenance statement giving the aircraft maintenance status of what scheduled and out of phase maintenance is next due except that the DGTA should agree to the maintenance statement being kept elsewhere;
  - d) all outstanding deferred defects rectifications that affect the operation of the aircraft.
- 3) In the event that unscheduled maintenance and/or defect rectification is required to be carried out away from main base, by another maintenance organisation, the prior agreement of the primary maintenance contractor must be sought. The organization carrying out such maintenance will be required to issue a CRS in the Technical Log and details of work carried out shall be sent to operator as soon as practicable.
- 4) While the CAM is responsible for maintaining and completing the continuing airworthiness record system, the ATL is completed by the owner or operator's



pilots. It shall always be carried on board. GAM CAMO must be informed in regular intervals about the current running total flying hours of the aircraft by the owner/operator for planning the next maintenance event.

### **1.1.A.2. Instruction For Use**

- 1) All entries to the Aircraft Technical Log (ATL) system must comply with the following conditions:
  - a) be writing in indelible ink;
  - b) all input must be in the English Language;
  - c) be clear, concise and use block capitals;
  - d) all pages of log book must be legible.
- 2) The instructions to fill each ATL shall be referred to ATL Instruction for Use in GAMS portal.

### **1.1.A.3. Aircraft Technical Log Approval**

- 1) The aircraft technical log system and any subsequent amendment shall be incorporated in the CAME and approved by DGTA. The previously approved ATL may be fully utilised prior using the new revision of the ATL.

### **1.1.A.4. The Records System**

- 1) The ATL comprise of a single section document in paper format containing the information in paragraph 1.1.A.1.2) above. The ATL shall have at least 3 copies for each page. First copy will be held by GAM CAMO. Second copy will be held by Operator. Third copy is the Logbook copy. Fourth Copy may be used as standby copy which to be retained on the ground until completion of the flight to which it relates. Else, a digital copy of the ATL is required to be sent to CAMO prior to take off.
- 2) The ATL shall be scanned as a backup and stored in a safe way with regard to damage, alteration, and theft.
- 3) GAM CAMO shall retain the ATL for at least 36 months after the date of the last entry.
- 4) The ATL records are kept accessible within a reasonable time whenever they are needed.

- 5) These ATL are filed and organised by aircraft serial no. and registration to ensures their traceability and retrievability throughout the required retention period of all activities developed.

### **1.1.B. Minimum Equipment List (MEL) and/or Configuration Deviation List (CDL) Utilisation**

#### **1.1.B.0 General**

- 1) The minimum equipment list (MEL) is intended to permit operations with certain inoperative items of equipment for the minimum period necessary until repairs can be accomplished. It is important that repairs are accomplished at the earliest opportunity in order to return the aircraft to its design level of safety and reliability.
- 2) GAM CAMO shall establish, at the customer request and where possible, for each aircraft a Minimum Equipment List (MEL) and submit for approval to the DAR.
- 3) This shall be based upon, but not be less restrictive than, the relevant Master Minimum Equipment List (MMEL) if this exists, and other applicable requirements accepted or mandated by the DGTA.
- 4) A revision to the MMEL, will require to review and amend the MEL, as necessary. Where a source MMEL revision is more restrictive, GAM CAMO shall submit an appropriate amendment to the MEL for approval immediately on receipt of the MMEL revision.
- 5) The time for MEL amendment is 120 days for MMEL revision that does not affect a procedure ((M) or (O) and where the MMEL revision affects a procedure, the MEL amendment time is 60 days.
- 6) The MEL shall be reviewed at least annually to ensure that it incorporates any changes to the operation, aircraft or to the regulation.

### 1.1.B.1 MEL/CDL Categories

- 1) The maximum time an aircraft may be operated between the discovery of an inoperative item and its repair will be specified in the MMEL. Passenger convenience items such as reading lights may have no specified repair interval (no category).
- 2) The category of all other inoperative items will be determined according to the time intervals specified below:
  - a) Category A – Items in this category shall be repaired within the time interval specified in the “Remarks or Exceptions” column of GAM approved MEL. Whenever the proviso in the “Remarks or Exceptions” column of the MMEL states cycles or flight time, the time interval begins with the next flight.
  - b) Category B – Items in this category shall be repaired within 3 consecutive calendar days excluding the day of discovery.
  - c) Category C – Items in this category shall be repaired within 10 consecutive calendar days, excluding the day of discovery.
  - d) Category D – Items in this category shall be repaired within 120 consecutive calendar days, excluding the day of discovery. To be considered for placement in Category D, the item must be of an optional nature, or excess equipment.
- 3) To be approved for Category D, the item must meet the following criteria:
  - a) the absence of the item does not affect crew workload;
  - b) the pilots do not rely on the function of that item on a routine or continuous basis; and
  - c) the pilot’s training, subsequent habit patterns and procedures do not rely on the use of that item.

### 1.1.B.2 Utilisation

- 1) When an item of equipment is discovered to be inoperative, it is reported by making an entry in ATL and Deferred Defect Record.

- 2) When a defect has been raised in 'Defects' column of the ATL and is deemed to be within the allowance quoted in the MEL, then it may be subject to deferred defect action.
- 3) When operating with multiple inoperative items, the interrelationship between those items and the effect on aircraft operation and crew workload will be considered.

### **1.1.B.3 Acceptance by the Aircraft Commander**

- 1) The requirement of the MEL will only be applied following the agreement between the State Operator (pilot in command) and the DGTA AMO.
- 2) It is recognised that the pilot may require a defect to be rectified after considerations of operational implications, or multiple unserviceable items affecting airworthiness and/or due increase in crew workload.
- 3) Where the MEL item has been entered by maintenance personnel, the decision to accept the deferred item allowed by the MEL/CDL remains the responsibility of the pilot in command.

### **1.1.B.4 Management of the MEL/CDL Time Limits**

- 1) The deferred defect item is monitored by GAM CAMO using the CAMS for a timely rectification based on the specified repair intervals stated in the MEL.
- 2) GAM CAMO then shall coordinate with Part 145 AMO in terms of spares, personnel, facilities and schedules to ensure timely repair of the defect item.
- 3) Defect rectification cannot be postponed unless agreed by the operator and in accordance with a procedure approved by the DGTA.

### **1.1.B.5 MEL/CDL Time Limitation Overrun**

- 1) The extension of the rectification interval shall be in accordance with the operational and maintenance procedures defined in the MEL approved by DAR as applicable.
- 2) CAM shall notify DGTA for each approved extension of the rectification interval by DAR within stipulated time.





## **1.2. Aircraft Maintenance Programme (AMP)**

### **1.2.A. General**

- 1) Maintenance of each aircraft shall be organised in accordance with an approved aircraft maintenance programme. Aircraft Maintenance Programme is a document which describes or incorporates by reference the specific scheduled maintenance tasks and their frequency of completion, the associated maintenance procedures and related standard maintenance practices necessary to preserve the airworthiness of those aircraft to which it applies.
- 2) The aircraft shall only be maintained to one approved AMP at a given point in time. Where an operator wishes to change from one AMP to another, a transfer check or inspection may need to be performed in order to implement the change.
- 3) An AMP may indicate that it applies to several aircraft registrations numbers as long as the AMP identifies the effectivity of the tasks and procedures that are not applicable to all of the listed registrations.
- 4) Evaluation should be made of the aircraft/fleet utilisation, landing rate, equipment fit and, in particular, the experience of GAM CAMO when assessing an existing programme.
- 5) When DGTA is not satisfied that the proposed maintenance programme can be used as is, DGTA shall request appropriate changes such as additional maintenance tasks or de-escalation of check frequencies as necessary.

### **1.2.B. Content**

- 1) The Aircraft Maintenance Programme (AMP) should contain the following basic information in accordance with Appendix I to TAO-M AMC M.A.302(a):
  - a) the type/model and registration number of the aircraft, engines and, where applicable, auxiliary power units and propellers;
  - b) the name and address of the Operating Organisation(s) and the organisation responsible for producing and amending the AMP;
  - c) the reference, the date of issue and issue number of the AMP;

- d) a statement signed by the CAMO's Accountable Manager or their nominated representative to the effect that the specified aircraft will be maintained to the AMP and that the AMP will be reviewed and updated as required;
- e) contents/list of effective pages and their revision status of the document;
- f) intervals for scheduled maintenance reflect the anticipated utilisation of the aircraft. Such utilisation should be stated and include tolerance. Where utilisation cannot be anticipated, calendar time limits should also be included;
- g) procedures for the extension of established intervals for scheduled maintenance, where applicable and acceptable to the DGTA;
- h) provision to record the date and reference of approved amendments incorporated in the AMP;
- i) details of pre-flight tasks that are accomplished by maintenance staff;
- j) the tasks and the periods (intervals/frequencies) at which each part of the aircraft, engines, APU's, propellers, components, accessories, equipment, instruments, electrical and radio apparatus, together with the associated systems and installations should be inspected. This should include the type and degree of inspection required;
- k) the periods at which components should be checked, cleaned, lubricated, replenished, adjusted and tested;
- l) if applicable, details of ageing aircraft system requirements together with any specified sampling programmes;
- m) if applicable, details of specific structural maintenance programmes where issued by the MSTC holder / any organisation recognised by the DGTA, including but not limited to:
  - (1) Damage Tolerance based Structural Maintenance Inspection Programmes and Supplemental Structural Inspection Documents (SSID);
  - (2) structural maintenance programmes resulting from the SB review performed by the TC holder;

- (3) Corrosion Prevention and Control Programmes (CPCP);
  - (4) Repair Evaluation Guidelines, Repair Assessment Programmes or similar documents;
  - (5) Widespread Fatigue Damage.
- n) If applicable, details of CDCCLs together with appropriate procedures;
  - o) If applicable, a statement of the limit of validity in terms of total flight cycles/calendar date/flight hours / other service life consumption units for the structural programme in m) above;
  - p) The periods at which overhauls and/or replacements by new or overhauled components should be made;
  - q) A cross-reference to other documents approved by the DGTA which contain the details of maintenance tasks related to mandatory life limitations, Certification Maintenance Requirements (CMR's) and ADs;
- NOTE: To prevent inadvertent variations to such tasks or intervals these items should not be included in the main portion of the AMP document, or any planning control system, without specific identification of their mandatory status;
- r) Details of, or cross-reference to, any required reliability programme or statistical methods of continuous surveillance;
  - s) A statement that practices and procedures to satisfy the programme should be to the standards specified in the maintenance instructions promulgated by the Malaysian State Type Certificate (MSTC) and Supplementary Type Certificate (STC) holders and any other organisation that publishes such data in accordance with DGTA TAO 21. In the case of approved practices and procedures that differ, the statement should refer to them;
  - t) Each maintenance task quoted should be defined in a definition section of the AMP.

## **1.2.C. Development**

### **1.2.C.1. Sources**

- 1) An AMP should normally be based upon the maintenance review board (MRB) or equivalent report where applicable, the maintenance planning document (MPD), the relevant chapters of the maintenance manual or any other maintenance data containing information on scheduling. Furthermore, an AMP should also take into account any maintenance data containing information on scheduling for components
- 2) When the maintenance programme is based on maintenance steering group logic or on condition monitoring, the aircraft maintenance programme shall include a reliability programme.
- 3) The structure and format of these maintenance recommendations may be re-written by the owner or GAM CAMO to better suit the operation and control of the particular maintenance programme.
- 4) The aircraft maintenance programme shall be established in compliance with:
  - a) the instructions issued by DGTA;
  - b) instructions for continuing airworthiness issued by any organisation recognised by the DGTA.
  - c) additional or alternative instructions, once approved in accordance with paragraph 1.2.C.4.1), proposed by GAM CAMO, except for intervals of safety related tasks referred in paragraph 1.2.C.1.5) below, which may be extended, subject to sufficient reviews carried out in accordance with paragraph 1.2.C.3.1) and only when subject to direct approval in accordance with paragraph 1.2.C.4.1).
- 5) The aircraft maintenance programme shall contain details, including frequency of all maintenance to be carried out, including any specific tasks linked the type and the specific operations. When applicable, the aircraft maintenance programme shall include the certification maintenance requirements item.

### 1.2.C.2. Responsibilities

- 1) The SAO is responsible for development of the AMP and its amendments for all operated aircraft.
- 2) If the development of an AMP or its amendments has been contracted to GAM CAMO, the responsibility remains with the SAO. DAR shall check and verify the contents of AMP are complied with the approved manufacturer manuals before submission to DGTA.
- 3) The application and submission to DGTA for AMP approval shall be made by GAM CAMO.

### 1.2.C.3. AMP Amendments

- 1) The AMP shall be subject to periodic reviews and amended accordingly. These reviews shall ensure that the programme continues to be valid in light of the operating experience and instructions from DGTA whilst taking into account new maintenance instructions and/or modified maintenance instructions, promulgated by the type certificate and supplementary type certificate holders, any other organisation that publishes such data in accordance with TAMM Regulation 2 and Regulation 3.
- 2) The AMP details should be reviewed at least annually. As a minimum, revisions of documents affecting the AMP basis need to be considered by GAM CAMO for inclusion in the AMP during the annual review. Applicable mandatory requirements for compliance with Regulation 2 and/or Regulation 3 should be incorporated into the AMP as soon as possible.
- 3) Repetitive maintenance tasks derived from modifications and repairs should be incorporated into the AMP.
- 4) Amendments (revisions) to the AMP should be made by GAM CAMO, to reflect changes in the TC holder's recommendations, modifications, service experience, or as required by the DGTA.
- 5) Amendments shall be classified as follows:
  - a) Minor Amendments – Amendments that are made internally by CAMO and approved by QM for the following changes and conditions:

- (1) amendments due to minor editorial changes/correction of typing errors;
  - (2) amendments to include additional task cards resulting from maintenance planning document update or ICA inspections from modification embodiment;
  - (3) amendments due to changes to part numbers;
  - (4) amendments that do not result in an increase in aircraft component life / cycle or reduction in the degree/frequency of previously approved routine maintenance.
- b) Major Amendments – Any changes that do not meet the criteria above shall be considered as Major Amendments and shall require approval from DGTA.
- 6) The Revision numbering system is organized as follows: SAO/CAMO/AMP/AIRCRAFT TYPE Issue number, Revision number (Major) (Minor, if applicable) where:
- a) Issue number: numeric numbering; increased for major significant changes in the AMP
  - b) Revision number:
    - (1) Major amendment – numeric numbering; increased at every major amendment; set to 0 at every increase of issue number.
    - (2) Minor amendment – alpha-numeric numbering; increased at every minor amendment; reset at every increase of major amendment number.
- 7) The approval for Major amendments shall be made through the Maintenance Programme Approval Page of the AMP.
- 8) For Minor amendments, approval shall be made through the Record of Amendments Page under para. Minor amendments and be approved by Quality Manager.



Issue No.	1
Revision No.	0

#### **1.2.C.4. Acceptance by the DGTA**

- 1) The aircraft maintenance programme and any subsequent amendments as per paragraph 1.2.C.3.5)b) above shall be approved by DGTA.
- 2) DGTA approval is indicated in the Maintenance Programme Approval Page which is part of the AMP document.
- 3) GAM CAMO may only vary the periods prescribed by the programme with the approval of the DGTA or through a procedure developed in the maintenance programme and approved by the DGTA.



### **1.3. Usage and Continuing Airworthiness Records: Responsibilities, Retention and Access**

#### **1.3.A. Flying Hours, Flight Cycles, Landings Recording**

- 1) Flying hours, flight cycles, and landings are recorded in the Technical Log and thus supplied to GAM CAMO. GAM CAMO must be informed in regular intervals, depending on the utilisation, about the current running total flying hours and cycles of the aircraft by the owner/operator for planning the next maintenance event.
- 2) The aircraft type and registration mark, the date, together with total flight time and/or flight cycles and/or landings and any other airworthiness data as required by the DGTA as appropriate, shall be entered in the aircraft continuing airworthiness record system.

#### **1.3.B. Records**

- 1) GAM CAMO aircraft continuing airworthiness records shall consist of, as appropriate, an aircraft logbook, engine logbook(s) or engine module log cards, propeller logbook(s), log cards for any service life limited component and an aircraft technical logbook.
- 2) At the completion of any maintenance, the Certificate of Release to Service or equivalent required by relevant AMO regulations shall be entered in the aircraft continuing airworthiness record system. All maintenance performed shall be accurately and progressively documented.
- 3) The aircraft logbook shall be identified with the aircraft type and registration mark. The date together with the following information, as appropriate, shall be entered in the appropriate logbooks:
  - a) total flight time;
  - b) total flight cycles; and
  - c) total landings.
- 4) The aircraft continuing airworthiness records shall contain the current:
  - a) status of airworthiness directives and measures mandated by the DGTA in immediate reaction to a safety problem;



- b) status of modifications and repairs;
  - c) status of compliance with the AMP;
  - d) status of service life limited components;
  - e) weight and balance report;
  - f) list of deferred maintenance;
  - g) symmetry check report (if required).
- 5) In addition to the authorised release certificate, the following information relevant to any component installed (engine, propeller, engine module or service life-limited component) shall be entered into the aircraft continuing airworthiness record system:
- a) identification of the component; and
  - b) the type, serial number and registration, as appropriate, of the aircraft, engine, propeller, engine module or service life-limited component to which the particular component has been fitted, along with reference to the installation and removal of the component; and
  - c) the date together with the component's accumulated total flight time and/or flight cycles and/or landings and/or calendar time, and/or any other approved service life consumption units as appropriate; and
  - d) the current continuing airworthiness records as specified in paragraph 1.3.B.4) applicable to the component.
- 6) All entries made in the aircraft continuing airworthiness record system shall be clear and accurate. When it is necessary to correct an entry, the correction must be made in a manner that clearly shows the original entry.
- 7) GAM CAMO shall ensure that a system has been established to keep the following records for the periods specified:
- a) all detailed maintenance records in respect of the aircraft and any life-limited component fitted thereto, shall be kept until such time as the information contained therein is superseded by new information equivalent in scope and detail but not less than 36 months after the aircraft or component has been released to service; and



Issue No.	1
Revision No.	0

- b) the total time in service (hours, calendar time, cycles, landings or any other approved service life consumption units) of the aircraft and all service life-limited components, shall be kept at least 12 months after the aircraft or component has been permanently withdrawn from service; and
- c) the time in service (hours, calendar time, cycles, landings or any other approved service life consumption units) as appropriate, since last scheduled maintenance of the component subjected to a service life limit, shall be kept at least until the component scheduled maintenance has been superseded by another scheduled maintenance of equivalent work scope and detail; and
- d) the current status of compliance with all maintenance programme tasks such that compliance with the aircraft maintenance programme can be established, shall be kept at least until the aircraft or component scheduled maintenance has repeated; and
- e) the current status of airworthiness directives applicable to the aircraft and components, shall be kept at least 12 months after the aircraft or component has been permanently withdrawn from service; and
- f) details of current modifications and repairs to the aircraft, engine(s), propeller(s) and any other component vital to flight safety, shall be kept at least 12 months after they have been permanently withdrawn from service.

### **1.3.C. Preservation of Continuing Airworthiness Records**

- 1) Continuing airworthiness records are kept in paper form and kept scanned on a computer database. All records should remain readable and accessible for the duration of the storage period.
- 2) Paper systems should use robust material, which can withstand normal handling and filing.

### **1.3.D. Transfer of Continuing Airworthiness Records**

- 1) GAM CAMO shall ensure when an aircraft is permanently transferred from to another SAO, that the continuing airworthiness records as specified in paragraph 1.3.B. of this CAME and, if applicable, aircraft technical log as specified in paragraph 1.1.A, are also transferred.

- 2) GAM CAMO shall ensure that when the continuing airworthiness management of an aircraft is transferred to another CAMO, all retained records shall be transferred to the said CAMO.
- 3) The time periods prescribed for the retention of records shall continue to apply to the new owner of the aircraft or CAMO.
- 4) Where GAM CAMO ceases to hold the certificate of approval under TAO-M M.A Subpart G, all retained records shall be transferred to the owner of the aircraft.
- 5) The handover of these documents shall be documented and signed by both parties.

### **1.3.E. Computer Records System Backup**

- 1) Computer systems should have at least one backup system, which should be updated at least within 24 hours of any maintenance. Each terminal is required to contain program safeguards against the ability of unauthorised personnel to alter the database.

### **1.3.F. Backup Data Storage Location**

- 1) Continuing airworthiness records should be stored in a safe way with regard to damage, alteration, and theft. Computer backup discs, tapes etc., should be stored in a different location from that containing the current working discs, tapes, etc., in a safe environment.
- 2) Reconstruction of lost or destroyed records can be done by reference to other records which reflect the time in service, research of records maintained by repair facilities and reference to records maintained by individual mechanics, etc. When these things have been done and the record is still incomplete, GAM CAMO may make a statement in the new record describing the loss and establishing the time in service based on the research and the best estimate of time in service. The reconstructed records should be submitted to the DGTA for acceptance. The DGTA may require the performance of additional maintenance if not satisfied with the reconstructed records.



Issue No.	1
Revision No.	0

### **1.3.G. Access to Continuing Airworthiness Records**

- 1) The record-keeping system must ensure that all records are accessible within a reasonable time whenever they are needed. These records should be organised in a manner that ensures their traceability and retrievability throughout the required retention period of all activities developed.
- 2) CAM shall control the records as detailed in Chapter 1.3.B of this CAME and present the records to the DGTA upon request.



## **1.4. Accomplishment and Control of Airworthiness Directive**

### **1.4.0. General**

- 1) Any applicable airworthiness directive (AD) shall be carried out within the requirements of that airworthiness directive, unless otherwise specified by the DGTA.

### **1.4.A. Airworthiness Directive Information**

- 1) CAM shall be responsible to check AD periodically and to include them if appropriate into the maintenance planning according to AMP. Therefore he/she takes the AD published by the competent authority of the state of the type certificate holder of the aircraft/engine/components into account and those of the DGTA and other authorities using the following internet addresses:
  - a) EASA:  
<http://ad.easa.europa.eu>
  - b) FAA:  
<https://drs.faa.gov/>
  - c) TCCA:  
[https://wwwapps.tc.gc.ca/Saf-Sec-Sur/2/cawis-swimn/AD\\_h.aspx](https://wwwapps.tc.gc.ca/Saf-Sec-Sur/2/cawis-swimn/AD_h.aspx)
  - d) DGTA:  
<https://www.dgta.gov.my/>
  - e) Additionally:  
AD's of aircraft/engine/components issued state of manufacture.

### **1.4.B. Airworthiness Directive Decision**

- 1) All ADs shall be evaluated for general applicability to aircraft or aircraft components.
- 2) GAM CAMO shall evaluate the applicability of the AD and monitored the process flow until accomplishment by means of Technical Instruction Compliance (TIC).
- 3) If the AD is applicable, it is included in the maintenance planning and a work order is created in time to implement the AD onto the aircraft. The work order

together with the AD shall be forwarded to the contracted DGTA AMO for implementation.

- 4) If an emergency airworthiness directive is applicable, GAM CAMO shall immediately inform the owner / operator.
- 5) If the owner / operator cannot be reached in due time, GAM CAMO has the right to take necessary decisions. In order not to lose unnecessary time, an Emergency AD can be ordered by Phone or E-mail.
- 6) In case where the operator failed to incorporate an AD which is clearly affecting the aircraft or its component, this shall immediately be communicated with the operator. If the operator insists for not to incorporate the AD, GAM CAMO has the right to immediately terminate its services and contract.

#### **1.4.C. Airworthiness Directive Control**

- 1) AD must be performed in the period specified in the AD. Any deviation must be submitted to the respective State of Design authority for approval. Deviation request shall state the reason for request and shall include supporting data.
- 2) The CAM is responsible for control of performing and for request of deviation. He/She will establish the applicable work orders.
- 3) The CAM is responsible for incorporation and documentation of performed AD's. The CAM is also responsible to ensure that all applicable AD's will be performed in time as specified in the AD.
- 4) The method of compliance and when such compliance was achieved will be recorded in the aircraft continuing airworthiness records (Log Books) by GAM CAMO. For ADs with repetitive inspection content then each and every inspection will be recorded on completion in the aircraft airworthiness records.
- 5) Certificate of Release to Service (CRS) shall be issued every time compliance with an AD is established.
- 6) The CAM must ensure that a current status list of all AD's performed for each managed aircraft is administrated.
- 7) The listing consists of summary of records for all AD's that had been sentenced and compliance as applicable to the aircraft configuration. The status list shall contain the following information as applicable, but not limited to:



Issue No.	1
Revision No.	0

- a) aircraft make/model/serial number;
- b) engine make/model/serial number;
- c) APU make/model;
- d) component make/model;
- e) AD number;
- f) subject;
- g) date and hours/cycles at compliance;
- h) method of compliance (SB number, not applicable by S/N, etc.);
- i) one time action;
- j) recurring action (yes/no);
- k) next compliance due date (date/hours/cycles), if recurrent action is requested;
- l) accomplishment information.



## **1.5. Analysis of the Effectiveness of the AMP**

### **1.5.A. Procedures to Analyse the Effectiveness of the AMP**

- 1) GAM CAMO shall have a system to analyse the effectiveness of the maintenance programme, with regard to spares, established defects, malfunctions and damage, and to amend the maintenance programme accordingly.
- 2) The following tools are used in order to analyse the effectiveness of the AMP, such as:
  - a) pilot reports (including air turn-backs, etc.);
  - b) spare consumption;
  - c) repetitive technical occurrences and defects;
  - d) technical delays analysis (through statistics if relevant); and
  - e) technical incidents/accidents analysis (through statistics if relevant).

### **1.5.B. AMP Management Process**

#### **1.5.B.1. Amendment to the AMP**

- 1) Where appropriate and necessary, amendments to the AMP will be promulgated by the CAM for submission to DGTA as an amendment. Refer CAME Chapter 1.2.C.3.

#### **1.5.B.2. Amendment to the Maintenance or Operational Procedures**

- 1) The amended AMP shall be distributed to AMO and SAO for their reference and to amend their maintenance or operational procedures respectively as applicable for any limitation or instruction imposed by the AMP.

#### **1.5.B.3. Liaison Meetings**

- 1) The CAM will analyse and monitor the effectiveness of the AMP through regular Liaison Meetings with the owner/operator, the contracted AMO and the QM.
- 2) These meetings will address the following areas:





Issue No.	1
Revision No.	0

- a) the Aircraft maintenance programme content.
- b) the effect on the Aircraft maintenance programme of any ADs, modifications, or repairs.
- c) changes to the operation (e.g., utilisation), which may affect the Aircraft maintenance programme.
- d) maintenance findings.
- e) other defect reports i.e., air turn-backs, spares reliability, technical delays, technical incidents, repetitive defects, and pilot reports.
- f) quality monitoring product samples (aircraft surveys), when performed.
- g) changes to the manufacturer's maintenance guidance material, Service Bulletins Service Letters etc. and how these affect the Aircraft maintenance programme.
- h) other Quality System findings as they affect upon the contracted approved maintenance organisations.

#### **1.5.B.4. Frequency of Meetings**

- 1) Liaison meetings will be held at intervals not exceeding one year in conjunction with AMP annual review as stated in CAME paragraph 1.2.C.3.1) for every aircraft managed and the results of any meeting recorded with any actions required allocated to the responsible person.

## **1.6. Non-Mandatory Modification Embodiment Policy**

### **1.6.0. General**

- 1) GAM CAMO shall establish and work according to this policy, which assesses non-mandatory information (modification or inspections) related to the airworthiness of the aircraft against the Operating Organisation's need and operational experience.
- 2) Non-mandatory information refers to service bulletins, service letters and other information that is produced for the aircraft and its components by an approved design organisation, the manufacturer, State of Design or DGTA.
- 3) The decision on embodiment will be made by the operator or owner.

### **1.6.A. Policy**

- 1) Upon receipt of non-mandatory information through Technical Publication, GAM CAMO shall analyse the applicability of the modification against the aircraft configuration through TIC prior proposal to the aircraft owner / operator.

### **1.6.B. Procedures to Assess/Analyse and Decisions Taken**

#### **1.6.B.1. The Decision on their Application**

- 1) The decision on embodiment will be made by the operator or owner.

#### **1.6.B.2. Use of the Organisation's Risk Management Process**

- 1) If the owner/operator decides to implement any modification above, GAM CAMO shall ensure a risk assessment is conducted by the Safety Department through the Management of Change procedure.

#### **1.6.B.3. Records Keeping of the Assessment/Analyse Risk Management and Decisions are Taken**

- 1) The decisions taken and the risk management shall form part of the records.



### **1.6.C. Modification – General**

- 1) Modification is a change of design to the authorised configuration of the approved type design of a product, part or appliance.
- 2) Modification design data originating from an aeronautical product manufacturer are considered approved by DGTA subject to following conditions:
  - a) the modification design approval holder is the Type Certificate, STC, TSO authorisation or product approval holder of the product; and
  - b) the modification design is explicitly identified as approved by the State of Design or design organisation approved by the State of Design (e.g. EASA Part-21 Subpart J DOA, FAA DAH or TCCA DAO); and
  - c) the modification design is transmitted via service bulletins (SB) or equivalent documents.

### **1.6.D. Inspections**

- 1) Any inspection introduced during non-mandatory modification shall be incorporated in the AMP.

### **1.6.E. Service Bulletin & Service Letter**

- 1) Service Bulletins and all other necessary technical publications are directly received on the basis of subscriptions from the official dealers.
- 2) All manufacturers' Service Bulletins applicable to the aircraft managed by GAM CAMO shall be reviewed in the first instance by the CAM for applicability. Where compliance with the modification or inspections in the Service Bulletins may be seen as beneficial in consideration of the technical, operational and economical effects to GAM CAMO, a proposal shall be made to the owner/operator.



### **1.6.F. The Other Modifications**

- 1) For all modifications other than those introduced by manufacturer's SB's i.e. those proposed by GAM CAMO or the contracted DGTA AMO for operational advantages or other reasons then these will be subject to the current DGTA modification procedures.
- 2) In the first instance, the DGTA will be consulted for advice with an outline for the proposed change with a view to ascertaining whether or not a change is deemed to be classified as 'Major' or 'Minor'. Refer CAME Chapter 1.9 for further details.

### **1.6.G. Minor Modifications**

- 1) A 'minor modification' has no appreciable effect on the weight, balance, structural strength, reliability, operational characteristics, operational suitability data, or other characteristics affecting the airworthiness of the product or its environmental characteristics. All other modifications are 'major modifications'.
- 2) GAM is also an Authorised Engineering Organisation under. For minor modification outside of categories and scope of GAM AEO, the CAM or the owner/operator shall establish data package for the minor modification. All minor changes have to be agreed by the CAM before submission to DGTA for approval. In case of using an appropriately AEO, further approval by DGTA is not required.

### **1.6.H. Standard Changes and Standard Repairs**

- 1) Standard changes and standard repairs shall be carried out in accordance with approved maintenance data.

### **1.6.I. Instruction for Continuing Airworthiness – AMP**

- 1) GAM CAMO shall incorporate the instructions for continuing airworthiness pertaining to a modification / repair into the AMP.
- 2) All changes to limited life components limits, if applicable, shall be incorporated in the maintenance programme following the modification / repair design approval.



## 1.6.J. Recording of Modification

- 1) Incorporation of all modifications, whether introduced through Service Bulletins or DGTA approved Minor/Major modifications, shall be recorded in the aircraft continuing airworthiness records.
- 2) The status of current modification and repairs means a list of embodied modifications and repairs together with the substantiating data supporting compliance with the airworthiness requirements. This can be in the form of a Supplemental Type-Certificate (STC), Service Bulletin, Structural Repair Manual (SRM) or similar approved document.
- 3) The substantiating data may include:
  - a) compliance programme; and
  - b) master drawing or drawing list, production drawings, and installation instructions; and
  - c) engineering reports (static strength, fatigue, damage tolerance, fault analysis, etc.); and
  - d) ground and flight test programme and results; and
  - e) weight and balance change data; and
  - f) maintenance and repair manual supplements; and
  - g) AMP changes and Instructions for Continuing Airworthiness; and
  - h) aircraft flight manual supplement; and
  - i) symmetry check report (if applicable).
- 4) When applicable, GAM CAMO shall incorporate into the existing operating data supplements to the approved aircraft flight manual, maintenance instructions, instructions for continuing airworthiness and repair instructions pertaining to a modification. GAM CAMO shall record the incorporation of the required supplements in the appropriate revision logs.

	<b>Continuing Airworthiness Management Exposition (CAME)</b>	
	Issue No.	<b>1</b>
	Revision No.	<b>0</b>

**1.6.K. Liaison with Operator / Owner**

- 1) The CAM is responsible to notify any implementation or incorporation of all non-mandatory changes, to the operator / owner through Liaison Meetings in addition to those identified in Chapter 1.5.B.3 of this CAME.



## **1.7 Major Repair and Modification Standards**

### **1.7.A. Modification – General**

- 1) Modification means a change to the type design of an aeronautical product which is not a repair. Repair means the restoration of an aeronautical product to an airworthy condition as defined by the appropriate airworthiness requirement.

### **1.7.B. Type of Approval Required**

- 1) GAM CAMO shall ensure that modifications and repairs incorporated in the aircraft are approved by DGTA accordingly.
- 2) Damage shall be assessed and modifications and repairs carried out using as appropriate:
  - a) data approved by the DGTA; or
  - b) data approved by a DGTA AEO; or
  - c) data produced by an organisation accepted by the DGTA.
- 3) Any deviations to the installation / repair instructions provided by the design approval holder required during the embodiment of modification / repair shall be deemed as a revision to a modification / repair design and shall be approved accordingly.

### **1.7.C. Assessment**

- 1) GAM CAMO has the ultimate responsibility to verify compatibility with other modifications and repairs before installing any new modifications or repairs on the aircraft.
- 2) The installer of the modifications / repair specified shall survey the aircraft records and the aircraft itself to determine what other modification or repair exist on the aircraft. Any questions of incompatibility with other modifications or repairs arising from the survey shall be referred for resolution to GAM CAMO.
- 3) GAM CAMO shall provide the installer with information on all existing modification or repair to the aircraft so that compatibility may be verified. Any questions of modification / repair incompatibility which may arise during



Issue No.	1
Revision No.	0

installation or in service shall be thoroughly investigated by consultation with the modification / repair design approval authority or modification / repair design approval holder.

- 4) In every case of incompatibility between modifications or repairs, the problem shall be corrected and it must be established to the satisfaction of the DGTA of that the modified / repaired aircraft continues to comply with the applicable standards of airworthiness.
- 5) GAM CAMO shall promptly report any modification / repair incompatibilities detected during installation or in service to the modification / repair design approval holder, to the installer and to DGTA.

#### **1.7.D. Instruction for Continuing Airworthiness – AMP**

- 1) GAM CAMO shall incorporate the instructions for continuing airworthiness pertaining to a modification / repair into the AMP.
- 2) All changes to limited life components limits, if applicable, shall be incorporated in the maintenance programme following the modification / repair design approval.

#### **1.7.E. Critical Design Configuration Control Limitation (CDCCL)**

- 1) Not applicable.

#### **1.7.F. Recording of Modification**

- 1) Incorporation of all modifications, whether introduced through Service Bulletins or DGTA approved Minor/Major modifications, shall be recorded in the aircraft continuing airworthiness records.
- 2) The status of current modification and repairs means a list of embodied modifications and repairs together with the substantiating data supporting compliance with the airworthiness requirements. This can be in the form of a Supplemental Type-Certificate (STC), Service Bulletin, Structural Repair Manual (SRM) or similar approved document.
- 3) The substantiating data may include:
  - a) compliance programme; and



- b) master drawing or drawing list, production drawings, and installation instructions; and
  - c) engineering reports (static strength, fatigue, damage tolerance, fault analysis, etc.); and
  - d) ground and flight test programme and results; and
  - e) weight and balance change data; and
  - f) maintenance and repair manual supplements; and
  - g) AMP changes and Instructions for Continuing Airworthiness; and
  - h) aircraft flight manual supplement; and
  - i) symmetry check report (if applicable).
- 4) When applicable, GAM CAMO shall incorporate into the existing operating data supplements to the approved aircraft flight manual, maintenance instructions, instructions for continuing airworthiness and repair instructions pertaining to a modification / repair. GAM CAMO shall record the incorporation of the required supplements in the appropriate revision logs.

### **1.7.G. Liaison with Operator / Owner**

- 1) The CAM is responsible to notify any implementation or incorporation of all mandatory changes, especially in relating to the Flight Manual and MEL supplements, to the Operator / owner through Liaison Meetings in addition to those identified in Chapter 1.5.B.3 of this CAME.



## 1.8. Defect Reports

### 1.8.A. Analysis

- 1) A system of assessment should be in operation to support the continuing airworthiness of an aircraft and to provide a continuous analysis of the effectiveness of the approved continuing airworthiness management organisation's defect control system in use.
- 2) The system should provide for:
  - a) significant incidents and defects: monitor incidents and defects that have occurred in flight and defects found during maintenance and overhaul, highlighting any that appear significant in their own right.
  - b) repetitive incidents and defects: monitor on a continuous basis defects occurring in flight and defects found during maintenance and overhaul, highlighting any that are repetitive.
  - c) deferred and carried forward defects: Monitor on a continuous basis deferred and carried forward defects. Deferred defects are defined as those defects reported in operational service which are deferred for later rectification. Carried forward defects are defined as those defects arising during maintenance which are carried forward for rectification at a later maintenance input.
  - d) unscheduled removals and system performance: analyse unscheduled component removals and the performance of aircraft systems for use as part of the maintenance programme efficiency.
- 3) An assessment of both the cause and any potentially hazardous effect of any defect or combination of defects that could affect flight safety should be made in order to initiate any necessary further investigation and analysis necessary to identify the root cause of the defect.
- 4) A DGTA AMO repairing an aircraft or component should assess the damage against published approved repair data and the action to be taken if the damage is beyond the limits or outside the scope of such data. This action could involve any one or more of the following options:
  - a) the repair by replacement of the damaged parts;

- b) requesting technical support from the STC holder or a design organisation approved or accepted by the DGTA;
- c) DGTA approval of the particular repair data.

### **1.8.B. Liaison with Manufacturers and DGTA**

- 1) Defects during flight operation affecting flight safety shall be reported by the operator to DGTA and GAM CAMO.
- 2) Defects known to GAM CAMO during aircraft maintenance shall be reported to the operator, DGTA and TC holder.

### **1.8.C. Deferred Defect Policy**

- 1) In general, all identified defects shall be corrected before flight, deferred maintenance should as far as possible be avoided during scheduled maintenance and should be the last solution. However, under certain circumstances defects may be deferred if applicable conditions are met. Established Deferred defect policy must be referred.
- 2) GAM will seek to ensure that the minimum number of open Deferred Defects exist. All open Deferred Defects will be monitored by CAM in consultation with the owner or operator and the contracted maintenance organisation to ensure earliest rectification and subsequent closure.
- 3) All defects that are subject to deferral action will be as per the Minimum Equipment List and its guidelines for use. Defects such as cracks and structural defects that are not addressed in the MEL or CDL may only be deferred after agreement with the Type Certificate holder and that the defect is not of a safety concern.
- 4) When a Deferred Defect is raised, the CAM will consult with the contracted DGTA AMO with a view to arrange the earliest possible rectification action to be taken. This will involve the pre-allocation of down time, spares, personnel, tooling etc. as appropriate. A Certificate of Release to Service (CRS) will be issued upon clearance of any Deferred Defects.
- 5) It is of vital importance to contact the manufacturer as soon as any uncertainty exists.



#### **1.8.D. Non Deferrable Defects Away From Base**

- 1) In the following unforeseen cases, where an aircraft is grounded at a location other than the main base where no appropriate certifying staff are available, the organisation contracted to provide maintenance support may issue a one-off certification authorisation:
  - a) to one of its employees holding equivalent type authorisations on aircraft of similar technology, construction and systems; or
  - b) to any person with not less than five years maintenance experience and holding a valid ICAO aircraft maintenance licence rated for the aircraft type requiring certification provided there is no organisation appropriately approved under this Directive at that location and the contracted organisation obtains and holds on file evidence of the experience and the licence of that person.
- 2) All such cases as specified in this paragraph must be reported to DGTA within seven days after issuing such certification authorisation. The organisation issuing the one-off authorisation shall ensure that any such maintenance that could affect flight safety is re-checked by an appropriately approved organisation. The organisation shall have an approved procedure in place for managing the maintenance activity undertaken at the location under the authority of the one-off authorisation.

#### **1.8.E. Repetitive Defects**

- 1) Repetitive Defect is a defect in an aircraft or its component which recurs, in spite of rectifications attempted on the same aircraft or its component and system more than 3 times in a month.
- 2) The aircraft continuing airworthiness records are monitored by CAM to identify repetitive defects as and when they become apparent. Remedial action will be arranged with the contracted maintenance organisation in consultation with the owner/operator.

#### **1.8.F. Mandatory Occurrence Reporting**

- 1) GAM CAMO shall report to DGTA and all further addressees as required by national regulations, any identified condition of an aircraft or component which endangers flight safety.

- 2) Reports shall be made in a form and manner established by the DGTA and contain all pertinent information about the conditions known to the person.
- 3) Each report should contain at least the following information:
  - a) reporter or organisation's name and approval reference if applicable;
  - b) information necessary to identify the subject aircraft and/or component;
  - c) date and time relative to any life or overhaul limitation in terms of flying hours/cycles/landings etc., as appropriate;
  - d) details of the occurrence;
  - e) any other relevant information found during the evaluation or rectification of the condition;
  - f) fleet implications or ability to continue to conform with the type design.
- 4) Where the organisation maintaining the aircraft is contracted by an owner to carry out maintenance, the organisation maintaining the aircraft shall also report to the owner and GAM CAMO of any such condition affecting the owner's aircraft or component.
- 5) GAM CAMO shall ensure that the TC holder receives adequate reports of occurrence for the aircraft type, to enable it to issue appropriate service instructions and recommendations to all owners and/or operators.
- 6) Liaison with the TC holder is recommended to establish whether published or proposed service information will resolve the problem or to obtain a solution to a particular problem.
- 7) Finding reports shall be made as soon as practicable, but in any case within 72 hours of the person identifying the condition to which the report relates.

### **1.8.G. Liaison Meetings**

- 1) All occurrences, which have maintenance implications, shall be analysed by the CAM in consultation with the approved AMO. Any maintenance occurrence reports raised by the contracted AMO on GAM CAMO managed aircraft shall also be advised to the CAM.



Issue No.	1
Revision No.	0

- 2) Both organisations shall hold copies of any reports that have been raised that affect maintenance. Liaison meetings shall be held between the CAM, the contracted AMO, the QM and any other involved parties to discuss occurrence reports issues.
- 3) The frequency of these meetings shall be held as necessary if required by maintenance findings and/or operational circumstances.

## 1.9. Engineering Activity

### 1.9.A. Procedure for Approval of Modifications and Repairs

- 1) GAM is also an Authorised Engineering Organisation (AEO) with DGTA approval no. AEO 42/2022.
- 2) Modifications and repairs that are not within the scope of GAM AEO shall be submitted to DGTA for the approval of the particular repair data.

### 1.9.B. The Person Responsible for Accepting the Design Before Submission to the DGTA

- 1) DAR shall be responsible for accepting the design before submission to the DGTA.

### 1.9.C. Developing and submitting a modification/repair design for approval to DGTA

- 1) CAM shall submit request to GAM AEO for developing the modification data package on the design changes.
- 2) GAM AEO shall be responsible to submit design for approval to the DGTA.

### 1.9.D. Application process

- 1) GAM AEO shall be responsible to submit design for approval to the DGTA.
- 2) For major modifications / repairs, refer as per figure below:

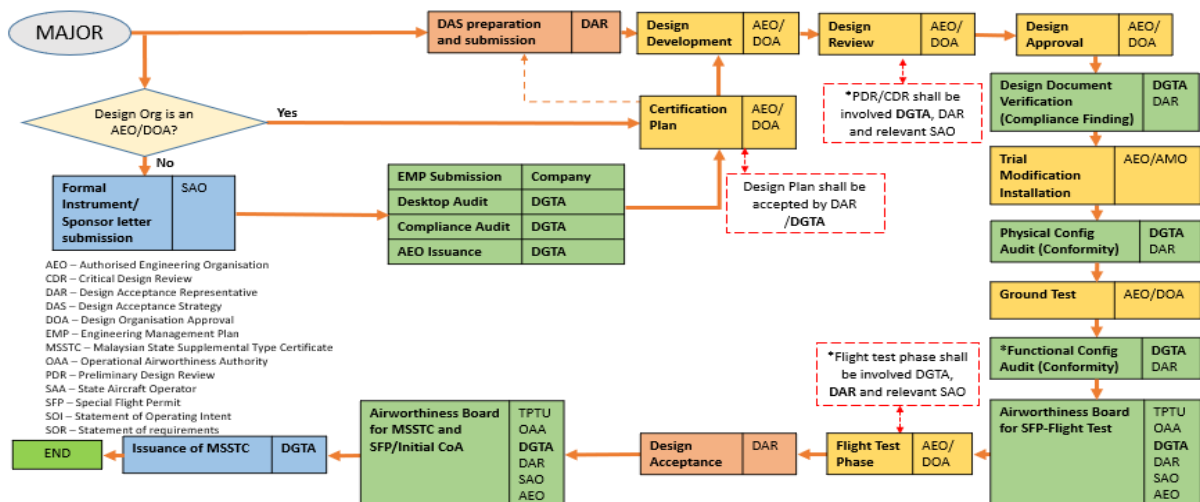

3) For minor modifications / repairs, refer as per figure below:

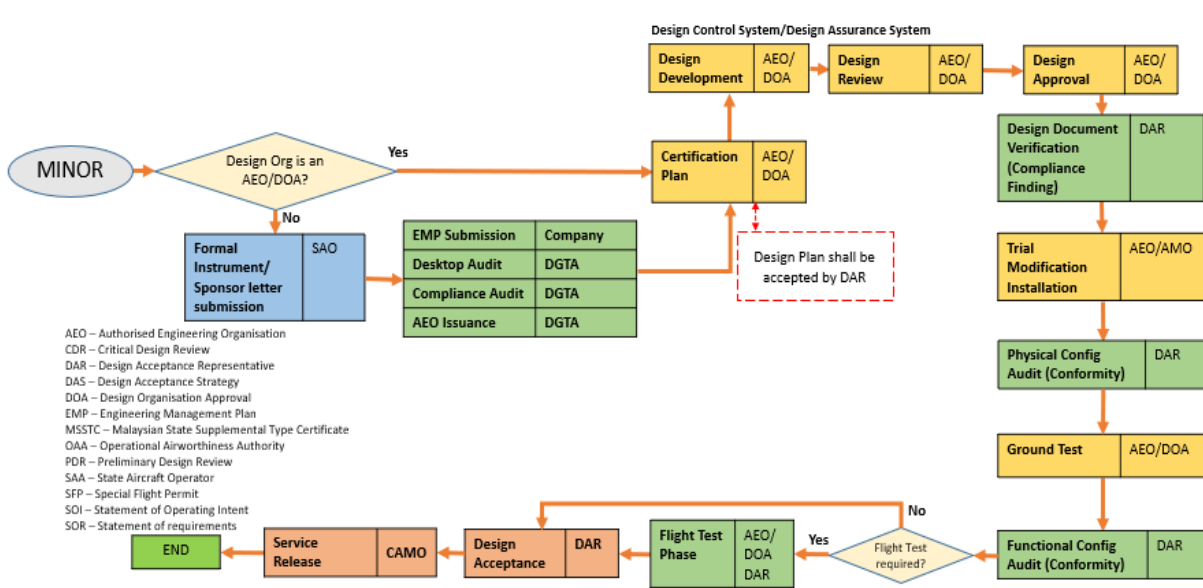

### 1.9.E. Supporting documents

- GAM AEO shall prepare all related documents in developing the modification data package on the design changes.

### 1.9.F. Form used

- Modification data package shall use forms as detailed in AEO. GAM CAMO shall raise workpack for the embodiment of modifications / repair.

### 1.9.G. GAM (M)DOA Capability Under TAO-21

- GAM is also an Authorised Engineering Organisation (AEO) with DGTA approval no. AEO 42/2022.





## **1.10. Reliability Programmes**

### **1.10.0. General**

- 1) The purpose of a reliability programme is to ensure that the AMP tasks are effective and their periodicity is adequate.
- 2) The reliability programme may result in the extension or reduction of a maintenance task interval, as well as the deletion or addition of a maintenance task.
- 3) A reliability programme provides an appropriate means of monitoring the effectiveness of the AMP.

### **1.10.A. Extent and Scope of the Reliability Programme**

- 1) A reliability programme should be developed for an aircraft, including its engines, propellers and components in the following cases:
  - a) the aircraft maintenance programme is based upon MSG-3 logic;
  - b) the aircraft maintenance programme includes condition monitored components;
  - c) the aircraft maintenance programme does not contain overhaul time periods for all significant system components;
  - d) when specified by the Manufacturer's maintenance planning document or MRB.
- 2) A reliability programme need not be developed in the following cases:
  - a) the maintenance programme is based upon the MSG-1 or 2 logic but only contains hard time or on condition items;
  - b) the aircraft maintenance programme provides overhaul time periods for all significant system components.
- 3) Notwithstanding paragraphs 1.10.A.1) and 1.10.A.2) above, GAM CAMO may however, develop its own reliability monitoring programme when it may be deemed beneficial from a maintenance planning point of view.
- 4) The scope of the reliability program is to:



- a) monitor the effectiveness of the maintenance program tasks;
- b) evaluate whether the tasks periodicity is adequate with regards to spares utilisation, established defects, malfunctions and damage recorded;
- c) identify components and systems that deviates from its expected pattern of behaviour;
- d) recognize the need for corrective actions;
- e) establish the corrective actions;
- f) determine the effectiveness of the implemented corrective actions.

#### **1.10.B. Organisational Structure, Duties and Responsibilities**

- 1) The Maintenance Review Board (MRB) holds monthly meetings and constitutes of the following members:
  - a) CAM Manager or his/her delegate
  - b) QM or his/her delegate
  - c) EM or his/her delegate
  - d) Technical Services Engineer
  - e) Logistic supervisor

#### **1.10.C. Establishment of Reliability Data**

- 1) The type of information to be collected should be related to the objectives of the Programme and should be such that it enables both an overall broad based assessment of the information to be made and also allow for assessments to be made as to whether any reaction, both to trends and to individual events, is necessary. The following are examples of the normal prime sources:
  - a) pilot reports;
  - b) technical logs;
  - c) aircraft maintenance access terminal / on-board maintenance system readouts;



Issue No.	1
Revision No.	0

- d) maintenance worksheets;
- e) workshop reports;
- f) reports on functional checks;
- g) reports on special inspections;
- h) stores issues / reports;
- i) air safety reports;
- j) reports on Technical Delays and Incidents;
- k) other sources: EDTO, RVSM, CAT II/III;
- l) continuing airworthiness and safety information promulgated under Part-21 will also be taken into consideration.

#### **1.10.D. Analysis of Reliability Data**

- 1) The collected information shall be analysed for the identification of trends, specific highlights and related events. The analysis and interpretation of information shall enable a critical assessment of the effectiveness of the programme and shall take the following points into consideration:
  - a) comparisons of operational reliability with established or allocated standards (in the initial period these could be obtained from in-service experience of similar equipment of aircraft types);
  - b) analysis and interpretation of trends;
  - c) evaluation of repetitive defects;
  - d) confidence testing of expected and achieved results;
  - e) studies of life-bands and survival characteristics;
  - f) reliability predictions;
  - g) identification of hazards and risks and how they are fed into the management system.



Issue No.	1
Revision No.	0

- 2) The range and depth of engineering analysis and interpretation should be related to the particular programme and to the facilities available. The following, at least, should be taken into account:
- a) flight defects and reductions in operational reliability;
  - b) defects occurring on-line and at main base;
  - c) deterioration observed during routine maintenance;
  - d) workshop and overhaul facility findings;
  - e) modification evaluations;
  - f) sampling programmes;
  - g) the adequacy of maintenance equipment and publications;
  - h) the effectiveness of maintenance procedures;
  - i) staff training;
  - j) service bulletins, technical instructions, etc.

#### **1.10.E. Corrective Action System**

- 1) Corrective actions shall correct any reduction in reliability revealed by the programme and could take the form of:
- a) changes to maintenance, operational procedures or techniques;
  - b) maintenance changes involving inspection frequency and content, function checks, overhaul requirements and time limits, which will require amendment of the scheduled maintenance periods or tasks in the approved maintenance programme. This may include escalation or de-escalation of tasks, addition, modification or deletion of tasks;
  - c) amendments to approved manuals (e.g. maintenance manual, crew manual);
  - d) initiation of modifications;
  - e) special inspections of fleet campaigns;

- f) spares provisioning;
  - g) staff training;
  - h) manpower and equipment planning.
- 2) Some of the above corrective actions may need the DGTA's approval before implementation.

### **1.10.F. Scheduled Reviews**

- 1) The Maintenance Review Board (MRB) holds monthly meetings The followings shall be in the agenda but not limited to:
- a) reliability reports are evaluated, and a review of each delay and cancellation is carried out;
  - b) identify any adverse trends and associated technical problems for further investigation;
  - c) determine required actions to reduce recurring defect or significant event;
  - d) formulate actions that can rectify dispatch reliability being below set targets;
  - e) review actions taken on PIREP Rate Alert's and high unscheduled removal rate components;
  - f) proposals for corrective and preventive actions and for Aircraft Maintenance Programme changes are evaluated from incident,decisions made by majority vote.
- 2) CAM shall initially review the reliability report for data accuracy prior to the meeting above.
- 3) The Programme shall be reviewed and, as necessary, revising the reliability 'standards' or 'alert levels' annually. Although not exclusive, the following list gives guidance on the criteria to be taken into account during the review.
- a) utilisation (high/low/seasonal);
  - b) fleet commonality;
  - c) alert Level adjustment criteria;



Issue No.	1
Revision No.	0

- d) adequacy of data;
- e) reliability procedure audit;
- f) staff training;
- g) operational and maintenance procedures.



## **1.11. Pre-flight Inspections**

### **1.11.0 General**

- 1) GAM CAMO shall be responsible for the satisfactory accomplishment of the pre-flight inspection through the ATL. The pre-flight inspection shall be carried out by the pilot or another qualified person but need not be carried out by an approved maintenance organisation.

### **1.11.A Preparation of Aircraft for Flight**

- 1) With regard to the pre-flight inspection shall be done by aircrew iaw flight manual, it is intended to mean all of the actions necessary to ensure that the aircraft is fit to make the intended flight. These should typically include but are not necessarily limited to:
  - a) a walk-around type inspection of the aircraft, its emergency equipment and any stores/weapons carried for condition including, in particular, any obvious signs of wear, damage or leakage. In addition, the presence of all required equipment, including emergency equipment should be established and the security of attachment of any stores/weapons carried should be checked;
  - b) an inspection of the aircraft continuing airworthiness record system or the aircraft technical log as applicable to ensure that the intended flight is not adversely affected by any outstanding deferred defects and that no required maintenance action shown in the maintenance statement is overdue or will become due during the flight;
  - c) a control that consumable fluids, gases etc. uplifted prior to flight are of the correct specification, free from contamination, and correctly recorded;
  - d) a control that all doors are securely fastened;
  - e) a control that controls surface and landing gear locks, pitot/static covers, restraint devices and engine/aperture blanks have been removed; and
  - f) a control that all the aircraft's external surfaces and engines are free from ice, snow, sand, dust etc. and an assessment to confirm that, as the result of meteorological conditions and de-icing/anti-icing fluids having been previously applied on it, there are no fluid residues that could endanger flight safety. Alternatively, to this pre-flight assessment, when the type of aircraft

and nature of operations allow for it, the build-up of residues may be controlled through scheduled maintenance inspections/cleanings identified in the AMP;

- g) removal of safety/arming pins, if applicable.
- 2) Tasks such as oil and hydraulic fluid uplift and tyre inflation may be considered as part of the pre-flight inspection. The related pre-flight inspection instructions should address the procedures to determine where the necessary fluid uplift or tyre inflation results from an abnormal consumption/excessive leakage, thereby possibly requiring additional maintenance action by the AMO or certifying staff as appropriate.

### **1.11.B Concurrent with AMP**

- 1) The pre-flight inspection contain in the AMP shall also be performed prior flight concurrent wit the pre-flight inspections above in paragraph 1.11.A.
- 2) The inspection shall be performed by qualified maintenance personnel or by an authorised pilot when aircraft is out of base.
- 3) Authorised pilot is addressed to pilot which has been task trained and granted approval by Quality Manager of GAM CAMO as per CAME paragraph 1.11.D below.

### **1.11.C Control Publishing Guidance To Maintenance And Flight Personnel To Perform Pre-Flight Inspection And Defining Responsibilities For These Actions**

- 1) The pilot pre-flight inspections are as listed in the flight manual. GAM CAMO shall ensure the flight manual copy on board of aircraft are kept controlled and updated.
- 2) The maintenance pre-flight inspection listed in the AMP shall be distributed to contracted AMO for accomplishment of the inspections.
- 3) The accomplishment of the pre-flight inspection are signed through the ATL.
- 4) Any defect appeared during the pre-flight inspections is reported to CAM using the ATL. The CAM manages the performance of any required maintenance resulting from the checks above at the contracted AMO.



- 5) In the case of aircraft operating away from a supported location, the contracted AMO may issue a limited certification authorisation to the commander and/ or the flight engineer on the basis of the flight crew licence held subject to being satisfied that sufficient practical training has been carried out to ensure that the commander or flight engineer can accomplish the specified task to the required standard.

#### **1.11.D Responsibility For Training Personnel Performing The Pre-Flight Inspection**

- 1) The personnel performing pre-flight inspection shall receive appropriate training for the relevant task by the contracted AMO.
- 2) GAM CAMO shall made request to AMO for the nominated Pilot to be task trained to perform the pre-flight inspection as required by the AMP.
- 3) Upon completion of training, CAM shall made application to QM for the pilot authorisation. QM shall issue authorisation to the nominated pilot valid for a period as specified in the authorisation certificate.

#### **1.11.E Content of Pre-Flight Inspection Training**

- 1) The pre-flight inspection training shall be based on the AMP and the applicable aircraft maintenance manual.

#### **1.11.F Records of Training**

- 1) The records of training shall be kept by QM.



## 1.12. Aircraft Weighing

- 1) GAM CAMO shall be responsible to:
  - a) develop and maintain a weight and balance programme;
  - b) prepare the aircraft weight and balance programme document; and
  - c) manage the weight and balance control of the aircraft.
- 2) The aircraft shall be weighed/ reweighed at the following occasions:
  - a) to determined weight and CG of each aircraft prior to issuance of the C of A;
  - b) whenever DGTA requires;
  - c) whenever required by aircraft TC holder;
  - d) whenever DGTA, GAM CAMO or the operator is of the opinion that adequate weight control has not been exercised over an aircraft during the modification or repair embodiment;
  - e) after a major modification where the new weight and balance cannot be calculated based on weight and balance information in the modification documentation;
  - f) after installation of equipment where the new weight and balance cannot be calculated based on reliable weight information for the installed equipment;
  - g) after repainting of the aircraft;
  - h) not exceed 4 years intervals consecutively.
- 3) By derogation to the para 1.12.2 a) above, an aircraft may not be required to be weighed by the operator prior to the issuance C of A in case of newly manufactured aircraft where the weight and CG has been determined by the manufacturer and recorded.
- 4) By derogation to the para 1.12.2 a) above, in the case of a used aircraft, the aircraft may not be required to be weighed by the operator prior to the issuance C of A aircraft if:

- a) the operator is able demonstrate that the aircraft has been last weighed in accordance with this procedures;
  - b) the aircraft is unmodified or only minimally modified (i.e. where it is explicitly specified in the modification data there is no appreciable effect on aircraft weight and balance); and
  - c) any changes to weight computed and recorded in the previous weight and balancereport.
- 5) Aircraft weighing shall be performed by AMO in accordance with DGTA requirement as applicable. Aircraft weighing activity shall be supervised by Weighing Engineer to ensure compliance to the requirements of DGTA.
  - 6) Aircraft weighing shall be carried out in accordance with instructions and recommendations of the aircraft type certificate holder, supplemental type certificate holder and weighing scale manufacturer as applicable. If such data is not available. GAM CAMO shall be responsible for developing appropriate weighing instructions for its particular aircraft as may be agreed by DGTA.
  - 7) GAM CAMO shall be responsible to coordinate the aircraft weighing activity with operator and contracted AMO and raise the worksheet accordingly.
  - 8) Weight and balance report shall be issued for every aircraft by the CAMO. The report shall be completed and certified by WE.
  - 9) GAM CAMO shall maintain a complete, current, and continuous record of changes of empty weight, arm and empty centre of gravity limits for each aircraft. Details of modifications, repairs or other changes affecting either the weight and/or CG of the aircraft shall be recorded and listed.
  - 10) The current weight and balance shall be carried on board of aircraft and another copy shall be attached to the work pack. The next due for the aircraft weighing shall be entered and monitored in CAMS.
  - 11) When the weight and balance report is reissued/revised, the last issue/revision shall be retained with the aircraft records for at least six (6) months.



## **1.13. Maintenance Check Flight Procedures**

### **1.13.1. General**

- 1) A maintenance check flight is considered necessary after special maintenance and/or repair work on aircraft. Only suitable qualified pilots accepted by the owner/operatr can carry out flight tests considering DGTA requirements.
- 2) A maintenance check flight is considered necessary after the following events have taken place:
  - a) any time after maintenance has been performed where the manufacturer of the aircraft or engine require a check flight;
  - b) any time maintenance has been performed which could change the flight characteristics of the aircraft;
  - c) any time after replacement of a primary flight control if required;
  - d) after major repair or modification on the aircraft which alters the flight characteristics;
  - e) after change of engine(s);
  - f) during an Airworthiness Inspection when required by the DAR.
- 3) For certain maintenance check flights, the data obtained or verified in flight will be necessary for assessment or consideration after the flight by the maintenance organisation prior to issuing the maintenance release. For this purpose, when the personnel of the maintenance organisation cannot perform these functions in flight, the maintenance organisation may rely on the crew performing the flight to complete these data or to make statements about in-flight verifications. In this case the maintenance organisation should appoint the crew personnel playing such a role and brief them on their functions before the flight.

### **1.13.2. Check Flight Procedure**

- 1) Check flight is not carried out at specific intervals. All check flights will be performed by the minimum flight crew, but inspectors and mechanics, who are directly involved in the preceding work may be on board. All check flight procedures are established in accordance with the applicable AFM or AMM.

Issue No.	<b>1</b>
Revision No.	<b>0</b>

This procedure should also be carried out following maintenance, modification or rectification actions affecting the aircraft performance, handling etc or where required by the manufacturer. All technical flight tests are carried out to the flight test schedule generated appropriate to specific need.

- 2) Prior to any check flight, a Certificate of Release to Service, stating the work accomplished has to be issued by the AMO in the ATL. After successful performance of the maintenance check flight the full release is issued.

## **PART 2 QUALITY SYSTEM**

### **2.1. Continuing Airworthiness Quality Policy, Quality Plan And Quality Audit Procedure**

- 1) This Part 2 of CAME defines the continuing airworthiness quality policy, planning and procedures to meet the requirements of DGTA TAO-M M.A. Subpart G.
- 2) The Quality System and associated Quality Assurance Programme enables monitoring of compliance with Part M, the CAME and any other standards specified by DGTA to ensure safe operations and airworthy aircraft.

#### **2.1.A. Continuing Airworthiness Quality Policy**

- 1) The primary objectives of the quality system are to enable GAM CAMO to ensure airworthy aircraft and to remain in compliance with the TAO-M requirements.
- 2) The AM has the overall responsibility that the managing of continuing airworthiness will be ensured on the aircraft listed in 5.4. The CAM and the QM have at all times direct access to the AM.
- 3) GAM CAMO personnel are encouraged to participate actively in the quality system by reporting all discrepancies and suggestions for improvements to the QM or AM.
- 4) The AM has also the overall responsibility for the quality system including the frequency, format and structure of the internal management evaluation activities as prescribed below.
- 5) An essential element of the quality system is the independent monitoring function to ensure GAM CAMO compliance with the applicable requirements, policies, and procedures. The quality system shall monitor activities carried out and shall at least include the following functions:
  - a) monitoring that all activities carried out under TAO-M M.A. Subpart G are being performed in accordance with the approved procedures;
  - b) monitoring that all contracted maintenance is carried out in accordance with the contract;



Issue No.	1
Revision No.	0

- c) monitoring the continued compliance with the requirements of TAO-M M.A. Subpart G; and
  - d) monitoring that all subcontracted continuing airworthiness management tasks is carried out in accordance with the contractual obligations.
- 6) The independent quality audit reports referenced in paragraph 2.1.C.3) above shall be sent to the relevant department for rectification action giving target rectification dates where non-compliances are identified. Compliance monitoring shall include a feedback system to the AM to ensure corrective action as necessary.
- 7) The independence of the audit is established by always ensuring that audits and inspections are carried out by personnel who are not responsible for the functions, procedures or products that are audited or inspected.

### **2.1.B. Quality Plan (Programme)**

- 1) The Quality Programme is developed by the QM in liaison with CAM. The QM implements an audit which during a twelve-month period addresses the whole continuing airworthiness management activity and all of the aspects of TAO-M which have a bearing on the continuing airworthiness arrangements of GAM CAMO including:
- a) the independence of quality system established;
  - b) subcontracted activities (if applicable);
  - c) product sampling;
  - d) each location approved.
- 2) The Quality Programme will also address those aspects of the individual aircraft's continuing airworthiness which would have been covered by the DAR.
- 3) Additional audits are to be carried out:
- a) additional aircraft rating for GAM CAMO scope of approval;and
  - b) before subcontracting of airworthiness management activities take place.
- 4) GAM CAMO shall establish an audit plan acceptable to DGTA to show when and how often the activities as required by TAO-M M.A. Subpart G will be



Issue No.	1
Revision No.	0

audited. The audit plan shall be established annually combining GAM CAMO and GAM AMO compliance monitoring by using form GAM/Q-007. The audit plan is properly implemented, maintained, and continually reviewed and improved.

- 5) Rectification dates should be discussed with such department before the quality department or nominated quality auditor confirms such dates in the report. The relevant department is required to rectify findings and inform the QM or the quality auditor of such rectification.

### **2.1.C. Quality Audit Procedure**

- 1) An audit consists of identifying, in an objective fashion, non-conforming practices against the applicable regulation (TAO-M) and the procedures set out in this CAME. This independent audit is an objective process of routine sample checks of all aspects of the CAMO including some product audits as the end result of the process.
- 2) Every audit is subjected to a deviation report. Before distribution, the preliminary conclusions are presented to the person audited. The auditor and the CAM determine in common the corrective actions to be taken, as well as the time allowed for implementation. The corrective action should be determined taking into account the root cause of the finding or concern, so that the corrective action may be designed in order the non-conformity may not reoccur.
- 3) A report should be raised each time an audit is carried out describing:
  - a) what was checked (area, product, etc.);
  - b) What paragraphs were audited;
  - c) What amendment in regulation was used;
  - d) What procedures were audited;
  - e) The resulting non-compliance findings against applicable requirements, procedures; and products;
  - f) The target date for proposal for a corrective action plan;
  - g) Target closure date for corrective action;





- h) Responsible manager for Corrective Action Plan and Correction Action.
- 4) Rectification dates should be discussed with such department before the quality department or nominated quality auditor confirms such dates in the report. The relevant department is required to rectify findings and inform the QM or the quality auditor of such rectification.
  - 5) The QM has to carry out aircraft and product quality audits at random intervals and whenever additionally required to new or unusual circumstances.
  - 6) Sample checks will be performed by the QM, he witnesses any relevant maintenance task and visually inspects the product and the associated documentation. During a sample check performed by the QM, repeat disassembly or testing should not be performed by maintenance staff, unless findings are identified by the QM which requiring such action.

#### **2.1.D. Quality Audit Remedial Action Procedure**

- 1) The QM monitors the remedial actions and their compliance.
- 2) Any findings are classified into the following categories:
  - a) Level 1 finding  

any significant non-compliance with requirements laid down in TAO-M M.A. Subpart G which lowers the safety standard and hazards seriously the flight safety. Notification to DGTA is required on the findings. The certificate of approval shall cease to be in force immediately until acceptable corrective action has been taken by GAM CAMO.
  - b) Level 2 finding  

any non-compliance with requirements laid down in TAO-M M.A. Subpart G which could lower the safety standard and possibly hazard the flight safety or is a non-compliance to the CAME procedures.
- 3) The above-mentioned levels of findings require rectifications by the responsible management personnel within the following time frame:
  - a) Level 1 finding immediately;
  - b) Level 2 finding within 14 days after receipt of notificaton of findings.

- 4) When objections or defects are determined during an audit, the QM and CAM are to decide upon corrective actions and/or procedure improvements. The decided corrective actions and/or procedure improvements are then to be conveyed to the AM.
- 5) The CAM shall make necessary corrections initially and further analyse/investigate the root causes and take necessary corrective and preventive actions as per the agreed timeline. In this regard, the preventive action should address the root cause of the respective finding and rechecked against other product lines to ensure there is no recurrence.
- 6) If either the corrective or preventive action taken is not considered to be satisfactory, the issue will be highlighted to the CAM for further necessary action so the CAM will re-analyse the non-conformances and address necessary root cause analysis, preventive measures and corrective actions.
- 7) If no corrective or insufficient action has been taken, the QM shall inform the AM accordingly.
- 8) For receipt of notification of findings of an audit of DGTA, according to TAO-M M.A. Subpart G, GAM CAMO shall:
  - a) accomplish immediate corrective action for level 1 findings to the satisfaction of the DGTA, else the certificate of approval shall cease to be in force immediately;
  - b) accomplish the corrective action to the satisfaction of the DGTA within 14 days after receipt of notification of level 2 findings, unless otherwise agreed by DGTA. If fails, GAM CAMO approval shall cease to be in force until acceptable corrective action has been taken by GAM CAMO;
  - c) define a preventive action and demonstrate the preventive action to the satisfaction of DGTA within 90 days unless otherwise agreed by DGTA.



Issue No.	1
Revision No.	0

## **2.2 Monitoring of Continuing Airworthiness Management Activities**

- 1) The Audit Plan includes an assessment of the Continuing Airworthiness Management activities against the procedures defined in the CAME and in particular the ability of the CAM's ability to discharge their responsibilities effectively with respect to TAO-M.
- 2) All procedures of continuing airworthiness shall be audited annually and recorded in the Audit Report form (GAM/Q-009) and Audit Check List form (GAM/Q-008D). Audit procedures and remedial action procedures are the same as Chapter 2.1.C. and 2.1.D. of this CAME.



Issue No.	1
Revision No.	0

## **2.3 Monitoring of the Effectiveness of the Maintenance Programme**

- 1) The Audit Plan as carried out by the Quality Manager includes a review of the effectiveness of the Aircraft Maintenance Programme. This review will critically analyse the findings and actions taken as a result of Chapter 1.5 of this CAME.



Issue No.	1
Revision No.	0

**2.4 Monitoring that All Maintenance is Carried Out by an Appropriate TAO-145 Approved Maintenance Organisation (AMO)**

- 1) The Annual Audit Plan includes verification that the contracted maintenance organisation's approval is relevant to the maintenance being performed on the aircraft managed by GAM CAMO.
- 2) Any feedback information from any contracted organisation on any actual or contemplated amendments to the maintenance contracts for aircraft, engines or components to ensure that the maintenance system remains valid and to anticipate any necessary change in the maintenance agreements should be reviewed and the contracts amended accordingly.



Issue No.	1
Revision No.	0

**2.5 Monitoring that all Contracted/Tasked Maintenance is Carried Out in Accordance with the Contract/Tasking, including Maintenance Organisation not Approved to TAO-145 Used by The Maintenance Contractor/Tasked Organisation**

- 1) The Audit Programme shall include a review of all maintenance provided to GAM CAMO by the contracted AMO, including sub-contractors. This review will assess all of the contracted maintenance is carried out in accordance with the Maintenance Contract.
- 2) It shall also ensure that the system allows all the personnel involved in the contract (including the contractors and their subcontractors) to familiarise themselves with its terms and that, for any contract amendment, the relevant information is distributed in the organisation and to the contractor.



## 2.6 Quality Audit Personnel

- 1) The quality management is exclusively subordinate to the AM. The QM works independently and must not be directly involved in the activity he/she has been asked to audit. The QM is responsible for ensuring that the Quality Programme is properly established, implemented and maintained.
- 2) The QM must have:
  - a) direct access to the AM; and
  - b) have access to all parts of GAM CAMO.
- 3) The QM has the full authority and support from GAM CAMO to perform her/his duty within the system.
- 4) The QM may delegate audits to additional auditors and/or an audit team if he/she deems it necessary. He also establishes the audit and inspection schedule to be completed during a specific calendar period according the present situation.
- 5) The task of auditing quality assurance shall be carried out by any other approved nominated auditor who is not directly related to the quality department.
- 6) The nominated auditor shall be trained in a manner to fulfil the required knowledge as required to perform quality system tasks. The minimum training required to be attended by the nominated auditor shall be as per QPM 2.8 Quality Audit Personnel.
- 7) The nominated auditor shall be assessed to ensure adequate knowledge and competence of the quality audit personnel to perform the allocated tasks effectively including monitor compliance with CAMO and TAO-M identifying non-compliance in an effective and timely manner so that the organisation may remain in compliance with TAO- M.
- 8) The independence of quality audit personnel shall be established when GAM CAMO uses skilled personnel working within another department than that of Quality.
- 9) The record of these activities shall be stored for at least three (3) years.



## **PART 3 CONTRACTED MAINTENANCE**

### **3.1 Maintenance Contractor / Tasked Organisation Selection Procedure**

- 1) Part Three (3) of the CAME describes the contracted maintenance arrangements between GAM CAMO and an DGTA AMO, on behalf of the Operators. It includes details of arrangements, together with the division of responsibility for these arrangements, between Operators and DGTA AMO or other Maintenance Contractor together with copies of the Maintenance Contracts in force for Base and Line Support, as appropriate.
- 2) This activity should be carried out in agreement with the aircraft owner.
- 3) When GAM CAMO is not a maintenance organisation approved in accordance with TAO-145, GAM CAMO shall in consultation with the owner (or in the case of lease, with the lessee), establish a written maintenance contract with a maintenance organisation approved in accordance with TAO-145 including:
  - a) Detailing the functions specified under TAO-145;
  - b) ensuring that all maintenance is ultimately carried out by a maintenance organisation approved in accordance with TAO-145; and
  - c) defining the support of the quality functions described in 2.1.A.5) of this CAME.
- 4) Notwithstanding with paragraph 3.1.3) above, the contract should be in the form of individual work orders addressed to the maintenance organisation approved in accordance with TAO-145 in the case of:
  - a) an aircraft requiring unscheduled line maintenance; or
  - b) component maintenance.
- 5) Before any contract is signed with a maintenance organisation, the CAM will verify through quality audit defined in CAME Chapter 2.4 and 2.5 that:
  - a) the maintenance organisation is appropriately approved and has the necessary qualified manpower, facilities, tooling, technical documentation etc. This verification to take into account any engine, propeller, or





Issue No.	1
Revision No.	0

- component maintenance capability that may be required (though this may be available through sub-contract to other suitably AMO);
- b) it will be confirmed that the AMO has adequate capacity to undertake the proposed maintenance support; and
  - c) the draft Maintenance Contract will be reviewed and agreed by both parties with a view to ensuring that each has the ability to discharge their responsibilities with respect to TAO-M.
- 6) The following shall be considered when developing the maintenance contract:
- a) the process to implement the different elements described in TAO-145;
  - b) responsibilities, task and interaction with the maintenance organisation and with the owner/operator;
  - c) the work order to ensure that the applicable elements of certification of maintenance are considered; and
  - d) describe when necessary, the use of work order for unscheduled line maintenance and component maintenance as per TAO-145.
- 7) The contract shall be comprehensive and that it has no gaps or unclear area. Everyone involved in the contract (both CAMO and AMO) agrees with the terms of the contract and fully understands their responsibilities. The functional responsibilities of all parties are clearly identified in the contract.
- 8) Refer CAME Chapter 5.4 for the list of contracted AMO for GAM CAMO fleet.



Issue No.	1
Revision No.	0

### **3.2 Quality Audit of Aircraft**

- 1) The purpose of a quality audit of aircraft is to ensure that all required continuing airworthiness tasks are performed on the aircraft and shall form part of the Quality Programme stated in CAME Chapter 2.1.B.
- 2) In no way may a product audit of an aircraft be confused with a periodic airworthiness review carried out by DGTA. Product audit of aircraft are tools to have a feedback on the quality level of the organisation to the management staff. Findings of product audit of aircraft do not affect the Certificate of Airworthiness but are submitted to the CAM for closure.
- 3) Product audit of aircraft are performed by the QM or by quality audit personnel according to Chapter 2.6 of this CAME with the assistance of a person having an appropriate maintenance licence for the aircraft type.
- 4) The performance of product audit of aircraft will include:
  - a) Inspections if all approved procedures are complied with.
  - b) Inspection if all maintenance was carried out in accordance with the approved AMP and maintenance contract.
  - c) Inspection if all maintenance was performed according to standard practices.
  - d) Inspection if the requirements of TAO-M are complied with.
- 5) All findings of the audit are recorded and forwarded to CAM for further management. The finding shall be closed within the time frame as stated in CAME Chapter 2.1.D.



Issue No.	1
Revision No.	0

### 3.3 Quality Audit of Sub-Contracted CAMO Tasks

- 1) Not Applicable



Issue No.	1
Revision No.	0

## **PART 4 AIRWORTHINESS REVIEW PROCEDURES**

### **4.1 Airworthiness Review Staff**

- 1) Not applicable in DGTA context.



Issue No.	1
Revision No.	0

## 4.2 Review of Aircraft Records

- 1) To satisfy the requirement for the airworthiness review of an aircraft referred to in TAO-M M.A 901 – Aircraft Airworthiness Review, a review of the aircraft records shall be carried out by the DGTA in order to be satisfied that:
  - a) airframe, engine and propeller flying hours and associated flight cycles and/or landings and any other airworthiness data as required by the DGTA, have been properly recorded; and
  - b) the aircraft flight manual and/or any other manuals required by the DGTA are applicable to the aircraft configuration and reflects the latest revision status; and
  - c) all the maintenance due on the aircraft according to the AMP has been carried out; and
  - d) all known defects have been corrected or, when applicable, carried forward in a controlled manner;
  - e) all applicable Airworthiness Directives have been applied and properly registered;
  - f) all modifications and repairs applied to the aircraft have been registered and are approved in accordance with TAO-M M.A.304 – Data for Modifications and repairs; and
  - g) all service life limited components installed on the aircraft are properly identified, registered and have not exceeded their approved service life limit; and
  - h) all maintenance has been released in accordance with TAO-M MA.801 – Certificate of Release to Service (CRS); and
  - i) the current weight and balance statement reflects the configuration of the aircraft and is valid; and
  - j) the aircraft complies with the latest revision of its type design approved by the DGTA/TC Holder; and



Issue No.	1
Revision No.	0

- k) if required, the current symmetry report reflects the configuration of the aircraft and is valid
  - l) if required any other areas/programmes.
- 2) This review shall be fully documented in TAO-M Form 15c – Airworthiness Review Report.
  - 3) The DGTA shall have unrestricted access to all aircraft records for the airworthiness review



Issue No.	1
Revision No.	0

### 4.3 Physical Survey

- 1) DGTA shall carry out a physical survey of the aircraft. For this survey, DGTA shall be assisted by such qualified/authorised personnel.
- 2) Through the physical survey of the aircraft, the DGTA auditors shall ensure that:
  - a) all required markings and placards are properly installed; and
  - b) the aircraft complies with its aircraft flight manual and/or any other manuals required by the DGTA; and
  - c) the aircraft configuration complies with the approved data; and
  - d) no evident defect can be found that could not have been reasonably expected to be addressed; and
  - e) no inconsistencies can be found between the aircraft and the review of records specified in paragraph 4.2 of this CAME; and
  - f) this review shall be fully documented in TAO-M Form 15c – Airworthiness Review Report.
- 3) By derogation to TAO-M M.A.901(a) – Aircraft Airworthiness review, the airworthiness review can be anticipated by a maximum of 90 days without loss of continuity of the airworthiness review pattern, to allow the physical survey to take a place during a maintenance check.



Issue No.	1
Revision No.	0

**4.4 Additional Procedures for Recommendations to DGTA for the Import of Aircraft/Used Aircraft**

- 1) Not applicable in DGTA context.





Issue No.	1
Revision No.	0

**4.5 Recommendation to DGTA for the Issue of a C of A Renewal**

- 1) Not applicable in DGTA context.



Issue No.	1
Revision No.	0

#### **4.6 Issuance of a C of A Renewal**

- 1) Not applicable in DGTA context.

#### **4.7 Airworthiness Review Records, Responsibilities, Retention and Access**

- 1) GAM CAMO shall retain a copy of each airworthiness review report together with all supporting document listed in Part 4 of this CAME until two (2) years after the aircraft has been permanently withdrawn from service.
- 2) The records should be stored in a safe way with regard to damage, alteration, and theft. Computer backup discs, tapes etc., should be stored in a different location from that containing the current working discs, tapes, etc., and ensure they remain in good condition in a safe environment. Retention takes place according to Chapter 1.3 of this CAME.
- 3) Where continuing airworthiness management of an aircraft is transferred to another CAMO, all retained records shall be transferred to the said CAMO. The time periods prescribed for the retention of records shall continue to apply to the said organisation.
- 4) Where GAM CAMO ceases to hold the certificate of approval under TAO-M M.A. Subpart G, all retained records shall be transferred to the owner (or in the case of lease, to the lessee) of the aircraft.



Issue No.	1
Revision No.	0

#### **4.8 C of A Renewal**

- 1) Board of State Technical Airworthiness – C of A (BoSTA – CoA) is the approving authority for C of A renewal.
- 2) Renewal of the C of A will be issued by the BoSTA for one year and shall be subjected to an annual review by the BoSTA – CoA.
- 3) The following requirements must be satisfied before C of A Renewal can be considered for renewal by the BoSTA:
  - a) The DAR/applicant shall submit C of A application form (TAO-M Form 15d) to DGTA at least 30 days before the C of A review date;
  - b) The DAR/applicant shall make the aircraft and aircraft maintenance and airworthiness documents available for DGTA audit; and
  - c) The DAR/applicant shall give a formal presentation to BoSTA – C of A for approval. The presentation shall include information pertaining to the aircraft and in a format as per TAO-M Appendix XII to AMC M.A.901 – Aircraft Airworthiness Review.



Issue No.	1
Revision No.	0

**PART 4B PERMIT TO FLY**

**4B.1** Not applicable in DGTA context.



Issue No.	1
Revision No.	0

## **PART 5 APPENDICES**

### **5.1 Sample Documents**

- 1) Forms referred to in CAME procedures:
  - a) Aircraft Technical Log AW139 (APMM/C-008/AW139)
  - b) Aircraft Technical Log AS365 (APMM/C-008/AS365N3)
  - c) Deferred Defect Record (GAM/CAMO-013)
  - d) Audit Plan (GAM/Q-007)
  - e) Audit Report (GAM/Q-009)
  - f) Audit Checklist (GAM/Q-008D)
  - g) Manpower Resources Management Tool (GAM/C-052)
- 2) All forms listed above, except for 5.1.1) a) and 5.1.1) b), shall be referred to Galaxy Aerospace Management System (GAMS) portal for the latest revision.

## Continuing Airworthiness Management Exposition (CAME)

Issue No.	1
Revision No.	0

### 3) Aircraft Technical Log AW139 (APMM/C-008/AW139)

AIRCRAFT TECHNICAL LOG														TECHNICAL LOG S/N:		00001							
 <b>MALAYSIA MARITIME ENFORCEMENT AGENCY</b> (APMM/C-008/AW139)				AIRCRAFT TYPE		REGISTRATION NO		AIRCRAFT S/N		BASE		BASIC WEIGHT		FLIGHT DATE									
				AW139		1		2		3		4		5									
FLT. NO	FUEL STATE (KG/LTRS)			ENGINE OIL (QT)		TRANSMISSION OIL (QT)			REPLENISH / PREFLIGHT / TURN AROUND / POST FLT INSP CERTIFICATE			PILOT PRE-FLIGHT / TURN AROUND											
	REMAINING	QTY UPLIFT	TOTAL FUEL ON DEPARTURE	#1 ENGINE UPLIFT	#2 ENGINE UPLIFT	MGB UPLIFT	HGB UPLIFT	TGB UPLIFT	LIC. / APP SIGN**		NO	TIME A/C READY FOR RELEASE TO FLIGHT	INDICATE A/C AS SERVICEABLE AND FUEL/OIL SUFFICIENT FOR FLIGHT INTENDED										
6	7	8	9	10	11	12	13	14	15	16	17	18	19										
FLT. NO	FROM	TO	TAKE OFF TIME	LANDING TIME	FLIGHT DURATION	ENGINE HRS		ENGINE START CYCLE		NO OF LANDING	HOIST CYCLE	CARGO HOOK	ROTOR BRAKE	FLIGHT CYCLE	DAILY INSPECTION (LAME/APP HOLDER CERTIFICATION)								
						NO 1	NO 2	NO 1	NO 2						DATE	APP/LIC. NO	NAME	SIGNATURE**					
20	21	22	23	24	25	26	27	28	29	30	31	32	33	34	38	39	40	41					
														NEXT MAINTENANCE DUE									
														DUE DATE / HRS / CYCLE									
														INSPECTION	DESCRIPTION	HRS	CYCLE	DATE					
														42	43	44	45	46					
														OUT OF PHASE SERVICING (OOP)									
														OOP INSPECTION	DUE HOURS	DUE DATE	DUE CYCLE	REMARKS					
														47	48	49	50	51					
DEFERRED DEFECT (ENTER "NIL" IF NONE) BRIEF DEFECT/TECH. LOG REF														FLT. NO	OPS MTOW > 6400KG		33 < WS < 45 KTS		45 < WS < 60 KTS		CAT.A		
DESCRIPTION DEFECT	MEL REFERENCE			LIMITATION			DUE DATE	DUE HOURS	HOURS	LDG	START	STOP	START		STOP	57	58	59	60	61		62	63
62	63			64			65	66															
FLT NO	RECORD OF DEFECT OR REQUIREMENT FOR FLIGHT/GRD. REPORT/TEST. ENTER "NIL" IF NO DEFECT FOUND			SIGN / STAMP	DATE / TIME	RECTIFICATION/WORK CARRIED OUT AND IAW REF DOC.					CERTIFICATE OF RELEASE TO SERVICE												
65	66			67	68	69					APP HOLDER NAME	APP HOLDER INITIAL**	STAMP	DATE									
											70	71	72	73									

\*\*The Work Recorded Above Has Been Carried Out In Accordance With The Requirements Of The Directorate General Technical Airworthiness (DGTA) For The Time Being and In That Respect The Aircraft/ Equipment Is Considered Fit Release To Service

ACTION	NO	SECTION	SUB-SECTION	INSTRUCTION
MAINTENANCE INSPECTION SUPERVISOR	1.	AIRCRAFT REGISTRATION	-	Registration marking of the aircraft.
	2.	AIRCRAFT SERIAL NUMBER	-	Serial number registered on the aircraft.
	3.	BASE	-	Location of the aircraft.
	4.	BASIC WEIGHT	-	Weight of the aircraft.
	5.	FLIGHT DATE	-	Date of the journey log.
	6.	FLT . NO	-	Number of flights conducted, if maintenance activity should be written "M" in front of the number.
	7.	FUEL STATE (KG/LTRS)	REMAINING	Input the fuel state of the aircraft remaining.
	8.		QTY UPLIFT	Input quantity when uplift.
	9.		TOTAL FUEL ON DEPARTURE	Input total fuel on departure.
	10.	ENGINE OIL (QT)	ENG 1	Oil quantity added to LH engine.
	11.		ENG 2	Oil quantity added to RH engine..
	12.	TRANSMISSION OIL (QT)	MGB	Input the transmission oil quantity for MGB.
	13.		IGB	Input the transmission oil quantity for IGB.
	14.		TGB	Input the transmission oil quantity for TGB.
	15.	REPLENISH / PREFLIGHT / TURN AROUND / POST FLT INSP CERTIFICATE	SIGN**	Signature of MIS in-charge.
	16.		NO	Number after replenish preflight, turnaround or post flight inspection certificate.
	17.		TIME A/C READY FOR RELEASE TO FLIGHT	Time aircraft ready to release.
PILOT	18.	PILOT PRE FLIGHT / TURN AROUND	NAME	Name of pilot in-charged.
	19.		INITIAL	Initial of pilot in-charged.
	20.	FLT. NO	-	Flight numbers.
	21.	FROM	-	Location of the aircraft during take- off.
	22.	TO	-	Location of the aircraft during landing.
	23.	TAKE OFF TIME	-	Enter time of the aircraft take-off of the day.
	24.	LANDING TIME	-	Enter time of the aircraft landing of the day.
	25.	FLIGHT DURATION	-	Enter flying hours accumulated from take-off to landing.



ACTION	NO	SECTION	SUB-SECTION	INSTRUCTION
	26.	ENGINE HRS	ENG 1	Numbers of flying hours of LH engine.
	27.		ENG 2	Numbers of flying hours of RH engine.
	28.	ENGINE START CYCLE	ENG 1	Numbers of cycle of LH engine.
	29.		ENG 2	Numbers of cycle of RH engine.
	30.	NO OF LANDING	-	Number of landings per flight activity.
	31.	HOIST CYCLE	-	Number of unreeling and recovery of the cable with load attached to the hook only (if applicable).
	32.	CARGO HOOK	-	Load cycle in every external load list using all applicable cargo hook configuration (if applicable).
	33.	ROTOR BRAKE	-	Number of rotor brake.
	34.	FLIGHT CYCLE	-	Number of flight cycle per flight activity.
MAINTENANCE INSPECTION SUPERVISOR	35.	TOTAL OF THIS PAGE	-	The total of flight duration, engine hours, engine start cycle, no of landing cargo slings cycle (if applicable) and flight cycle of the day.
	36.	TOTAL B/FWD	-	The total previous of flight duration, engine hours, engine start cycle, no of landing cargo slings cycle (if applicable) and flight cycle of the day.
	37.	TOTAL	-	The sum of the accumulations from TOTAL B/FWD add to TOTAL OF THIS PAGE.
	38..	DAILY INSPECTION (LAME/ APP HOLDER CERTIFICATION)	DATE	Date of complete activites.
	39.		APP/LIC.NO	Approval number.
	40.		NAME	Name of MIS in-charged.
	41.		SIGN**	Signature of MIS in-charged.
	42.	NEXT MAINTENANCE DUE	INSPECTION	Next maintenance inspection.
	43.		DESCRIPTION	Next maintenance description.
	44.		HOURS	Next maintenance hours.
	45.		CYCLE	Next maintenance cycle.
	46.		DATE	Next maintenance date.
	47.	OUT OF PHASE SERVICING (OOP)	OOP INSPECTION	Inspection which is not carried out during scheduled maintenance.

ACTION	NO	SECTION	SUB-SECTION	INSTRUCTION
	48.		DUE HOURS	Due hours which is not carried out during scheduled maintenance.
	48.		DUE DATE	Due date which is not carried out during scheduled maintenance.
MAINTENANCE INSPECTION SUPERVISOR	50.	OUT OF PHASE SERVICING (OOP)	DUE CYCLE	Due cycle which is not carried out during scheduled maintenance.
	51.		REMARKS	Remarks which is not carried out during scheduled maintenance.
	52.	DEFERRED DEFECT (ENTER "NIL" IF NONE) BRIEF DEFECT/TECH.LOG REF	DESCRIPTION DEFECT	Description defect by maintenance.
	53.		MEL REFERENCE	MEL reference of the defect.
	54.		LIMITATION	Limitation of the defect.
	55.		DUE DATE	Due date of the defect.
	56.		DUE HOURS	Due hours of the defect.
	PILOT	57.	FLT.NO	-
58.		OPS MTOW > 6400	HOURS	Duration for any operation exceeds MTOW 6,400kg.
59.			LANDING	Number of landing for any operation exceeds MTOW 6,400kg.
60.		33 < WS < 45 KTS	START	Number of rotor start with wind speed between 33 knots and 45 knots; value cannot exceed 1.
61.			STOP	Number of rotor stop with wind speed between 33 knots and 45 knots; value cannot exceed 1.
62.		45 < WS < 60 KTS	START	Number of rotor start with wind speed between 45 knots and 60 knots; value cannot exceed 1.
63.			STOP	Number of rotor stop with wind speed between 45 knots and 60 knots; value cannot exceed 1.
64.		CAT. A TRAINING	-	Flying hours recorded during CAT. A Training Operations.
PILOT	65.	FLT. NO	-	Number of flight conducted, if maintenance activity should be written "M" in front of the number.
	66.	RECORD OF DEFECT OR REQUIREMENT FOR FLIGHT/GRD.	-	Record of any defect occurred during the flight conducted. Write "NIL" for no defect recorded.

ACTION	NO	SECTION	SUB-SECTION	INSTRUCTION
		REPORT/TEST. ENTER "NIL" IF NO DEFECT FOUND		
	67.	SIGN/STAMP	-	Number of flying hours of RH engine.
	68.	DATE/TIME	-	Number of cycle of LH and RH engine.
MAINTENANCE INSPECTION SUPERVISOR	69.	RECTIFICATION/WORK CARRIED OUT AND IAW REF DOC	-	Approval holder fills in the rectification carried out and the reference document on defects noted by the pilot.
	70.	CERTIFICATE OF RELEASE TO SERVICE TOTAL CARRY FORWARD	APP HOLDER NAME	Name of MIS in-charged.
	71.		APP HOLDER INITIAL**	Signature of MIS in-charged.
	72.		STAMP	Stamp of MIS in-charged.
	73.		DATE	Date of complete activities.

4) Aircraft Technical Log AS365 (APMM/C-008/AS365N3)

1. AIRCRAFT STATUS	
FMC	
PMC	

**AIRCRAFT TECHNICAL LOG**



2. A/C TYPE		3. DATE		4. A/C S/N		5. A/C REGN. NO.		6. ENGINE S/N				7. DAILY CHECK (BFF)				8. AFTER LAST FLIGHT CHECK (ALF)					
AS365N3								NO. 1		NO. 2		SIGN**		STAMP		DATE & TIME		SIGN**		STAMP	DATE & TIME
9. FLIGHT NO	10. **PREFLIGHT / TURNAROUND (STAMP & TIME BY MAINT.)	11. PREFLIGHT / TURN AROUND (BY PILOT)	12. FROM	13. TO	14. TOTAL FUEL UPLIFT (KG)	15. DEPARTURE FUEL (KG)			16. Total Departure Fuel (KG)	17. HYDRAULIC (LTR)		18. OIL LEVEL (LTR)		19. ENGINE OIL DEPARTURE (LTR)		20. TAKE OFF TIME	21. LANDING TIME	22. PILOT RETURN INITIAL	23. FLIGHT TIME	24. LANDINGS	
						LH	ALDUFERRY	RH		LH	RH	MGB	TGB	NO. 1	NO. 2						
1																					
2																					
3																					
4																					
5																					
6																					
25. ENGINE HOURS		26. NG CYCLES		27. MF CYCLES		28. HOIST CYCLES		29. CARGO SLING CYCLES		30. ONE ENGINE INOPERATIVE (O.E.I.) RATING				31. TOTAL THIS PAGE		32. BROUGHT FORWARD	33. TOTAL				
NO. 1		NO. 2		NO. 1		NO. 2		NO. 1		NO. 2		NO. 1		NO. 2							
34. TOTAL THIS PAGE																					
35. BROUGHT FORWARD																					
36. TOTAL																					
37. ** 7. - 8. DAILY CHECK BFF/ALF		AIRCRAFT BFF LAW		AIRCRAFT ALF LAW		HOIST LAW		FLR LAW		LOUD SPEAKER LAW		AIRCRAFT BASIC WEIGHT (KG)									
37. FLIGHT NO	38. ITEM NO	39. RECORD OF DEFECTS OR REQUIREMENT FOR FLIGHT / GROUND REPORT / TEST ENTER 'NIL' IF NO DEFECT FOUND.			40. SIGN	41. TIME	42. RECTIFICATION / WORK CARRIED OUT AND /AW REFERENCE DOCUMENT		43. CERTIFICATE OF RELEASE TO SERVICE			44. NEXT MAINTENANCE DUE									
									SIGN**		STAMP	DATE & TIME	ITEM	HRS/DATE							
													10EE								
													25EE								

\*\*The Work Recorded Above Has Been Carried Out In Accordance With The Requirements Of The Directorate General Technical Airworthiness (DGTA) For The Time Being and In That Respect The Aircraft/ Equipment Is Considered Fit Release To Service

ACTION	NO	SECTION	SUB-SECTION	INSTRUCTION
MAINTENANCE INSPECTION SUPERVISOR	1.	AIRCRAFT STATUS	-	Tick the box for the capability of the aircraft.
	2.	AIRCRAFT TYPE	-	Type on the aircraft.
	3.	DATE	-	Date of the journey log.
	4.	AIRCRAFT SERIAL NUMBER	-	Serial number of the aircraft.
	5.	AIRCRAFT REGISTRATION	-	Registration number of the aircraft.
	6.	ENGINE S/N	NO. 1	Serial number of LH engine.
			NO. 2	Serial number of RH engine.
	7.	DAILY CHECK (BFF)	SIGN**	Signature of the MIS in-charged.
			STAMP	Stamp of the MIS in-charged.
			DATE & TIME	Date and time Before First Flight (BFF).
	8.	AFTER LAST FLIGHT CHECK (ALF)	SIGN	Signature of the MIS in-charged.
			STAMP	Stamp of the MIS in-charged.
			DATE & TIME	Date and time After Last Flight check (ALF).
	**7, **8	DAILY CHECK BFF/ALF	AIRCRAFT BFF I.A.W	Authorization holder to enter Before First Flight (BFF) check MET/ MM/ manual used for aircraft, hoist, flir, loud speaker.
AIRCRAFT ALF I.A.W				
HOIST I.A.W				
FLIR I.A.W				
LOUD SPEAKER I.A.W				
9.	FLIGHT NO	-	Flight number.	
10.	PREFLIGHT / TURNAROUND (STAMP & TIME BY MAINT.)	-	Signature and stamp of MIS in-charge after preflight or turnaround check and indicate the time.	
PILOT	11.	PRE FLIGHT / TURN AROUND (BY PILOT)	-	Name of pilot in-charged after preflight or turnaround.
	12.	FROM	-	Location of the aircraft during take- off.
	13.	TO	-	Location of the aircraft during landing.
	14.	TOTAL FUEL UPLIFT (KG)	-	Total top-up fuel is filled of by approval holder.

ACTION	NO	SECTION	SUB-SECTION	INSTRUCTION
PILOT & MAINTENANCE	15.	DEPARTURE FUEL (KG)	LH	Quantity of fuel per fuel group.
			AUX/FERRY	
			RH	
	16.	TOTAL DEPARTURE FUEL (KG)	-	Total quantity of fuel for every flight.
	17.	HYDRAULIC (LTR)	LH	If no additional. Enter 'SAT' (satisfactory) otherwise, stated quantity of engine MGB, TGB, Hydraulics oil top-up.
RH				
18.	OIL LEVEL (LTR)	MGB	If no additional. Enter 'SAT' (satisfactory) otherwise, stated quantity of engine MGB, TGB, Hydraulics oil top-up.	
		TGB		
19.	ENGINE OIL DEPARTURE (LTR)	NO. 1	If no additional. Enter 'SAT' (satisfactory) otherwise, stated quantity of engine MGB, TGB, Hydraulics oil top-up.	
		NO. 2		
PILOT	20.	TAKE OFF TIME	-	The take-off times.
	21.	LANDING TIME	-	The landing times.
	22.	PILOT RETURN INITIAL	-	Sign after returning the aircraft and turning it over to the maintenance team or the following pilot in command.
	23.	FLIGHT TIME	-	Duration of the flight times.
	24.	LANDINGS	-	Number of landings.
MAINTENANCE INSPECTION SUPERVISOR	25.	ENGINE HOURS	NO. 1	Enter the engine hours.
			NO. 2	
	26.	NG CYCLES	NO. 1	Enter the NG cycles.
27.	NF CYCLES	NO. 1	Enter the NF cycles.	
		NO. 2		
PILOT	28..	HOIST CYCLES	-	Enter the hoist cycles (if any).
	29.	CARGO SLING CYCLES	-	Enter the cargo sling cycles (if any).
	30.	ONE ENGINE INOPERATIVE (O.E.I) RATING	NO. 1	Enter the O.E.I rating (if any).
NO. 2				
MAINTENANCE INSPECTION SUPERVISOR	31.	TOTAL THIS PAGE	-	Sum of the total flight time and landing.
	32.	BROUGHT FORWARD	-	Previous technical log aircraft flight hours and landing.
	33.	TOTAL	-	Total sum of No.31 plus No.32.

ACTION	NO	SECTION	SUB-SECTION	INSTRUCTION
	34.	<b>TOTAL THIS PAGE</b>	-	The total engine hours, NG cycles, NF cycles, Hoist cycles, Cargo sling cycles (if applicable) and O.E.I rating.
	35.	<b>BROUGHT FORWARD</b>	-	Previous technical log total engine hours, NG cycles, NF cycles, Hoist cycles, Cargo sling cycles (if applicable) and O.E.I rating.
	36.	<b>TOTAL</b>	-	Total sum of No.34 plus No.35.
PILOT	37.	<b>FLIGHT NO</b>	-	Flight numbers.
	38.	<b>ITEM NO</b>	-	Item number.
	39.	<b>RECORD OF DEFECTS OR REQUIREMENT FOR FLIGHT/GROUND REPORT/TEST ENTER 'NIL' IF NO DEFECT FOUND</b>	-	Note any defect discovered in both flight and on the ground. If there is no defect found, the pilot must input NIL.
	40.	<b>SIGN</b>	-	Signature of pilot in-charged.
	41.	<b>TIIME</b>	-	Time recorded for the activities.
	MAINTENANCE INSPECTION SUPERVISOR	42.	<b>RECTIFICATION / WORK CARRIEDOUT AND IAW REFERENCE DOCUMENT</b>	-
43.		<b>CERTIFICATE OF RELEASE TO SERVICE</b>	SIGN	Signature of the MIS in-charged.
			STAMP	Stamp of the MIS in-charged.
			DATE & TIME	Date and time.
44.		<b>NEXT MAINTENANCE DUE</b>	ITEM HRS/DATE	Fill in the next maintenance due by MIS.

	<b>Continuing Airworthiness Management Exposition (CAME)</b>	
	Issue No.	<b>1</b>
	Revision No.	<b>0</b>

## 5.2 List of Airworthiness Review Staff

- 1) Not applicable in DGTA context.





Issue No.	1
Revision No.	0

### 5.3 List of Contracted/Tasked Organisation

- 1) No continuing airworthiness management tasks subcontracted for the time being in force.

#### 5.4 List of Contracted/Tasked TAO-145 AMOs

No.	Organization's Name & Address	DGTA Approval No.	Capability	Scope
1.	Galaxy Aerospace (M) Sdn. Bhd. Stesen Udara Maritim Subang Jalan TUDM 40150 Shah Alam Selangor Darul Ehsan	AMO 03/2021	AW139	Line and Base Maintenance
		AMO 10/2023	AS365N3	

	<b>Continuing Airworthiness Management Exposition (CAME)</b>	
	Issue No.	1
	Revision No.	0

**5.5 Copy of Contracts/Taskings for Contracted/Tasked Work**

- 1) No continuing airworthiness management tasks subcontracted for the time being in force.

Issue No.	1
Revision No.	0

**5.6 Copy of Contracts/Taskings with TAO-145 AMOs**

CAMO – AMO Agreement  
GALAXY AEROSPACE (M) SDN. BHD.



**AGREEMENT**

**BETWEEN**

**CONTINUING AIRWORTHINESS  
MANAGEMENT ORGANISATION  
(CAMO)**  
(Company No: 1040262-D)

**AND**

**AIRCRAFT MAINTENANCE ORGANISATION  
(AMO)**  
(Company No: 1040262-D)

**FOR**

**AIRCRAFT MAINTENANCE SUPPORT**

**AGREEMENT REFERENCE:  
GAM/CAMO-AMO/2023/01  
DATED: 25.07.2023**

GAM/CAMO-AMO/2023/01

1

CAMO – AMO Agreement  
GALAXY AEROSPACE (M) SDN. BHD.

**THIS AIRCRAFT MAINTENANCE SUPPORT AGREEMENT** is made on the 25 July 2023

This Agreement is to define the obligations of the signatories between **GAM AMO** as Approved Maintenance Organisation (AMO) for **the Helicopter** as defined in Attachment 1 and **GAM CAMO** as the Continuing Airworthiness Management Organisation (CAMO). This Agreement is to define the obligations of the signatories required by Directorate General Technical Airworthiness (DGTA) and bears no commercial significance.

NOW, THEREFORE, **GAM CAMO** AND **GAM AMO**, FOR THE CONSIDERATION HEREINAFTER SET FORTH, AS GUIDED BY DGTA TAO-M HEREBY AGREED AS FOLLOWS: -

**CLAUSE 1 SCOPE OF WORK**

- 1.1. The helicopter is maintained in accordance with DGTA approved maintenance programme reference MMEA/CAMO/AMP/AW139 & MMEA/CAMO/AMP/AS365N3 latest revision.
- 1.2. GAM CAMO shall provide the applicable supporting documentation to GAM AMO for planning scheduled maintenance checks. This may include, but may not be limited to:
  - 1) Work package, including work order, worksheet, and work card.
  - 2) Scheduled component removal list.
  - 3) Modifications incorporated.
  - 4) Airworthiness Directives / Service Bulletin
- 1.3. GAM AMO shall return the maintenance work package to GAM CAMO no later than 7 working days after maintenance completion.

**CLAUSE 2 MAINTENANCE DATA**

- 2.1 **GAM CAMO** shall make the latest revision of maintenance data required for the purpose of this Agreement available at all times may include, but not limited to:
  - 1) maintenance programme,
  - 2) airworthiness directives,
  - 3) major repairs/modification data,
  - 4) aircraft maintenance manual,
  - 5) aircraft illustrated parts catalogue (IPC),
  - 6) wiring diagrams,
  - 7) troubleshooting manual
  - 8) flight manual,
  - 9) engine maintenance manual,
  - 10) engine overhaul manual

**CLAUSE 3 UNSCHEDULED MAINTENANCE/ DEFECT RECTIFICATION**

- 3.1. GAM AMO is responsible to inform GAM CAMO if any defect found on the aircraft and its

CAMO – AMO Agreement  
GALAXY AEROSPACE (M) SDN. BHD.

and its components. GAM AMO shall inform GAM CAMO for any maintenance task that needs to be deferred and must be formally agreed by CAMO and Operator.

- 3.2. GAM CAMO shall provide the following rectification instruction to GAM for any defect/ findings raised.
- 3.3. GAM CAMO is responsible for management of approval of repairs and GAM AMO is responsible for the incorporation of repairs.

**CLAUSE 4 DEFERRED TASKS**

- 4.1. GAM AMO shall inform GAM CAMO for any maintenance task that needs to be deferred and must be formally agreed by CAMO and DAR.

**CLAUSE 5 DEVIATION FROM THE MAINTENANCE PROGRAMME**

- 5.1. GAM CAMO is responsible to manage the request of any deviation from Maintenance Programme in accordance with DGTA agreed procedure.
- 5.2. GAM AMO shall provide the necessary input and documents to substantiate the deviation request.

**CLAUSE 6 RELEASE TO SERVICE DOCUMENTATION**

- 6.1. GAM AMO is responsible to perform release to service of aircraft and its components as defined in MMP/MOE, as applicable, associated to DGTA approval no. AMO 03/2021 & AMO 10/2023. GAM AMO shall provide GAM CAMO the completed relevant support forms and documentations upon delivery of the aircraft within specified timespan by GAM CAMO. This may include but may not limited to
- 1) certificate of release to service,
  - 2) flight test report,
  - 3) list of modifications embodied,
  - 4) list of repairs,
  - 5) list of ADs accomplished,
  - 6) maintenance visit report,
  - 7) test bench report.

**CLAUSE 7 WORK SCOPE PLANNING MEETING**

- 7.1. GAM CAMO and GAM AMO may organise work scope planning meeting major defects found during maintenance check and any other relevant matter for the interval of no more than 6 months so that the tasks to be performed may be commonly agreed.
- 7.2. Any party shall notify the other party of the meeting, 10 working days in advance. Both parties

Issue No.	1
Revision No.	0

CAMO – AMO Agreement  
GALAXY AEROSPACE (M) SDN. BHD.

shall give their full commitment towards the proposed meeting.

**CLAUSE 8 RELIABILITY MEETINGS**

- 8.1. In the event of reliability programme exists, GAM CAMO is responsible to control the reliability programme. GAM CAMO shall organise reliability programme meeting every month
- 8.2. GAM AMO is responsible to provide any relevant input necessary to complete the reliability programme.
- 8.3. Both parties shall give their full commitment towards the proposed meeting.

**CLAUSE 9 DURATION OF AGREEMENT**

- 9.1. This Agreement shall become effective at the signature date by both Parties and shall remain in effect provided that the master maintenance contract with the Malaysian Maritime Enforcement Agency (MMEA) remains valid.

Issue No.	1
Revision No.	0

CAMO – AMO Agreement  
GALAXY AEROSPACE (M) SDN. BHD.

IN WITNESS WHEREOF, **GAM CAMO** and **GAM AMO** have caused this Agreement to be executed in their names by their duly authorized representatives on the date first above written.

**CONTINUING AIRWORTHINESS  
MANAGER**

**SENIOR MAINTENANCE MANAGER**

Name :   
 Designation : **ZATY NADHIRA BINTI MOHAMMED ZUHARI**  
 Continuing Airworthiness Management Manager  
 Galaxy Aerospace (M) Sdn Bhd  
 (1040262-D)  
 Date : 26/07/2023

Name :   
 Designation : **NURUL AZHAN B. SALLEHUDDIN**  
 Senior Maintenance Manager (SMM)  
 Galaxy Aerospace (M) Sdn Bhd  
 (1040262-D)



CAMO – AMO Agreement  
GALAXY AEROSPACE (M) SDN. BHD.

**ATTACHMENT 1**

AIRCRAFT TYPE	AIRCRAFT REGISTRATION	A/C SERIAL NO.
Leonardo S.p.A AW139	M72-01	31307
	M72-02	31315
	M72-03	31316
Airbus Helicopters AS365N3	M70-01	6723
	M70-02	6737
	M70-03	6741

## 5.7 List of Operating Organisations to whom CAMO provides the Management of the Continuing Airworthiness of The Aircraft

No	Aircraft Owner / Operator	Aircraft Type	Aircraft Registration	Serial Number	CAMO Contract Ref.
1.	Malaysia Maritime Enforcement Agency	AW139	M72-01	31307	APMM.JUTRA.300-4/6/4 (46)
2.			M72-02	31315	
3.			M72-03	31316	
4.		AS365N3	M70-01	6723	
5.			M70-02	6737	
6.			M70-03	6741	

## 5.8 Copy of Continuing Airworthiness Arrangements with Operating Organisations



**AGENSİ PENGUATKUASAAN MARİTİM MALAYSIA**  
KEMENTERIAN DALAM NEGERI  
Aras 4-12, One IOI Square  
IOI Resort  
62502 PUTRAJAYA



Tel. : 603-8995 7000  
Faks : 603-8941 4000  
Web : <http://www.mmea.gov.my>

Ruj Kami: APMM.JUTRA.300-4/6/4 (16)  
Tarikh: 03 Ogos 2023

Pengarah Urusan  
Galaxy Aerospace (M) SDN. BHD.  
11-14 Helicopter Centre  
Malaysian International Aerospace Center  
Sultan Abdul Aziz Shah Airport  
47200 SUBANG

YBhg. Tuan,

**PERJANJIAN PERLAKSANAAN PERKHIDMATAN CONTINUING AIRWORTHINESS MANAGEMENT ORGANISATION (CAMO) BAGI PESAWAT AW139 DAN AS365N3 MILIK AGENSİ PENGUATKUASAAN MARİTİM MALAYSIA (APMM)**

Rujuk:

A. APMM.JUTRA.300-4/6/4 (46) bertarikh 14 Dis 2022.

Dengan segala hormatnya, saya ingin menarik perhatian tuan kepada perkara dan rujuk di atas.

2. Bagi memenuhi keperluan pelaksanaan perkhidmatan CAMO seperti dikeperluan *Technical Airworthiness Order (TAO) Part M*, bersama-sama ini disertakan perjanjian persefahaman yang telah ditandatangani oleh pihak Cawangan Kejuruteraan Udara APMM dan pihak CAMO Manager syarikat Galaxy Aerospace Malaysia (GAM) Sdn. Bhd.

3. Dengan wujudnya perjanjian persefahaman di atas, amat diharapkan kedua-dua pihak, APMM dan Syarikat GAM dapat memenuhi keperluan regulasi TAO Part M yang telah ditetapkan bagi menjamin tahap pengurusan *airworthiness* pesawat AW139 dan AS365N3 milik APMM berada ditahap tertinggi.



Issue No.	1
Revision No.	0

4. Kerjasama dari pihak tuan didahului dengan ucapan terima kasih.

**" MALAYSIA MADANI"  
"BERKHIDMAT UNTUK NEGARA"  
"MENGAWAL, MELINDUNG, MENYELAMAT"**

Saya yang menjalankan amanah,

**KOMANDER (M) MOHD RAIS BIN HAJI OTHMAN**  
Ketua Penolong Pengarah Kejuruteraan Udara  
b/p Ketua Pengarah

**Disertakan:** Perjanjian Persefahaman Pelaksanaan CAMO  
Pesawat AW139 dan AS365N3 Milik APMM

**Salinan:**

**Luar:**

**Makluman:**

Directorate General Technical Airworthiness  
D/a Pangkalan Udara Subang  
40000 SHAH ALAM  
*Technical Airworthiness Regulator (TAR)*

**Dalam:**

**Makluman:**

Pengarah Kejuruteraan

**Perjanjian Persefahaman Pelaksanaan Continuing Airworthiness  
Management Organisation (CAMO) Pesawat AW139 dan AS365N3 Milik  
APMM**

**1) Senarai pesawat**

NO.	AIRCRAFT REG.	AIRCRAFT TYPE	SERIALNUMBER	ENGINE TYPE
1	M72-01	AW139	31307	PWC PT6C-67C
2	M72-02	AW139	31315	PWCPT6C-67C
3	M72-03	AW139	31316	PWC PT6C-67C
4	M70-01	AS365N3	6723	SAFRAN ARRIEL 2C
5	M70-02	AS365N3	6737	SAFRAN ARRIEL 2C
6	M70-03	AS365N3	6741	SAFRAN ARRIEL 2C

**2) Operating Organisation**

Agensi Penguatkuasaan Maritim Malaysia  
Kementerian Dalam Negeri  
Aras 4-11, One IOI Square, IOI Resort,  
62502 PUTRAJAYA

**3) TAO-M CAMO**

Galaxy Aerospace (M) Sdn. Bhd.  
Suite 11 – 14, Helicopter Centre  
Malaysia International Aerospace Centre  
Lapangan Terbang Sultan Abdul Aziz Shah  
47200 Subang

**4) Arrangement**

The Operating Organisation entrusts to the CAMO the management of the continuing airworthiness of the aircraft, the development of an Aircraft Maintenance Programme that shall be approved by the DGTA (if applicable), and the organisation of the maintenance of the aircraft according to the Aircraft Maintenance Programme in a DGTA Approved

Issue No.	1
Revision No.	0

Maintenance Organisation or equivalent. According to the present arrangement, both signatories undertake to follow the respective obligations of this arrangement.

The Operating Organisation certifies, to the best of their belief that all the information given to the CAMO concerning the continuing airworthiness of the aircraft is and will be accurate and that the aircraft will not be altered without prior approval of the CAMO.

In case of any non-conformity with this arrangement, by either of the signatories, it will become invalid. In such a case, the Operating Organisation will retain full responsibility for every task linked to the continuing airworthiness of the aircraft and the Operating Organisation shall inform the DGTA 'as soon as possible'.

**5) Obligations of the CAMO - GAM**

- a) have the aircraft type(s) in the scope of its approval;
- b) respect the conditions to maintain the continuing airworthiness of the aircraft in accordance with TAO-M M.A.708;
- c) inform the DGTA whenever the aircraft is not presented to the DGTA AMO by the Operating Organisation as requested by the CAMO;
- d) inform the DGTA whenever the present arrangement has not been respected;
- e) carry out all applicable mandated occurrence reporting; and
- f) inform the DGTA whenever either party terminates the present arrangement.

**6) Obligations of the Operating Organisation - APMM**

- a) have a general understanding of the approved maintenance programme;
- b) have a general understanding of TAO-M;
- c) present the aircraft to the DGTA AMO agreed with the CAMO at the due time designated by the CAMO's request;
- d) not modify the aircraft without first consulting the CAMO;
- e) inform the CAMO of all maintenance exceptionally carried out without the knowledge and control of the CAMO;

Issue No.	1
Revision No.	0

- f) report to the CAMO through the aircraft technical log/aircraft continuing airworthiness record system all defects found during operations;
- g) inform the DGTA whenever either party denounces the present arrangement;
- h) inform the DGTA and the CAMO whenever the Operating Organisation no longer operates the aircraft;
- i) carry out all applicable mandated occurrence reporting; and
- j) inform on a regular basis the CAMO about the aircraft flying hours and any other utilisation data, as agreed with the CAMO.

IN WITNESS WHEREOF, APMM AND GAM have caused this Agreement to be executed in their names by their duly authorised representatives on the date first above written.

**OPERATING ORGANISATION**  
(Agensi Penguatkuasaan Maritim Malaysia)

**CAMO**  
(Galaxy Aerospace (M) Sdn.Bhd.)



Name: **KDR (M) MOHD RAIS BIN HAJI OTHMAN**  
 Designation: **Ketua Penolong Pengarah Bahagian Kejuruteraan**  
 Date: **03/08/23**  
Agensi Penguatkuasaan Maritim Malaysia  
Kementerian Dalam Negeri



Name: **ZATY NADHIRA BINTI MOHAMMAD ZUHARI**  
 Designation: **Continuing Airworthiness Management Manager**  
 Date: **03 AUG 2023**  
Galaxy Aerospace (M) Sdn Bhd  
(1040262-B)

## 5.9 Manpower Resources and Management Tool

1) The planning of man hours is calculated based on the available man hours against the required man hours.

a) Available Man Hours

(1) These are the amount of man hours for personnel able to work (working hours). The working hours for GAM CAMO personnel are:

Time : 0830 hours – 1730 hours  
Break : 1 hour  
Duration : 8 hours

(2) Thus, the amount of work for a day is 8 hours for each personnel. Based on the company working days, 5 days a week, the available working hours for one personnel in a year, 52 weeks, is:

$[52 \text{ (weeks/year)} \times 5 \text{ (days/weeks)} \times 8 \text{ (hours/day)}] - [14 \text{ (Annual Leaves/year)} \times 8 \text{ (hours/day)}] - [7 \text{ (Medical Leave/year (50\% utilisation)} \times 8 \text{ (hours/day)}] - [18 \text{ (Public Holiday/year)} \times 8 \text{ (hours/day)}] - [260 \text{ (unproductive hours/year)}] = \mathbf{1508 \text{ hours/year}}$

b) Required Man Hours

(1) These are the man hours for a CAMO personnel to complete a particular task. The man hours are then total up to achieve the required man hours for each personnel within GAM CAMO.

(2) The required man hours are the amount of a personnel working hours that has to be provisioned in this department in order to accomplish all the work and functions as detailed in this chapter. The required man hours can be referred to Form GAM/C-052.



**1 GAM-CAMO FLEET**

YEAR	AC TYPE	QTY	REMARKS
2023	AW139	3	
	AS365N3	3	
<b>TOTAL AIRCRAFT</b>	-	6	
<b>AC/YEAR</b>	-	6	
<b>AC TYPE/YEAR</b>	2	-	

**2 MANPOWER**

	AVAILABILITY				
	HOURS /DAY	HOURS /WEEK	HOURS /YEAR		
<b>MANAGEMENT</b>					
ACCOUNTABLE MANAGER	3	15	566		
CAMM	2	10	377		
DEPUTY CAMM	2	10	377		
QAM	4	20	754		
			<u>2074</u>		
<b>QUALITY ASSURANCE</b>					
QA1 1	8	40	1508	REQUIRED HOURS	956
				REMAINING HOURS	552
			<u>1508</u>	STATUS	SATISFACTORY
<b>TECHNICAL SERVICE</b>					
TS 1	8	40	1508	REQUIRED HOURS	1346
				REMAINING HOURS	162
			<u>1508</u>	STATUS	SATISFACTORY
<b>CAMO PLANNER</b>					
CP 1	8	40	1508	REQUIRED HOURS	2953
CP 2	8	40	1508	REMAINING HOURS	63
			<u>3016</u>	STATUS	SATISFACTORY
<b>TECHNICAL RECORD</b>					
TR 1	8	40	1508	REQUIRED HOURS	2917
TR 2	8	40	1508	REMAINING HOURS	99
			<u>3016</u>	STATUS	SATISFACTORY
<b>TECHNICAL PUBLICATION</b>					
TP 1	8	40	1508	REQUIRED HOURS	797
				REMAINING HOURS	711
			<u>1508</u>	STATUS	SATISFACTORY

**3 CONTINUING AIRWORTHINESS MANAGEMENT ACTIVITIES**

**A. QUALITY ASSURANCE DEPARTMENT**

SECTION	TASK (JOB DESCRIPTION)	MHR /TASK	NO/MTH	AC/MTH	NO OR AC/YEAR	TOTAL MHR /MONTH	TOTAL MHR /YEAR	REMARKS
QA	Establish Annual Audit Plan	4			1		4	
	Internal audit for CAMO	16			6		96	
	Annual audit of contracted AMO	16			2		32	AMO: GAM,
	Audit report and NCR issuance	8			30		240	
	Review of amendment of CAME	8			2		16	
	Review of issuance /amendment of AMP & MEL	8			6		48	
	Liaison with authorities	2			10		20	
	Certifying Staff personal file	4			35		140	
GENERAL	Meeting (External)	4	4			16	192	
	Meeting (Internal)	2	4			8	96	
	Training - Continuous	8			4		32	
	Attend Internal/External Request	8			5		40	
<b>TOTAL</b>							<b>956</b>	

**B. TECHNICAL SERVICE DEPARTMENT**

SECTION	TASK (JOB DESCRIPTION)	MHR /TASK	NO/MTH	AC/MTH	NO OR AC/YEAR	TOTAL MHR /MONTH	TOTAL MHR /YEAR	REMARKS
TECHNICAL SERVICE	TIC Sentencing	2			80		160	
	AMP Development	64			2		128	Average 2 AC type/year
	AMP Revision	32			2		64	2 AMP
	MEL Development	64			2		128	Average 2 AC type/year
	MEL Revision	32			2		64	2 MEL
	AFTS Development	24			0		0	
	MFTS Development	24			2		38	Average 2 AC type/year
	Reliability Report	8			6		48	2 aircraft type
	Mod Record Book	16			6		96	
	Technical Query	4	2			8	96	
	Aircraft Damage Report	4	2			8	96	
	HUMS	2	2			4	48	
	Modification Assessment	16			1		16	
	Repair Assessment	16			1		16	
	Technical Notes	16			1		16	
	Weighing Activities	16			1.5		24	Total Aircraft / 4 year
Supplement Applicability	2			6		12		
Dent and Buckle Chart	4			6		24		
GENERAL	Training -GEN FAM	24			1		24	GENFAM (3 days) x 1 per year
	Training - Continuous	8			4		32	
	Aircraft Visit	4	2			8	96	
	Meeting (External)	4	1			4	48	
	Meeting (Internal)	2	3			6	72	CAMO - 2/MONTH TECH SERV - 1/MONTH
<b>TOTAL</b>							<b>1346</b>	

**C. CAMO PLANNING DEPARTMENT**

SECTION	TASK (JOB DESCRIPTION)	MHR /TASK	NO/MTH	AC/MTH	NO OR AC/YEAR	TOTAL MHR /MONTH	TOTAL MHR /YEAR	REMARKS
CAMO PLANNING	Aircraft Register	1			6		6	
	Set Up Aircraft Configuration Module	160			2		251	Average 2 AC type/year
	Aircraft induction bridging to AERONET	40			6		240	
	Monitor AERONET	4		6		24	288	
	Maintenance Forecast	4		6		24	288	
	Liaison with operator	4		6		24	288	
	TIC implementation	1		6		6	72	
	Update AD/SB in AERONET	1		6		6	72	
	AMO Coordination	4		6		24	288	
	Initiate spare request for AD/SB implementation	1		6		6	72	
	Work Order Issuance	2			60		120	Average 60 WO/year
	Workpack review and acceptance	4			60		240	Average 60 WO/year
	AJL review and acceptance	1	18			18	216	Average 20 AJL/month
	Update AERONET Tech Log Module	1	18			18	216	
Update AERONET Aircraft Module	2			60		120		
GENERAL	Training -GEN FAM	24			1		24	GENFAM (3 days) x 1 per year
	Training - Continuous	8			4		32	
	Meeting (External)	4	1			4	48	
	Meeting (Internal)	2	3			6	72	CAMO - 2/MONTH PLANNER - 1/MONTH
<b>TOTAL</b>							<b>2953</b>	

D. TECHNICAL RECORD DEPARTMENT

SECTION	TASK (JOB DESCRIPTION)	MHR /TASK	NO/MTH	AC/MTH	NO OR AC/YEAR	TOTAL MHR /MONTH	TOTAL MHR /YEAR	REMARKS
TECHNICAL RECORD	Transfer AJL data to logbook	1	18			18	216	Average 18 AJL/month
	Scan AJL	1	18			18	216	Average 18 AJL/month
	AJL filing	1	18			18	216	Average 18 AJL/month
	All logbook identification	1			18		18	Aircraft + engine
	Update aircraft log book	5		6		30	360	
	Update engine log book	2		12		24	288	Average 2 eng/aircraft
	Update prop log book	1		0		0	0	
	Update APU log book	1		0		0	0	
	Update component log card	2		6		12	144	
	Update MRB	6		6		36	432	
	Update AD Compliance to CAAM	1		6		6	72	
	Update Certificate Files	2			6		12	
	Scan Work package	4			60		240	
	Work package Filing	2			60		120	
	Record access control	1			6		6	
	Storage Facilities Labelling	1			5		5	No of shelves/ compartment
	Facilities Inspection	1	2				2	2 facilities
	Update Record Inventory	1		6			6	72
Update backup harddisk	1		6			6	72	
Scan all records - Aircraft Induction	40				6		240	Average 5 AC/year
GENERAL	Training -GEN FAM	24			1		24	GENFAM (3 days) x 1
	Training - Continuous	8			4		32	
	Meeting (Internal)	2	3			6	72	CAMO - 2/MONTH RECORD - 1/MONTH AC INDUCTION DOC ACCEPTANCE
	Attend Internal/External Request	4			9		36	
<b>TOTAL</b>							<b>2917</b>	

**E. TECHNICAL PUBLICATION DEPARTMENT**

SECTION	TASK (JOB DESCRIPTION)	MHR /TASK	NO/MTH	AC/MTH	NO OR AC/YEAR	TOTAL MHR /MONTH	TOTAL MHR /YEAR	REMARKS
TECHNICAL PUBLICATION	Publication Purchase, Renewal, Subscription	2			10		20	Average 30 Pub/year
	Publication Register	1			80		80	Average 80 Pub/year
	Raise TIC	1			80		80	Average 80 TIC/year
	External Publication Distribution	1			80		80	Average 80 Pub/Year
	Upload into server and controlled computer	2			80		160	
	Make copies of publication for controlled holder	4			12		48	Average 12 Pub/Year
	Internal Publication Distribution	2			6		12	
	Filing of signed Document Acceptance Statement	1			12		12	2 Document/Internal Pub
	Update Publication Master List	2	3			6	72	2 type + 1 internal
	Update backup harddisk	1	3			3	36	2 type + 1 internal
	Publication Control and Access	1			3		3	2 type + 1 internal
	Flight Manual Amendment	4			6		24	
	Supplement Applicability	1			6		6	
GENERAL	Training -GEN FAM	24			1		24	GENFAM (3 days) x 1 per year
	Training - Continuous	8			4		32	
	Meeting (Internal)	2	3			6	72	CAMO - 2/MONTH PUB - 1/MONTH
	Attend Internal/External Request	4			9		36	AC INDUCTION DOC ACCEPTANCE
<b>TOTAL</b>							<b>797</b>	