



# WORK ORDER



**To:** GALAXY AEROSPACE (M) SDN. BHD.

**Address:** Lot 11-14, MRO Centre, Malaysia  
International Aerospace Centre, SAAS Airport,  
Subang  
Malaysia

**Attention:** Mr. Syafrul Yamani  
Engineering Manager  
syafrul@galaxyaerospace.my

**Work Order Number:** 2023-17379

**Work Pack Reference:** 9M-PMD-17379

**Date Issued:** 20/10/2023

**A/C Registration / SN:** 9M-PMD/31809

**Sheet:** 1 OF 1

**Description:**

Item	Description/Task/Inspection	Reference	Man Hours
1	AIRWORTHINESS CHECK DUE AT: NOVEMBER 2023	AMPI 39-A-05-00-00-00A-028E-P AIRCRAFT MAINTENANCE PROGRAM AMP NO. RMPAOF/CAMO/AMP/AW139 ISSUE 3 REV. 0, CHAP 17.	<u>1.0</u> (PLEASE ADVISE)

**Remark/Notes:**

1. State this Work Order reference on your Work Package. Should there is any additional job/defect (unless specified in the work package) the maintenance organization must notify GAM Continuing Airworthiness Manager prior to proceed with rectification.
2. Work must be carried out in accordance with approved data and perform by qualified personnel/ approved LAE from the maintenance organization.
3. Parts used must be written in Parts Report Form and accompanied by ARC, Serviceable Label or equivalent document.
4. Test report, parameter reading or any supporting data must be attached with the worksheet if applicable.
5. The maintenance organization shall be responsible for any damages made on the aircraft/ components during maintenance.
6. Softcopy of completed Work Package shall be submitted or as mutual agreed and GAM Continuing Airworthiness Manager must be informed once the aircraft is Release to Service.
7. Completed Work Package (original) must be submitted to GAM Continuing Airworthiness Manager office within 3 days of date of completion.

I hereby declare that an approved and up to date maintenance data has been referred for the issuance of this work order.

Thank you.  
Best Regards,

Zaty Nadhira Mohamed Zuhari  
Continuing Airworthiness Management Manager  
Email: zaty@galaxyaerospace.my



CLIENT/OWNER: ROYAL MALAYSIA POLICE AIRCRAFT TYPE: AW139 REGISTRATION: 9M-PMD BASE/FACILITY: WMSA DATE IN: 1/11/23    OUT: 30/11/23	SERIAL NO.	HOURS	LDG/CYCLE		WORKPACK NO:	9M-PMD-17379
	AIRCRAFT	31809	1850:20	3230	WORK/INSP/DESC:	AIRWORTHINESS CHECK
	#1 ENGINE:	PCE-KB2112	1850:20	-	AERONET JOB NO.:	2023-17379
	#2 ENGINE:	PCE-KB2092	1850:20	-	AJL REF NO.:	-
				NG / N1	NF / N2	SHEET: 1 OF 1

Reason for raising: AIRWORTHINESS CHECK PERFORM I.A.W AIRCRAFT MAINTENANCE PROGRAM RMPAOF/CAMO/AMP/AW139 ISSUE 3 REV. 0 DATED 03 FEB 2021 OR LATER APPROVED REVISIONS.	Raised by and date: CAMO; Hanis 20/10/2023	Other requirements/information: NIL
---	--	--

List of scheduled inspection and all work carried out under this workpack including individual reference			DATE INSPECTION COMPLETED	Master Signature Schedule		
NO.	INSPECTION / WORK	WORKSHEET REF		NAME	SIGNATURE	APP/STAMP
1	AIRWORTHINESS CHECK	17379-001	30/11/23	FARIS	[Signature]	[Stamp M085]
				MUHAMMAD	[Signature]	[Stamp M074]
				IBRAHIM	[Signature]	[Stamp M050]
				TG. AHMAD	[Signature]	[Stamp M071]
				ZHAFRAN	[Signature]	[Stamp M131]
				ANAS NALI	[Signature]	[Stamp M092]
				ABGAS	[Signature]	[Stamp M099]
				ANUDIN	[Signature]	[Stamp M108]
				NAZIPI	[Signature]	[Stamp M084]
				P. SURESH	[Signature]	[Stamp M084]

**Galaxy Aerospace (M) Sdn. Bhd.**

*I hereby certify the following task has been performed and found satisfactory:*

1) All the tools and equipment used for maintenance has been removed from aircraft.    2) All the access panels removed for maintenance access has been reinstalled.    3) All the excess spares and materials have been notified to AMO Planner for return plan.    4) FOD check has been done.

Sign & Stamp: [Signature] [Stamp M108]    Date & Time: 30/11/23 @ 1730

<b>PART 145 - AMO RELEASE STATEMENT</b> THIS IS TO CERTIFY THAT ALL WORK LISTED ABOVE HAS BEEN INSPECTED AND ACCOMPLISHED IN ACCORDANCE WITH CONTRACTED AMO EXPOSITION AND PROCEDURE LATEST REVISION, AND <b>AMO/2016/02</b> <input checked="" type="checkbox"/> * OEM PUBLICATION REVISION AS PER REASON FOR RAISING ABOVE <input type="checkbox"/> * IF DIFFERENT FROM ABOVE, OEM PUBLICATION REVISION..... <input type="checkbox"/> * TICK ✓ WHERE APPLICABLE	NAME	ANUDIN	
	SIGN & APPROVAL	[Signature] [Stamp M108]	
	FIRM	Galaxy	
	DATE	30/11/23	
<b>PART M - CAMO ACCEPTANCE STATEMENT</b> THIS IS TO CERTIFY THAT THE ABOVE MENTIONED WORK PACKAGE HAS BEEN REVIEWED, CHECKED FOR COMPLETION AND UPDATED IN THE MAINTENANCE SOFTWARE.	NAME	SIGN & APPROVAL	DATE

# Tools Report



<b>Aircraft Serial No:</b>	31809	<b>Work Pack No:</b>	9M-PMD-17379
<b>Aircraft Type:</b>	AW139	<b>DESC:</b>	AIRWORTHINESS
<b>Aircraft Reg:</b>	9M-PMD	<b>PAGE:</b>	1 OF 1

Description	Part No	Serial Number	Worksheet Ref No. / Item No.	Calibration Due Date
-------------	---------	---------------	------------------------------	----------------------



CLIENT/OWNER: ROYAL MALAYSIA POLICE AIRCRAFT TYPE: AW139 REGISTRATION: 9M-PMD BASE/FACILITY: WMSA DATE IN: REFER WORKPACK OUT: REFER WORKPACK	SERIAL NO.	HOURS	LDG/CYCLE	WORKSHEET NO:	17379-001		
	AIRCRAFT	31809	REFER WORKPACK		WORK/INSP/DESC:	AIRWORTHINESS CHECK	
	#1 ENGINE:	PCE-KB2112	REFER WORKPACK		WORKPACK REF:	9M-PMD-17379	
	#2 ENGINE:	PCE-KB2092	REFER WORKPACK		AJL REF NO.:	REFER WORKPACK	
				NG / N1	NF / N2	SHEET:	1 OF 13

Reason for raising: AIRWORTHINESS CHECK PERFORM I.A.W AIRCRAFT MAINTENANCE PROGRAM RMPAOF/CAMO/AMP/AW139 ISSUE 3 REV. 0 DATED 03 FEB 2021 OR LATER APPROVED REVISIONS. DUE AT: <b>NOVEMBER 2023</b>	Raised by and date: CAMO; Hanis 20/10/2023	Other requirements/information: PLEASE NOTE "NIL FLYING" ON THE DATE AIRCRAFT NOT FLYING AND NOT CARRIED OUT.
--	--	--

NO.	ITEM	INSPECTION REQUIREMENT	REMARKS:
-----	------	------------------------	----------

REFERENCE SHALL BE MADE TO:

A) AW139 AMPI 05-21-00 AIRFRAME – SCHEDULE MAINTENANCE  
 B) SECTION 2 – NORMAL PROCEDURES ROTORCRAFT FLIGHT MANUAL  
 C) SECTION 5 – OPTIONAL EQUIPMENT SUPPLEMENTS ROTORCRAFT FLIGHT MANUAL

**PRE-FLIGHT/BEFORE FIRST FLIGHT INSPECTION** IS ONE OF THE ELEMENTS IN **AIRWORTHINESS CHECKS** AND IT INVOLVES VISUAL CHECK TO ENSURE THE AIRCRAFT READINESS FOR FLIGHT. THE INSPECTION IS DETAILED UNDER REMARKS SECTION IN THIS MAINTENANCE PROGRAMME, UPON COMPLETION OF THE INSPECTION, A SIGNED ENTRY MUST BE MADE IN THE JOURNEY LOG.

- BASIC INSPECTION TASKS REQUIRED ARE:
- A. PRE-FLIGHT INSPECTION  
 -TASK TO BE CARRIED OUT BEFORE EACH FLIGHT. NOTED IN REMARK AS PF
  - B. BEFORE FIRST FLIGHT  
 -TASK TO BE-CARRIED OUT ONLY BEFORE THE FIRST FLIGHT OF THE DAY. NOTED IN REMARKS AS BFF
  - C. AFTER LAST FLIGHT  
 -TASK TO BE PERFORMED AFTER THE LAST FLIGHT OF THE DAY. NOTED IN REMARKS AS AC

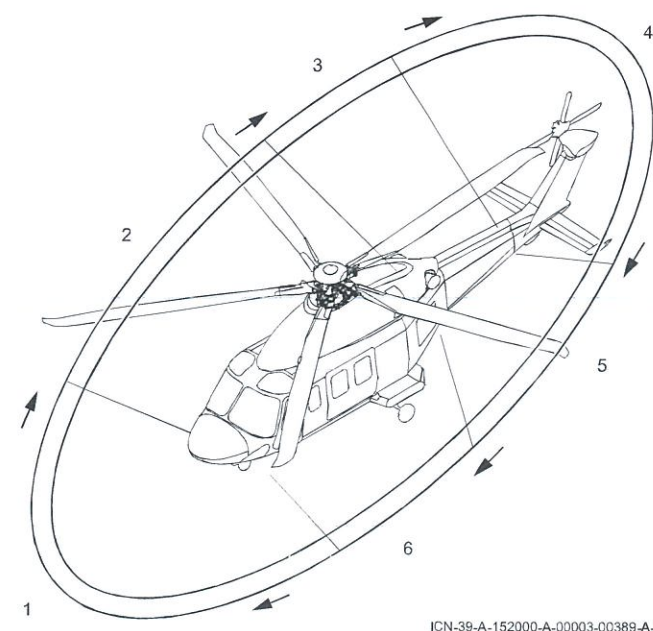

ICN-39-A-152000-A-00003-00389-A-01-1

**ZONING (AREA) ON AIRCRAFT**

\*Certifies that the work specified above, except as otherwise specified, was carried out in accordance with CAA Malaysia Requirements and in respect to that work the aircraft / aircraft component is considered ready for release to service. **AMO/2016/02**

\*Certifies that the work specified above, except as otherwise specified, was carried out in accordance with \_\_\_\_\_ and in respect to that work the aircraft / aircraft component is considered ready for release to service.

TICK ✓ WHERE APPLICABLE

FORM	ISS	DATE	REV	BY	CHK	APP	REVISION	REVISION	REVISION	REVISION	REVISION	REVISION	REVISION	REVISION	REVISION	REVISION	REVISION	REVISION	REVISION
------	-----	------	-----	----	-----	-----	----------	----------	----------	----------	----------	----------	----------	----------	----------	----------	----------	----------	----------



CLIENT/OWNER: ROYAL MALAYSIA POLICE AIRCRAFT TYPE: AW139 REGISTRATION: 9M-PMD BASE/FACILITY: WMSA DATE IN: REFER WORKPACK. OUT: REFER WORKPACK	SERIAL NO.	HOURS	LDG/CYCLE	WORKSHEET NO:	17379-001	
	AIRCRAFT	31809	REFER WORKPACK		WORK/INSP/DESC:	AIRWORTHINESS CHECK
	#1 ENGINE:	PCE-KB2112	REFER WORKPACK		WORKPACK REF:	9M-PMD-17379
	#2 ENGINE:	PCE-KB2092	REFER WORKPACK		AJL REF NO.:	REFER WORKPACK
			NG / N1	NF / N2	SHEET:	2 OF 13

Reason for raising: AIRWORTHINESS CHECK PERFORM I.A.W AIRCRAFT MAINTENANCE PROGRAM RMPAOF/CAMO/AMP/AW139 ISSUE 3 REV. 0 DATED 03 FEB 2021 OR LATER APPROVED REVISIONS. DUE AT: <b>NOVEMBER 2023</b>	Raised by and date: CAMO; Hanis 20/10/2023	Other requirements/information: PLEASE NOTE "NIL FLYING" ON THE DATE AIRCRAFT NOT FLYING AND NOT CARRIED OUT.
--	--	--

NO.	ITEM	INSPECTION REQUIREMENT	REMARKS:
1	MAIN AND TAIL ROTOR TIE DOWNS (IF PRESENT)	REMOVED	PF, AC
<b>AREA 1 - HELICOPTER NOSE</b>			
2	NOSE EXTERIOR	CONDITION.	PF, AC
3	PITOT-STATIC PROBE (LEFT SIDE)	COVER REMOVED: CONDITION AND UN-OBSTRUCTED.	PF, AC
4	LEFT SIDE BRAKE LINES IN BRAKE PEDAL AREA (LOOKING THROUGH BOTTOM TRANSPARENT PANEL)	CONDITION.	PF, AC
5	NOSE LANDING GEAR	CONDITION, SHOCK STRUT EXTENSION, LEAKS, TIRE PRESSURE (DI ONLY).	PF, AC
6	VENTILATION AIR INTAKES (IN LANDING GEAR BAY)	UN-OBSTRUCTED.	PF, AC
7	NOSE COMPARTMENT ACCESS DOOR	LATCHED AND SECURED.	PF, AC
8	PITOT-STATIC PROBE (RIGHT SIDE)	COVER REMOVED, CONDITION AND UN-OBSTRUCTED.	PF, AC
9	RIGHT SIDE BRAKE LINES IN BRAKE PEDAL AREA (LOOKING THROUGH BOTTOM TRANSPARENT PANEL)	CONDITION.	PF, AC
<b>AREA 2 - FUSELAGE (RIGHT HAND SIDE)</b>			
10	WINDSHIELD AND ROOF TRANSPARENT PANEL	CONDITION, CLEANLINESS.	PF, AC
11	WINDSCREEN WIPER	CONDITION.	BFF, AC
12	FUSELAGE EXTERIOR	CONDITION.	PF, AC
13.	PILOT COCKPIT DOOR	CONDITION, CLEANLINESS, WINDOW SECURE.	PF, AC
14	PASSENGER CABIN DOOR	CONDITION, CLEANLINESS, SECURE.	PF, AC
15	RIGHT SIDE EMERGENCY EXIT	VERIFY SECURE.	BFF, AC
16	MAIN LANDING GEAR	CONDITION, SHOCK STRUT EXTENSION, LEAKS, TIRE PRESSURE.	PF, AC
17	DRAINS AND VENT LINES	FREE OF OBSTRUCTION.	BFF, AC
18	FUEL TANK SUMP AREA (RIGHT SIDE)	CONFIRM NO LEAKS.	PF, AC
19	BAGGAGE COMPARTMENT, TIE DOWN/NET	CONDITION, CARGO (IF ON BOARD) CORRECTLY SECURED.	PF, AC

\*Certifies that the work specified above, except as otherwise specified, was carried out in accordance with CAA Malaysia Requirements and in respect to that work the aircraft / aircraft component is considered ready for release to service. **AMQ/2016/02**

\*Certifies that the work specified above, except as otherwise specified, was carried out in accordance with \_\_\_\_\_ and in respect to that work the aircraft / aircraft component is considered ready for release to service.

TICK  WHERE APPLICABLE

DATE	BY	CHECKED	DATE	TYPE	REVISION	REASON	DATE	BY	DATE	BY	DATE	BY	DATE	BY	DATE	BY	DATE	BY
------	----	---------	------	------	----------	--------	------	----	------	----	------	----	------	----	------	----	------	----



CLIENT/OWNER: ROYAL MALAYSIA POLICE AIRCRAFT TYPE: AW139 REGISTRATION: 9M-PMD BASE/FACILITY: WMSA DATE IN: REFER WORKPACK OUT: REFER WORKPACK	SERIAL NO.	HOURS	LDG/CYCLE	WORKSHEET NO:	17379-001	
	AIRCRAFT	31809	REFER WORKPACK		WORK/INSP/DESC:	AIRWORTHINESS CHECK
	#1 ENGINE:	PCE-KB2112	REFER WORKPACK		WORKPACK REF:	9M-PMD-17379
	#2 ENGINE:	PCE-KB2092	REFER WORKPACK		AJL REF NO.:	REFER WORKPACK
			NG / N1	NF / N2	SHEET:	3 OF 13

Reason for raising: AIRWORTHINESS CHECK PERFORM I.A.W AIRCRAFT MAINTENANCE PROGRAM RMPAOF/CAMO/AMP/AW139 ISSUE 3 REV. 0 DATED 03 FEB 2021 OR LATER APPROVED REVISIONS. DUE AT: <b>NOVEMBER 2023</b>	Raised by and date: CAMO; Hanis 20/10/2023	Other requirements/information: PLEASE NOTE "NIL FLYING" ON THE DATE AIRCRAFT NOT FLYING AND NOT CARRIED OUT.
--	--	--

NO.	ITEM	INSPECTION REQUIREMENT	REMARKS:
20	BAGGAGE DOOR	SECURE.	PF, AC
21	ENGINE AREA	CHECK FOR FUEL AND/OR OIL LEAKS.	PF, AC
22	COWLING AND FAIRINGS	CONDITION AND LATCHED.	BFF, AC
23	AIR INTAKES	CLEAR AND UNOBSTRUCTED.	BFF, AC
24	MAIN ROTOR COMPONENTS AND BLADES	GENERAL CONDITION.	PF, AC
25	MAIN ROTOR DAMPER INDICATORS	POSITION.	PF, AC
26	ENGINE AIR INTAKE SCREEN	COVER REMOVED (IF INSTALL), FREE OF DAMAGE AND OBSTRUCTION.	BFF, AC
27	ENGINE COWLING	SECURE.	PF, AC
28	GRAVITY FUEL FILLER CAP	SECURE.	PF, AC
29	ENGINE EXHAUST	COVER REMOVED (PF ONLY), CONDITION.	BFF, AC
30	FIRE BOTTLE DISCHARGE INDICATOR	GREEN.	PF, AC
AREA 3 – TAIL BOOM (RIGHT HAND SIDE)			
31	TAIL BOOM EXTERIOR	CONDITION.	PF, AC
32	TAIL ROTOR DRIVE SHAFT COVER	SECURE.	PF, AC
33	ANTENNA (1)	CONDITION.	BFF, AC
34	STABILIZER	CONDITION AND SECURE.	PF, AC
35	NAVIGATION LIGHT	CONDITION	BFF, AC
AREA 4 – FIN, INTERMEDIATE AND TAIL GEARBOX, TAIL ROTOR			

\*Certifies that the work specified above, except as otherwise specified, was carried out in accordance with CAA Malaysia Requirements and in respect to that work the aircraft / aircraft component is considered ready for release to service. **AMO/2016/02**

\*Certifies that the work specified above, except as otherwise specified, was carried out in accordance with \_\_\_\_\_ and in respect to that work the aircraft / aircraft component is considered ready for release to service.

TICK ✓ WHERE APPLICABLE

TEST	ENG	SECUR	GRV	TOP	ADJ	MAINT	FLY	DAY	REP	BY	DATE	ISSUE	PROJ	ENG	REP	DATE
...	...	...	...	...	...	...	...	...	...	...	...	...	...	...	...	...



CLIENT/OWNER: ROYAL MALAYSIA POLICE AIRCRAFT TYPE: AW139 REGISTRATION: 9M-PMD BASE/FACILITY: WMSA DATE IN: REFER WORKPACK OUT: REFER WORKPACK	SERIAL NO.	HOURS	LDG/CYCLE	WORKSHEET NO:	17379-001		
	AIRCRAFT	31809	REFER WORKPACK		WORK/INSP/DESC:	AIRWORTHINESS CHECK	
	#1 ENGINE:	PCE-KB2112	REFER WORKPACK		WORKPACK REF:	9M-PMD-17379	
	#2 ENGINE:	PCE-KB2092	REFER WORKPACK		AJL REF NO.:	REFER WORKPACK	
				NG / N1	NF / N2	SHEET:	4 OF 13

Reason for raising: AIRWORTHINESS CHECK PERFORM I.A.W AIRCRAFT MAINTENANCE PROGRAM RMPAOF/CAMO/AMP/AW139 ISSUE 3 REV. 0 DATED 03 FEB 2021 OR LATER APPROVED REVISIONS. DUE AT: <b>NOVEMBER 2023</b>	Raised by and date: CAMO; Hanis 20/10/2023	Other requirements/information: PLEASE NOTE "NIL FLYING" ON THE DATE AIRCRAFT NOT FLYING AND NOT CARRIED OUT.
--	--	--

NO.	ITEM	INSPECTION REQUIREMENT	REMARKS:
36	TAIL FIN	CONDITION.	BFF, AC
37	INTERMEDIATE AND TAIL ROTOR GEARBOX	CHECK FOR LEAKS.	PF, AC
38	TAIL NAVIGATION AND ANTI-COLLISION LIGHTS	CONDITION.	PF, AC
39	TAIL ROTOR HUB AND BLADES	CONDITION, CLEANLINESS.	PF, AC
40	TAIL ROTOR PITCH CHANGE MECHANISM	CONDITION.	BFF, AC

AREA 5 – TAIL BOOM LEFT HAND SIDE

41	TAIL BOOM EXTERIOR	CONDITION.	PF, AC
42	STABILIZER	CONDITION AND SECURE	PF, AC
43	NAVIGATION LIGHT	CONDITION.	BFF, AC
44	ANTENNA (1)	CONDITION.	BFF, AC
45	TAIL ROTOR DRIVE SHAFT COVER	SECURE.	PF, AC

AREA 6 – FUSELAGE LEFT HAND SIDE

46	FUSELAGE EXTERIOR	CONDITION.	PF, AC
47	ENGINE EXHAUST	COVER REMOVED, CONDITION.	PF, AC
48	FIRE BOTTLE DISCHARGE INDICATOR	GREEN.	PF, AC
49	BAGGAGE COMPARTMENT, TIE DOWN/NET.	CONDITION, CARGO (IF ON BOARD) CORRECTLY SECURE.	PF, AC
50	BAGGAGE DOOR	SECURE.	PF, AC
51	ENGINE AREA	CHECK FOR FUEL AND/OR OIL LEAKS.	PF, AC
52	ENGINE AIR INTAKE SCREEN	COVER REMOVED (IF INSTALL), CLEAR OF DAMAGE AND OBSTRUCTIONS.	BFF, AC

\*Certifies that the work specified above, except as otherwise specified, was carried out in accordance with CAA Malaysia Requirements and in respect to that work the aircraft / aircraft component is considered ready for release to service. **AMO2016/02**

\*Certifies that the work specified above, except as otherwise specified, was carried out in accordance with \_\_\_\_\_ and in respect to that work the aircraft / aircraft component is considered ready for release to service.

TICK  WHERE APPLICABLE

DATE	BY	CHECKED	APPROVED	WORK	TYPICAL	ADDITIONAL	MANUFACTURE	FLIGHT	DATE	STATUS	BY	APPROVED	REMARKS	WORKSHEET	LOG	REVISION	APPROVED



CLIENT/OWNER: ROYAL MALAYSIA POLICE AIRCRAFT TYPE: AW139 REGISTRATION: 9M-PMD BASE/FACILITY: WMSA DATE IN: REFER WORKPACK OUT: REFER WORKPACK	SERIAL NO.	HOURS	LDG/CYCLE	WORKSHEET NO:	17379-001		
	AIRCRAFT	31809	REFER WORKPACK		WORK/INSP/DESC:	AIRWORTHINESS CHECK	
	#1 ENGINE:	PCE-KB2112	REFER WORKPACK		WORKPACK REF:	9M-PMD-17379	
	#2 ENGINE:	PCE-KB2092	REFER WORKPACK		AJL REF NO.:	REFER WORKPACK	
				NG / N1	NF / N2	SHEET:	5 OF 13

Reason for raising: AIRWORTHINESS CHECK PERFORM I.A.W AIRCRAFT MAINTENANCE PROGRAM RMPAOF/CAMO/AMP/AW139 ISSUE 3 REV. 0 DATED 03 FEB 2021 OR LATER APPROVED REVISIONS. DUE AT: <b>NOVEMBER 2023</b>	Raised by and date: CAMO; Hanis 20/10/2023	Other requirements/information: PLEASE NOTE "NIL FLYING" ON THE DATE AIRCRAFT NOT FLYING AND NOT CARRIED OUT.
--	--	--

NO.	ITEM	INSPECTION REQUIREMENT	REMARKS:
53	ENGINE COWLING	SECURE.	PF, AC
54	AIR INTAKES	CLEAN AND UNOBSTRUCTED.	BFF, AC
55	MAIN ROTOR COMPONENTS AND BLADES	GENERAL CONDITION.	PF, AC
56	LEFT SIDE EMERGENCY EXITS	CONFIRM SECURE.	BFF, AC
57	DRAIN AND VENT LINES	FREE OF OBSTRUCTION.	BFF, AC
58	FUEL TANK SUMP AREA (LEFT SIDE)	CONFIRM NO LEAKS.	PF, AC
59	MAIN LANDING GEAR	CONDITION, SHOCK STRUT EXTENSION, LEAKS, TIRE PRESSURE.	PF, AC
60	PASSENGER CABIN DOOR	SECURE.	PF, AC
61	COWLING AND FAIRINGS	CONDITION.	BFF, AC
62	CO-PILOT COCKPIT DOOR	CONDITION, CLEANLINESS, WINDOW SECURE.	PF, AC
63	WINDSHIELD AND ROOF TRANSPARENT PANEL	CONDITION, CLEANLINESS.	PF, AC
64	WINDSCREEN WIPER	CONDITION.	BFF, AC
AREA 7 – CABIN AND COCKPIT INTERIOR			
65	PASSENGER EMERGENCY EXITS	VERIFY SECURE.	PF, AC
66	CABIN INTERIOR	EQUIPMENT AND CARGO SECURE.	PF, AC
67	FIRST AID KIT	ON BOARD.	BFF, AC
68	CABIN FIRE EXTINGUISHER	SECURE, CHARGE.	BFF, AC
69	PASSENGER DOORS	SECURE	PF, AC

\*Certifies that the work specified above, except as otherwise specified, was carried out in accordance with CAA Malaysia Requirements and in respect to that work the aircraft / aircraft component is considered ready for release to service. **AMO/2016/02**

\*Certifies that the work specified above, except as otherwise specified, was carried out in accordance with \_\_\_\_\_ and in respect to that work the aircraft / aircraft component is considered ready for release to service.

TICK  WHERE APPLICABLE

TEST	DO	CHECK	DATE	TIME	BY	REVISION	APPROVED	REVISION	DATE	TIME	BY	REVISION	APPROVED	REVISION	DATE	TIME	BY	REVISION	APPROVED
------	----	-------	------	------	----	----------	----------	----------	------	------	----	----------	----------	----------	------	------	----	----------	----------





CLIENT/OWNER: ROYAL MALAYSIA POLICE AIRCRAFT TYPE: AW139 REGISTRATION: 9M-PMD BASE/FACILITY: WMSA DATE IN: REFER WORKPACK OUT: REFER WORKPACK	SERIAL NO.	HOURS	LDG/CYCLE	WORKSHEET NO:	17379-001		
	AIRCRAFT	31809	REFER WORKPACK		WORK/INSP/DESC:	AIRWORTHINESS CHECK	
	#1 ENGINE:	PCE-KB2112	REFER WORKPACK		WORKPACK REF:	9M-PMD-17379	
	#2 ENGINE:	PCE-KB2092	REFER WORKPACK		AJL REF NO.:	REFER WORKPACK	
				NG / N1	NF / N2	SHEET:	6 OF 13

Reason for raising: AIRWORTHINESS CHECK PERFORM I.A.W AIRCRAFT MAINTENANCE PROGRAM RMPAOF/CAMO/AMP/AW139 ISSUE 3 REV. 0 DATED 03 FEB 2021 OR LATER APPROVED REVISIONS. DUE AT: <b>NOVEMBER 2023</b>	Raised by and date: CAMO; Hanis 20/10/2023	Other requirements/information: PLEASE NOTE "NIL FLYING" ON THE DATE AIRCRAFT NOT FLYING AND NOT CARRIED OUT.
--	--	--

NO.	ITEM	INSPECTION REQUIREMENT	REMARKS:
70	PILOT AND CO-PILOT SAFETY BELT AND INERTIA REEL	CONDITION.	PF, AC
71	PILOT AND CO-PILOT SEAT	SECURE	PF, AC
72	PILOT AND CO-PILOT FLIGHT CONTROL	CONDITION AND SECURE.	BFF, AC
73	LOWER AND LATERAL TRANSPARENT PANEL	INTEGRITY, CLEANLINES AND NO SIGN OF BRAKE FLUID.	PF, AC
74	PILOT AND CO-PILOT DOOR	SECURE.	PF, AC
75	INSTRUMENTS, PANELS AND CIRCUIT BREAKERS.	CONDITION AND LEGIBILITY.	PF, AC
COCKPIT/ENGINE PRE-START CHECKS			
76	PEDALS AND SEATS	ADJUST.	PF, AC
77	SEAT BELT	FASTEN AND ADJUST.	PF, AC
78	CIRCUIT BREAKERS	ALL ENGAGED.	PF, AC
79	ECL'S	CONFIRM AT FLIGHT.	PF, AC
80	ALL SWITCHES	OFF OR CLOSED.	PF, AC
81	ENG 1 AND ENG 2 MODE SWITCHES	OFF.	PF, AC
82	ELT SWITCH ON INSTRUMENT PANEL	CONFIRM ARM	PF, AC
83	LDG GEAR LEVER	CONFIRM DOWN.	PF, AC
84	EXTERNAL POWER UNIT (IF USED)	CONNECT AND SWITCH ON.	PF, AC
85	GROUND SUPPORT PERSONNEL	CONNECTED (IF REQUIRED).	PF, AC
86	BATTERY MASTER	ON. (NOTE: IF EXTERNAL POWER NOT AVAILABLE CARRY OUT CHECKS MARKED WITH * ON BATTERY TO CONSERVE BATTERY POWER. THE REMAINING CHECKS SHOULD BE COMPLETED AFTER THE FIRST ENGINE START)	PF, AC

\*Certifies that the work specified above, except as otherwise specified, was carried out in accordance with CAA Malaysia Requirements and in respect to that work the aircraft / aircraft component is considered ready for release to service. **AMQ/2016/02**

\*Certifies that the work specified above, except as otherwise specified, was carried out in accordance with \_\_\_\_\_ and in respect to that work the aircraft / aircraft component is considered ready for release to service.

TICK ✓ WHERE APPLICABLE

TEST RESULTS	NO. OF DEF	DATE DATE	RECORD NO.	ISSUE	ISSUE NO.	APPROVAL	APPROVAL	APPROVAL	APPROVAL	APPROVAL	APPROVAL	APPROVAL	APPROVAL	APPROVAL	APPROVAL	APPROVAL	APPROVAL	APPROVAL
--------------	------------	-----------	------------	-------	-----------	----------	----------	----------	----------	----------	----------	----------	----------	----------	----------	----------	----------	----------



CLIENT/OWNER: ROYAL MALAYSIA POLICE AIRCRAFT TYPE: AW139 REGISTRATION: 9M-PMD BASE/FACILITY: WMSA DATE IN: REFER WORKPACK OUT: REFER WORKPACK	SERIAL NO.	HOURS	LDG/CYCLE	WORKSHEET NO:	17379-001	
	AIRCRAFT	31809	REFER WORKPACK		WORK/INSP/DESC:	AIRWORTHINESS CHECK
	#1 ENGINE:	PCE-KB2112	REFER WORKPACK		WORKPACK REF:	9M-PMD-17379
	#2 ENGINE:	PCE-KB2092	REFER WORKPACK		AJL REF NO.:	REFER WORKPACK
				NG / N1	NF / N2	
Reason for raising: AIRWORTHINESS CHECK PERFORM I.A.W AIRCRAFT MAINTENANCE PROGRAM RMPAOF/CAMO/AMP/AW139 ISSUE 3 REV. 0 DATED 03 FEB 2021 OR LATER APPROVED REVISIONS. DUE AT: NOVEMBER 2023				Raised by and date: CAMO; Hanis 20/10/2023		
				Other requirements/information: PLEASE NOTE "NIL FLYING" ON THE DATE AIRCRAFT NOT FLYING AND NOT CARRIED OUT.		

NO.	ITEM	INSPECTION REQUIREMENT	REMARKS:
87	BATTERY MAIN AND AUX	ON.	PF, AC
88	EXT PWR	ON (IF REQUIRED).	PF, AC
89	GEN 1 & 2	ON.	PF, AC
90	BUS TIE	AUTO.	PF, AC
91	POSITION LIGHTS SWITCH	CONFIRM FUNCTIONING THEN LEAVE AS REQUIRED.	PF, AC
92	ANTI-COLL LIGHTS SWITCH	ON. (CONFIRM FUNCTIONING) THEN TURN OFF.	PF, AC
93	LT PANEL SWITCH	- ON. CONFIRM EMERGENCY LIGHTS FUNCTIONING CABIN (2), SPONSON (LEFT AND RIGHT), COCKPIT DOOR (LEFT AND RIGHT). -OFF OR ARM, AS REQUIRED.	PF, AC
94	MFD	SET SYSTEM PAGE, SELECT SYS CONFIG AND VERIFY TOP LEVEL SYSTEM PART NUMBER (EPIC SOFTWARE RELEASE) INSTALLED: EB 7030191-00105 PHASE 4 OR EB 7030191-00107 PHASE 5 OR EB 7030191-00108 PHASE 6 OR EB 7030191-00109 PHASE 6 OR EB 7030191-00110 PHASE 7 OR EB 7030191-00111 PHASE 7 OR EB 7030191-00112 PHASE 7 OR EB 7030191-00114 PHASE 7 OR EB 7030191-00115 PHASE 7 OR EB 7030191-00117 PHASE 7 OR EB 7030191-00118 PHASE 7 OR EB 7030191-00113 PHASE 8	PF, AC
95	MFD	SET POWERPLANT PAGE AND CHECK CONFIGURATION SETTING. (NOTE: IF MFD/PFD ARE IN COMPOSITE MODE, RESET TO NORMAL BEFORE STARTING USING RCP SWITCHES (MFD ONLY- PFD ONLY-NORMAL).	PF, AC
96	CAS MESSAGES	CHECK.	PF, AC
97	MFD	CHECK FUEL QUANTITY.	PF, AC
98	LDG GEAR PANEL	CHECK 3 GREEN LIGHTS AND EMER DOWN SWITCH SECURE.	PF, AC
99	NOSE WHEEL LOCK	CONFIRM LOCK ILLUMINATED AND/ OR AIRCRAFT SUITABLY CHOCKED.	PF, AC
100	PARK BRAKE	PULL AND TURN HANDLE AND PRESS PEDALS UNTIL PARK BRAKE ON ADVISORY ILLUMINATES ON CAS.	PF, AC
101	RAD MSTR SWITCH	AS REQUIRED (GND IF BATTERY START).	PF, AC

\*Certifies that the work specified above, except as otherwise specified, was carried out in accordance with CAA Malaysia Requirements and in respect to that work the aircraft / aircraft component is considered ready for release to service. **AMO/2016/02**

\*Certifies that the work specified above, except as otherwise specified, was carried out in accordance with \_\_\_\_\_ and in respect to that work the aircraft / aircraft component is considered ready for release to service.

TICK ✓ WHERE APPLICABLE

TEST	DO	APPROVE	AWARD	ISSUE	ISSUE	ISSUE	ISSUE	ISSUE	ISSUE	ISSUE	ISSUE	ISSUE	ISSUE	ISSUE	ISSUE	ISSUE	ISSUE	ISSUE
------	----	---------	-------	-------	-------	-------	-------	-------	-------	-------	-------	-------	-------	-------	-------	-------	-------	-------



CLIENT/OWNER: ROYAL MALAYSIA POLICE AIRCRAFT TYPE: AW139 REGISTRATION: 9M-PMD BASE/FACILITY: WMSA DATE IN: REFER WORKPACK OUT: REFER WORKPACK	SERIAL NO.	HOURS	LDG/CYCLE	WORKSHEET NO:	17379-001		
	AIRCRAFT	31809	REFER WORKPACK		WORK/INSP/DESC:	AIRWORTHINESS CHECK	
	#1 ENGINE:	PCE-KB2112	REFER WORKPACK		WORKPACK REF:	9M-PMD-17379	
	#2 ENGINE:	PCE-KB2092	REFER WORKPACK		AJL REF NO.:	REFER WORKPACK	
				NG / N1	NF / N2	SHEET:	8 OF 13

Reason for raising: AIRWORTHINESS CHECK PERFORM I.A.W AIRCRAFT MAINTENANCE PROGRAM RMPAOF/CAMO/AMP/AW139 ISSUE 3 REV. 0 DATED 03 FEB 2021 OR LATER APPROVED REVISIONS. DUE AT: <b>NOVEMBER 2023</b>	Raised by and date: CAMO; Hanis 20/10/2023	Other requirements/information: PLEASE NOTE "NIL FLYING" ON THE DATE AIRCRAFT NOT FLYING AND NOT CARRIED OUT.
--	--	--

NO.	ITEM	INSPECTION REQUIREMENT	REMARKS:
100	PARK BRAKE	PULL AND TURN HANDLE AND PRESS PEDALS UNTIL PARK BRAKE ON ADVISORY ILLUMINATES ON CAS.	PF, AC
101	RAD MSTR SWITCH	AS REQUIRED (GND IF BATTERY START).	PF, AC
102	FORCE TRIM SWITCH	ON.	PF, AC
103	CLTV/YAW TRIM SWITCH	ON.	PF, AC
104	AWG SWITCH	AS REQUIRED (REGRADE OR INHIBIT POSITION DISABLES "150 FEET" VOICE MESSAGE).	PF, AC
105	LD-SH SWITCH	TORQUE.	PF, AC
106	AFCS	CONFIRM NOT ENGAGED.	PF, AC
107	CYCLIC STICK	CENTRED.	PF, AC
108	COLLECTIVE LEVER	FULL DOWN, FRICTION AS REQUIRED.	PF, AC
109	FLIGHT CONTROLS	PUSH ELEC PUMP ON HYD PANEL. CARRY OUT CYCLIC, COLLECTIVE AND YAW PEDALS FULL AND FREE CHECK. UTILIZING THE CYCLIC POSITION INDICATOR, ON PFD, CENTRALIZE CYCLIC CONTROL BY MOVING IN THE DIRECTION INDICATED BY THE YELLOW ARROWS TO OBTAIN THE CENTRAL CIRCLE GREEN. ELEC HYD PUMP SELECT OFF. (NOTE: CYCLIC POSITION INDICATOR IS ONLY PRESENTED ON THE PFD WHEN THE AIRCRAFT IS ON THE GROUND AND THE COLLECTIVE IS NEAR ITS DOWN POSITION (MPOG). ELECTRIC HYDRAULIC PUMP DISENGAGES AUTOMATICALLY AFTER 2 MINUTES.)	BFF, AC
110	HYD SOV SWITCH	CENTRED AND GUARDED.	PF, AC
111	FIRE WARNING TEST PUSH BUTTON	PRESS, ON THE TEST CONTROL PANEL, BAG AND CONFIRM THE FOLLOWING VISUAL WARNINGS: - MWL ILLUMINATE - 'BAG FIRE' CAS WARNING - 'BAG' ON FIRE EXTING PANEL - AUDIO TONE AND VOICE WARNING ("WARNING WARNING")	PF, AC

\*Certifies that the work specified above, except as otherwise specified, was carried out in accordance with CAA Malaysia Requirements and in respect to that work the aircraft / aircraft component is considered ready for release to service. **MO/2018/02**

\*Certifies that the work specified above, except as otherwise specified, was carried out in accordance with \_\_\_\_\_ and in respect to that work the aircraft / aircraft component is considered ready for release to service.

TICK ✓ WHERE APPLICABLE

TEST	NO	DATE	TIME	TYPE	REASON	APPROVED	REMARKS	DATE	TIME	TYPE	REASON	APPROVED	REMARKS	DATE	TIME	TYPE	REASON	APPROVED	REMARKS
------	----	------	------	------	--------	----------	---------	------	------	------	--------	----------	---------	------	------	------	--------	----------	---------



CLIENT/OWNER: ROYAL MALAYSIA POLICE AIRCRAFT TYPE: AW139 REGISTRATION: 9M-PMD BASE/FACILITY: WMSA DATE IN: REFER WORKPACK OUT: REFER WORKPACK	SERIAL NO.	HOURS	LDG/CYCLE	WORKSHEET NO:	17379-001		
	AIRCRAFT	31809	REFER WORKPACK		WORK/INSP/DESC:	AIRWORTHINESS CHECK	
	#1 ENGINE:	PCE-KB2112	REFER WORKPACK		WORKPACK REF:	9M-PMD-17379	
	#2 ENGINE:	PCE-KB2092	REFER WORKPACK		AJL REF NO.:	REFER WORKPACK	
				NG / N1	NF / N2	SHEET:	9 OF 13

Reason for raising: AIRWORTHINESS CHECK PERFORM I.A.W AIRCRAFT MAINTENANCE PROGRAM RMPAOF/CAMO/AMP/AW139 ISSUE 3 REV. 0 DATED 03 FEB 2021 OR LATER APPROVED REVISIONS. DUE AT: <b>NOVEMBER 2023</b>	Raised by and date: CAMO; Hanis 20/10/2023	Other requirements/information: PLEASE NOTE "NIL FLYING" ON THE DATE AIRCRAFT NOT FLYING AND NOT CARRIED OUT.
--	--	--

NO.	ITEM	INSPECTION REQUIREMENT	REMARKS:
111	FIRE WARNING TEST PUSH BUTTON	PRESS ENG1, CONFIRM THE FOLLOWING VISUAL AND AUDIO WARNINGS: - ENG 1 ECL FIRE LIGHT - ENG 1 FIRE ON FIRE EXTING PANEL - MWL AND MCL ILLUMINATE - '1 ENG FIRE', CAS WARNING - '1 FIRE DET', CAS CAUTION - AUDIO TONE AND VOICE WARNING ("ENGINE 1 FIRE") - FIRE 1 ON ENG CONTROL PANEL  PRESS, ENG2, CONFIRM THE FOLLOWING VISUAL AND AUDIO WARNINGS: - ENG 2 ECL FIRE LIGHT - ENG 2 FIRE ON FIRE EXTING PANEL - MWL AND MCL ILLUMINATE - '2 ENG FIRE', CAS WARNING - '2 FIRE DET', CAS CAUTION - AUDIO TONE AND VOICE WARNING ("ENGINE 2 FIRE") - FIRE ON 2 ENG CONTROL PANEL	PF, AC
112	FUEL PUSHBUTTON	FUEL TEST STARTS AUTOMATICALLY AT ELECTRICAL POWER ON. CONFIRM 1(2) FCU TEST FAIL CAUTION NOT ILLUMINATED. IF FURTHER TEST REQUIRED PRESS PUSHBUTTON AND CONFIRM THE FOLLOWING: - 'TEST' REPLACES 'FUEL' LEGEND ON PILOT AND COPILOT MFD 1(2) FCU TEST FAIL CAUTION NOT ILLUMINATED.	PF, AC
113	CHIP DETECTOR PUSHBUTTON	PRESS ENG 1 PUSHBUTTON AND CONFIRM CAS CAUTION: 1 ENG CHIP AND MCL ILLUMINATES.  PRESS ENG 2 PUSHBUTTON AND CONFIRM CAS CAUTION: 2 ENG CHIP AND MCL ILLUMINATES.	PF, AC
114	AWG TEST PUSHBUTTON	PRESS, MOMENTARILY, ON THE TEST CONTROL PANEL, AWG. CONFIRM THE AURAL SYSTEM TEST MESSAGE IS HEARD. IF REQUIRED PRESS AND HOLD PUSHBUTTON FOR 6 SECONDS AND CONFIRM THE FOLLOWING AURAL WARNINGS:  AUDIO TONE AND VOICE WARNING ("WARNING") ROTOR LOW ENGINE 1 OUT ENGINE 2 OUT ENGINE 1 FIRE ENGINE 2 FIRE ROTOR HIGH ENGINE 1 IDLE ENGINE 2 IDLE WARNING AUTOPILOT AIRSPEED ALTITUDE LANDING GEAR 150 FEET AURAL SYSTEM TEST	PF, AC
115	OIL LEVEL PUSHBUTTON	PRESS MGB PUSHBUTTON AND CONFIRM CAS CAUTION: MGB OIL LOW AND MCL ILLUMINATES. PRESS IGB PUSHBUTTON AND CONFIRM CAS CAUTION: IGB OIL LOW AND MCL ILLUMINATES.  PRESS TGB PUSHBUTTON AND CONFIRM CAS CAUTION: TGB OIL LOW AND MCL ILLUMINATES.	PF, AC

\*Certifies that the work specified above, except as otherwise specified, was carried out in accordance with CAA Malaysia Requirements and in respect to that work the aircraft / aircraft component is considered ready for release to service. **AMO/2018/02**

\*Certifies that the work specified above, except as otherwise specified, was carried out in accordance with \_\_\_\_\_ and in respect to that work the aircraft / aircraft component is considered ready for release to service.

TICK  WHERE APPLICABLE

TEST	DO	QUALITE	SM	QUAL	TYPE	ADDITIONAL	MANUFACT	FLIGHT	ENG	TYPE	DO	REPART	QUALITY	PROCES	ENG	PERFORM	APPROVE
FILED	FILED	FILED	FILED	FILED	FILED	FILED	FILED	FILED	FILED	FILED	FILED	FILED	FILED	FILED	FILED	FILED	FILED



CLIENT/OWNER: ROYAL MALAYSIA POLICE AIRCRAFT TYPE: AW139 REGISTRATION: 9M-PMD BASE/FACILITY: WMSA DATE IN: REFER WORKPACK OUT: REFER WORKPACK	SERIAL NO.	HOURS	LDG/CYCLE	WORKSHEET NO:	17379-001		
	AIRCRAFT	31809	REFER WORKPACK		WORK/INSP/DESC:	AIRWORTHINESS CHECK	
	#1 ENGINE:	PCE-KB2112	REFER WORKPACK		WORKPACK REF:	9M-PMD-17379	
	#2 ENGINE:	PCE-KB2092	REFER WORKPACK		AJL REF NO.:	REFER WORKPACK	
				NG / N1	NF / N2	SHEET:	10 OF 13

Reason for raising: AIRWORTHINESS CHECK PERFORM I.A.W AIRCRAFT MAINTENANCE PROGRAM RMPAOF/CAMO/AMPI/AW139 ISSUE 3 REV. 0 DATED 03 FEB 2021 OR LATER APPROVED REVISIONS. DUE AT: <b>NOVEMBER 2023</b>	Raised by and date: CAMO; Hanis 20/10/2023	Other requirements/information: PLEASE NOTE "NIL FLYING" ON THE DATE AIRCRAFT NOT FLYING AND NOT CARRIED OUT.
---	--	--

NO.	ITEM	INSPECTION REQUIREMENT	REMARKS:
116	LAMP TEST PUSHBUTTON	PRESS AND CONFIRM THE FOLLOWING ILLUMINATE: -MWL AND MCL ILLUMINATE -ENG 1 & 2 FIRE/ARM AND BAG ON FIR EXTING PANEL -FIRE LIGHTS ON ENG CONTROL PANEL -HYD 1 & 2 PRESS/TEMP & ELEC PUMP ON, ON HYD PANEL - NOSE/LH/RH RED AND GREEN LAMPS, NOSE WHEEL UNLK/LOCK LAMPS ON LDG GEAR PANEL - ALL GREEN INDICATIONS ON THE AUTOPILOT AND GUIDANCE CONTROL PANEL	BFF
117	RPM SWITCH (ON COLLECTIVE)	SET 100%.	PF, AC
118	1 ENG GOV (ON COLLECTIVE)	AUTO.	PF, AC
119	2 ENG GOV (ON COLLECTIVE)	AUTO.	PF, AC
120	ENG TRIM BEEP SWITCHES (ON COLLECTIVE)	VERIFY OPERATION, THEN LEAVE THE ENGINE CONTROL LEVERS IN THE FLIGHT POSITION.  ON BATTERY POWER USE A SINGLE 'CLICK' BACK AND FORWARD TO CONFIRM ECL STOPS IN FLIGHT GATE.  (NOTE: EACH ENGINE TRIM BEEP SWITCH CONTROLS THE RESPECTIVE CONTROL LEVER FROM MIN TO FLIGHT POSITION WHEN IN AUTO MODE, AND FROM MIN TO MAX POSITION WHEN IN MANUAL MODE.  BOTH ENGINES CONTROL LEVERS SHOULD ALWAYS BE OPERATED THROUGH THE BEEP SWITCHES LOCATED ON THE COLLECTIVE CONTROL. THEY SHOULD BE OPERATED MANUALLY ONLY IN CASE OF  FAILURE OF THE REMOTE CONTROL (ECL FAIL CAUTION MESSAGE), OR BEFORE STARTING, TO POSITION THE LEVER TO FLIGHT.  NOSE WHEEL SHOULD BE LOCKED, YAW PEDALS CENTRALIZED AND THE AIRCRAFT SUITABLE CHOCKED TO AVOID POSSIBLE AIRCRAFT MOVEMENT DURING ROTOR START.	PF, AC
MISSION EQUIPMENT			
121	RESCUE HOIST CABLE	DO A GVI OF THE MAXIMUM LENGTH OF CABLE USED DURING THE DAY OPERATION FOR DAMAGE AND CONDITION (AFTER THE LAST FLIGHT OF THE DAY OR BEFORE THE FIRST FLIGHT OF THE DAY IF THE RESCUE HOIST IS USED OR IT IS ENVISAGED TO BE USED).  REF: 39-A-25-96-01-00A-310A-K, AMPI 05-21 TABLE 6 SINGLE RESCUE HOIST SYSTEM (GOODRICH)	PF, AC

\*Certifies that the work specified above, except as otherwise specified, was carried out in accordance with CAA Malaysia Requirements and in respect to that work the aircraft / aircraft component is considered ready for release to service. **AMO/2016/02**

\*Certifies that the work specified above, except as otherwise specified, was carried out in accordance with \_\_\_\_\_ and in respect to that work the aircraft / aircraft component is considered ready for release to service.

TICK ✓ WHERE APPLICABLE

PARTS ASSEMBLY EQUIPMENT	NO FIELD	DATE DATE BY	WORKING TIME	WORKING HOURS	WORKING MINS	REPAIRS COMPLETED	WORKING STATUS	WORKING REASON	WORKING TYPE	WORKING RELEASE	WORKING DATE	WORKING SPEC	WORKING JOB	WORKING JOB	WORKING JOB	WORKING JOB	WORKING JOB	WORKING JOB	WORKING JOB
--------------------------------	-------------	-----------------	-----------------	------------------	-----------------	----------------------	-------------------	-------------------	-----------------	--------------------	-----------------	-----------------	----------------	----------------	----------------	----------------	----------------	----------------	----------------



CLIENT/OWNER: ROYAL MALAYSIA POLICE AIRCRAFT TYPE: AW139 REGISTRATION: 9M-PMD BASE/FACILITY: WMSA DATE IN: REFER WORKPACK OUT: REFER WORKPACK	SERIAL NO.	HOURS	LDG/CYCLE	WORKSHEET NO:	17379-001		
	AIRCRAFT	31809	REFER WORKPACK		WORK/INSP/DESC:	AIRWORTHINESS CHECK	
	#1 ENGINE:	PCE-KB2112	REFER WORKPACK		WORKPACK REF:	9M-PMD-17379	
	#2 ENGINE:	PCE-KB2092	REFER WORKPACK		AJL REF NO.:	REFER WORKPACK	
				NG / N1	NF / N2	SHEET:	11 OF 13

Reason for raising: AIRWORTHINESS CHECK PERFORM I,A,W AIRCRAFT MAINTENANCE PROGRAM RMPAOF/CAMO/AMP/AW139 ISSUE 3 REV. 0 DATED 03 FEB 2021 OR LATER APPROVED REVISIONS. DUE AT: <b>NOVEMBER 2023</b>	Raised by and date: CAMO; Hanis 20/10/2023	Other requirements/information: PLEASE NOTE "NIL FLYING" ON THE DATE AIRCRAFT NOT FLYING AND NOT CARRIED OUT.
--	--	--

NO.	ITEM	INSPECTION REQUIREMENT	REMARKS:
122	RESCUE HOIST OIL LEVEL SIGHT AND ADJACENT AREAS	GENERAL VISUAL INSPECTION TO CHECK FOR CORRECT OIL LEVEL AND LEAK. REF: 39-A-25-96-01-00B-310A-K, AMPI 05-21 TABLE 6 SINGLE RESCUE HOIST SYSTEM (GOODRICH)	PF / PRIOR TO FIRST USE OF THE DAY
123	RESCUE HOIST BOOM	GENERAL VISUAL INSPECTION FOR CONDITION, SECURITY AND DAMAGE OF THE BOOM. TASK INCLUDED ADJACENT FUSELAGE AREA. REF: 39-A-25-96-10-00A-310A-K, AMPI 05-21 TABLE 6 SINGLE RESCUE HOIST SYSTEM (GOODRICH)	PF / PRIOR TO FIRST USE OF THE DAY
124	RESCUE HOIST	ON CONDITION CHECK OF THE HOOK ASSEMBLY BEARING FOR FREEDOM OF ROTATION. REF: 39-A-25-96-00-00A-320B-K, AMPI 05-21 TABLE 6 SINGLE RESCUE HOIST SYSTEM (GOODRICH)	PF, AC
125	RESCUE HOIST	GENERAL VISUAL INSPECTION OF THE HOOK BUMPER ASSEMBLY FOR DAMAGE AND CONDITION. REF: 39-A-25-96-01-00A-310A-K, AMPI 05-21 TABLE 6 SINGLE RESCUE HOIST SYSTEM (GOODRICH)	PF, AC
126	RESCUE HOIST	FOLLOWING USE IN A SALT WATER ENVIRONMENT, WASH THE CABLE AND THE HOOK ASSEMBLY WITH FRESH WATER AND DRY USING A CLEAN, HEAVY DUTY LINT-FREE CLOTH. REF: 39-A-25-96-01-00A-251A-K, AMPI 05-21 TABLE 6 SINGLE RESCUE HOIST SYSTEM (GOODRICH)	AC / AFTER LAST USE OF THE DAY
127	CARGO HOOK	GENERAL & PHYSICAL CONDITION, SECURITY. (IF INSTALLED)	PF, AC
128	SEARCH LIGHT SYSTEM	GENERAL & PHYSICAL CONDITION, SECURITY. (IF INSTALLED)	PF, AC
129	AUX FUEL TANK	GENERAL & PHYSICAL CONDITION, ATTACHMENT, SECURITY. (IF INSTALLED)	PF, AC
130	MISSION CONSOLE	GENERAL & PHYSICAL CONDITION, ATTACHMENT. (IF INSTALLED)	PF, AC
131	FAST ROPING & RAPPELLING SYSTEM	GENERAL & PHYSICAL CONDITION, ATTACHMENT, SECURITY. (IF INSTALLED)	PF, AC

**AIRWORTHINESS CHECKS (AC) ACCOMPLISHMENT INSTRUCTION**

132	JOURNEY LOG SHEET	TO OBSERVE ANY OPEN ENTRY, DEFECT AND DUE DEFERRED DEFECT ARE CLOSED AND RECTIFIED, ALL REQUIRED DETAILS UPDATED.	PF, AC
-----	-------------------	---	--------

\*Certifies that the work specified above, except as otherwise specified, was carried out in accordance with CAA Malaysia Requirements and in respect to that work the aircraft / aircraft component is considered ready for release to service. **MO/2018/02**

\*Certifies that the work specified above, except as otherwise specified, was carried out in accordance with \_\_\_\_\_ and in respect to that work the aircraft / aircraft component is considered ready for release to service.

TICK  WHERE APPLICABLE

ISSUE NO.	ISSUED BY	CHECKED BY	APPROVED BY	DATE	TIME	STATUS	REMARKS	APPROVED BY	DATE	TIME	STATUS	REMARKS	APPROVED BY	DATE	TIME	STATUS	REMARKS
-----------	-----------	------------	-------------	------	------	--------	---------	-------------	------	------	--------	---------	-------------	------	------	--------	---------



CLIENT/OWNER: ROYAL MALAYSIA POLICE AIRCRAFT TYPE: AW139 REGISTRATION: 9M-PMD BASE/FACILITY: WMSA DATE IN: REFER WORKPACK OUT: REFER WORKPACK	SERIAL NO. 31809 AIRCRAFT #1 ENGINE: PCE-KB2112 #2 ENGINE: PCE-KB2092	HOURS REFER WORKPACK REFER WORKPACK REFER WORKPACK	LDG/CYCLE NG / N1 NF / N2	WORKSHEET NO: 17379-001 WORK/INSP/DESC: AIRWORTHINESS CHECK WORKPACK REF: 9M-PMD-17379 AJL REF NO.: REFER WORKPACK SHEET: 12 OF 13
---	--	---	---------------------------------	--

Reason for raising:  
AIRWORTHINESS CHECK PERFORM I.A.W AIRCRAFT MAINTENANCE PROGRAM  
RMPAOF/CAMO/AMP/AW139 ISSUE 3 REV. 0 DATED 03 FEB 2021 OR LATER  
APPROVED REVISIONS. DUE AT: NOVEMBER 2023

Raised by and date:  
CAMO; Hanis  
20/10/2023

Other requirements/information:  
*PLEASE NOTE "NIL FLYING" ON THE DATE AIRCRAFT NOT FLYING AND NOT CARRIED OUT.*

NO.	ITEM	INSPECTION REQUIREMENT	REMARKS:
133	JOURNEY LOG SHEET	TO ENSURE ALL DAILY INSPECTION ITEMS ON ALL AREA/ZONE ARE COMPLETED, ADDITIONAL WORKSHEET (IF ANY) CLOSED AND TO SIGN FOR AIRWORTHINESS CHECKS IN RESPECTIVE COLUMN.	PF, AC

**SUPPLEMENT**

134	INLET BARRIER FILTER SYSTEM	<ul style="list-style-type: none"> <li>ENSURE IBF ENVIRONMENTAL PROTECTIVE COVERS ARE REMOVED, REINSTALLED AFTER VISUAL CHECK.</li> <li>PERFORM A VISUAL CHECK TO VERIFY THAT THE BYPASS DOORS ARE IN THE CLOSED POSITION AND CLEAR FROM ANY OBSTRUCTIONS.</li> <li>CHECK IBF FILTER MAINTENANCE AID TO DETERMINE CONDITION OF THE FILTERS. WHEN INDICATOR ENTERS RED ZONE, IT IS RECOMMENDED THE FILTER BE SERVICED AS PER IBF INSTRUCTION FOR CONTINUED AIRWORTHINESS, AFS-AW139-IBF-ICA</li> </ul>	PF, AC
-----	-----------------------------	---	--------

**MAINTENANCE TASK**

135	NUMBER 1 ENGINE OIL LEVEL INDICATOR	DO A VC OF OIL LEVEL. REPLENISH AS REQUIRED. REF: 39-A-05-21-00-00A-028E-P, AMPI 05-21 TABLE 3 LIST OF REQUIREMENTS FOR SCHEDULED / UNSCHEDULED MAINTENANCE CHECK.& EMM 72-00-00	BFF, NOTE 1, NOTE 2
136	NUMBER 1 ENGINE OIL FILTER POP-OUT INDICATOR	DO A VC. REF: 39-A-05-21-00-00A-028E-P, AMPI 05-21 TABLE 3 LIST OF REQUIREMENTS FOR SCHEDULED / UNSCHEDULED MAINTENANCE CHECK.& EMM 79-20-02	BFF, NOTE 1, NOTE 2
137	NUMBER 2 ENGINE OIL LEVEL INDICATOR	DO A VC OIL LEVEL. REPLENISH AS REQUIRED. REF: 39-A-05-21-00-00A-028E-P, AMPI 05-21 TABLE 3 LIST OF REQUIREMENTS FOR SCHEDULED / UNSCHEDULED MAINTENANCE CHECK.& EMM 72-00-00	BFF, NOTE 1, NOTE 2
138	NUMBER 2 ENGINE OIL FILTER POP-OUT INDICATOR	DO A VC. REF: 39-A-05-21-00-00A-028E-P, AMPI 05-21 TABLE 3 LIST OF REQUIREMENTS FOR SCHEDULED / UNSCHEDULED MAINTENANCE CHECK.& EMM 79-20-02	BFF, NOTE 1, NOTE 2
139	CARGO HOOK ELECTRICAL CABLES	DO A GVI FOR CONDITION AND DAMAGE, INCLUDING CLEANING OF CABLES WITH WATER, THEN DRY WITH A LINT FREE CLOTH. REF: 39-A-25-92-00-00A-310A-K, AMPI 05-21 TABLE 3 LIST OF REQUIREMENTS FOR SCHEDULED /UNSCHEDULED MAINTENANCE CHECK.	AFTER LAST USE OF THE DAY

**DAILY FUEL DRAIN CHECK**

140	FUEL TANK DRAIN CHECK	DRAIN 10 TO 20CC FROM EACH FUEL SUMP WATER DRAIN VALVE BY ACTIVATING THE RELEVANT PUSH BUTTON. RELEASE THE PUSHBUTTON, CONFIRM THAT THE FUEL IS FREE OF WATER AND NO FUEL IS DRIPPING FROM THE AIRCRAFT DRAINS.	BFF, AC
-----	-----------------------	---	---------

\*Certifies that the work specified above, except as otherwise specified, was carried out in accordance with CAA Malaysia Requirements and in respect to that work the aircraft / aircraft component is considered ready for release to service. **AMO/2016/02**

\*Certifies that the work specified above, except as otherwise specified, was carried out in accordance with \_\_\_\_\_ and in respect to that work the aircraft / aircraft component is considered ready for release to service.

TICK ✓ WHERE APPLICABLE

DATE	BY	DATE	BY	DATE	BY	DATE	BY	DATE	BY	DATE	BY	DATE	BY	DATE	BY	DATE	BY	DATE	BY	



CLIENT/OWNER: ROYAL MALAYSIA POLICE AIRCRAFT TYPE: AW139 REGISTRATION: 9M-PMD BASE/FACILITY: WMSA DATE IN: REFER WORKPACK OUT: REFER WORKPACK	SERIAL NO.	HOURS	LDG/CYCLE	WORKSHEET NO:	17379-001	
	AIRCRAFT	31809	REFER WORKPACK	WORK/INSP/DESC:	AIRWORTHINESS CHECK	
	#1 ENGINE:	PCE-KB2112	REFER WORKPACK	WORKPACK REF:	9M-PMD-17379	
	#2 ENGINE:	PCE-KB2092	REFER WORKPACK	AJL REF NO.:	REFER WORKPACK	
			NG / N1	NF / N2	SHEET:	13 OF 13

Reason for raising: AIRWORTHINESS CHECK PERFORM I.A.W AIRCRAFT MAINTENANCE PROGRAM RMPAOF/CAMO/AMP/AW139 ISSUE 3 REV. 0 DATED 03 FEB 2021 OR LATER APPROVED REVISIONS. DUE AT: <b>NOVEMBER 2023</b>	Raised by and date: CAMO; Hanis 20/10/2023	Other requirements/information: PLEASE NOTE "NIL FLYING" ON THE DATE AIRCRAFT NOT FLYING AND NOT CARRIED OUT.
--	--	--

NO.	ITEM	INSPECTION REQUIREMENT	REMARKS:
-----	------	------------------------	----------

NOTES:

- IF A STEP ON REAR FAIRING IS INSTALLED ON MLG SPONSON THE TASK CAN BE PERFORMED BY THE PILOT PRIOR FIRST FLIGHT OF THE DAY. IT IS NOT NECESSARY TO APPLY THIS TASK ONLY IF IT IS PERFORMED BY THE PILOT PRIOR FIRST FLIGHT OF THE DAY.
- TASK TO BE PERFORMED BY FOLLOWING THE INSTRUCTIONS CONTAINED IN THE LAST ISSUE OF P&W PT6C-67C ENGINE MAINTENANCE MANUAL.

\*Certifies that the work specified above, except as otherwise specified, was carried out in accordance with CAA Malaysia Requirements and in respect to that work the aircraft / aircraft component is considered ready for release to service. **AMO/2018/02**

\*Certifies that the work specified above, except as otherwise specified, was carried out in accordance with \_\_\_\_\_ and in respect to that work the aircraft / aircraft component is considered ready for release to service.

TICK ✓ WHERE APPLICABLE

ISSUE	BY	DATE	NO.	TYPE	REASON	APPROVED	DATE	TIME	BY	DATE	TIME	BY	DATE	TIME	BY	DATE	TIME	BY	DATE	TIME
-------	----	------	-----	------	--------	----------	------	------	----	------	------	----	------	------	----	------	------	----	------	------





CLIENT/OWNER: ROYAL MALAYSIA POLICE AIRCRAFT TYPE: AW139 REGISTRATION: 9M-PMD BASE/FACILITY: WMSA DATE IN: REFER WORKPACK OUT: REFER WORKPACK	SERIAL NO. 31809 AIRCRAFT #1 ENGINE: PCE-KB2112 #2 ENGINE: PCE-KB2092	HOURS REFER WORKPACK REFER WORKPACK REFER WORKPACK	LDG/CYCLE NG / N1 NF / N2	WORKSHEET NO: 17379-001 WORK/INSP/DESC: AIRWORTHINESS CHECK WORKPACK REF: 9M-PMD-17379 AJL REF NO.: REFER WORKPACK SHEET: 1 OF 5
---	--	---	---------------------------------	--

Reason for raising:  
AIRWORTHINESS CHECK PERFORM I.A.W AIRCRAFT MAINTENANCE PROGRAM  
RMPAOF/CAMO/AMP/AW139 ISSUE 3 REV. 0 DATED 03 FEB 2021 OR LATER  
APPROVED REVISIONS. DUE AT: **NOVEMBER 2023**

Raised by and date:  
CAMO: Hanis  
20/10/2023

Other requirements/information:  
**PLEASE NOTE "NIL FLYING" ON THE DATE AIRCRAFT NOT FLYING AND NOT CARRIED OUT.**

Item	Description	Technician	* Eng. CRS	Date
1	<b>DATE: 01 NOVEMBER 2023</b> AIRWORTHINESS CHECK TO BE CARRIED OUT NOTE: VALID UNTIL 72 HOURS FROM LAST AIRWORTHINESS CHECK CARRIED OUT IF AIRCRAFT NOT FLOWN. REF: AMP RMPAOF/CAMO/AMP/AW139 ISSUE 3 REV. 0 DATED 03 FEB 2021 AJL NO.: <u>01411</u> AIRCRAFT HOURS: <u>1815:10</u> REMARKS: <b>FOUND SATISFACTORY</b>	<i>[Signature]</i> 8335	<i>[Signature]</i> 	01/11/23
2	<b>DATE: 02 NOVEMBER 2023</b> AIRWORTHINESS CHECK TO BE CARRIED OUT NOTE: VALID UNTIL 72 HOURS FROM LAST AIRWORTHINESS CHECK CARRIED OUT IF AIRCRAFT NOT FLOWN. REF: AMP RMPAOF/CAMO/AMP/AW139 ISSUE 3 REV. 0 DATED 03 FEB 2021 AJL NO.: <u>01412</u> AIRCRAFT HOURS: <u>1819:25</u> REMARKS: <b>FOUND SATISFACTORY</b>	<i>[Signature]</i> 8266	<i>[Signature]</i> 	02/11/23
3	<b>DATE: 03 NOVEMBER 2023</b> AIRWORTHINESS CHECK TO BE CARRIED OUT NOTE: VALID UNTIL 72 HOURS FROM LAST AIRWORTHINESS CHECK CARRIED OUT IF AIRCRAFT NOT FLOWN. REF: AMP RMPAOF/CAMO/AMP/AW139 ISSUE 3 REV. 0 DATED 03 FEB 2021 AJL NO.: <u>01413</u> AIRCRAFT HOURS: <u>1820:25</u> REMARKS: <b>FOUND SATISFACTORY</b>	<i>[Signature]</i> 8101	<i>[Signature]</i> 	3/11/23
4	<b>DATE: 04 NOVEMBER 2023</b> AIRWORTHINESS CHECK TO BE CARRIED OUT NOTE: VALID UNTIL 72 HOURS FROM LAST AIRWORTHINESS CHECK CARRIED OUT IF AIRCRAFT NOT FLOWN. REF: AMP RMPAOF/CAMO/AMP/AW139 ISSUE 3 REV. 0 DATED 03 FEB 2021 AJL NO.: <u>-</u> AIRCRAFT HOURS: <u>-</u> REMARKS: <b>NIL FLIGHT</b>	-	<i>[Signature]</i> 	4/11/23
5	<b>DATE: 05 NOVEMBER 2023</b> AIRWORTHINESS CHECK TO BE CARRIED OUT NOTE: VALID UNTIL 72 HOURS FROM LAST AIRWORTHINESS CHECK CARRIED OUT IF AIRCRAFT NOT FLOWN. REF: AMP RMPAOF/CAMO/AMP/AW139 ISSUE 3 REV. 0 DATED 03 FEB 2021 AJL NO.: <u>-</u> AIRCRAFT HOURS: <u>-</u> REMARKS: <b>NIL FLIGHT</b>	-	<i>[Signature]</i> 	5/11/23
6	<b>DATE: 06 NOVEMBER 2023</b> AIRWORTHINESS CHECK TO BE CARRIED OUT NOTE: VALID UNTIL 72 HOURS FROM LAST AIRWORTHINESS CHECK CARRIED OUT IF AIRCRAFT NOT FLOWN. REF: AMP RMPAOF/CAMO/AMP/AW139 ISSUE 3 REV. 0 DATED 03 FEB 2021 AJL NO.: <u>01415</u> AIRCRAFT HOURS: <u>1821:25</u> REMARKS: <b>CARRIED OUT - FOUND SATISFACTORY</b>	<i>[Signature]</i> 8438	<i>[Signature]</i> 	6/11/23

\*Certifies that the work specified above, except as otherwise specified, was carried out in accordance with CAA Malaysia Requirements and in respect to that work the aircraft / aircraft component is considered ready for release to service. **AMO/2016/02**

\*Certifies that the work specified above, except as otherwise specified, was carried out in accordance with \_\_\_\_\_ and in respect to that work the aircraft / aircraft component is considered ready for release to service.

TICK ✓ WHERE APPLICABLE

REP. ORDER NO.	DO. NO.	DATE	ISSUE NO.	ISSUE DATE	ISSUE TIME	ISSUE BY	ISSUE FOR	ISSUE TO	ISSUE AT	ISSUE BY	ISSUE FOR	ISSUE TO	ISSUE AT	ISSUE BY	ISSUE FOR	ISSUE TO	ISSUE AT
----------------	---------	------	-----------	------------	------------	----------	-----------	----------	----------	----------	-----------	----------	----------	----------	-----------	----------	----------



CLIENT/OWNER: ROYAL MALAYSIA POLICE AIRCRAFT TYPE: AW139 REGISTRATION: 9M-PMD BASE/FACILITY: WMSA DATE IN: REFER WORKPACK OUT: REFER WORKPACK		SERIAL NO. 31809	HOURS	LDG/CYCLE	WORKSHEET NO: 17379-001 WORK/INSP/DESC: AIRWORTHINESS CHECK WORKPACK REF: 9M-PMD-17379 AJL REF NO.: REFER WORKPACK SHEET: 2 OF 5
		AIRCRAFT	REFER WORKPACK		
		#1 ENGINE: PCE-KB2112	REFER WORKPACK		
		#2 ENGINE: PCE-KB2092	REFER WORKPACK		
				NG / N1	NF / N2
Reason for raising: AIRWORTHINESS CHECK PERFORM I.A.W AIRCRAFT MAINTENANCE PROGRAM RMPAOF/CAMO/AMP/AW139 ISSUE 3 REV. 0 DATED 03 FEB 2021 OR LATER APPROVED REVISIONS. DUE AT: NOVEMBER 2023			Raised by and date: CAMO: Hanis 20/10/2023		Other requirements/information: PLEASE NOTE "NIL FLYING" ON THE DATE AIRCRAFT NOT FLYING AND NOT CARRIED OUT.
Item	Description	Technician	* Eng. CRS	Date	
07	<b>DATE: 07 NOVEMBER 2023</b> AIRWORTHINESS CHECK TO BE CARRIED OUT NOTE: VALID UNTIL 72 HOURS FROM LAST AIRWORTHINESS CHECK CARRIED OUT IF AIRCRAFT NOT FLOWN. REF: AMP RMPAOF/CAMO/AMP/AW139 ISSUE 3 REV. 0 DATED 03 FEB 2021 AJL NO.: <u>01416</u> AIRCRAFT HOURS: <u>1823:00</u> REMARKS: <u>CARRY OUT PMD INSPECTION</u>	<i>Handwritten Signature</i> 8159	 <i>Handwritten Signature</i>	07/11/23	
08	<b>DATE: 08 NOVEMBER 2023</b> AIRWORTHINESS CHECK TO BE CARRIED OUT NOTE: VALID UNTIL 72 HOURS FROM LAST AIRWORTHINESS CHECK CARRIED OUT IF AIRCRAFT NOT FLOWN. REF: AMP RMPAOF/CAMO/AMP/AW139 ISSUE 3 REV. 0 DATED 03 FEB 2021 AJL NO.: <u>01417</u> AIRCRAFT HOURS: <u>1824:20</u> REMARKS: <u>FOUND SATISFACTORY</u>	<i>Handwritten Signature</i> 8095	 <i>Handwritten Signature</i>	08/11/23	
09	<b>DATE: 09 NOVEMBER 2023</b> AIRWORTHINESS CHECK TO BE CARRIED OUT NOTE: VALID UNTIL 72 HOURS FROM LAST AIRWORTHINESS CHECK CARRIED OUT IF AIRCRAFT NOT FLOWN. REF: AMP RMPAOF/CAMO/AMP/AW139 ISSUE 3 REV. 0 DATED 03 FEB 2021 AJL NO.: <u>01418</u> AIRCRAFT HOURS: <u>1827:25</u> REMARKS: <u>FOUND SATISFACTORY</u>	<i>Handwritten Signature</i> 8095	 <i>Handwritten Signature</i>	9/11/23	
10	<b>DATE: 10 NOVEMBER 2023</b> AIRWORTHINESS CHECK TO BE CARRIED OUT NOTE: VALID UNTIL 72 HOURS FROM LAST AIRWORTHINESS CHECK CARRIED OUT IF AIRCRAFT NOT FLOWN. REF: AMP RMPAOF/CAMO/AMP/AW139 ISSUE 3 REV. 0 DATED 03 FEB 2021 AJL NO.: <u>01419</u> AIRCRAFT HOURS: <u>1829:30</u> REMARKS:	<i>Handwritten Signature</i> 8337	 <i>Handwritten Signature</i>	10/11/23	
11	<b>DATE: 11 NOVEMBER 2023</b> AIRWORTHINESS CHECK TO BE CARRIED OUT NOTE: VALID UNTIL 72 HOURS FROM LAST AIRWORTHINESS CHECK CARRIED OUT IF AIRCRAFT NOT FLOWN. REF: AMP RMPAOF/CAMO/AMP/AW139 ISSUE 3 REV. 0 DATED 03 FEB 2021 AJL NO.: <u>01420</u> AIRCRAFT HOURS: <u>1830:45</u> REMARKS: <u>CLAM FOUND SATIS.</u>	<i>Handwritten Signature</i> 8438	 <i>Handwritten Signature</i>	11/11/23	
12	<b>DATE: 12 NOVEMBER 2023</b> AIRWORTHINESS CHECK TO BE CARRIED OUT NOTE: VALID UNTIL 72 HOURS FROM LAST AIRWORTHINESS CHECK CARRIED OUT IF AIRCRAFT NOT FLOWN. REF: AMP RMPAOF/CAMO/AMP/AW139 ISSUE 3 REV. 0 DATED 03 FEB 2021 AJL NO.: <u>-</u> AIRCRAFT HOURS: <u>-</u> REMARKS: <u>NIL FLIGHT</u>	-	 <i>Handwritten Signature</i>	12/11/23	
<input checked="" type="checkbox"/> *Certifies that the work specified above, except as otherwise specified, was carried out in accordance with CAA Malaysia Requirements and in respect to that work the aircraft / aircraft component is considered ready for release to service. <b>4MO/2018/02</b> <input type="checkbox"/> *Certifies that the work specified above, except as otherwise specified, was carried out in accordance with _____ and in respect to that work the aircraft / aircraft component is considered ready for release to service.					
<input type="checkbox"/> TICK <input checked="" type="checkbox"/> WHERE APPLICABLE					

ISSUE	REVISED	DATE	BY	REASON	APPROVED	DATE	REASON	APPROVED	DATE	REASON	APPROVED	DATE	REASON	APPROVED	DATE	REASON	APPROVED	DATE	REASON	APPROVED	DATE	REASON
-------	---------	------	----	--------	----------	------	--------	----------	------	--------	----------	------	--------	----------	------	--------	----------	------	--------	----------	------	--------



CLIENT/OWNER: ROYAL MALAYSIA POLICE AW139	SERIAL NO. 31809	HOURS REFER WORKPACK	LDG/CYCLE	WORKSHEET NO: 17379-001
AIRCRAFT TYPE: 9M-PMD	#1 ENGINE: PCE-KB2112	REFER WORKPACK		WORK/INSP/DESC: AIRWORTHINESS CHECK
BASE/FACILITY: WMSA	#2 ENGINE: PCE-KB2092	REFER WORKPACK		WORKPACK REF: 9M-PMD-17379
DATE IN: REFER WORKPACK OUT: REFER WORKPACK			NG / N1 NF / N2	AJL REF NO.: REFER WORKPACK
				SHEET: 3 OF 5

Reason for raising: AIRWORTHINESS CHECK PERFORM I.A.W AIRCRAFT MAINTENANCE PROGRAM RMPAOF/CAMO/AMP/AW139 ISSUE 3 REV. 0 DATED 03 FEB 2021 OR LATER APPROVED REVISIONS. DUE AT: NOVEMBER 2023	Raised by and date: CAMO; Hanis 20/10/2023	Other requirements/information: <i>PLEASE NOTE "NIL FLYING" ON THE DATE AIRCRAFT NOT FLYING AND NOT CARRIED OUT.</i>
---	--	---

Item	Description	Technician	* Eng. CRS	Date
13	<b>DATE: 13 NOVEMBER 2023</b> AIRWORTHINESS CHECK TO BE CARRIED OUT NOTE: VALID UNTIL 72 HOURS FROM LAST AIRWORTHINESS CHECK CARRIED OUT IF AIRCRAFT NOT FLOWN. REF: AMP RMPAOF/CAMO/AMP/AW139 ISSUE 3 REV. 0 DATED 03 FEB 2021 AJL NO.: _____ AIRCRAFT HOURS: : _____ REMARKS: <i>NIL FLIGHT</i>	-	 	<i>13/11/23</i>
14	<b>DATE: 14 NOVEMBER 2023</b> AIRWORTHINESS CHECK TO BE CARRIED OUT NOTE: VALID UNTIL 72 HOURS FROM LAST AIRWORTHINESS CHECK CARRIED OUT IF AIRCRAFT NOT FLOWN. REF: AMP RMPAOF/CAMO/AMP/AW139 ISSUE 3 REV. 0 DATED 03 FEB 2021 AJL NO.: _____ AIRCRAFT HOURS: : _____ REMARKS: <i>NIL FLIGHT</i>	-	 	<i>14/11/2023</i>
15	<b>DATE: 15 NOVEMBER 2023</b> AIRWORTHINESS CHECK TO BE CARRIED OUT NOTE: VALID UNTIL 72 HOURS FROM LAST AIRWORTHINESS CHECK CARRIED OUT IF AIRCRAFT NOT FLOWN. REF: AMP RMPAOF/CAMO/AMP/AW139 ISSUE 3 REV. 0 DATED 03 FEB 2021 AJL NO.: _____ AIRCRAFT HOURS: : _____ REMARKS: <i>NIL FLIGHT</i>	-	 	<i>15/11/2023</i>
16	<b>DATE: 16 NOVEMBER 2023</b> AIRWORTHINESS CHECK TO BE CARRIED OUT NOTE: VALID UNTIL 72 HOURS FROM LAST AIRWORTHINESS CHECK CARRIED OUT IF AIRCRAFT NOT FLOWN. REF: AMP RMPAOF/CAMO/AMP/AW139 ISSUE 3 REV. 0 DATED 03 FEB 2021 AJL NO.: _____ AIRCRAFT HOURS: : _____ REMARKS: <i>NIL FLIGHT</i>	-	 	<i>16/11/23</i>
17	<b>DATE: 17 NOVEMBER 2023</b> AIRWORTHINESS CHECK TO BE CARRIED OUT NOTE: VALID UNTIL 72 HOURS FROM LAST AIRWORTHINESS CHECK CARRIED OUT IF AIRCRAFT NOT FLOWN. REF: AMP RMPAOF/CAMO/AMP/AW139 ISSUE 3 REV. 0 DATED 03 FEB 2021 AJL NO.: _____ AIRCRAFT HOURS: : _____ REMARKS: <i>NIL FLIGHT</i>	-	 	<i>17/11/23</i>
18	<b>DATE: 18 NOVEMBER 2023</b> AIRWORTHINESS CHECK TO BE CARRIED OUT NOTE: VALID UNTIL 72 HOURS FROM LAST AIRWORTHINESS CHECK CARRIED OUT IF AIRCRAFT NOT FLOWN. REF: AMP RMPAOF/CAMO/AMP/AW139 ISSUE 3 REV. 0 DATED 03 FEB 2021 AJL NO.: _____ AIRCRAFT HOURS: : _____ REMARKS: <i>NIL FLIGHT</i>	-	 	<i>18/11/2023</i>

- \*Certifies that the work specified above, except as otherwise specified, was carried out in accordance with CAA Malaysia Requirements and in respect to that work the aircraft / aircraft component is considered ready for release to service. **AMO/2018/02**
- \*Certifies that the work specified above, except as otherwise specified, was carried out in accordance with \_\_\_\_\_ and in respect to that work the aircraft / aircraft component is considered ready for release to service.

TICK  WHERE APPLICABLE

REP	REP	REP	REP	REP	REP	REP	REP	REP	REP	REP	REP	REP	REP	REP	REP	REP	REP	REP	REP
-----	-----	-----	-----	-----	-----	-----	-----	-----	-----	-----	-----	-----	-----	-----	-----	-----	-----	-----	-----



CLIENT/OWNER: ROYAL MALAYSIA POLICE AIRCRAFT TYPE: AW139 REGISTRATION: 9M-PMD BASE/FACILITY: WMSA DATE IN: REFER WORKPACK OUT: REFER WORKPACK	SERIAL NO. AIRCRAFT #1 ENGINE: #2 ENGINE:	HOURS 31809 PCE-KB2112 PCE-KB2092	LDG/CYCLE REFER WORKPACK REFER WORKPACK REFER WORKPACK	WORKSHEET NO: 17379-001 WORK/INSP/DESC: AIRWORTHINESS CHECK WORKPACK REF: 9M-PMD-17379 AJL REF NO.: REFER WORKPACK SHEET: 4 OF 5
---	--	--	---	--

Reason for raising:  
AIRWORTHINESS CHECK PERFORM I.A.W AIRCRAFT MAINTENANCE PROGRAM RMPAOF/CAMO/AMP/AW139 ISSUE 3 REV. 0 DATED 03 FEB 2021 OR LATER APPROVED REVISIONS. DUE AT: NOVEMBER 2023

Raised by and date:  
CAMO; Hanis  
20/10/2023

Other requirements/information:  
PLEASE NOTE "NIL FLYING" ON THE DATE AIRCRAFT NOT FLYING AND NOT CARRIED OUT.

Item	Description	Technician	* Eng. CRS	Date
19	<p><b>DATE: 19 NOVEMBER 2023</b></p> <p>AIRWORTHINESS CHECK TO BE CARRIED OUT NOTE: VALID UNTIL 72 HOURS FROM LAST AIRWORTHINESS CHECK CARRIED OUT IF AIRCRAFT NOT FLOWN. REF: AMP RMPAOF/CAMO/AMP/AW139 ISSUE 3 REV. 0 DATED 03 FEB 2021 AJL NO.: <u>          -          </u> AIRCRAFT HOURS: <u>          -          </u></p> <p>REMARKS: <b>NIL FLIGHT</b></p>	-		19/11/2023
20	<p><b>DATE: 20 NOVEMBER 2023</b></p> <p>AIRWORTHINESS CHECK TO BE CARRIED OUT NOTE: VALID UNTIL 72 HOURS FROM LAST AIRWORTHINESS CHECK CARRIED OUT IF AIRCRAFT NOT FLOWN. REF: AMP RMPAOF/CAMO/AMP/AW139 ISSUE 3 REV. 0 DATED 03 FEB 2021 AJL NO.: <u>          -          </u> AIRCRAFT HOURS: <u>          -          </u></p> <p>REMARKS: <b>NIL FLIGHT</b></p>	-		20/11/23
21	<p><b>DATE: 21 NOVEMBER 2023</b></p> <p>AIRWORTHINESS CHECK TO BE CARRIED OUT NOTE: VALID UNTIL 72 HOURS FROM LAST AIRWORTHINESS CHECK CARRIED OUT IF AIRCRAFT NOT FLOWN. REF: AMP RMPAOF/CAMO/AMP/AW139 ISSUE 3 REV. 0 DATED 03 FEB 2021 AJL NO.: <u>01423</u> AIRCRAFT HOURS: <u>1835:25</u></p> <p>REMARKS: <b>FOUND SATISFACTORY.</b></p>			21/11/25
22	<p><b>DATE: 22 NOVEMBER 2023</b></p> <p>AIRWORTHINESS CHECK TO BE CARRIED OUT NOTE: VALID UNTIL 72 HOURS FROM LAST AIRWORTHINESS CHECK CARRIED OUT IF AIRCRAFT NOT FLOWN. REF: AMP RMPAOF/CAMO/AMP/AW139 ISSUE 3 REV. 0 DATED 03 FEB 2021 AJL NO.: <u>01424</u> AIRCRAFT HOURS: <u>1837:30</u></p> <p>REMARKS: <b>CARRIED OUT - FOUND SATISFACTORY.</b></p>			22/11/23
23	<p><b>DATE: 23 NOVEMBER 2023</b></p> <p>AIRWORTHINESS CHECK TO BE CARRIED OUT NOTE: VALID UNTIL 72 HOURS FROM LAST AIRWORTHINESS CHECK CARRIED OUT IF AIRCRAFT NOT FLOWN. REF: AMP RMPAOF/CAMO/AMP/AW139 ISSUE 3 REV. 0 DATED 03 FEB 2021 AJL NO.: <u>01425</u> AIRCRAFT HOURS: <u>1838:35</u></p> <p>REMARKS: <b>NO SATIS</b></p>			23/11/2023
24	<p><b>DATE: 24 NOVEMBER 2023</b></p> <p>AIRWORTHINESS CHECK TO BE CARRIED OUT NOTE: VALID UNTIL 72 HOURS FROM LAST AIRWORTHINESS CHECK CARRIED OUT IF AIRCRAFT NOT FLOWN. REF: AMP RMPAOF/CAMO/AMP/AW139 ISSUE 3 REV. 0 DATED 03 FEB 2021 AJL NO.: <u>          -          </u> AIRCRAFT HOURS: <u>          -          </u></p> <p>REMARKS: <b>NIL FLIGHT</b></p>	-		24/11/23

Certifies that the work specified above, except as otherwise specified, was carried out in accordance with CAA Malaysia Requirements and in respect to that work the aircraft / aircraft component is considered ready for release to service. **AMO2018/02**

\* Certifies that the work specified above, except as otherwise specified, was carried out in accordance with \_\_\_\_\_ and in respect to that work the aircraft / aircraft component is considered ready for release to service.

TICK  WHERE APPLICABLE

ISSUE	REV	DATE	BY	REASON	APPROVED	REVISIONS	REMARKS	DATE	BY	REASON	DATE	BY	REASON	DATE	BY	REASON	DATE	BY	REASON
-------	-----	------	----	--------	----------	-----------	---------	------	----	--------	------	----	--------	------	----	--------	------	----	--------



CLIENT/OWNER: ROYAL MALAYSIA POLICE AIRCRAFT TYPE: AW139 REGISTRATION: 9M-PMD BASE/FACILITY: WMSA DATE IN: REFER WORKPACK OUT: REFER WORKPACK	SERIAL NO. AIRCRAFT 31809 #1 ENGINE: PCE-KB2112 #2 ENGINE: PCE-KB2092	HOURS REFER WORKPACK REFER WORKPACK REFER WORKPACK	LDG/CYCLE NG / N1 NF / N2	WORKSHEET NO: 17379-001 WORK/INSP/DESC: AIRWORTHINESS CHECK WORKPACK REF: 9M-PMD-17379 AJL REF NO.: REFER WORKPACK SHEET: 5 OF 5
---	--	---	---------------------------------	--

Reason for raising: AIRWORTHINESS CHECK PERFORM I.A.W AIRCRAFT MAINTENANCE PROGRAM RMPAOF/CAMO/AMP/AW139 ISSUE 3 REV. 0 DATED 03 FEB 2021 OR LATER APPROVED REVISIONS. DUE AT: NOVEMBER 2023	Raised by and date: CAMO; Hanis 20/10/2023	Other requirements/information: PLEASE NOTE "NIL FLYING" ON THE DATE AIRCRAFT NOT FLYING AND NOT CARRIED OUT.
---	--	---

Item	Description	Technician	* Eng. CRS	Date
25	<p><b>DATE: 25 NOVEMBER 2023</b></p> <p>AIRWORTHINESS CHECK TO BE CARRIED OUT NOTE: VALID UNTIL 72 HOURS FROM LAST AIRWORTHINESS CHECK CARRIED OUT IF AIRCRAFT NOT FLOWN. REF: AMP RMPAOF/CAMO/AMP/AW139 ISSUE 3 REV. 0 DATED 03 FEB 2021</p> <p>AJL NO.: _____ AIRCRAFT HOURS: : _____</p> <p>REMARKS: <b>NIL FLIGHT</b></p>	-	 	25/11/23
26	<p><b>DATE: 26 NOVEMBER 2023</b></p> <p>AIRWORTHINESS CHECK TO BE CARRIED OUT NOTE: VALID UNTIL 72 HOURS FROM LAST AIRWORTHINESS CHECK CARRIED OUT IF AIRCRAFT NOT FLOWN. REF: AMP RMPAOF/CAMO/AMP/AW139 ISSUE 3 REV. 0 DATED 03 FEB 2021</p> <p>AJL NO.: _____ AIRCRAFT HOURS: : _____</p> <p>REMARKS: <b>NIL FLIGHT</b></p>	-	 	26/11/2023
27	<p><b>DATE: 27 NOVEMBER 2023</b></p> <p>AIRWORTHINESS CHECK TO BE CARRIED OUT NOTE: VALID UNTIL 72 HOURS FROM LAST AIRWORTHINESS CHECK CARRIED OUT IF AIRCRAFT NOT FLOWN. REF: AMP RMPAOF/CAMO/AMP/AW139 ISSUE 3 REV. 0 DATED 03 FEB 2021</p> <p>AJL NO.: <u>1846-10 Mj 01427</u> AIRCRAFT HOURS: : <u>1839:50</u></p> <p>REMARKS: <b>FOUND SATISFACTORY</b></p>	 8201	 	27/11/23
28	<p><b>DATE: 28 NOVEMBER 2023</b></p> <p>AIRWORTHINESS CHECK TO BE CARRIED OUT NOTE: VALID UNTIL 72 HOURS FROM LAST AIRWORTHINESS CHECK CARRIED OUT IF AIRCRAFT NOT FLOWN. REF: AMP RMPAOF/CAMO/AMP/AW139 ISSUE 3 REV. 0 DATED 03 FEB 2021</p> <p>AJL NO.: <u>1846-10 01428</u> AIRCRAFT HOURS: : <u>1840:10</u></p> <p>REMARKS: <b>FOUND SATISFACTORY</b></p>		 	28/11/23
29	<p><b>DATE: 29 NOVEMBER 2023</b></p> <p>AIRWORTHINESS CHECK TO BE CARRIED OUT NOTE: VALID UNTIL 72 HOURS FROM LAST AIRWORTHINESS CHECK CARRIED OUT IF AIRCRAFT NOT FLOWN. REF: AMP RMPAOF/CAMO/AMP/AW139 ISSUE 3 REV. 0 DATED 03 FEB 2021</p> <p>AJL NO.: <u>01429</u> AIRCRAFT HOURS: : <u>1843:55</u></p> <p>REMARKS: <b>FOUND SATISFACTORY</b></p>	 8095	 	29/11/23
30	<p><b>DATE: 30 NOVEMBER 2023</b></p> <p>AIRWORTHINESS CHECK TO BE CARRIED OUT NOTE: VALID UNTIL 72 HOURS FROM LAST AIRWORTHINESS CHECK CARRIED OUT IF AIRCRAFT NOT FLOWN. REF: AMP RMPAOF/CAMO/AMP/AW139 ISSUE 3 REV. 0 DATED 03 FEB 2021</p> <p>AJL NO.: <u>01430</u> AIRCRAFT HOURS: : <u>1846:45</u></p> <p>REMARKS: <b>FOUND SATISFACTORY</b></p>		   30/11/23	30/11/23

- \*Certifies that the work specified above, except as otherwise specified, was carried out in accordance with CAA Malaysia Requirements and in respect to that work the aircraft / aircraft component is considered ready for release to service. **AMO/2016/02**
- \*Certifies that the work specified above, except as otherwise specified, was carried out in accordance with \_\_\_\_\_ and in respect to that work the aircraft / aircraft component is considered ready for release to service.

TICK ✓ WHERE APPLICABLE

REP	EN	DE	IN	MA	TE	AD	MA	RE	DI	TE	EN	AM	EN	EN	EN	EN	EN	EN	EN
-----	----	----	----	----	----	----	----	----	----	----	----	----	----	----	----	----	----	----	----



CLIENT/OWNER: ROYAL MALAYSIA POLICE AIRCRAFT TYPE: AW139 REGISTRATION: 9M-PMD BASE/FACILITY: WMSA DATE IN: REFER WORKPACK OUT: REFER WORKPACK	SERIAL NO.	HOURS	LDG/CYCLE	WORKSHEET NO: 17379-001	
	AIRCRAFT	31809	REFER WORKPACK		WORK/INSP/DESC: AIRWORTHINESS CHECK
	#1 ENGINE:	PCE-KB2112	REFER WORKPACK		WORKPACK REF: 9M-PMD-17379
	#2 ENGINE:	PCE-KB2092	REFER WORKPACK		AJL REF NO.: REFER WORKPACK
			NG / N1      NF / N2	SHEET: 1 OF 1	

Reason for raising: AIRWORTHINESS CHECK PERFORM I.A.W AIRCRAFT MAINTENANCE PROGRAM RMPAOF/CAMO/AMP/AW139 ISSUE 3 REV. 0 DATED 03 FEB 2021 OR LATER APPROVED REVISIONS. DUE AT: NOVEMBER 2023	Raised by and date: CAMO; Hanis 20/10/2023	Other requirements/information: NIL
---	--	--

Item	Part No	Description	Serial Number		Qty	Position	Reason	Lifed Item Information TSN/TSO/DUE/TIMEX	Release Reference
			Off	On					
[Table content is crossed out with a diagonal line]									

NAME	FIRM	SIGN & APPROVAL	DATE
AHMUDIN FAZRIN BIN ANUAR	GALAXY		30/11/23



\*Certifies that the work specified above, except as otherwise specified, was carried out in accordance with CAA Malaysia Requirements and in respect to that work the aircraft / aircraft component is considered ready for release to service. **AMO/2016/02**

\*Certifies that the work specified above, except as otherwise specified, was carried out in accordance with \_\_\_\_\_ and in respect to that work the aircraft / aircraft component is considered ready for release to service.

TICK ✓ WHERE APPLICABLE

WORK ORDER NO.	ENGINE	PROPULSION	AVIONICS	ELECTRICAL	STRUCTURE	INTERIORS	EXTERIORS	LANDING GEAR	ENGINE	PROPULSION	AVIONICS	ELECTRICAL	STRUCTURE	INTERIORS	EXTERIORS	LANDING GEAR	ENGINE	PROPULSION	AVIONICS	ELECTRICAL	STRUCTURE	INTERIORS	EXTERIORS	LANDING GEAR
----------------	--------	------------	----------	------------	-----------	-----------	-----------	--------------	--------	------------	----------	------------	-----------	-----------	-----------	--------------	--------	------------	----------	------------	-----------	-----------	-----------	--------------