

# AIRCRAFT ACCEPTANCE / HANDOVER INSPECTION FORM

A/C TYPE:	ROBINSON R44
A/C REG:	N8372K
A/C SN:	1099
CLIENT:	MEDITECH

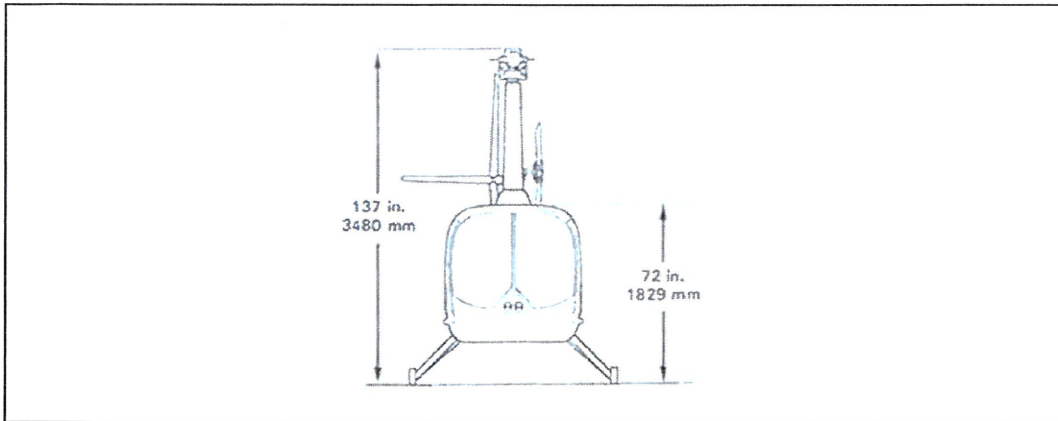





FIGURE 1: NOSE AREA

NO	NOTES/FINDINGS	INSPECTED BY	VERIFIED BY
1	NILL	 	

# AIRCRAFT ACCEPTANCE / HANDOVER INSPECTION FORM

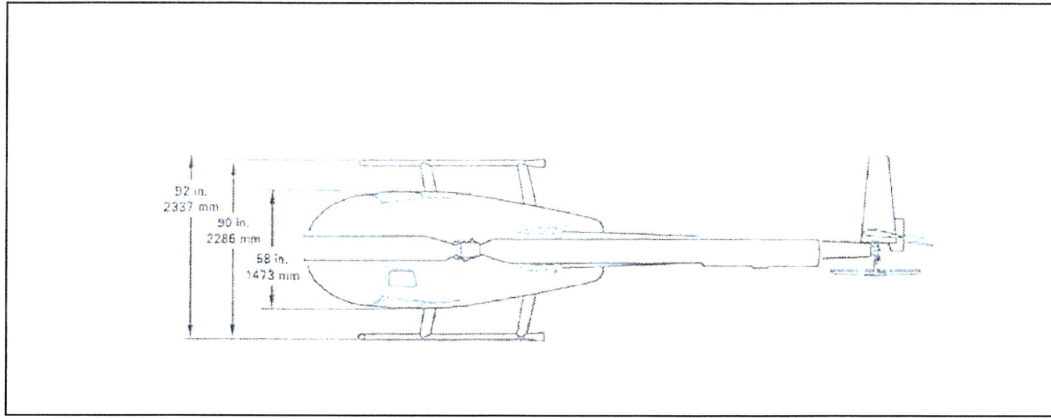





FIGURE 2: TOP AREA

NO	NOTES/FINDINGS	INSPECTED BY	VERIFIED BY
1	NIL	 	

# AIRCRAFT ACCEPTANCE / HANDOVER INSPECTION FORM

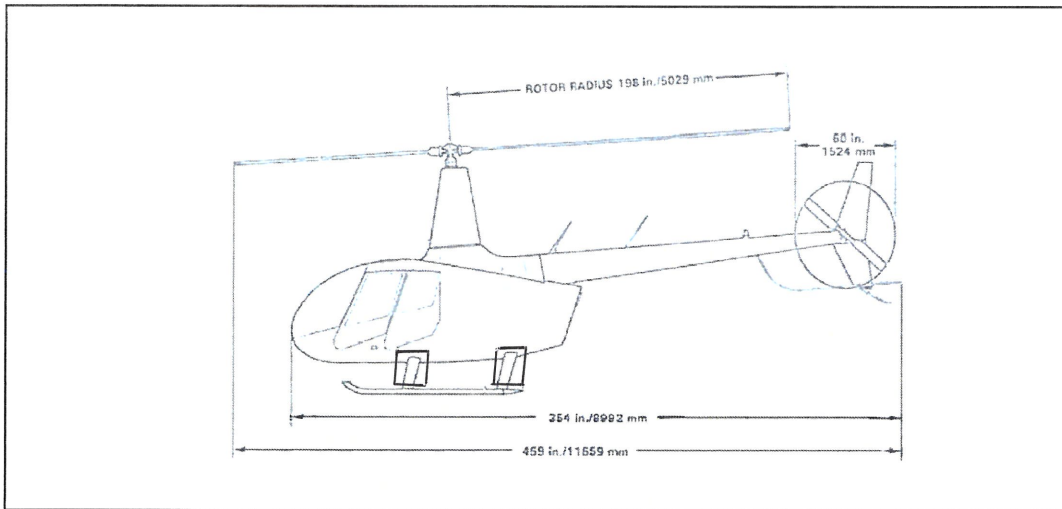





FIGURE 3: LEFT SIDE AREA

NO	NOTES/FINDINGS	INSPECTED BY	VERIFIED BY
1	FWD AND AFT SKID FAIRING NOT INSTALLED	 	

# AIRCRAFT ACCEPTANCE / HANDOVER INSPECTION FORM

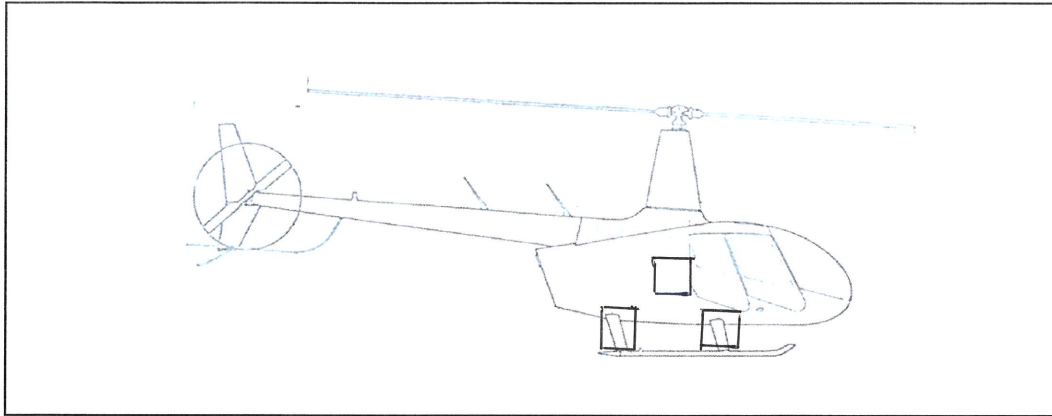



FIGURE 4: RIGHT SIDE AREA

NO	NOTES/FINDINGS	INSPECTED BY	VERIFIED BY
1	FWD AND AFT SKID FAIRING NOT INSTALLED		
2	TRACE OF PAINT PEEL OFF NEAR RIGHT AFT DOOR		

# AIRCRAFT ACCEPTANCE / HANDOVER INSPECTION FORM

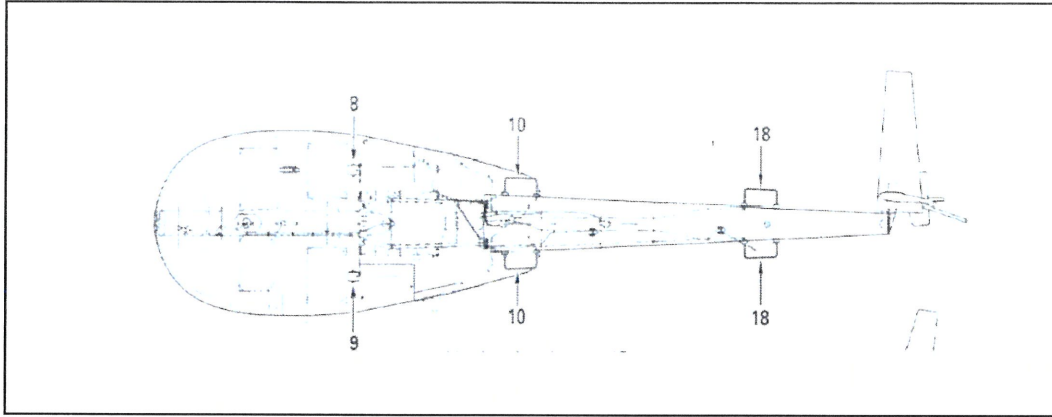



FIGURE 5: BELLY AREA

NO	NOTES/FINDINGS	INSPECTED BY	VERIFIED BY
1	NIL		

# AIRCRAFT ACCEPTANCE / HANDOVER INSPECTION FORM

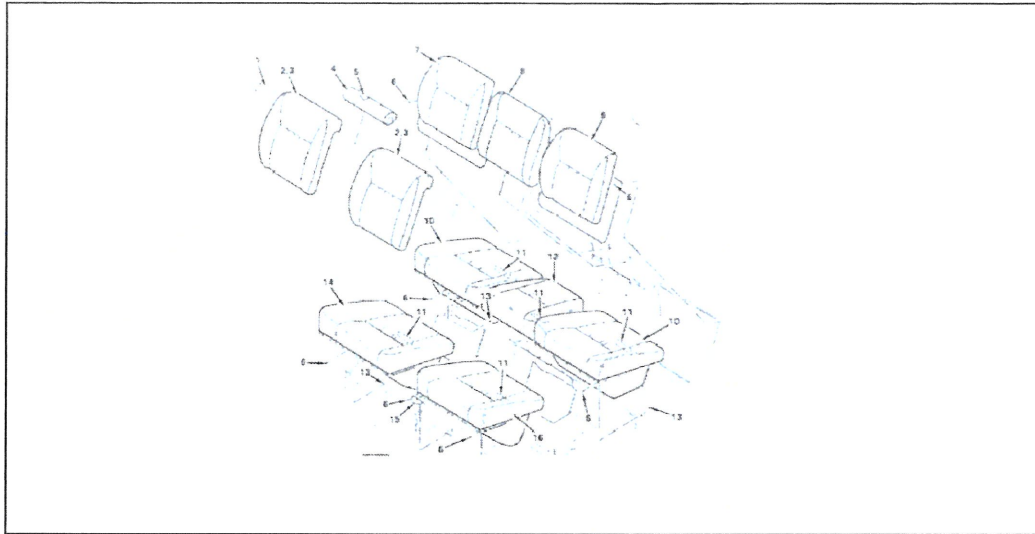







FIGURE 6: SEATS



NO	NOTES/FINDINGS	INSPECTED BY	VERIFIED BY
1	NIL		

# AIRCRAFT ACCEPTANCE / HANDOVER INSPECTION FORM

COCKPIT



NO	NOTES/FINDINGS	CHECKED BY	VERIFIED BY
1	NIL	 	

CABIN



NO	NOTES/FINDINGS	CHECKED BY	VERIFIED BY
1	NIL	 	

# AIRCRAFT ACCEPTANCE / HANDOVER INSPECTION FORM

## BAGGAGE COMPARTMENT

NO	NOTES/FINDINGS	CHECKED BY	VERIFIED BY
1	NIL	 	



## OTHERS

NO	NOTES/FINDINGS	CHECKED BY	VERIFIED BY
1	NIL	 	



# AIRCRAFT ACCEPTANCE / HANDOVER INSPECTION FORM

LOOSE ITEM CHECK LIST

NO	NOTES/FINDINGS	CHECKED BY	VERIFIED BY
1	GROUND HANDLING WHEEL		
2	PITOT COVER		
3	AIRCRAFT POH		
4	2 UNIT OF HEADSET		
5	WINDOW SHADE		
6	MRB TIE DOWN KIT		
7	AIRCRAFT KEY		

**SECTION A: ACCEPTANCE FROM CLIENT**

I hereby verify that a physical inspection has been carried out with the above notes/findings, prior to aircraft handing-over to Galaxy Aerospace (M) Sdn Bhd :

GAM Representative Signature : 

NAME : MOHAMMAD ARIF

DATE : 31/5/2024

I hereby acknowledge handing-over of the aircraft to Galaxy Aerospace (M) Sdn. Bhd. with the above-mentioned notes/findings after verification with Galaxy Aerospace representative:

CLIENT Representative Signature: 

NAME: YANG KUANG TING

DATE: 31/5/2024

# AIRCRAFT ACCEPTANCE / HANDOVER INSPECTION FORM

**SECTION B: HANDOVER TO CLIENT**

I hereby verify that the required inspection/defect and findings rectification/loose items counts have been performed and CLIENT been advice accordingly:

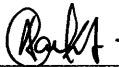
GAM Representative Signature : \_\_\_\_\_ 

NAME : MOHAMMAD ARIF

DATE : 07/06/2024

I hereby acknowledge acceptance of the aircraft and subject mentioned above after verification with Galaxy Aerospace (M) representative:

CLIENT Representative Signature: \_\_\_\_\_ 

NAME : YANA KWANA YINK

DATE : 8/6/24



