

INTERNATIONAL STANDARD

ISO 6789-1

First edition
2017-02

Assembly tools for screws and nuts — Hand torque tools —

Part 1: Requirements and methods for design conformance testing and quality conformance testing: minimum requirements for declaration of conformance

*Outils de manoeuvre pour vis et écrous — Outils dynamométriques à
commande manuelle —*

*Partie 1: Exigences et méthodes d'essai pour vérifier la conformité
de conception et la conformité de qualité: exigences minimales pour
déclaration de conformité*



Please share your feedback about
the standard. Scan the QR code
with your phone or click the link

[Customer Feedback Form](#)



Reference number
ISO 6789-1:2017(E)

© ISO 2017

ISO 6789-1:2017(E)



COPYRIGHT PROTECTED DOCUMENT

© ISO 2017, Published in Switzerland

All rights reserved. Unless otherwise specified, no part of this publication may be reproduced or utilized otherwise in any form or by any means, electronic or mechanical, including photocopying, or posting on the internet or an intranet, without prior written permission. Permission can be requested from either ISO at the address below or ISO's member body in the country of the requester.

ISO copyright office
Ch. de Blandonnet 8 • CP 401
CH-1214 Vernier, Geneva, Switzerland
Tel. +41 22 749 01 11
Fax +41 22 749 09 47
copyright@iso.org
www.iso.org

Contents

Page

Foreword	iv
Introduction	vi
1 Scope	1
2 Normative references	1
3 Terms, definitions and symbols	1
3.1 Terms and definitions.....	1
3.2 Symbols, designations and units.....	3
4 Classification	3
5 Requirements	3
5.1 Design conformance testing.....	3
5.1.1 General.....	3
5.1.2 Maximum torque values.....	4
5.1.3 Specified torque range.....	4
5.1.4 Scales, dials and displays.....	4
5.1.5 Maximum permissible deviation.....	5
5.1.6 Overloading test.....	5
5.1.7 Endurance test.....	5
5.1.8 Effect of geometric changes.....	6
5.2 Quality conformance testing.....	7
5.3 Conformance test during use.....	7
6 Torque measurement	7
6.1 Torque measurement system.....	7
6.2 Application of torque.....	8
6.3 Ambient conditions.....	8
6.4 Measurement requirements.....	9
6.5 Measurement sequence.....	11
6.5.1 General.....	11
6.5.2 Indicating torque tools, Type I.....	11
6.5.3 Setting torque tools, Type II.....	11
7 Calculation of deviation	12
7.1 General.....	12
7.2 Calculation example 1.....	12
7.3 Calculation example 2.....	13
8 Declaration of conformance	14
9 Marking	15
Annex A (normative) Examples of indicating torque tools (Type I)	16
Annex B (normative) Examples of setting torque tools (Type II)	17
Annex C (informative) Measurement sequence flowchart for torque tools	19
Bibliography	22

ISO 6789-1:2017(E)

Foreword

ISO (the International Organization for Standardization) is a worldwide federation of national standards bodies (ISO member bodies). The work of preparing International Standards is normally carried out through ISO technical committees. Each member body interested in a subject for which a technical committee has been established has the right to be represented on that committee. International organizations, governmental and non-governmental, in liaison with ISO, also take part in the work. ISO collaborates closely with the International Electrotechnical Commission (IEC) on all matters of electrotechnical standardization.

The procedures used to develop this document and those intended for its further maintenance are described in the ISO/IEC Directives, Part 1. In particular the different approval criteria needed for the different types of ISO documents should be noted. This document was drafted in accordance with the editorial rules of the ISO/IEC Directives, Part 2 (see www.iso.org/directives).

Attention is drawn to the possibility that some of the elements of this document may be the subject of patent rights. ISO shall not be held responsible for identifying any or all such patent rights. Details of any patent rights identified during the development of the document will be in the Introduction and/or on the ISO list of patent declarations received (see www.iso.org/patents).

Any trade name used in this document is information given for the convenience of users and does not constitute an endorsement.

For an explanation on the voluntary nature of standards, the meaning of ISO specific terms and expressions related to conformity assessment, as well as information about ISO's adherence to the World Trade Organization (WTO) principles in the Technical Barriers to Trade (TBT) see the following URL: www.iso.org/iso/foreword.html.

This document was prepared by Technical Committee ISO/TC 29, *Small tools*, Subcommittee SC 10, *Assembly tools for screws and nuts, pliers and nippers*.

This first edition of ISO 6789-1, together with ISO 6789-2, cancels and replaces ISO 6789:2003 which has been technically revised with changes as follows.

- a) ISO 6789:2003 has been divided into two parts. This document specifies the requirements for design and manufacture including the content of a declaration of conformance. ISO 6789-2 specifies the requirements for traceable certificates of calibration. It includes a method for calculation of uncertainties and provides a method for calibration of the torque measurement device used for calibrating hand torque tools.
- b) The output drive designation of torque tools is expanded to include hexagonal and other output drives.
- c) The definition of the torque range of the tools has been changed.
- d) The rate of loading (shown by the time to achieve the last 20 %) has been changed.
- e) The importance of avoiding parasitic forces has been emphasized.
- f) Explanatory flowcharts for the measurement sequence of different torque tools have been added in [Annex C](#).
- g) The requirement for a “declaration of conformance” that the torque tool conforms with this document has been added.
- h) The requirement for a “certificate of calibration” has been removed, recognizing that manufacturers’ calibration certificates have not previously contained enough information to be traceable calibration certificates.
- i) ISO 6789 has been editorially updated and restructured.

j) [Figures B.2, B.3, B.5](#) and [B.6](#) have been changed.

A list of all parts in the ISO 6789 series can be found on the ISO website.

ISO 6789-1:2017(E)

Introduction

The revision of ISO 6789:2003 has been designed to achieve the following improvements.

ISO 6789 has been split to provide two levels of documentation. It recognizes the different needs of different users of the standard.

This document continues to provide designers and manufacturers with relevant minimum requirements for the development, production and documentation of hand torque tools.

ISO 6789-2 provides detailed methods for calculation of uncertainties and requirements for calibrations. This will allow users of calibration services to more easily compare the calibrations from different laboratories. Additionally, minimum requirements for the calibration of torque measurement devices are described in ISO 6789-2:2017, Annex C.

Assembly tools for screws and nuts — Hand torque tools —

Part 1:

Requirements and methods for design conformance testing and quality conformance testing: minimum requirements for declaration of conformance

1 Scope

This document specifies the conformance testing and marking requirements for hand torque tools used for controlled tightening of screws and nuts. It also specifies the minimum requirements for declaration of conformance for hand torque tools.

This document applies to hand torque tools which are classified as indicating torque tools (Type I) and setting torque tools (Type II).

NOTE Hand torque tools covered by this document are those identified in ISO 1703:2005 by reference numbers 6 1 00 11 0, 6 1 00 11 1 and 6 1 00 12 0, 6 1 00 12 1 and 6 1 00 14 0, 6 1 00 15 0. ISO 1703 is currently under revision. In the next edition, torque tools will be moved to an own clause, and with this change the reference numbers will also change and additional reference numbers will be added.

This document does not specify requirements of calibration certificates for hand torque tools. These are described in ISO 6789-2.

2 Normative references

The following documents are referred to in the text in such a way that some or all of their content constitutes requirements of this document. For dated references, only the edition cited applies. For undated references, the latest edition of the referenced document (including any amendments) applies.

ISO 1173, *Assembly tools for screws and nuts — Drive ends for hand- and machine-operated screwdriver bits and connecting parts — Dimensions, torque testing*

ISO 1174-1, *Assembly tools for screws and nuts — Driving squares — Part 1: Driving squares for hand socket tools*

ISO 6789-2:2017, *Assembly tools for screws and nuts — Hand torque tools — Part 2: Requirements for calibration and determination of measurement uncertainty*

ISO/IEC 17025, *General requirements for the competence of testing and calibration laboratories*

3 Terms, definitions and symbols

3.1 Terms and definitions

For the purposes of this document, the following terms and definitions apply.

ISO and IEC maintain terminological databases for use in standardization at the following addresses:

— IEC Electropedia: available at <http://www.electropedia.org/>

— ISO Online browsing platform: available at <http://www.iso.org/obp>

ISO 6789-1:2017(E)

3.1.1 design conformance test

technical examination of conformance with those requirements to be met during design or modification of hand torque tools

3.1.2 quality conformance test

technical examination of conformance with those requirements to be met during manufacture of hand torque tools

3.1.3 declaration of conformance

documented information provided by the manufacturer that the torque tool complies with the requirements of this document

3.1.4 maximum permissible deviation

maximum value of relative measurement deviation of the observed torque value on the torque measurement device measured as a percentage of the target torque value on the torque tool

Note 1 to entry: Sometimes the term “accuracy” is still used in place of the term “maximum permissible deviation” which is, however, not technically correct. The concept “measurement accuracy” is not a quantity and is not given a numerical quantity value. A measurement is said to be more accurate when it offers a smaller measurement deviation.

Note 2 to entry: Maximum permissible deviation is different from measurement error which is used in ISO 6789-2 and defined in ISO/IEC Guide 99.

3.1.5 torque measurement system

combination of a torque measurement device and the loading system for application of torque that acts as the measurement standard for the hand torque tool

Note 1 to entry: A calibration system as defined in ISO 6789-2 can also be used as a torque measurement system in this document.

3.1.6 torque measurement device

working measurement standard provided either mechanically or by an electronic torque transducer and display

3.1.7 indicating torque tool (Type I)

tool that indicates by means of a mechanical scale, dial or electronic display, the value of torque exerted by the tool at the output drive

3.1.8 setting torque tool (Type II)

tool sensing torque transmitted by comparing the torque applied with a self-contained standard and signalling the transmission of the pre-selected value by a physical impulse, with or without audible signal, causing a temporary reduction in the torque applied

3.1.9 adjustable graduated torque tool (Type II, Class A, Class D and Class G)

tool designed to be adjusted by the user, which has a scale or a display to assist adjustment

3.1.10 adjustable non-graduated torque tool (Type II, Class C and Class F)

tool designed to be adjusted by the user with the aid of a torque measurement system

3.1.11

torque tool with fixed adjustment (Type II, Class B and Class E)

tool not designed to be adjusted by the user, i.e. having a single setting

3.2 Symbols, designations and units

The designations used in this document are indicated in [Table 1](#).

Table 1 — Symbols, designations and units

Symbol	Designation	Unit
a_d	Relative deviation of the torque tool from the target torque	%
X_t	Value of torque desired, which may be the indicated, set, nominal value, depending on the type and class of the torque tool	N · m
X_o	Observed value shown by the torque measurement device	N · m

4 Classification

The hand torque tools to which this document applies are classified as follows.

- a) Indicating torque tools (Type I; see [Annex A](#)):
 - 1) Class A: Wrench, torsion or flexion bar;
 - 2) Class B: Wrench, rigid housing, with scale or dial or display;
 - 3) Class C: Wrench, rigid housing and electronic measurement;
 - 4) Class D: Screwdriver, with scale or dial or display;
 - 5) Class E: Screwdriver, with electronic measurement;
- b) Setting torque tools (Type II; see [Annex B](#)):
 - 1) Class A: Wrench, adjustable, graduated or with display;
 - 2) Class B: Wrench, fixed adjustment;
 - 3) Class C: Wrench, adjustable, non-graduated;
 - 4) Class D: Screwdriver, adjustable, graduated or with display;
 - 5) Class E: Screwdriver, fixed adjustment;
 - 6) Class F: Screwdriver, adjustable, non-graduated;
 - 7) Class G: Wrench, flexion bar, adjustable, graduated

5 Requirements

5.1 Design conformance testing

5.1.1 General

The manufacturer shall verify that the torque tool is in conformity with [5.1.2](#) to [5.1.8](#).

ISO 6789-1:2017(E)

5.1.2 Maximum torque values

The size of the output drive limits the maximum torque value of the respective torque tool. The assignment is carried out according to the values given in [Table 2](#). For outputs not specified in [Table 2](#), the size of the output drive is determined by the maximum torque of the respective torque tool and shall comply with the requirements given in [5.1.6](#) and [5.1.8](#).

Table 2 — Maximum torque values of the torque tool

Square output drive nominal size ^a	Hexagonal output drive nominal size ^b	Maximum torque value N·m
—	3	4
—	4	10
—	5,5	25
6,3	6,3	30
—	8	70
10	—	135
—	11,2	200
12,5	12,5	340
20	—	1 000
25	—	2 100
^a Dimensions in accordance with ISO 1174-1. ^b Dimensions in accordance with ISO 1173.		

5.1.3 Specified torque range

The requirements and methods in this document cover a specified torque range, where the range depends on type and class of the torque tool.

The torque range or value is selected for the different torque tools as follows.

- Indicating torque tools of Type I (Classes A, B and D): From the lowest marked value to 100 % of the maximum torque value of the respective tool.
- Indicating torque tools of Type I (Classes C and E): As specified by the manufacturer.
- Setting torque tools of Type II (Classes A, D and G): From the lowest marked value to 100 % of the maximum torque value of the respective tool.
- Setting torque tools of Type II (Classes B, C, E and F): As specified by the manufacturer.

5.1.4 Scales, dials and displays

For scales and dials, the increment between two graduation marks shall not exceed 5 % of the maximum torque value of the torque tool.

For electronic displays, the resolution shall not exceed 1/4 of the maximum permissible relative deviation of the torque tool at each target value.

For indicating torque tools of Type I (Classes A, B and D), the scales or dials shall be marked with a zero position. The range between zero and the lowest specified torque value shall be marked on or near the dial or scale in a way to make clear to the user that this range is not within the specified torque range. Alternatively, the scale, dial or display shall be identified in some way to indicate the specified torque range to the user.

For indicating torque tools of Type I (Classes C and E), the range between zero and the lower value of the range specified by the manufacturer shall be identified in some way to make clear to the user that this range is not in the specified range.

The design of scales, dials and displays has a significant influence on the calibration uncertainty of a torque tool. Designers are recommended to take guidance from ISO 6789-2:2017, 6.2.1.

5.1.5 Maximum permissible deviation

Each result for a torque tool, recorded in accordance with [Clause 6](#) and calculated in accordance with [Clause 7](#), shall lie within the respective maximum permissible relative deviation for the type and class of that tool stated in [Tables 3](#) and [4](#).

Where a manufacturer claims a smaller maximum permissible relative deviation than stated in [Tables 3](#) and [4](#), each result shall lie within the claimed maximum permissible relative deviation.

For determining conformance with this subclause, the influence of the uncertainty of the torque tool and of the torque measurement device shall not be considered.

Table 3 — Maximum permissible relative deviation (Type I)

Class	Maximum torque value	
	≤10 N·m	>10 N·m
A and D	±6 %	
B, C and E	±6 %	±4 %
If a tool is operating in both directions, the maximum permissible relative deviation shall be met in each direction specified by the manufacturer.		

Table 4 — Maximum permissible relative deviation (Type II)

Class	Maximum torque value	
	≤10 N·m	>10 N·m
A, B and C	±6 %	±4 %
D, E, F and G	±6 %	
If a tool is operating in both directions, the maximum permissible relative deviation shall be met in each direction specified by the manufacturer.		

5.1.6 Overloading test

All torque tools to be tested shall be loaded three times in each direction of operation to a torque value not less than 125 % of the maximum torque value or at nominal capacity for setting torque tools of Type II (Classes D, E and F). For Type II (Classes A, C, D, F and G), the test is performed after setting the tool to 100 % of the maximum torque value. This test does not apply to limiting torque tools.

After the overloading test, the torque tool shall still be within the maximum permissible relative deviation specified in [5.1.5](#) when tested in accordance with [Clause 6](#) and shall show no physical damage that can be detrimental to the torque tool performance and safety.

5.1.7 Endurance test

All torque tools to be tested shall be cycled at the maximum value, or nominal pre-set torque value for tools of Type II (Classes B and E), for 5 000 cycles in each direction that the mechanism operates, at a rate between 5 cycles/min and 20 cycles/min.

ISO 6789-1:2017(E)

After the endurance test, the torque tool shall still be within the maximum permissible relative deviation specified in 5.1.5 and shall show no physical damage that can be detrimental to the torque tool performance and safety.

5.1.8 Effect of geometric changes

NOTE Some tools indicate or operate at the same torque value independent of the position of the load application point. Some tools indicate or operate at different torque values depending on the position of the load application.

All torque tools to be tested shall be tested for the influence on torque output due to changing geometry, such as but not exclusively flexible head ratchets (see Figure 1) and extension bars designed to be used to reduce operator effort (see Figure 2). The manufacturer shall communicate these influences to users through instruction sheets or the declaration of conformance.

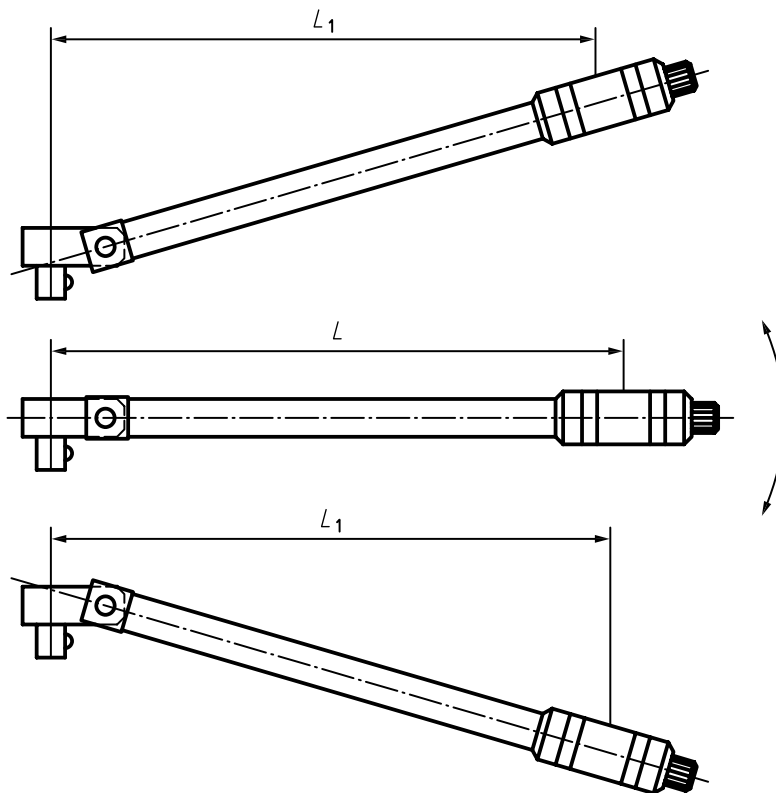

Key

L length

L_1 length reduced

Figure 1 — Example of a flexible head torque wrench

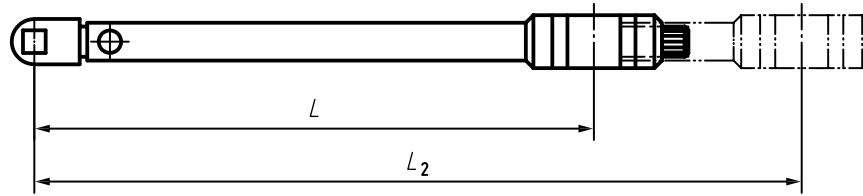

Key

L length

L_2 length extended

Figure 2 — Example of an extension bar

5.2 Quality conformance testing

All torque tools shall be tested during manufacture in accordance with [Clause 6](#).

All torque tools that conform with the requirements in [5.1.5](#) shall either be issued with a declaration of conformance in accordance with [Clause 8](#) or a calibration certificate in accordance with ISO 6789-2.

5.3 Conformance test during use

If the user utilizes procedures for the control of test devices, torque tools shall be included in these procedures. The interval between conformance tests shall be chosen on the basis of the factors of operation such as required maximum permissible deviation, frequency of use, typical load during operation as well as ambient conditions during operation and storage conditions. The interval shall be adapted according to the procedures specified for the control of test devices and by evaluating the results gained during successive conformance tests.

If the user does not utilize a control procedure, a period of 12 months, or 5 000 cycles, whichever occurs first, may be taken as default values for the interval between conformance tests. The interval starts with the first use of the torque tool.

A shorter interval between conformance tests may be used if required by the user, their customer or by legislation.

The torque tool shall be tested for conformance in accordance with [5.2](#) when it has been subjected to an overload greater than the values given in [5.1.6](#), after repair or after any improper handling which might influence the torque tool performance and the fulfilment of the quality conformance requirements.

Conformance tests during use shall be performed in accordance with [5.2](#). The user may define a different specified torque range for the torque tool.

6 Torque measurement

6.1 Torque measurement system

The torque measurement system shall be chosen to be suitable for the measurement of the specified range of the torque tool.

The maximum measurement error of the torque measurement device shall not exceed 1/4 of the claimed maximum permissible relative deviation of the torque tool at each target value.

The torque measurement device shall have a valid calibration certificate traceable to a national standard or to a calibration laboratory meeting the requirements of ISO/IEC 17025. Alternatively, the torque measurement device shall be calibrated by a laboratory maintaining the national measurement standard or according to ISO 6789-2:2017, Annex C.

ISO 6789-1:2017(E)

6.2 Application of torque

6.2.1 The torque shall be applied by means of one of the following methods.

- a) The torque tool is caused to rotate about the torque measurement device axis by the following:
 - 1) for torque wrenches, a force or two forces with equal value and opposite direction for T-handles, applied to the handle of the tool at a constant radial distance;
 - 2) for torque screwdrivers, a torque applied to the handle of the tool or two forces with equal value and opposite direction for T-handles.
- b) The torque measurement device rotates on its measuring axis while a reaction force is applied to the handle of the torque tool.

In all cases, each force applied to the tool shall be perpendicular to the axis of rotation.

In all cases, the handle of the tool shall be allowed to move in all planes of rotation.

The connection between torque measurement system and torque tool shall permit self-alignment so that parasitic forces and moments are minimized.

6.2.2 The tool to be measured shall be oriented in accordance with [Figures 3, 4 or 5](#).

- a) In the case of [Figures 3 or 4](#), the operating force, F , shall be applied within the angular deviation limits specified in the centre of the hand hold position of the grip or of the marked load point.
- b) In the case of [Figure 5](#), the operating torque shall be applied within the angular deviation limits specified.
- c) Tools with flexible head shall be measured with the axis of rotation perpendicular to the axis of the tool.

6.2.3 Indicating torque tools (Type I) shall be loaded with an increasing torque until the target torque value is indicated on the torque tool. If the torque to be measured has been exceeded, then the measurement shall be repeated from the zero position. The time intervals between any two subsequent loadings shall be of the same duration. Slave pointers (memory indicators) shall not be used when taking the readings.

6.2.4 Setting torque tools (Type II) shall be loaded with a slowly and steadily increasing torque until attainment of the target torque is signalled by the torque tool. The target torque shall be reached after a minimum time as defined in [Table 5](#).

Table 5 — Minimum time period for application of torque values

Applied torque value	<10 N·m	≥10 N·m <100 N·m	≥100 N·m <1 000 N·m	≥1 000 N·m
Minimum time to increase the torque from 80 % of target value to target value	0,5 s	1 s	1,5 s	2 s

For screwdrivers (Type II, Classes D, E and F), the time to increase the torque from 80 % of target value to target value shall be between 0,5 s and 1,0 s.

6.3 Ambient conditions

The measurement procedure shall be carried out at an ambient temperature held constant to within ± 1 K. This temperature shall be between 18 °C and 28 °C at a maximum relative humidity of 90 % and shall be documented.

6.4 Measurement requirements

- a) Prior to measurement, the torque measurement device and the torque tool shall be allowed to attain the ambient temperature.
- b) Where the output drive is not permanently attached, the dimensions of the drive that affect the radial distance shall be recorded.

During measurement, analogue scales or dials shall be read in a perpendicular direction in order to minimize parallax errors.

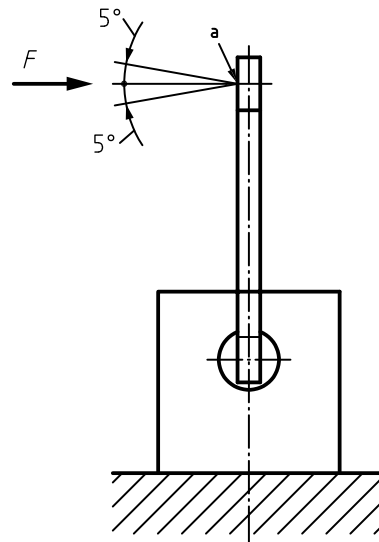

a) Wrench in a vertical position

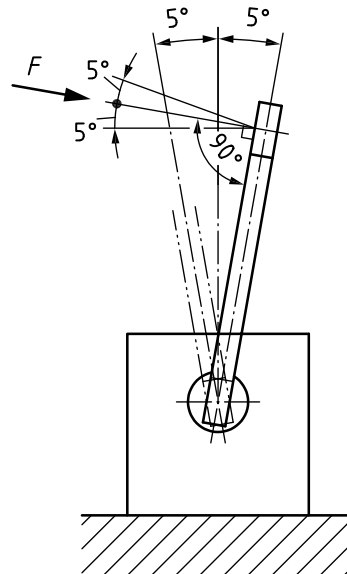

b) Wrench in 5° offset

Key

- a Line contact, marked loading point or centre of the hand hold position of the grip.

Figure 3 — Testing of a wrench in a vertical position (front view)

ISO 6789-1:2017(E)

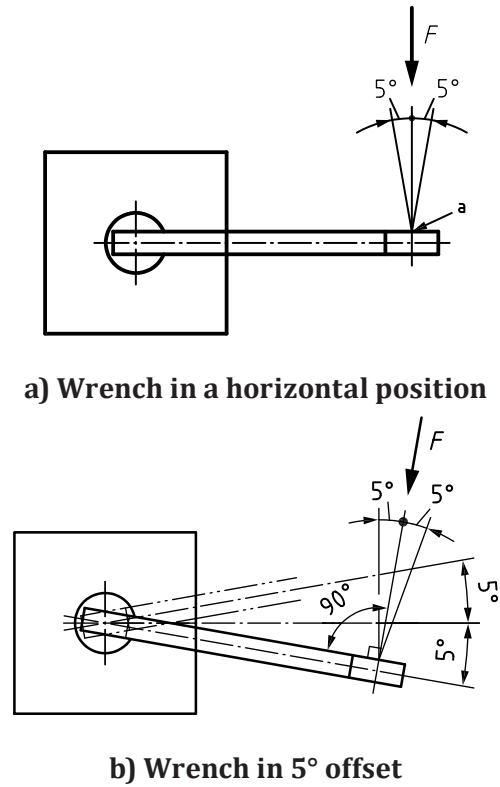

Key

- a Line contact, marked loading point or centre of the hand hold position of the grip.

Figure 4 — Testing of a wrench in a horizontal position (top view)

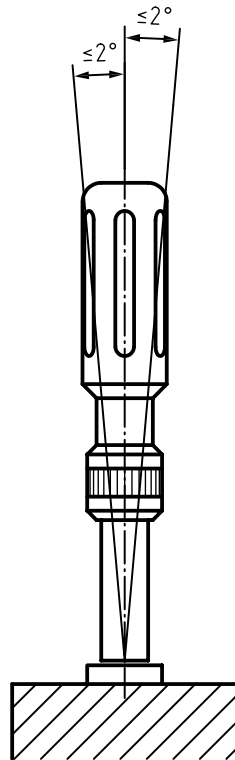

Figure 5 — Testing of a torque screwdriver and T-handle torque wrench in horizontal and vertical positions

6.5 Measurement sequence

6.5.1 General

Where the torque measurement device has not been continuously operating during the previous hour, three loadings to the maximum torque of the torque tool in the measurement direction are required and the torque measurement device shall then be set to zero.

Torque tools with electronic measurement shall be powered during the whole measurement sequence.

The measurement is carried out separately for each direction. For each direction of operation, the torque tool shall be preloaded three times at its maximum specified torque value without recording. The number of recorded measurements shall be according to [Table 6](#).

Table 6 — Number of recorded measurements

Type of torque tool	Type I	Type II	Type II
Class of torque tool	All	A, D and G	B, C, E and F
Number of recorded measurements at each target torque value	5	5	10

Torque tools which are covered by both classifications Type I and Type II shall be measured for both Types, unless the manufacturer has stated a preferred Type for this tool, in which case the maximum permissible relative deviation for the other Type also needs to be stated by the manufacturer.

6.5.2 Indicating torque tools, Type I

Indicating torque tools (Type I, all Classes) shall first be measured at the lowest specified torque value of the measurement range (see [5.1.3](#)) then at approximately 60 % and finally at 100 % of the torque tool's maximum value.

For indicating torque tools (Type I, all Classes), after the three preloadings at the maximum torque of the tool, all load on the torque tool and the torque measurement system shall be removed. After a waiting period of at least 5 s, the pointer or electronic display of the torque tool and the torque measurement device shall be set to zero where such a facility exists. Then, the further number of recorded measurements shall be as specified in [Table 6](#).

For indicating torque tools (Type I) with electronic display, the readings shall only be recorded after the display has stabilized.

6.5.3 Setting torque tools, Type II

Setting torque tools (Type II, Classes A, D and G) shall first be measured at the lowest specified torque value of the measurement range (see [5.1.3](#)) then at approximately 60 % and finally at 100 % of the torque tool's maximum value.

For setting torque tools (Type II, all Classes), after the three preloadings at the maximum torque of the tool, all load on the torque tool and the torque measurement system shall be removed. After a waiting period of at least 5 s, the pointer or electronic display of the torque measurement device shall be set to zero where such a facility exists. Then, the further number of recorded measurements shall be as specified in [Table 6](#).

Setting torque tools (Type II, Classes A, D and G) shall be set to each target value starting from a lower value. If the target value is exceeded, the tool shall be set back to a lower value before re-adjustment to the target value.

Setting torque tools (Type II, Classes C and F) shall be measured 10 times in succession at the lowest limit value or nominal torque pre-set value.

ISO 6789-1:2017(E)

Setting torque tools (Type II, Classes B and E) shall be measured 10 times in succession at the nominal fixed value.

7 Calculation of deviation

7.1 General

The evaluation of the relative measurement deviation shall be made by [Formula \(1\)](#).

$$a_d = \frac{(X_o - X_t)}{X_t} \times 100 \quad (1)$$

where

- a_d is the calculated relative deviation of the torque tool in per cent (%) for the target torque;
- X_t is for indicating tools torque tools Type I the indicated value;
- X_t is for setting torque tools Type II (Classes A, D and G), the torque value set on scale or display;
- X_t is for setting torque tools Type II (Classes B and E), the nominal torque value set;
- X_t is for setting torque tools Type II (Classes C and F), the lowest limit value or nominal torque pre-set value in accordance with [6.5](#);
- X_o is the value observed by the torque measurement device.

7.2 Calculation example 1

Calculation of the relative deviation of indicating torque tools (Type I) and setting torque tools [Type II, except Type II (Class B, C, E and F)]:

- indicated value of dial, mechanical scale or display [indicating torque tool, Type I (Classes A, B, C, D and E)], or
- set value of mechanical scale or display [setting torque tool, Type II (Classes A, D and G)], or
- nominal value [setting torque tool, Type II (Classes A, D and G)]:

$$X_t = 100 \text{ N}\cdot\text{m}$$

- observed values (determined by the torque measurement device):

$$X_{o1} = 104,0 \text{ N}\cdot\text{m}$$

$$X_{o2} = 96,5 \text{ N}\cdot\text{m}$$

$$X_{o3} = 102,6 \text{ N}\cdot\text{m}$$

$$X_{o4} = 99,0 \text{ N}\cdot\text{m}$$

$$X_{o5} = 101,0 \text{ N}\cdot\text{m}$$

- calculated relative deviations of the torque tool in %; see [Formula \(1\)](#):

$$a_{d1} = \frac{(104,0 - 100)}{100} \times 100 = +4,0$$

$$a_{d2} = \frac{(96,5 - 100)}{100} \times 100 = -3,5$$

$$a_{d3} = \frac{(102,6 - 100)}{100} \times 100 = +2,6$$

$$a_{d4} = \frac{(99 - 100)}{100} \times 100 = -1,0$$

$$a_{d5} = \frac{(101 - 100)}{100} \times 100 = +1,0$$

7.3 Calculation example 2

Calculation of the relative deviation of setting torque tools, adjustable, non-graduated [Type II (Class B, C, E and F)]:

- nominal value set [setting torque tool, Type II (Classes B and E)] or
- lowest specified torque value or pre-set value [setting torque tool, Type II (Classes C and F)]:

$$X_t = 100 \text{ N}\cdot\text{m}$$

- observed values (determined by the torque measurement device):

$$X_{o1} = 104,0 \text{ N}\cdot\text{m}$$

$$X_{o2} = 103,0 \text{ N}\cdot\text{m}$$

$$X_{o3} = 102,8 \text{ N}\cdot\text{m}$$

$$X_{o4} = 102,0 \text{ N}\cdot\text{m}$$

$$X_{o5} = 101,0 \text{ N}\cdot\text{m}$$

$$X_{o6} = 101,2 \text{ N}\cdot\text{m}$$

$$X_{o7} = 101,7 \text{ N}\cdot\text{m}$$

$$X_{o8} = 101,9 \text{ N}\cdot\text{m}$$

$$X_{o9} = 102,2 \text{ N}\cdot\text{m}$$

$$X_{o10} = 102,5 \text{ N}\cdot\text{m}$$

- calculated relative deviations of the torque tools in %:

$$a_{d1} = \frac{(104,0 - 100) \times 100}{100} = +4,0$$

ISO 6789-1:2017(E)

$$a_{d2} = \frac{(103,0 - 100) \times 100}{100} = +3,0$$

$$a_{d3} = \frac{(102,8 - 100) \times 100}{100} = +2,8$$

$$a_{d4} = \frac{(102,0 - 100) \times 100}{100} = +2,0$$

$$a_{d5} = \frac{(101,0 - 100) \times 100}{100} = +1,0$$

$$a_{d6} = \frac{(101,2 - 100) \times 100}{100} = +1,2$$

$$a_{d7} = \frac{(101,7 - 100,0) \times 100}{100,0} = +1,7$$

$$a_{d8} = \frac{(101,9 - 100) \times 100}{100} = +1,9$$

$$a_{d9} = \frac{(102,2 - 100) \times 100}{100} = +2,2$$

$$a_{d10} = \frac{(102,5 - 100) \times 100}{100} = +2,5$$

8 Declaration of conformance

The declaration of conformance shall contain at least the following information:

- a) statement that it is a declaration of conformance in accordance with this document;
- b) identification (type and serial number) of the torque tool;
- c) where an interchangeable element has been used with the tool, the effective length or dimension of that interchangeable element shall be recorded;
- d) where an extension handle has been used with the torque tool, it shall be recorded;
- e) specified torque range or fixed torque value of the torque tool;
- f) identification (type and serial number) of the torque measurement device;
- g) direction(s) of operation;
- h) ambient temperature and statement on humidity;
- i) date of the measurement;
- j) name of the responsible person;
- k) maximum permissible relative deviation according to [5.1.5](#);
- l) observed values at each target torque (see [6.5](#));
- m) statement whether or not the observed values fall within the maximum permissible relative deviation as defined in list item k);

- n) maximum measurement error and measurement uncertainty interval of the torque measurement device;
- o) statement that the measurement error of the torque measurement device is less than 1/4 of the maximum permissible relative deviation of the torque tool;
- p) for tools with flexible head, a statement that the result is valid only if the measuring axis is perpendicular to the axis of the tool.

9 Marking

During manufacture, hand torque tools shall be marked, permanently and legibly, at least with the following information:

- a) the maximum and minimum torque values or [for Type II (Classes B and E)] the fixed adjusted torque value;
- b) the unit(s) of torque;
- c) Type II (Classes C and F) may also be marked in a non-permanent way with the nominal torque pre-set value in user specified units;
- d) the direction of operation (for tools capable of operating in one direction only);
- e) the force loading point [except Type I (Classes D and E) and Type II (Classes D, E and F)];
- f) the name or trademark of the manufacturer or responsible supplier;
- g) where accompanied by a declaration of conformance, the torque tool shall have a serial or identification number. If necessary, an identification number shall be assigned.

Annex A (normative)

Examples of indicating torque tools (Type I)

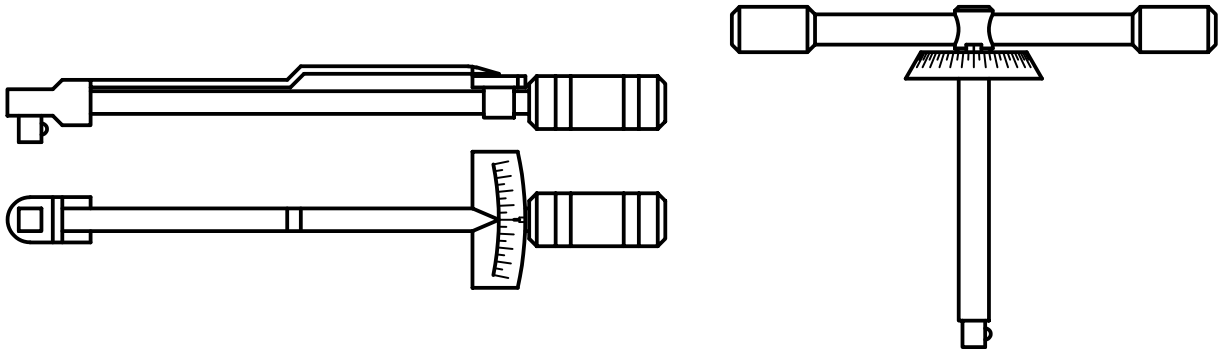

Figure A.1 — Class A: wrench, torsion or flexion bar

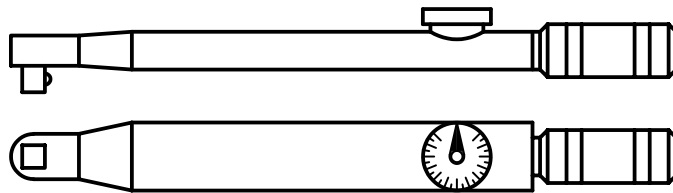

Figure A.2 — Class B: wrench, rigid housing, with scale or dial or display

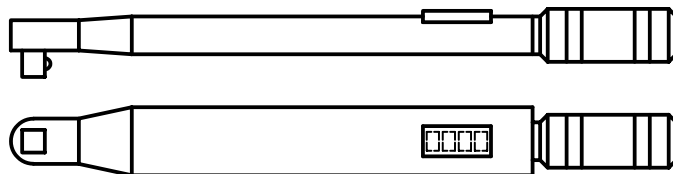

Figure A.3 — Class C: wrench, rigid housing and electronic measurement

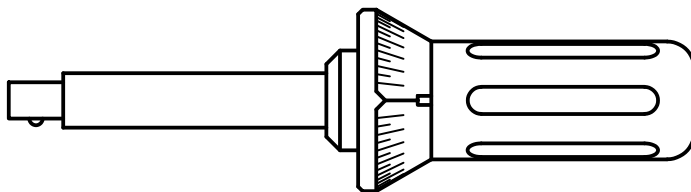

Figure A.4 — Class D: screwdriver, with scale or dial or display

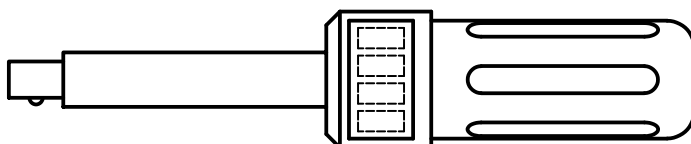

Figure A.5 — Class E: screwdriver, with electronic measurement

Annex B (normative)

Examples of setting torque tools (Type II)

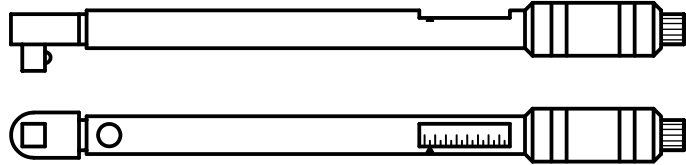

Figure B.1 — Class A: wrench, adjustable, graduated or with display

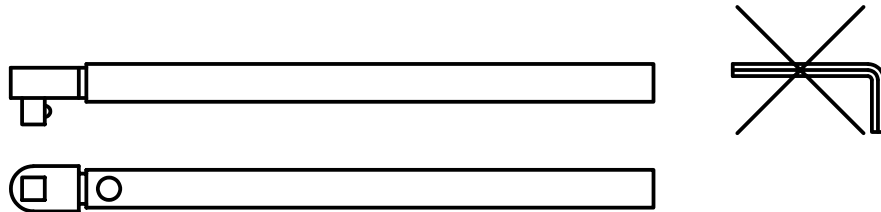

Figure B.2 — Class B: wrench fixed adjustment

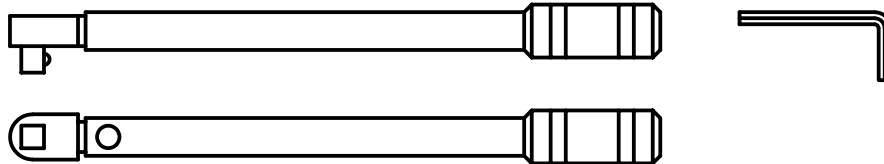

Figure B.3 — Class C: wrench, adjustable, non-graduated

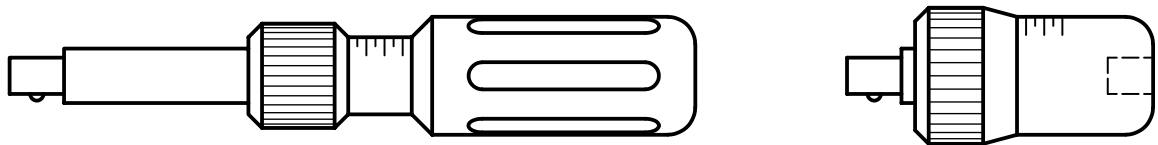

Figure B.4 — Class D: screwdriver, adjustable, graduated or with display

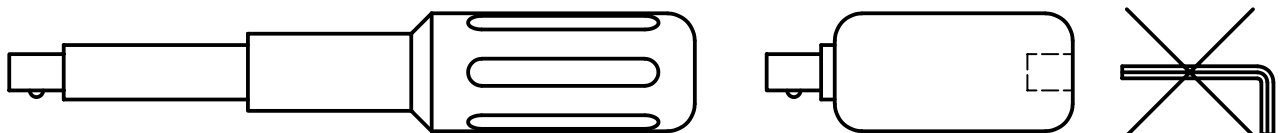

Figure B.5 — Class E: screwdriver, fixed adjustment

ISO 6789-1:2017(E)

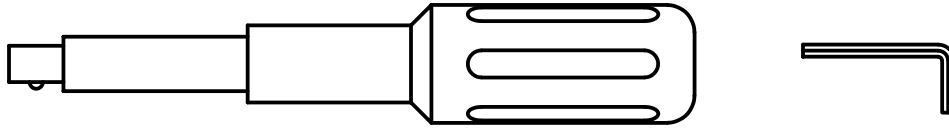

Figure B.6 — Class F: screwdriver, adjustable, non-graduated

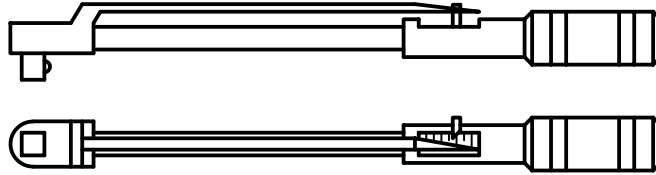
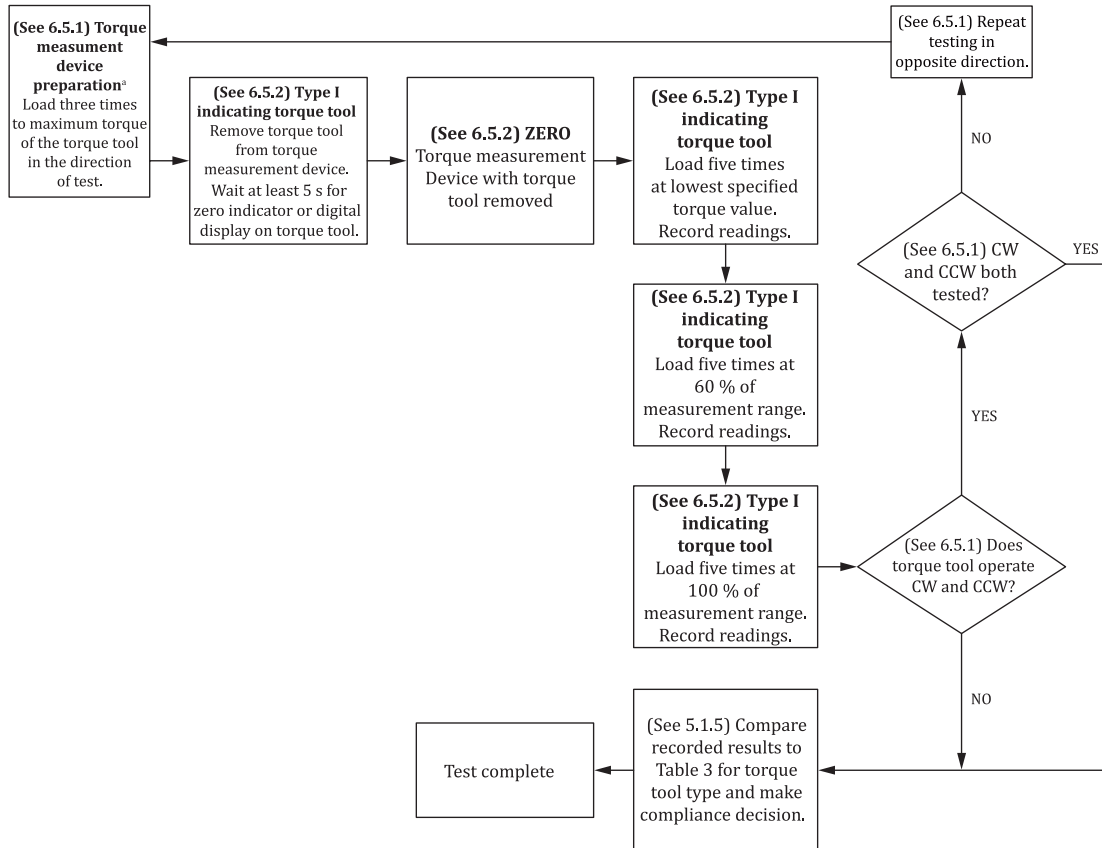

Figure B.7 — Class G: wrench flexion bar, adjustable, graduated

Annex C (informative)

Measurement sequence flowchart for torque tools

C.1 Indicating torque tools (Type I)



Key

CW clockwise direction

CCW counter-clockwise direction

^a Torque measurement device and torque tool shall be allowed to attain the ambient temperature prior to measurement.

ISO 6789-1:2017(E)

C.2 Setting Torque tools [Type II (Classes A, D and G)]

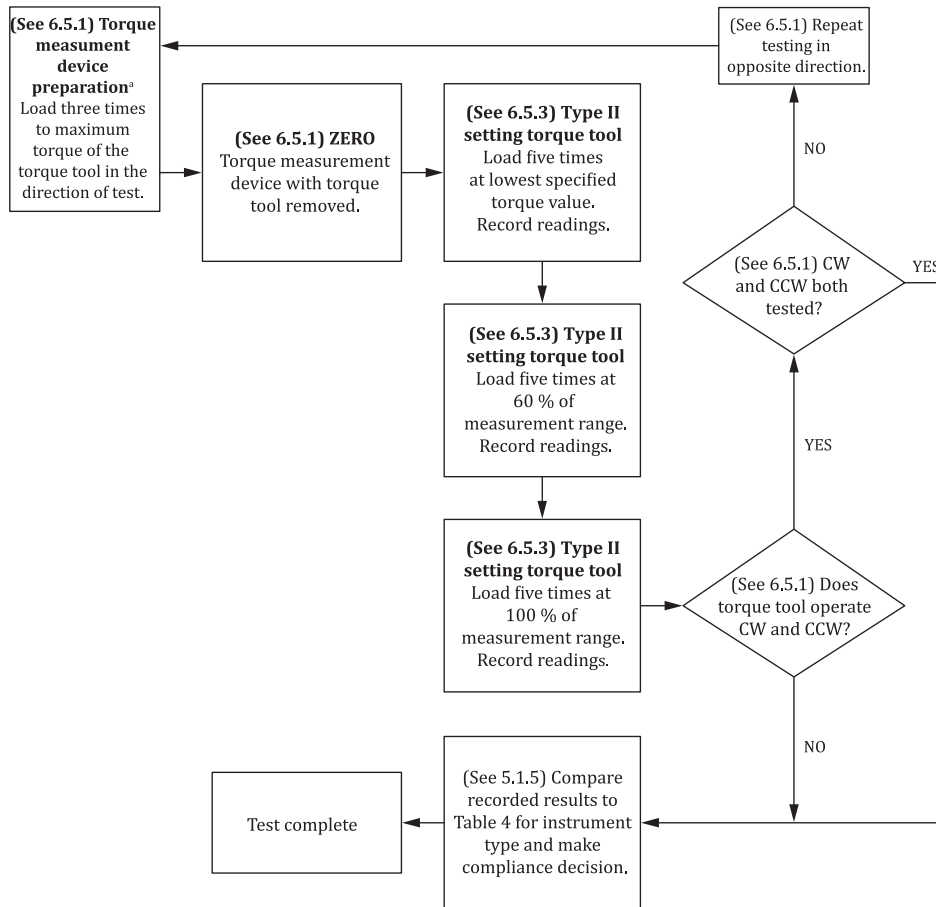

Key

CW clockwise direction

CCW counter-clockwise direction

^a Torque measurement device and torque tool shall be allowed to attain the ambient temperature prior to measurement.

C.3 Setting torque tools [Type II (Classes B, C, E and F)]

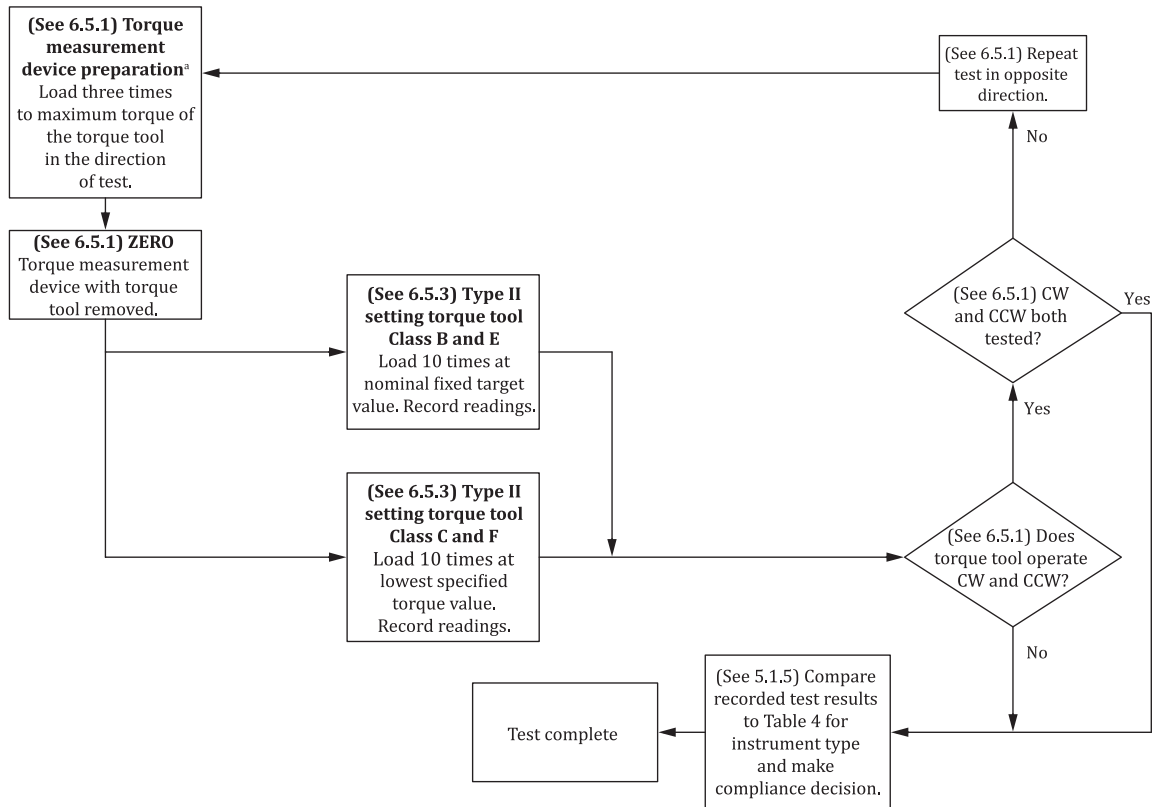

Key

CW clockwise direction

CCW counter-clockwise direction

^a Torque measurement device and torque tool shall be allowed to attain the ambient temperature prior to measurement.

Bibliography

- [1] ISO 1703:2005, *Assembly tools for screws and nuts — Designation and nomenclature*
- [2] ISO 9001, *Quality management systems — Requirements*
- [3] ISO/IEC Guide 99, *International vocabulary of metrology — Basic and general concepts and associated terms (VIM)*
- [4] ISO/IEC Guide 98-3, *Uncertainty of measurement — Part 3: Guide to the expression of uncertainty in measurement (GUM:1995)*

ISO 6789-1:2017(E)

ICS 25.140.30

Price based on 22 pages