

AW139

GAM/MBR/21/22/72-02

REVISION 0

MASS AND BALANCE REPORT

IMPORTANT NOTE

This report contains of Mass and Center of Gravity Schedule (MCGS), Weighing Record (WR), Equipment list and Aircraft Basic Mass and Balance Record.

This report shall be approved by qualified Weighing Engineer (WE) on MCGS and/or WR.

This Mass and Balance Report is approved under GAM privilege and can be used for flight operation.

The superseded report shall be removed from the flight manual prior to insert the latest Mass and Balance report.

The Mass and Balance report supersedes all earlier issues.

The effectivity of the report at the latest revision is specified on the Record of Revisions.

| | |
|--------------|---------------------|
| Doc. ref. no | GAM/MBR/21/22/72-02 |
| Rev. Date | 24/12/2021 |
| Rev. No | 0 |

TABLE OF CONTENTS

RECORD OF REVISIONS..... 3

SECTION 1 – MASS AND CENTRE OF GRAVITY SCHEDULE (MCGS) 4

 CENTRE OF GRAVITY LIMITATIONS..... 4

 DATUM REFERENCES..... 4

 PART A – BASIC WEIGHT 4

 PART B – VARIABLE LOAD..... 5

 PART C – LOADING INFORMATION (DISPOSABLE LOAD) 6

SECTION 2- MASS AND BALANCE RECORD 34

 PART 2A – WEIGHING RECORD (WR) 34

 PART 2B – EQUIPMENT LIST 40

APPENDIX – AIRCRAFT BASIC MASS AND BALANCE RECORD i

| | |
|--------------|---------------------|
| Doc. ref. no | GAM/MBR/21/22/72-02 |
| Rev. Date | 24/12/2021 |
| Rev. No | 0 |

SECTION 1 – MASS AND CENTRE OF GRAVITY SCHEDULE (MCGS)

| | |
|--|------------------|
| Aircraft designation | : AW139 |
| Nationality | : Malaysia |
| Registration number | : M72-02 |
| Aircraft manufacturer/constructor | : Leonardo S.p.A |
| Aircraft serial number | : 31315 |
| Weight limitations – maximum authorised weight in flight | : 6,400 kg |

CENTRE OF GRAVITY LIMITATIONS

For Longitudinal Forward and Aft CG Limit at various gross weight, refer RFM Document N^o 139G0290X002; Figure 1-1 Weight and Longitudinal CG Limitations.

For Lateral LH and RH Limit and Aft CG Limit at various gross weight, refer RFM Document N^o 139G0290X002; Figure 1-2 Weight and Lateral CG Limitations.

DATUM REFERENCES

Longitudinal datum line (Station 0) is located 3160 mm forward of the front jack point.

Lateral datum is the aircraft symmetry plane.

PART A – BASIC WEIGHT

| | |
|---|----------------------------------|
| The Basic Weight of the aircraft as calculated in Section 2 is | : 4495.00 kg |
| The aircraft was weighed on (date) | : 27/04/2020 |
| The C.G of the aircraft in the same condition at this weight is | : LONGITUDINAL 5379.50 mm |
| | : LATERAL 8.56 mm |
| The total moment about the datum in this condition is | : LONGITUDINAL 24180866.00 kg.mm |
| | : LATERAL 38462.50 kg.mm |
| The Basic Weight includes the weight of the total quantity of unusable fuel, oil & fluids in the normal condition and the list of equipment as specified in Section 2 – Basic Equipment List. | |

| | |
|--------------|---------------------|
| Doc. ref. no | GAM/MBR/21/22/72-02 |
| Rev. Date | 24/12/2021 |
| Rev. No | 0 |

PART B – VARIABLE LOAD

The Weights, Lever Arms (Measured Forward or Aft of the Datum defined in Part A) of the Variable Load, which includes the weight of the crew and those items of the equipment including usable fluids other than fuel, which do not form part of the Basic Equipment are shown below:

The Variable Load depends upon the equipment carried for the particular role.

| ITEM | DESCRIPTION | WEIGHT (KG) | ARM (MM) | | MOMENT (KG.MM) | |
|------|-------------|----------------|-------------|---------|-------------------|------|
| | | | LONG. | LAT. | LONG. | LAT. |
| 1 | Pilot | +Actual | 2820.00 | 550.00 | | |
| 2 | Co-Pilot | +Actual | 2820.00 | -550.00 | | |

| | |
|--------------|---------------------|
| Doc. ref. no | GAM/MBR/21/22/72-02 |
| Rev. Date | 24/12/2021 |
| Rev. No | 0 |

PART C – LOADING INFORMATION (DISPOSABLE LOAD)

It is a requirement of the MCAR that the pilot-in-command satisfies himself before take-off that the load is of such mass, and is so distributed and secured, that it may safely be carried on the intended flight.

Information below is given to enable Disposable Load (Fuel and Pay-Load) to be distributed so that the Maximum Weight and Centre of Gravity Limitations given in the Flight Manual are NOT exceeded.

The appropriate Lever Arms of the Disposable Loads are:-

| ITEM | MISCELLANEOUS LOADING DATA | ARM (MM) | |
|------|--|----------|------|
| | | LONG. | LAT. |
| 1 | <p><u>FUEL IN TANKS</u></p> <p><u>MAIN TANKS</u></p> <p>Total Usable 1270 kg/1588 litres</p> <p>Unusable..... 16 kg/20 litres</p> <p><u>AUXILIARY TANKS</u></p> <p>Auxiliary Tank Usable..... 400 kg/500 litres</p> <p>Total Usable (Main Plus Auxiliary Tanks)..... 1670 kg/2088 litres</p> <p>Unusable..... No change</p> <p>Maximum Total Usable Capacity of fuel tanks (Main Plus Auxiliary Tanks) is 2088 Litre.</p> <p>Weight of this quantity of fuel at 0.8 kg / litre is 1670 kg.</p> | 6233.00 | 0.00 |
| | | 6240.00 | 0.00 |

| ITEM | MISCELLANEOUS LOADING DATA (IF REQUIRED) | MAXIMUM WEIGHT (KG) | ARM (MM) | |
|------|---|---------------------|----------|---------|
| | | | LONG. | LATERAL |
| 2 | <p><u>CABIN FLOOR LOADING</u></p> <p>On left hand forward cabin floor</p> <p>Maximum distributed load..... 1000 kg (2204.62 lb)</p> | 1000 | 4507.5 | 0.00 |
| 3 | <p><u>BAGGAGE COMPARTMENT LOADING</u></p> <p>Cargo compartment</p> <p>Maximum Load..... 200 kg/m² (61 lb/sq.ft)</p> | 200 | 7700.00 | 0.00 |

| | |
|--------------|---------------------|
| Doc. ref. no | GAM/MBR/21/22/72-02 |
| Rev. Date | 24/12/2021 |
| Rev. No | 0 |

4 PASSENGER SEAT CONFIGURATION

4.1. 15 SEATER (KIT FISHER PASSENGER SEAT OFFSHORE 15)

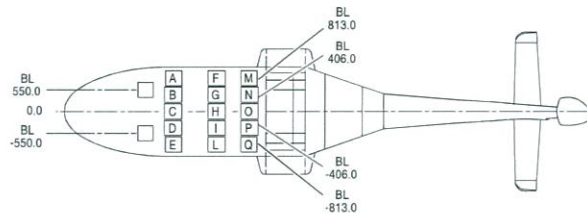
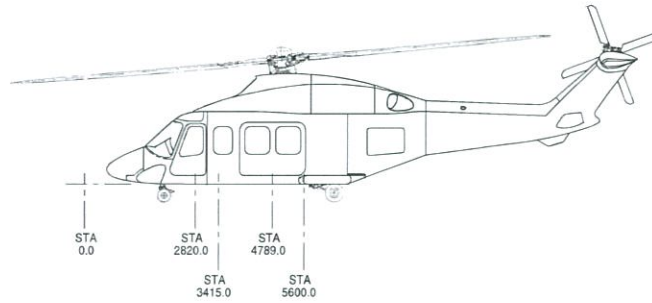

| NO. | ITEM | WEIGHT (KG) | ARM (MM) | |
|-----|-------------|-------------|----------|---------|
| | | | LONG. | LAT. |
| 1. | Passenger A | +Actual | 3449.00 | 813.00 |
| 2. | Passenger B | +Actual | 3415.00 | 406.00 |
| 3. | Passenger C | +Actual | 3415.00 | 0.00 |
| 4. | Passenger D | +Actual | 3415.00 | -406.00 |
| 5. | Passenger E | +Actual | 3449.00 | -813.00 |
| 6. | Passenger F | +Actual | 4789.00 | 813.00 |
| 7. | Passenger G | +Actual | 4789.00 | 406.00 |
| 8. | Passenger H | +Actual | 4789.00 | 0.00 |
| 9. | Passenger I | +Actual | 4789.00 | -406.00 |
| 10. | Passenger L | +Actual | 4789.00 | -813.00 |
| 11. | Passenger M | +Actual | 5556.00 | 813.00 |
| 12. | Passenger N | +Actual | 5600.00 | 406.00 |
| 13. | Passenger O | +Actual | 5600.00 | 0.00 |
| 14. | Passenger P | +Actual | 5600.00 | -406.00 |
| 15. | Passenger Q | +Actual | 5556.00 | -813.00 |

| | |
|--------------|---------------------|
| Doc. ref. no | GAM/MBR/21/22/72-02 |
| Rev. Date | 24/12/2021 |
| Rev. No | 0 |

4.2. 15 SEATER

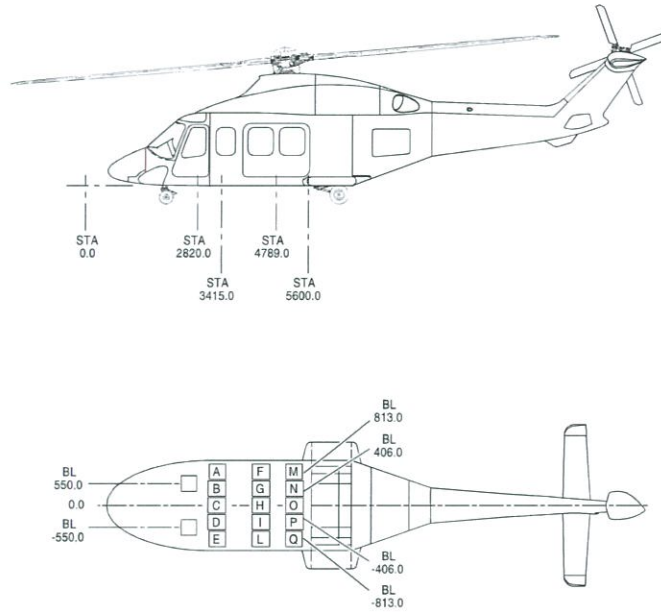

| NO. | ITEM | WEIGHT (KG) | ARM (MM) | |
|-----|-------------|-------------|----------|---------|
| | | | LONG. | LAT. |
| 1. | Passenger A | +Actual | 3449.00 | 813.00 |
| 2. | Passenger B | +Actual | 3415.00 | 406.00 |
| 3. | Passenger C | +Actual | 3415.00 | 0.00 |
| 4. | Passenger D | +Actual | 3415.00 | -406.00 |
| 5. | Passenger E | +Actual | 3449.00 | -813.00 |
| 6. | Passenger F | +Actual | 4789.00 | 813.00 |
| 7. | Passenger G | +Actual | 4789.00 | 406.00 |
| 8. | Passenger H | +Actual | 4789.00 | 0.00 |
| 9. | Passenger I | +Actual | 4789.00 | -406.00 |
| 10. | Passenger L | +Actual | 4789.00 | -813.00 |
| 11. | Passenger M | +Actual | 5556.00 | 813.00 |
| 12. | Passenger N | +Actual | 5600.00 | 406.00 |
| 13. | Passenger O | +Actual | 5600.00 | 0.00 |
| 14. | Passenger P | +Actual | 5600.00 | -406.00 |
| 15. | Passenger Q | +Actual | 5556.00 | -813.00 |

| | |
|--------------|---------------------|
| Doc. ref. no | GAM/MBR/21/22/72-02 |
| Rev. Date | 24/12/2021 |
| Rev. No | 0 |

4.3. 14 SEATER (KIT FISHER PASSENGER SEAT OFFSHORE 14)

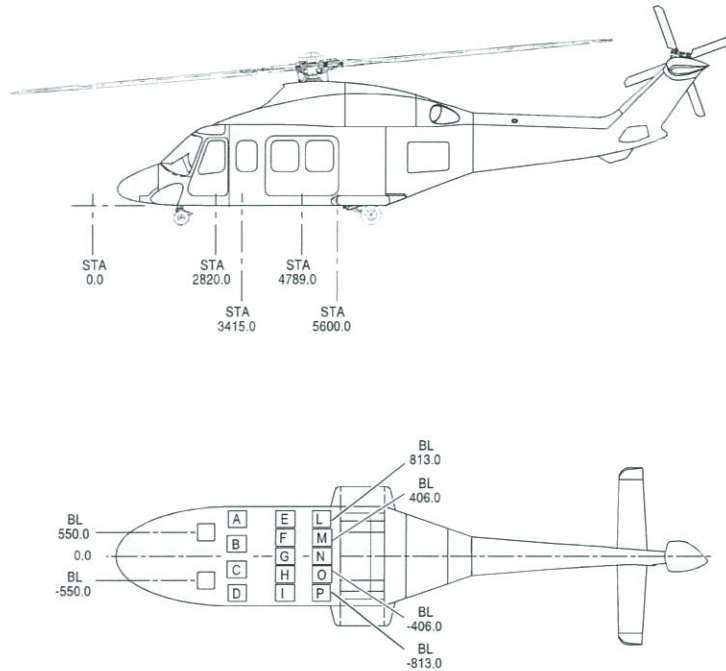

| NO. | ITEM | WEIGHT (KG) | ARM (MM) | |
|-----|-------------|-------------|----------|---------|
| | | | LONG. | LAT. |
| 1. | Passenger A | +Actual | 3415.00 | 737.00 |
| 2. | Passenger B | +Actual | 3415.00 | 254.00 |
| 3. | Passenger C | +Actual | 3415.00 | -254.00 |
| 4. | Passenger D | +Actual | 3415.00 | -737.00 |
| 5. | Passenger E | +Actual | 4789.00 | 813.00 |
| 6. | Passenger F | +Actual | 4789.00 | 406.00 |
| 7. | Passenger G | +Actual | 4789.00 | 0.00 |
| 8. | Passenger H | +Actual | 4789.00 | -406.00 |
| 9. | Passenger I | +Actual | 4789.00 | -813.00 |
| 10. | Passenger L | +Actual | 5556.00 | 813.00 |
| 11. | Passenger M | +Actual | 5600.00 | 406.00 |
| 12. | Passenger N | +Actual | 5600.00 | 0.00 |
| 13. | Passenger O | +Actual | 5600.00 | -406.00 |
| 14. | Passenger P | +Actual | 5556.00 | -813.00 |

| | |
|--------------|---------------------|
| Doc. ref. no | GAM/MBR/21/22/72-02 |
| Rev. Date | 24/12/2021 |
| Rev. No | 0 |

4.4. 14 SEATER

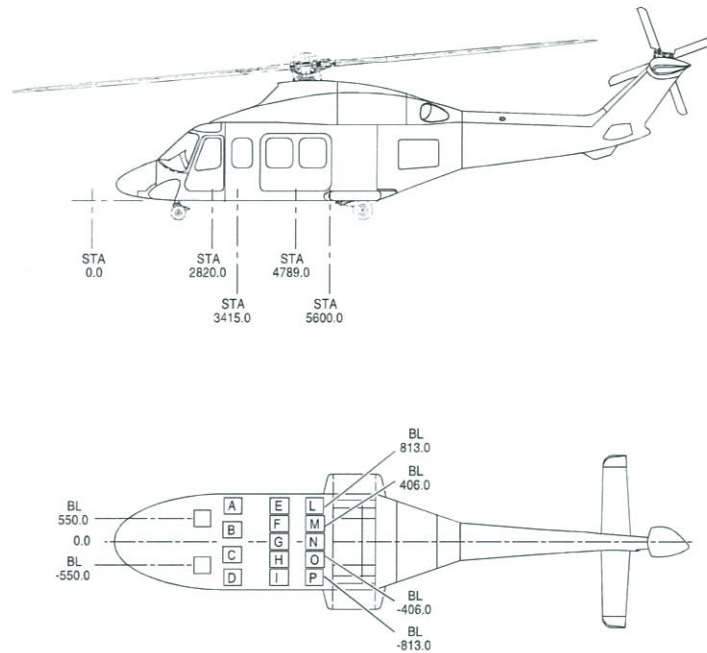

| NO. | ITEM | WEIGHT (KG) | ARM (MM) | |
|-----|-------------|-------------|----------|---------|
| | | | LONG. | LAT. |
| 1. | Passenger A | +Actual | 3415.00 | 737.00 |
| 2. | Passenger B | +Actual | 3415.00 | 254.00 |
| 3. | Passenger C | +Actual | 3415.00 | -254.00 |
| 4. | Passenger D | +Actual | 3415.00 | -737.00 |
| 5. | Passenger E | +Actual | 4789.00 | 813.00 |
| 6. | Passenger F | +Actual | 4789.00 | 406.00 |
| 7. | Passenger G | +Actual | 4789.00 | 0.00 |
| 8. | Passenger H | +Actual | 4789.00 | -406.00 |
| 9. | Passenger I | +Actual | 4789.00 | -813.00 |
| 10. | Passenger L | +Actual | 5556.00 | 813.00 |
| 11. | Passenger M | +Actual | 5600.00 | 406.00 |
| 12. | Passenger N | +Actual | 5600.00 | 0.00 |
| 13. | Passenger O | +Actual | 5600.00 | -406.00 |
| 14. | Passenger P | +Actual | 5556.00 | -813.00 |

| | |
|--------------|---------------------|
| Doc. ref. no | GAM/MBR/21/22/72-02 |
| Rev. Date | 24/12/2021 |
| Rev. No | 0 |

4.5. 13 SEATER

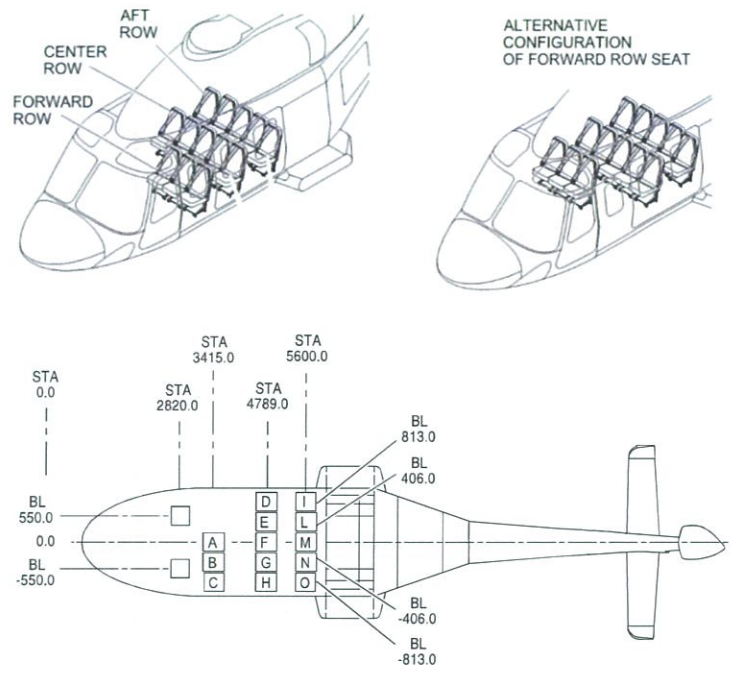

| NO. | ITEM | WEIGHT (KG) | ARM (MM) | |
|-----|-------------|-------------|----------|---------|
| | | | LONG. | LAT. |
| 1. | Passenger A | +Actual | 3415.00 | 0.00 |
| 2. | Passenger B | +Actual | 3415.00 | -406.00 |
| 3. | Passenger C | +Actual | 3415.00 | -813.00 |
| 4. | Passenger D | +Actual | 4789.00 | 813.00 |
| 5. | Passenger E | +Actual | 4789.00 | 406.00 |
| 6. | Passenger F | +Actual | 4789.00 | 0.00 |
| 7. | Passenger G | +Actual | 4789.00 | -406.00 |
| 8. | Passenger H | +Actual | 4789.00 | -813.00 |
| 9. | Passenger I | +Actual | 5556.00 | 813.00 |
| 10. | Passenger L | +Actual | 5600.00 | 406.00 |
| 11. | Passenger M | +Actual | 5600.00 | 0.00 |
| 12. | Passenger N | +Actual | 5600.00 | -406.00 |
| 13. | Passenger O | +Actual | 5556.00 | -813.00 |

| | |
|--------------|---------------------|
| Doc. ref. no | GAM/MBR/21/22/72-02 |
| Rev. Date | 24/12/2021 |
| Rev. No | 0 |

4.6. 13 SEATER

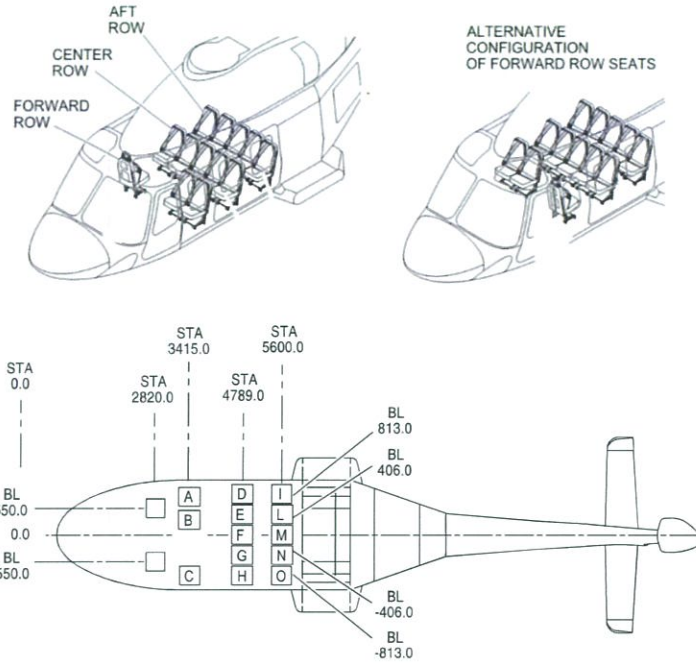

| NO. | ITEM | WEIGHT (KG) | ARM (MM) | |
|-----|-------------|-------------|----------|---------|
| | | | LONG. | LAT. |
| 1. | Passenger A | +Actual | 3415.00 | 813.00 |
| 2. | Passenger B | +Actual | 3415.00 | 406.00 |
| 3. | Passenger C | +Actual | 3415.00 | -813.00 |
| 4. | Passenger D | +Actual | 4789.00 | 813.00 |
| 5. | Passenger E | +Actual | 4789.00 | 406.00 |
| 6. | Passenger F | +Actual | 4789.00 | 0.00 |
| 7. | Passenger G | +Actual | 4789.00 | -406.00 |
| 8. | Passenger H | +Actual | 4789.00 | -813.00 |
| 9. | Passenger I | +Actual | 5556.00 | 813.00 |
| 10. | Passenger L | +Actual | 5600.00 | 406.00 |
| 11. | Passenger M | +Actual | 5600.00 | 0.00 |
| 12. | Passenger N | +Actual | 5600.00 | -406.00 |
| 13. | Passenger O | +Actual | 5556.00 | -813.00 |

| | |
|--------------|---------------------|
| Doc. ref. no | GAM/MBR/21/22/72-02 |
| Rev. Date | 24/12/2021 |
| Rev. No | 0 |

4.7. 12 SEATER

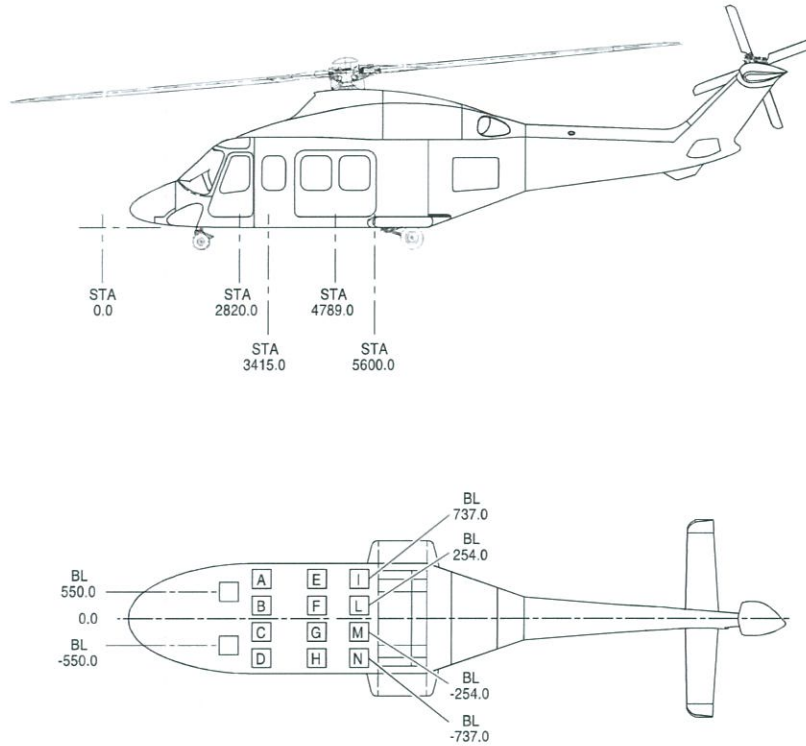

| NO. | ITEM | WEIGHT (KG) | ARM (MM) | |
|-----|-------------|-------------|----------|---------|
| | | | LONG. | LAT. |
| 1. | Passenger A | +Actual | 3415.00 | 737.00 |
| 2. | Passenger B | +Actual | 3415.00 | 254.00 |
| 3. | Passenger C | +Actual | 3415.00 | -254.00 |
| 4. | Passenger D | +Actual | 3415.00 | -737.00 |
| 5. | Passenger E | +Actual | 4789.00 | 737.00 |
| 6. | Passenger F | +Actual | 4789.00 | 254.00 |
| 7. | Passenger G | +Actual | 4789.00 | -254.00 |
| 8. | Passenger H | +Actual | 4789.00 | -737.00 |
| 9. | Passenger I | +Actual | 5600.00 | 737.00 |
| 10. | Passenger L | +Actual | 5600.00 | 254.00 |
| 11. | Passenger M | +Actual | 5600.00 | -254.00 |
| 12. | Passenger N | +Actual | 5600.00 | -737.00 |

| | |
|--------------|---------------------|
| Doc. ref. no | GAM/MBR/21/22/72-02 |
| Rev. Date | 24/12/2021 |
| Rev. No | 0 |

4.8. 11 SEATER

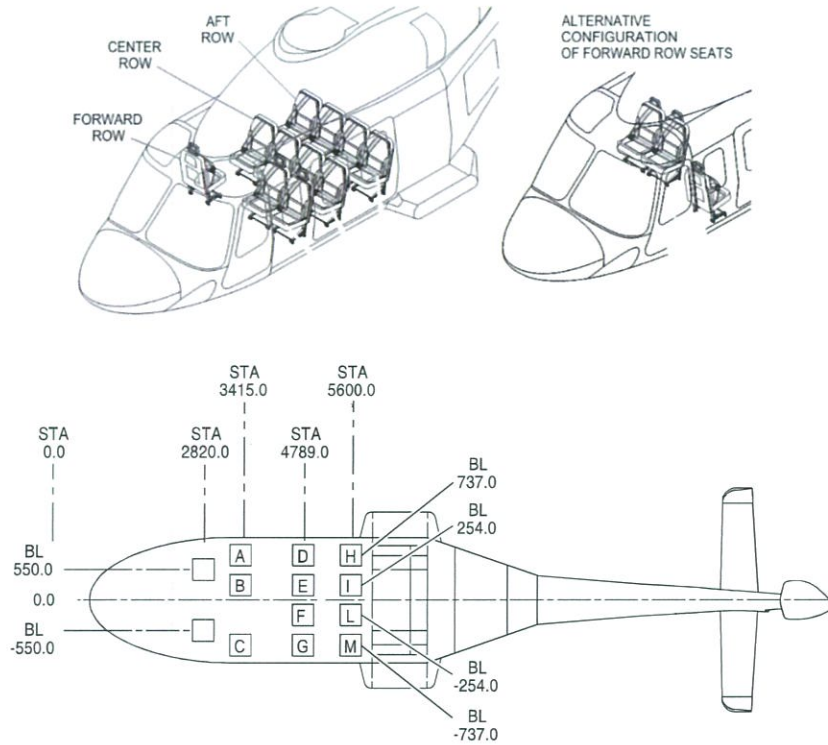

| NO. | ITEM | WEIGHT (KG) | ARM (MM) | |
|-----|-------------|-------------|----------|---------|
| | | | LONG. | LAT. |
| 1. | Passenger A | +Actual | 3145.00 | 737.00 |
| 2. | Passenger B | +Actual | 3145.00 | 254.00 |
| 3. | Passenger C | +Actual | 3145.00 | -737.00 |
| 4. | Passenger D | +Actual | 4789.00 | 737.00 |
| 5. | Passenger E | +Actual | 4789.00 | 254.00 |
| 6. | Passenger F | +Actual | 4789.00 | -254.00 |
| 7. | Passenger G | +Actual | 4789.00 | -737.00 |
| 8. | Passenger H | +Actual | 5600.00 | 737.00 |
| 9. | Passenger I | +Actual | 5600.00 | 254.00 |
| 10. | Passenger L | +Actual | 5600.00 | -254.00 |
| 11. | Passenger M | +Actual | 5600.00 | -737.00 |

| | |
|--------------|---------------------|
| Doc. ref. no | GAM/MBR/21/22/72-02 |
| Rev. Date | 24/12/2021 |
| Rev. No | 0 |

4.9. 10 SEATER

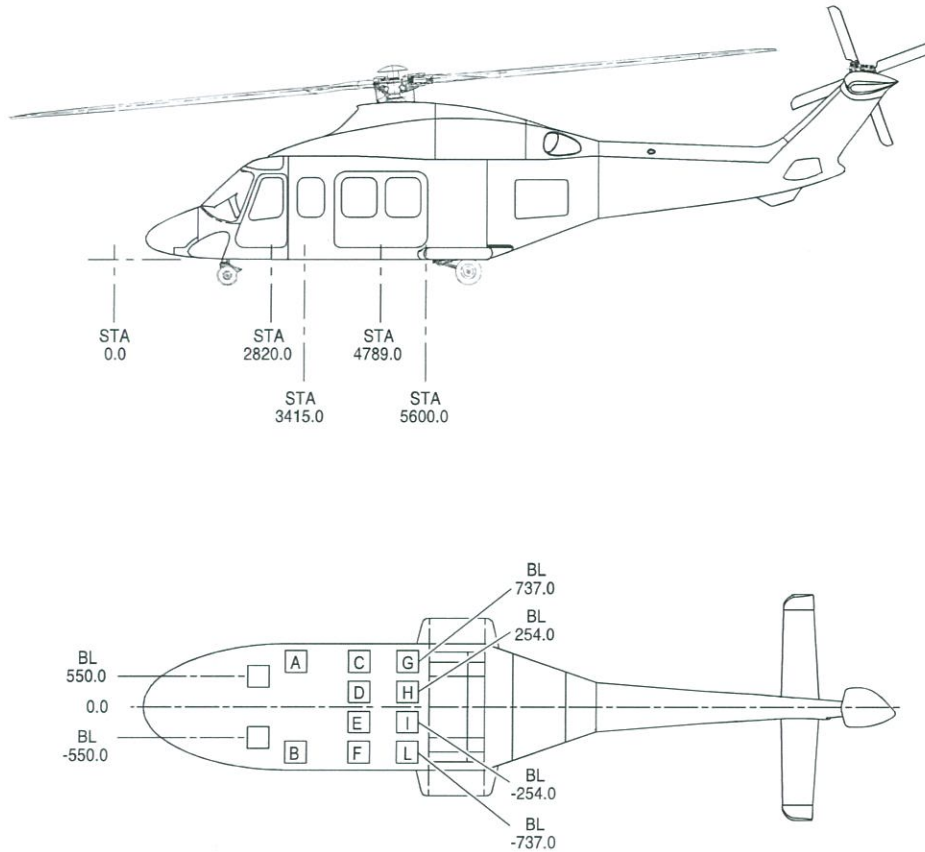

| NO. | ITEM | WEIGHT (KG) | ARM (MM) | |
|-----|-------------|-------------|----------|---------|
| | | | LONG. | LAT. |
| 1. | Passenger A | +Actual | 3415.00 | 737.00 |
| 2. | Passenger B | +Actual | 3415.00 | -737.00 |
| 3. | Passenger C | +Actual | 4789.00 | 737.00 |
| 4. | Passenger D | +Actual | 4789.00 | 254.00 |
| 5. | Passenger E | +Actual | 4789.00 | -254.00 |
| 6. | Passenger F | +Actual | 4789.00 | -737.00 |
| 7. | Passenger G | +Actual | 5600.00 | 737.00 |
| 8. | Passenger H | +Actual | 5600.00 | 254.00 |
| 9. | Passenger I | +Actual | 5600.00 | -254.00 |
| 10. | Passenger L | +Actual | 5600.00 | -737.00 |

| | |
|--------------|---------------------|
| Doc. ref. no | GAM/MBR/21/22/72-02 |
| Rev. Date | 24/12/2021 |
| Rev. No | 0 |

4.10. 8 SEATER

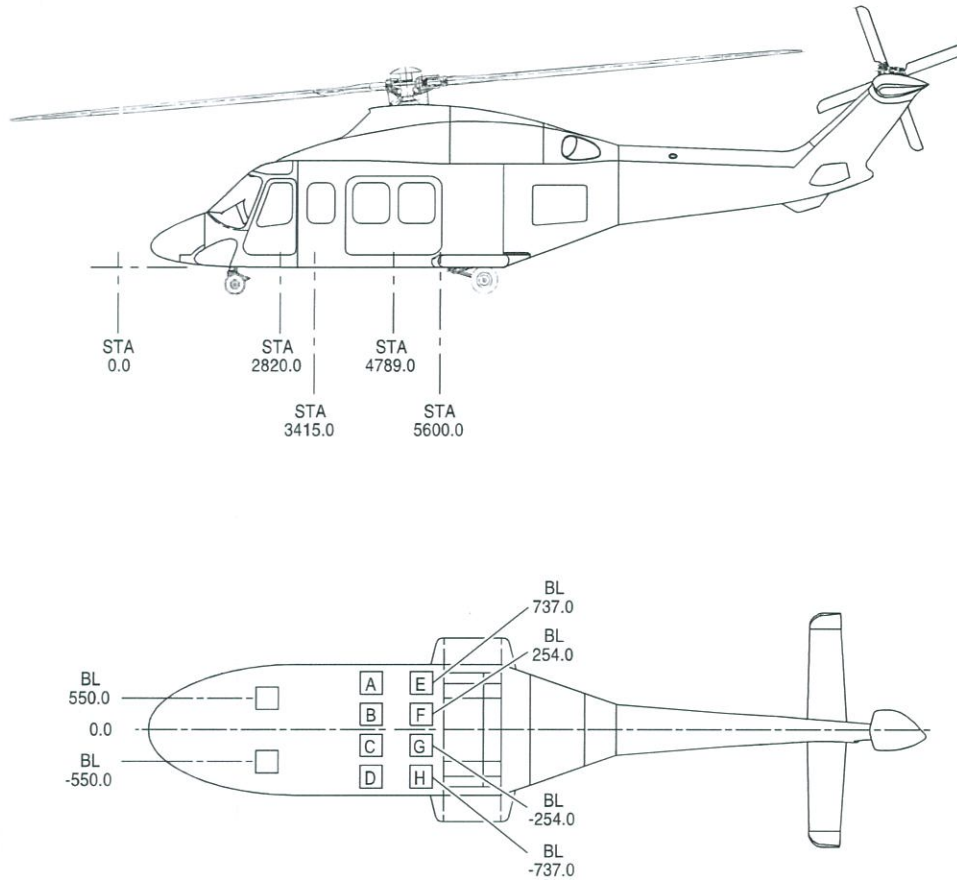

| NO. | ITEM | WEIGHT (KG) | ARM (MM) | |
|-----|-------------|-------------|----------|---------|
| | | | LONG. | LAT. |
| 1. | Passenger A | +Actual | 4789.00 | 737.00 |
| 2. | Passenger B | +Actual | 4789.00 | 254.00 |
| 3. | Passenger C | +Actual | 4789.00 | -254.00 |
| 4. | Passenger D | +Actual | 4789.00 | -737.00 |
| 5. | Passenger E | +Actual | 5600.00 | 737.00 |
| 6. | Passenger F | +Actual | 5600.00 | 254.00 |
| 7. | Passenger G | +Actual | 5600.00 | -254.00 |
| 8. | Passenger H | +Actual | 5600.00 | -737.00 |

| | |
|--------------|---------------------|
| Doc. ref. no | GAM/MBR/21/22/72-02 |
| Rev. Date | 24/12/2021 |
| Rev. No | 0 |

4.11. 4 SEATER

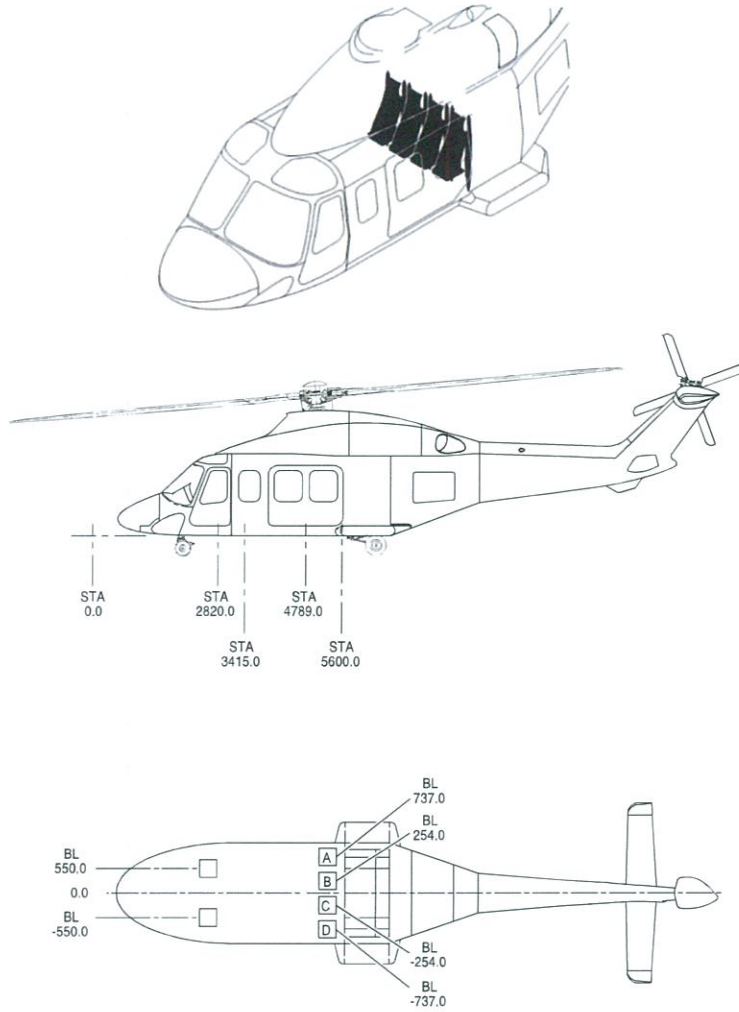

| NO. | ITEM | WEIGHT (KG) | ARM (MM) | |
|-----|-------------|-------------|----------|---------|
| | | | LONG. | LAT. |
| 1. | Passenger A | +Actual | 5600.00 | 737.00 |
| 2. | Passenger B | +Actual | 5600.00 | 254.00 |
| 3. | Passenger C | +Actual | 5600.00 | -254.00 |
| 4. | Passenger D | +Actual | 5600.00 | -737.00 |

| | |
|--------------|---------------------|
| Doc. ref. no | GAM/MBR/21/22/72-02 |
| Rev. Date | 24/12/2021 |
| Rev. No | 0 |

4.12. 4 SEATER

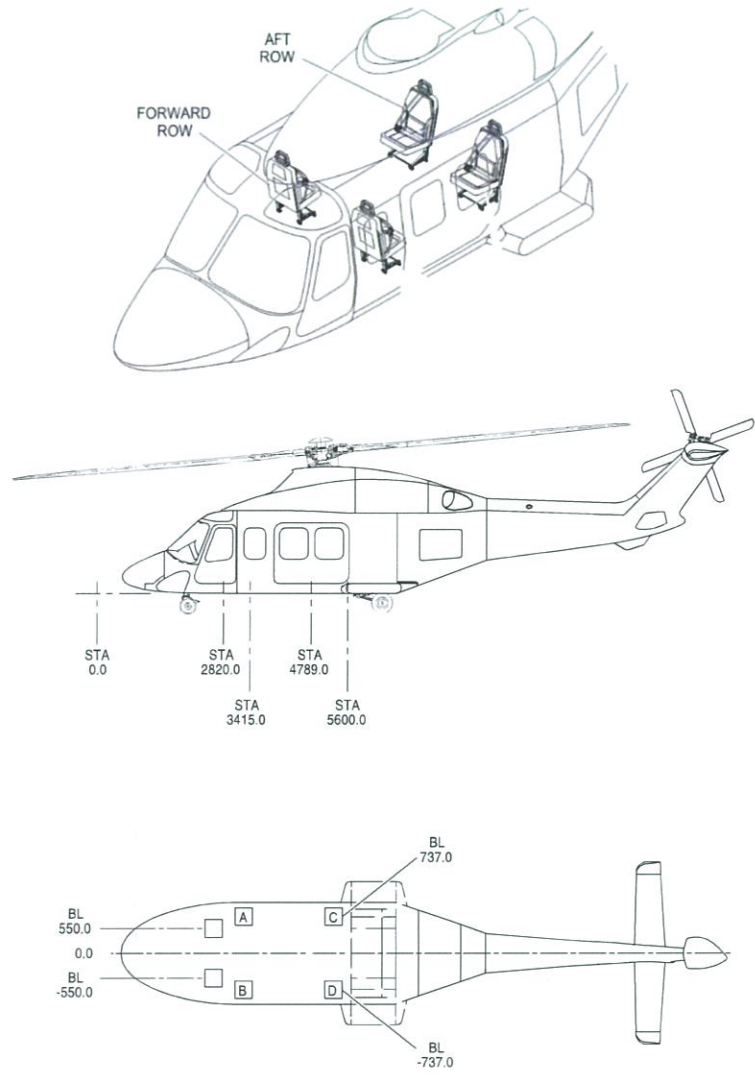

| NO. | ITEM | WEIGHT (KG) | ARM (MM) | |
|-----|-------------|-------------|----------|---------|
| | | | LONG. | LAT. |
| 1. | Passenger A | +Actual | 3415.00 | 737.00 |
| 2. | Passenger B | +Actual | 3415.00 | -737.00 |
| 3. | Passenger C | +Actual | 5600.00 | 737.00 |
| 4. | Passenger D | +Actual | 5600.00 | -737.00 |

| | |
|--------------|---------------------|
| Doc. ref. no | GAM/MBR/21/22/72-02 |
| Rev. Date | 24/12/2021 |
| Rev. No | 0 |

4.13. 3 SEATER

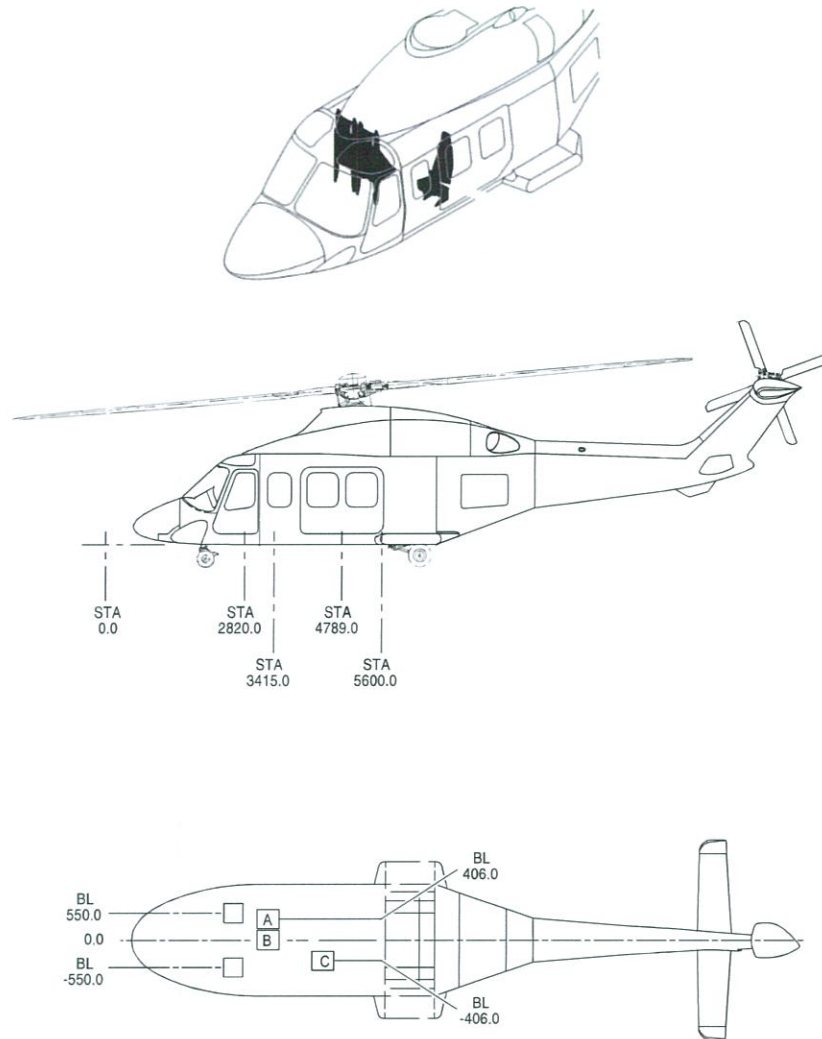

| NO. | ITEM | WEIGHT (KG) | ARM (MM) | |
|-----|-------------|-------------|----------|---------|
| | | | LONG. | LAT. |
| 1. | Passenger A | +Actual | 3415.00 | 406.00 |
| 2. | Passenger B | +Actual | 3415.00 | 0.00 |
| 3. | Passenger C | +Actual | 4789.00 | -406.00 |

| | |
|--------------|---------------------|
| Doc. ref. no | GAM/MBR/21/22/72-02 |
| Rev. Date | 24/12/2021 |
| Rev. No | 0 |

4.14. 4-STRETCHER / 5-SEAT (PN 4G2564F00411/412)

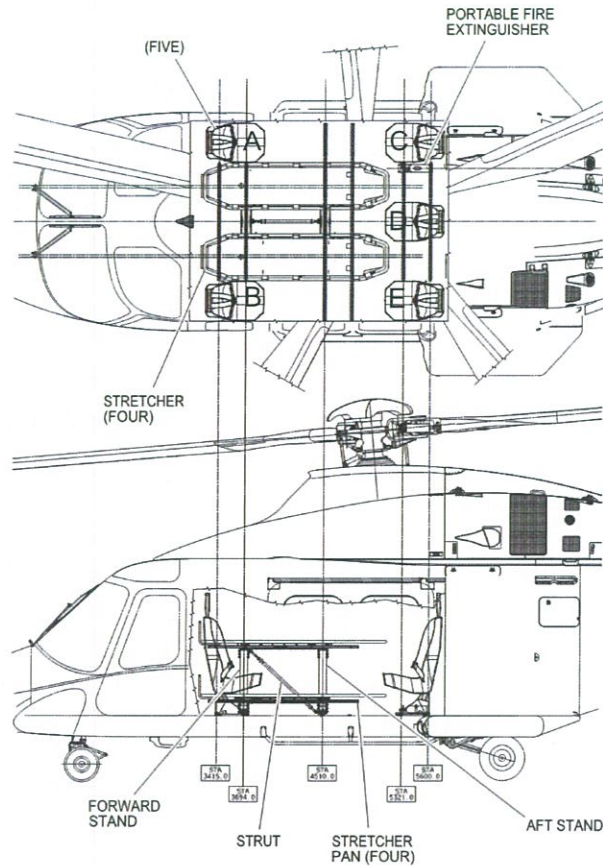

ICN-39-D-257300-G-00001-12181-A-001-01

| NO. | ITEM | WEIGHT (KG) | ARM (MM) | |
|-----|---------------------------------|-------------|----------|---------|
| | | | LONG. | LAT. |
| 1. | Passenger A | +Actual | 3449.00 | 813.00 |
| 2. | Passenger B | +Actual | 3449.00 | -813.00 |
| 3. | Passenger C | +Actual | 5600.00 | 813.00 |
| 4. | Passenger D | +Actual | 5600.00 | 0.00 |
| 5. | Passenger E | +Actual | 5600.00 | -813.00 |
| 6. | Patient on Stretcher (RH Upper) | +Actual | 4198.00 | 368.00 |
| 7. | Patient on Stretcher (LH Upper) | +Actual | 4198.00 | -368.00 |
| 8. | Patient on Stretcher (RH Lower) | +Actual | 4198.00 | 343.00 |
| 9. | Patient on Stretcher (LH Lower) | +Actual | 4198.00 | -343.00 |

| | |
|--------------|---------------------|
| Doc. ref. no | GAM/MBR/21/22/72-02 |
| Rev. Date | 24/12/2021 |
| Rev. No | 0 |

4.15. 4-STRETCHER / 4-SEAT (PN 4G2564F00419)

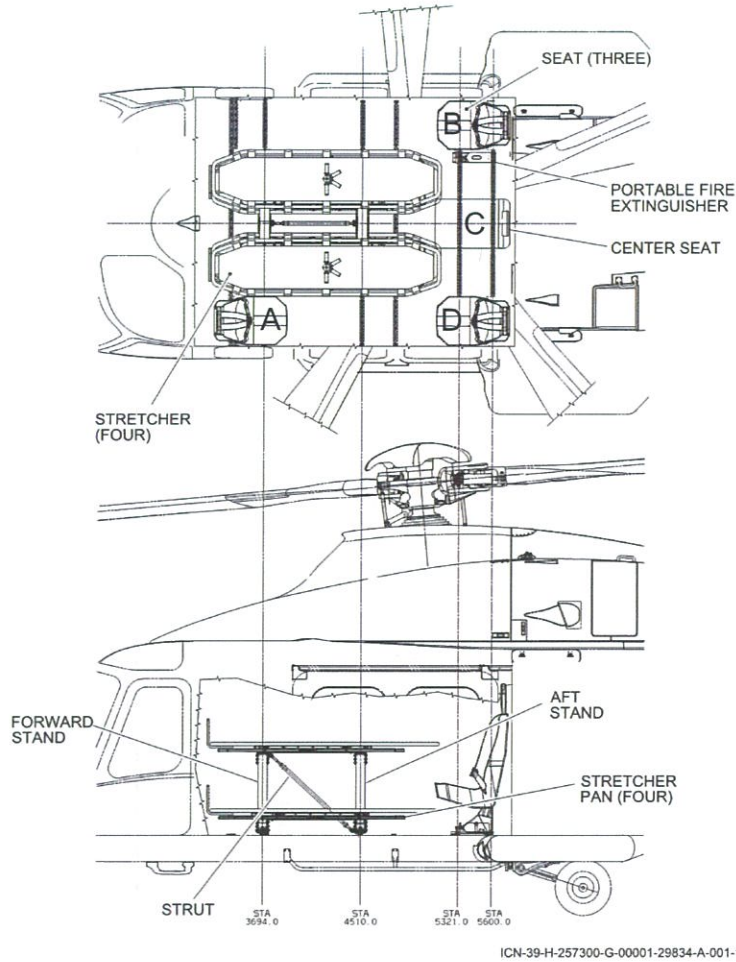

| NO. | ITEM | WEIGHT (KG) | ARM (MM) | |
|-----|---------------------------------|-------------|----------|---------|
| | | | LONG. | LAT. |
| 1. | Passenger A | +Actual | 3449.00 | -813.00 |
| 2. | Passenger B | +Actual | 5600.00 | 813.00 |
| 3. | Passenger C | +Actual | 5600.00 | 0.00 |
| 4. | Passenger D | +Actual | 5600.00 | -813.00 |
| 5. | Patient on Stretcher (RH Upper) | +Actual | 4198.00 | 368.00 |
| 6. | Patient on Stretcher (LH Upper) | +Actual | 4198.00 | -368.00 |
| 7. | Patient on Stretcher (RH Lower) | +Actual | 4198.00 | 343.00 |
| 8. | Patient on Stretcher (LH Lower) | +Actual | 4198.00 | -343.00 |

| | |
|--------------|---------------------|
| Doc. ref. no | GAM/MBR/21/22/72-02 |
| Rev. Date | 24/12/2021 |
| Rev. No | 0 |

4.16. 4-STRETCHER / 2-SEAT (PN 4G2564F00413/416)

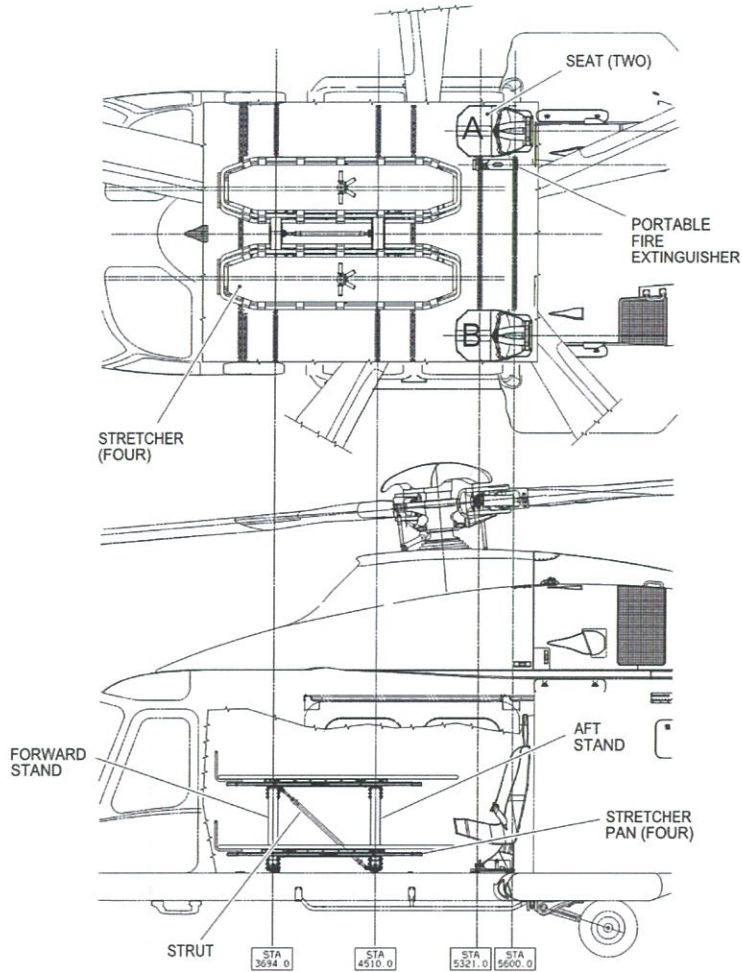

ICN-39-E-257300-G-00001-12182-A-001-01

| NO. | ITEM | WEIGHT (KG) | ARM (MM) | |
|-----|---------------------------------|-------------|--|---------|
| | | | LONG. | LAT. |
| 1. | Passenger A | +Actual | 5600.00 | 813.00 |
| 2. | Passenger B | +Actual | 5600.00 | -813.00 |
| 3. | Patient on Stretcher (RH Upper) | +Actual | (PN /413) 4198.00 (PN /416) 4298.00 | 368.00 |
| 4. | Patient on Stretcher (LH Upper) | +Actual | (PN /413) 4198.00 (PN /416) 4298.00 | -368.00 |
| 5. | Patient on Stretcher (RH Lower) | +Actual | (PN /413) 4198.00 (PN /416) 4298.00 | 343.00 |
| 6. | Patient on Stretcher (LH Lower) | +Actual | (PN /413) 4198.00 (PN /416) 4298.00 | -343.00 |

| | |
|--------------|---------------------|
| Doc. ref. no | GAM/MBR/21/22/72-02 |
| Rev. Date | 24/12/2021 |
| Rev. No | 0 |

4.17. 2-STRETCHER / 4-SEAT (PN 4G2564F00414/417)

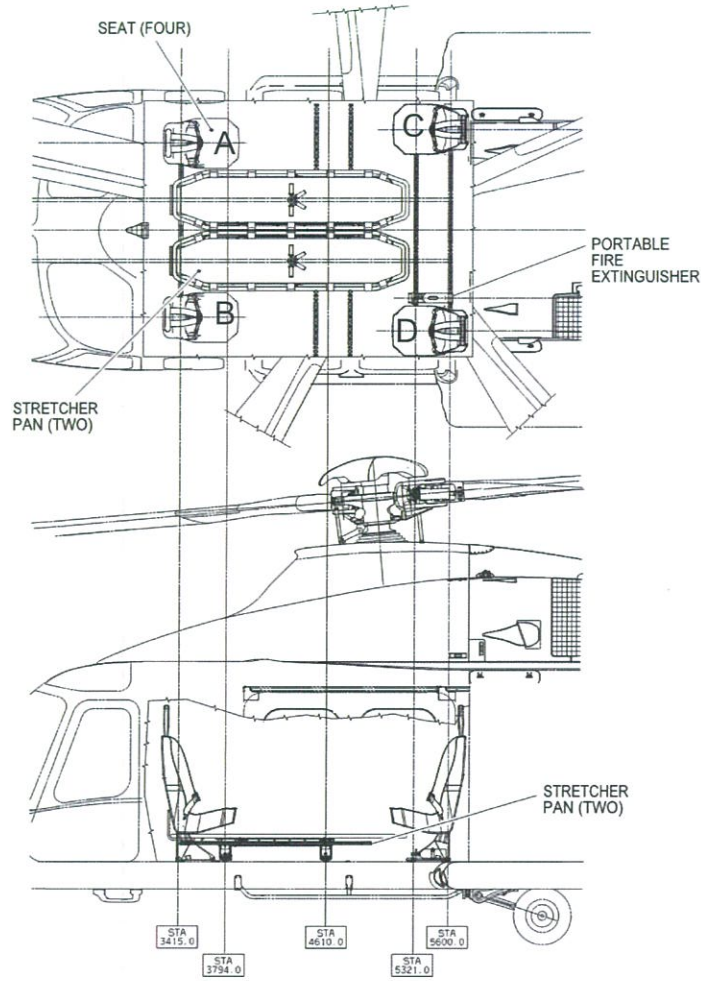

ICN-39-B-257400-G-00001-14221-A-001-01

| NO. | ITEM | WEIGHT (KG) | ARM (MM) | |
|-----|----------------------|-------------|-------------------|---------|
| | | | LONG. | LAT. |
| 1. | Passenger A | +Actual | 3449.00 | 703.00 |
| 2. | Passenger B | +Actual | 3449.00 | -703.00 |
| 3. | Passenger C | +Actual | 5600.00 | 813.00 |
| 4. | Passenger D | +Actual | 5600.00 | -813.00 |
| 5. | Patient on Stretcher | +Actual | (PN /414) 4198.00 | 246.00 |
| | | | (PN /417) 4298.00 | |
| 6. | Patient on Stretcher | +Actual | (PN /414) 4198.00 | -246.00 |
| | | | (PN /417) 4298.00 | |

| | |
|--------------|---------------------|
| Doc. ref. no | GAM/MBR/21/22/72-02 |
| Rev. Date | 24/12/2021 |
| Rev. No | 0 |

4.18. 1-STRETCHER RH / 5-SEAT (PN 4G2564F00415/418)

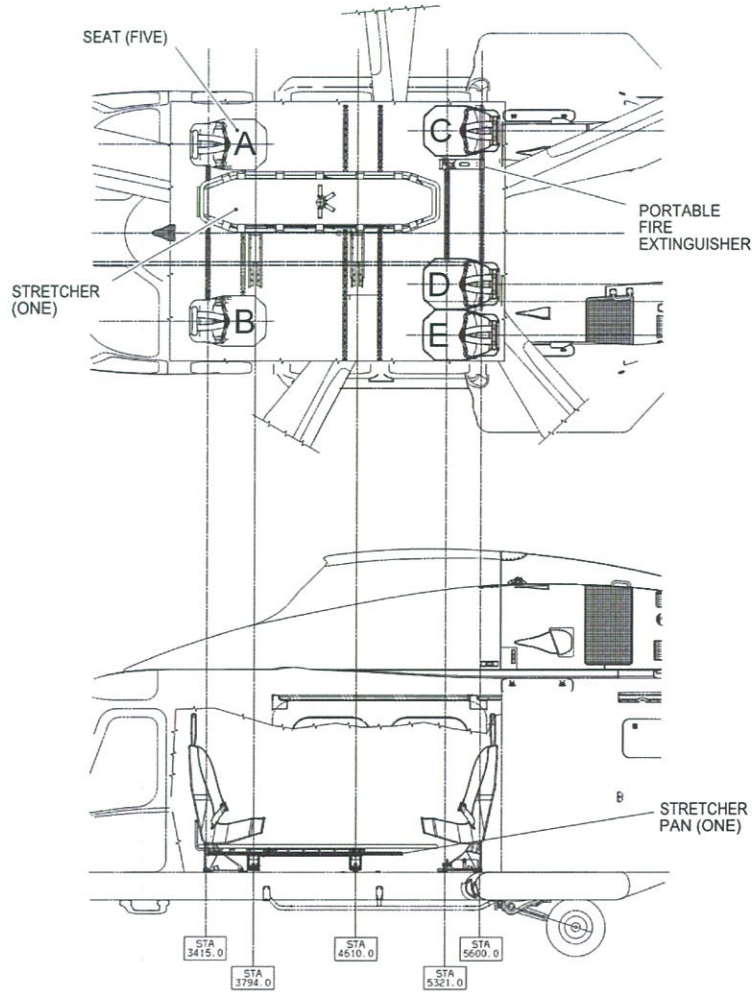

ICN-39-C-257400-G-00001-12186-A-001-01

| NO. | ITEM | WEIGHT (KG) | ARM (MM) | |
|-----|----------------------|-------------|-------------------|---------|
| | | | LONG. | LAT. |
| 1. | Passenger A | +Actual | 3449.00 | 703.00 |
| 2. | Passenger B | +Actual | 3449.00 | -703.00 |
| 3. | Passenger C | +Actual | 5600.00 | 813.00 |
| 4. | Passenger D | +Actual | 5600.00 | -406.00 |
| 5. | Passenger E | +Actual | 5600.00 | -813.00 |
| 6. | Patient on Stretcher | +Actual | (PN /415) 4198.00 | 246.00 |
| | | | (PN /418) 4298.00 | |

| | |
|--------------|---------------------|
| Doc. ref. no | GAM/MBR/21/22/72-02 |
| Rev. Date | 24/12/2021 |
| Rev. No | 0 |

4.19. 1-STRETCHER LH / 5-SEAT (P/N 4G2564F00415/418)

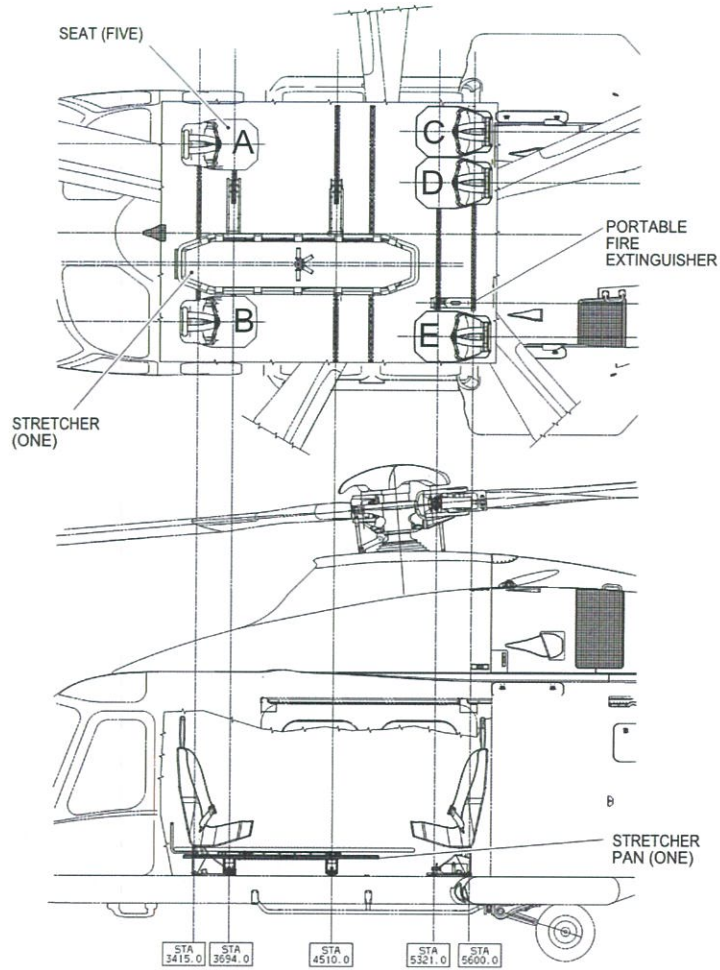

ICN-39-G-257300-G-00001-12184-A-001-01

| NO. | ITEM | WEIGHT (KG) | ARM (MM) | |
|-----|----------------------|-------------|--|---------|
| | | | LONG. | LAT. |
| 1. | Passenger A | +Actual | 3449.00 | 703.00 |
| 2. | Passenger B | +Actual | 3449.00 | -703.00 |
| 3. | Passenger C | +Actual | 5600.00 | 813.00 |
| 4. | Passenger D | +Actual | 5600.00 | 406.00 |
| 5. | Passenger E | +Actual | 5600.00 | -813.00 |
| 6. | Patient on Stretcher | +Actual | (PN /415) 4198.00 (PN /418) 4298.00 | -246.00 |

| | |
|--------------|---------------------|
| Doc. ref. no | GAM/MBR/21/22/72-02 |
| Rev. Date | 24/12/2021 |
| Rev. No | 0 |

4.20. 5-SEATER (FOLDABLE SEAT)

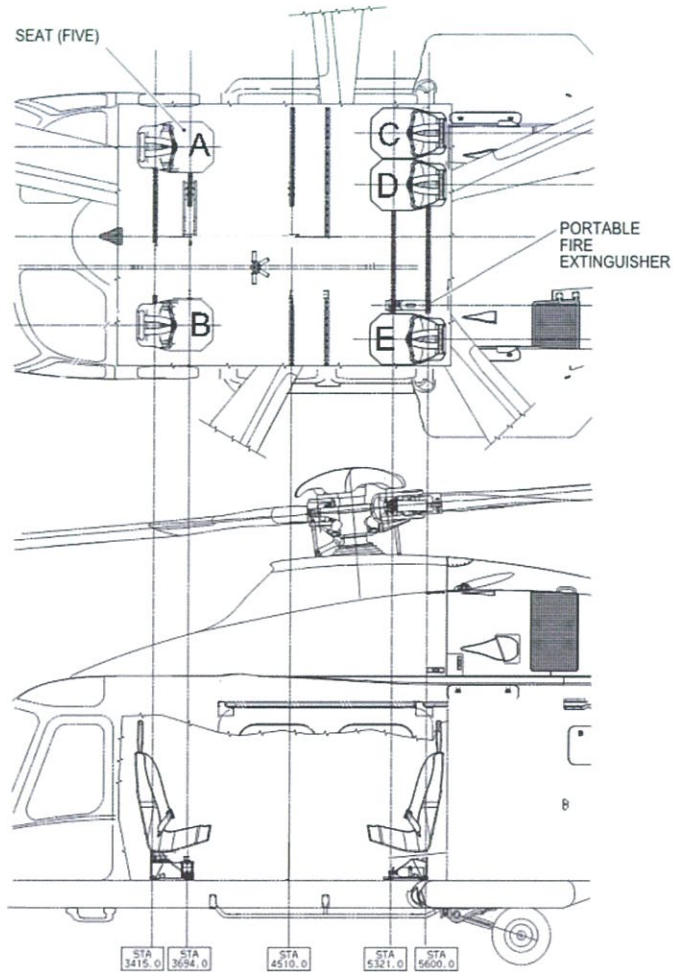

ICN-39-G-257300-G-00001-12184-A-001-01

| NO. | ITEM | WEIGHT (KG) | ARM (MM) | |
|-----|-------------|-------------|----------|---------|
| | | | LONG. | LAT. |
| 1. | Passenger A | +Actual | 3449.00 | 703.00 |
| 2. | Passenger B | +Actual | 3449.00 | -703.00 |
| 3. | Passenger C | +Actual | 5600.00 | 813.00 |
| 4. | Passenger D | +Actual | 5600.00 | 406.00 |
| 5. | Passenger E | +Actual | 5600.00 | -813.00 |

Mass And Balance Report

| | |
|--------------|---------------------|
| Doc. ref. no | GAM/MBR/21/22/72-02 |
| Rev. Date | 24/12/2021 |
| Rev. No | 0 |

4.21. SAR CONFIGURATION WITH RESCUE HOIST, LIFE RAFT, CARGO HOOK, SEARCH LIGHT & LOUDSPEAKER

| NO. | ITEM | WEIGHT (KG) | ARM (MM) | |
|-----|--------------------------------------|-------------|----------|--------|
| | | | LONG. | LAT. |
| 1. | Pilot | Actual | 2820 | 550 |
| 2. | Co-Pilot | Actual | 2820 | (-)550 |
| 3. | Kit Rescue Hoist | 112.02 | 4356 | - |
| | Complete Provision | 16.550 | 3643 | - |
| | Removable Parts | 84.310 | 4535 | - |
| 4. | Kit Cargo Hook | 25.500 | 4943 | - |
| | Complete Provision | 3.026 | 3299 | - |
| | Removable Parts | 21.370 | 5300 | - |
| 5. | Kit Life Raft | 91.935 | 6100 | - |
| | Complete Provision | 2.860 | 3142 | - |
| | Removable Parts | 89.075 | 6205 | - |
| 6. | Kit Search Light | 37.17 | 3694 | - |
| | Complete Provision | 3.290 | 3390 | - |
| | Removable Parts | 33.880 | 3724 | - |
| 7. | Kit Loud Speaker | 14.29 | 7254 | - |
| | Complete Provision | 2.140 | 5609 | - |
| 8. | Kit SAR 1 st Row Pax Seat | 30.73 | 3415 | - |
| 9. | Kit SAR 3 rd Row Pax Seat | 35.6 | 5287 | - |
| 10. | 1 st Row Pax Seat No.1 | Actual | 3335 | - |
| 11. | 1 st Row Pax Seat No.2 | Actual | 3335 | - |
| 12. | 3 rd Row Pax Seat No.1 | Actual | 5287 | - |
| 13. | 3 rd Row Pax Sear No.2 | Actual | 5287 | - |

4.22. SAR CONFIGURATION WITH RESCUE HOIST & LIFE RAFT

| NO. | ITEM | WEIGHT (KG) | ARM (MM) | |
|-----|--------------------------------------|-------------|----------|--------|
| | | | LONG. | LAT. |
| 1. | Pilot | Actual | 2820 | 550 |
| 2. | Co-Pilot | Actual | 2820 | (-)550 |
| 3. | Kit Rescue Hoist | 112.02 | 4356 | - |
| | Complete Provision | 16.550 | 3643 | - |
| | Removable Parts | 84.310 | 4535 | - |
| 4. | Kit Cargo Hook (removed) | (-)25.500 | 4943 | - |
| | Complete Provision | (-)3.026 | 3299 | - |
| | Removable Parts | (-)21.370 | 5300 | - |
| 5. | Kit Life Raft | 91.935 | 6100 | - |
| | Complete Provision | 2.860 | 3142 | - |
| | Removable Parts | 89.075 | 6205 | - |
| 6. | Kit Search Light (removed) | (-)37.17 | 3694 | - |
| | Complete Provision | (-)3.290 | 3390 | - |
| | Removable Parts | (-)33.880 | 3724 | - |
| 7. | Kit Loud Speaker (removed) | (-)14.29 | 7254 | - |
| | Complete Provision | (-)2.140 | 5609 | - |
| 8. | Kit SAR 1 st Row Pax Seat | 30.73 | 3415 | - |
| 9. | Kit SAR 3 rd Row Pax Seat | 35.6 | 5287 | - |
| 10. | 1 st Row Pax Seat No.1 | Actual | 3335 | - |

Mass And Balance Report

| | |
|--------------|---------------------|
| Doc. ref. no | GAM/MBR/21/22/72-02 |
| Rev. Date | 24/12/2021 |
| Rev. No | 0 |

| | | | | |
|--|-----------------------------------|--------|------|---|
| 11. | 1 st Row Pax Seat No.2 | Actual | 3335 | - |
| 12. | 3 rd Row Pax Seat No.1 | Actual | 5287 | - |
| 13. | 3 rd Row Pax Sear No.2 | Actual | 5287 | - |
| 4.23. SAR CONFIGURATION WITH RESCUE HOIST, LIFE RAFT & CARGO HOOK | | | | |

| NO. | ITEM | WEIGHT (KG) | ARM (MM) | |
|-----|--------------------------------------|-------------|----------|--------|
| | | | LONG. | LAT. |
| 1. | Pilot | Actual | 2820 | 550 |
| 2. | Co-Pilot | Actual | 2820 | (-)550 |
| 3. | Kit Rescue Hoist | 112.02 | 4356 | - |
| | Complete Provision | 16.550 | 3643 | - |
| | Removable Parts | 84.310 | 4535 | - |
| 4. | Kit Cargo Hook | 25.500 | 4943 | - |
| | Complete Provision | 3.026 | 3299 | - |
| | Removable Parts | 21.370 | 5300 | - |
| 5. | Kit Life Raft | 91.935 | 6100 | - |
| | Complete Provision | 2.860 | 3142 | - |
| | Removable Parts | 89.075 | 6205 | - |
| 6. | Kit Search Light (removed) | (-)37.17 | 3694 | - |
| | Complete Provision | (-)3.290 | 3390 | - |
| | Removable Parts | (-)33.880 | 3724 | - |
| 7. | Kit Loud Speaker (removed) | (-)14.29 | 7254 | - |
| | Complete Provision | (-)2.140 | 5609 | - |
| 8. | Kit SAR 1 st Row Pax Seat | 30.73 | 3415 | - |
| 9. | Kit SAR 3 rd Row Pax Seat | 35.6 | 5287 | - |
| 10. | 1 st Row Pax Seat No.1 | Actual | 3335 | - |
| 11. | 1 st Row Pax Seat No.2 | Actual | 3335 | - |
| 12. | 3 rd Row Pax Seat No.1 | Actual | 5287 | - |
| 13. | 3 rd Row Pax Sear No.2 | Actual | 5287 | - |

4.24. SAR CONFIGURATION WITH RESCUE HOIST, LIFE RAFT, CARGO HOOK & SEARCH LIGHT

| NO. | ITEM | WEIGHT (KG) | ARM (MM) | |
|-----|----------------------------|-------------|----------|--------|
| | | | LONG. | LAT. |
| 1. | Pilot | Actual | 2820 | 550 |
| 2. | Co-Pilot | Actual | 2820 | (-)550 |
| 3. | Kit Rescue Hoist | 112.02 | 4356 | - |
| | Complete Provision | 16.550 | 3643 | - |
| | Removable Parts | 84.310 | 4535 | - |
| 4. | Kit Cargo Hook | 25.500 | 4943 | - |
| | Complete Provision | 3.026 | 3299 | - |
| | Removable Parts | 21.370 | 5300 | - |
| 5. | Kit Life Raft | 91.935 | 6100 | - |
| | Complete Provision | 2.860 | 3142 | - |
| | Removable Parts | 89.075 | 6205 | - |
| 6. | Kit Search Light | 37.17 | 3694 | - |
| | Complete Provision | 3.290 | 3390 | - |
| | Removable Parts | 33.880 | 3724 | - |
| 7. | Kit Loud Speaker (removed) | (-)14.29 | 7254 | - |
| | Complete Provision | (-)2.140 | 5609 | - |

This document is the property of GALAXY AEROSPACE (M) SDN. BHD. (1040262-D), no part of it shall be reproduced or transmitted to third parties without the express prior written authorization of GALAXY AEROSPACE (M) SDN. BHD. nor shall its contents be disclosed.

Mass And Balance Report

| | |
|--------------|---------------------|
| Doc. ref. no | GAM/MBR/21/22/72-02 |
| Rev. Date | 24/12/2021 |
| Rev. No | 0 |

| | | | | |
|-----|--------------------------------------|--------|------|---|
| 8. | Kit SAR 1 st Row Pax Seat | 30.73 | 3415 | - |
| 9. | Kit SAR 3 rd Row Pax Seat | 35.6 | 5287 | - |
| 10. | 1 st Row Pax Seat No.1 | Actual | 3335 | - |
| 11. | 1 st Row Pax Seat No.2 | Actual | 3335 | - |
| 12. | 3 rd Row Pax Seat No.1 | Actual | 5287 | - |
| 13. | 3 rd Row Pax Sear No.2 | Actual | 5287 | - |

4.25. SAR SEATING CONFIGURATION

| NO. | ITEM | WEIGHT (KG) | ARM (MM) | |
|-----|--------------------------------------|-------------|----------|--------|
| | | | LONG. | LAT. |
| 1. | Pilot | Actual | 2820 | 550 |
| 2. | Co-Pilot | Actual | 2820 | (-)550 |
| 3. | Kit Rescue Hoist (removed) | (-)112.02 | 4356 | - |
| | Complete Provision | (-)16.550 | 3643 | - |
| | Removable Parts | (-)84.310 | 4535 | - |
| 4. | Kit Cargo Hook (removed) | (-)25.500 | 4943 | - |
| | Complete Provision | (-)3.026 | 3299 | - |
| | Removable Parts | (-)21.370 | 5300 | - |
| 5. | Kit Life Raft (removed) | (-)91.935 | 6100 | - |
| | Complete Provision | (-)2.860 | 3142 | - |
| | Removable Parts | (-)89.075 | 6205 | - |
| 6. | Kit Search Light (removed) | (-)37.17 | 3694 | - |
| | Complete Provision | (-)3.290 | 3390 | - |
| | Removable Parts | (-)33.880 | 3724 | - |
| 7. | Kit Loud Speaker (removed) | (-)14.29 | 7254 | - |
| | Complete Provision | (-)2.140 | 5609 | - |
| 8. | Kit SAR 1 st Row Pax Seat | 30.73 | 3415 | - |
| 9. | Kit SAR 3 rd Row Pax Seat | 35.6 | 5287 | - |
| 10. | 1 st Row Pax Seat No.1 | Actual | 3335 | - |
| 11. | 1 st Row Pax Seat No.2 | Actual | 3335 | - |
| 12. | 3 rd Row Pax Seat No.1 | Actual | 5287 | - |
| 13. | 3 rd Row Pax Sear No.2 | Actual | 5287 | - |

4.26. SAR CONFIGURATION WITH RESCUE HOIST

| NO. | ITEM | WEIGHT (KG) | ARM (MM) | |
|-----|----------------------------|-------------|----------|--------|
| | | | LONG. | LAT. |
| 1. | Pilot | Actual | 2820 | 550 |
| 2. | Co-Pilot | Actual | 2820 | (-)550 |
| 3. | Kit Rescue Hoist | 112.02 | 4356 | - |
| | Complete Provision | 16.550 | 3643 | - |
| | Removable Parts | 84.310 | 4535 | - |
| 4. | Kit Cargo Hook (removed) | (-)25.500 | 4943 | - |
| | Complete Provision | (-)3.026 | 3299 | - |
| | Removable Parts | (-)21.370 | 5300 | - |
| 5. | Kit Life Raft (removed) | (-)91.935 | 6100 | - |
| | Complete Provision | (-)2.860 | 3142 | - |
| | Removable Parts | (-)89.075 | 6205 | - |
| 6. | Kit Search Light (removed) | (-)37.17 | 3694 | - |
| | Complete Provision | (-)3.290 | 3390 | - |

This document is the property of GALAXY AEROSPACE (M) SDN. BHD. (1040262-D), no part of it shall be reproduced or transmitted to third parties without the express prior written authorization of GALAXY AEROSPACE (M) SDN. BHD. nor shall its contents be disclosed.

Mass And Balance Report

| | |
|--------------|---------------------|
| Doc. ref. no | GAM/MBR/21/22/72-02 |
| Rev. Date | 24/12/2021 |
| Rev. No | 0 |

| | | | | |
|-----|--|----------------------|--------------|--------|
| | Removable Parts | (-)33.880 | 3724 | - |
| 7. | Kit Loud Speaker (removed) Complete Provision | (-)14.29 (-)2.140 | 7254 5609 | - - |
| 8. | Kit SAR 1 st Row Pax Seat | 30.73 | 3415 | - |
| 9. | Kit SAR 3 rd Row Pax Seat | 35.6 | 5287 | - |
| 10. | 1 st Row Pax Seat No.1 | Actual | 3335 | - |
| 11. | 1 st Row Pax Seat No.2 | Actual | 3335 | - |
| 12. | 3 rd Row Pax Seat No.1 | Actual | 5287 | - |
| 13. | 3 rd Row Pax Sear No.2 | Actual | 5287 | - |

4.27. SAR CONFIGURATION WITH CARGO HOOK

| NO. | ITEM | WEIGHT (KG) | ARM (MM) | |
|-----|---|-------------------------------------|----------------------|-------------|
| | | | LONG. | LAT. |
| 1. | Pilot | Actual | 2820 | 550 |
| 2. | Co-Pilot | Actual | 2820 | (-)550 |
| 3. | Kit Rescue Hoist (removed) Complete Provision Removable Parts | (-)112.02 (-)16.550 (-)84.310 | 4356 3643 4535 | - - - |
| 4. | Kit Cargo Hook Complete Provision Removable Parts | 25.500 3.026 21.370 | 4943 3299 5300 | - - - |
| 5. | Kit Life Raft (removed) Complete Provision Removable Parts | (-)91.935 (-)2.860 (-)89.075 | 6100 3142 6205 | - - - |
| 6. | Kit Search Light (removed) Complete Provision Removable Parts | (-)37.17 (-)3.290 (-)33.880 | 3694 3390 3724 | - - - |
| 7. | Kit Loud Speaker (removed) Complete Provision | (-)14.29 (-)2140 | 7254 5609 | - - |
| 8. | Kit SAR 1 st Row Pax Seat | 30.73 | 3415 | - |
| 9. | Kit SAR 3 rd Row Pax Seat | 35.6 | 5287 | - |
| 10. | 1 st Row Pax Seat No.1 | Actual | 3335 | - |
| 11. | 1 st Row Pax Seat No.2 | Actual | 3335 | - |
| 12. | 3 rd Row Pax Seat No.1 | Actual | 5287 | - |
| 13. | 3 rd Row Pax Sear No.2 | Actual | 5287 | - |

4.28. SAR CONFIGURATION WITH LIFE RAFT

| NO. | ITEM | WEIGHT (KG) | ARM (MM) | |
|-----|---|-------------------------------------|----------------------|-------------|
| | | | LONG. | LAT. |
| 1. | Pilot | Actual | 2820 | 550 |
| 2. | Co-Pilot | Actual | 2820 | (-)550 |
| 3. | Kit Rescue Hoist (removed) Complete Provision Removable Parts | (-)112.02 (-)16.550 (-)84.310 | 4356 3643 4535 | - - - |
| 4. | Kit Cargo Hook (removed) Complete Provision Removable Parts | (-)25.500 (-)3.026 (-)21.370 | 4943 3299 5300 | - - - |

This document is the property of GALAXY AEROSPACE (M) SDN. BHD. (1040262-D), no part of it shall be reproduced or transmitted to third parties without the express prior written authorization of GALAXY AEROSPACE (M) SDN. BHD. nor shall its contents be disclosed.

Mass And Balance Report

| | |
|--------------|---------------------|
| Doc. ref. no | GAM/MBR/21/22/72-02 |
| Rev. Date | 24/12/2021 |
| Rev. No | 0 |

| | | | | |
|-----|---|-----------------------------------|----------------------|-------------|
| 5. | Kit Life Raft Complete Provision Removable Parts | 91.935 2.860 89.075 | 6100 3142 6205 | - - - |
| 6. | Kit Search Light (removed) Complete Provision Removable Parts | (-)37.17 (-)3.290 (-)33.880 | 3694 3390 3724 | - - - |
| 7. | Kit Loud Speaker (removed) Complete Provision | (-)14.29 (-)2.140 | 7254 5609 | - - |
| 8. | Kit SAR 1 st Row Pax Seat | 30.73 | 3415 | - |
| 9. | Kit SAR 3 rd Row Pax Seat | 35.6 | 5287 | - |
| 10. | 1 st Row Pax Seat No.1 | Actual | 3335 | - |
| 11. | 1 st Row Pax Seat No.2 | Actual | 3335 | - |
| 12. | 3 rd Row Pax Seat No.1 | Actual | 5287 | - |
| 13. | 3 rd Row Pax Sear No.2 | Actual | 5287 | - |

4.29. SAR CONFIGURATION WITH SEARCH LIGHT

| NO. | ITEM | WEIGHT (KG) | ARM (MM) | |
|-----|---|-------------------------------------|----------------------|-------------|
| | | | LONG. | LAT. |
| 1. | Pilot | Actual | 2820 | 550 |
| 2. | Co-Pilot | Actual | 2820 | (-)550 |
| 3. | Kit Rescue Hoist (removed) Complete Provision Removable Parts | (-)112.02 (-)16.550 (-)84.310 | 4356 3643 4535 | - - - |
| 4. | Kit Cargo Hook (removed) Complete Provision Removable Parts | (-)25.500 (-)3.026 (-)21.370 | 4943 3299 5300 | - - - |
| 5. | Kit Life Raft (removed) Complete Provision Removable Parts | (-)91.935 (-)2.860 (-)89.075 | 6100 3142 6205 | - - - |
| 6. | Kit Search Light Complete Provision Removable Parts | 37.17 3.290 33.880 | 3694 3390 3724 | - - - |
| 7. | Kit Loud Speaker (removed) Complete Provision | (-)14.29 (-)2.140 | 7254 5609 | - - |
| 8. | Kit SAR 1 st Row Pax Seat | 30.73 | 3415 | - |
| 9. | Kit SAR 3 rd Row Pax Seat | 35.6 | 5287 | - |
| 10. | 1 st Row Pax Seat No.1 | Actual | 3335 | - |
| 11. | 1 st Row Pax Seat No.2 | Actual | 3335 | - |
| 12. | 3 rd Row Pax Seat No.1 | Actual | 5287 | - |
| 13. | 3 rd Row Pax Sear No.2 | Actual | 5287 | - |

4.30. SAR CONFIGURATION WITH LOUD SPEAKER

| NO. | ITEM | WEIGHT (KG) | ARM (MM) | |
|-----|--|------------------------|--------------|--------|
| | | | LONG. | LAT. |
| 1. | Pilot | Actual | 2820 | 550 |
| 2. | Co-Pilot | Actual | 2820 | (-)550 |
| 3. | Kit Rescue Hoist (removed) Complete Provision | (-)112.02 (-)16.550 | 4356 3643 | - - |

Mass And Balance Report





| | |
|--------------|---------------------|
| Doc. ref. no | GAM/MBR/21/22/72-02 |
| Rev. Date | 24/12/2021 |
| Rev. No | 0 |

| | | | | |
|-----|--------------------------------------|-----------|------|---|
| | Removable Parts | (-)84.310 | 4535 | - |
| 4. | Kit Cargo Hook (removed) | (-)25.500 | 4943 | - |
| | Complete Provision | (-)3.026 | 3299 | - |
| | Removable Parts | (-)21.370 | 5300 | - |
| 5. | Kit Life Raft (removed) | (-)91.935 | 6100 | - |
| | Complete Provision | (-)2.860 | 3142 | - |
| | Removable Parts | (-)89.075 | 6205 | - |
| 6. | Kit Search Light (removed) | (-)37.17 | 3694 | - |
| | Complete Provision | (-)3.290 | 3390 | - |
| | Removable Parts | (-)33.880 | 3724 | - |
| 7. | Kit Loud Speaker | 14.29 | 7254 | - |
| | Complete Provision | 2.140 | 5609 | - |
| 8. | Kit SAR 1 st Row Pax Seat | 30.73 | 3415 | - |
| 9. | Kit SAR 3 rd Row Pax Seat | 35.6 | 5287 | - |
| 10. | 1 st Row Pax Seat No.1 | Actual | 3335 | - |
| 11. | 1 st Row Pax Seat No.2 | Actual | 3335 | - |
| 12. | 3 rd Row Pax Seat No.1 | Actual | 5287 | - |
| 13. | 3 rd Row Pax Seat No.2 | Actual | 5287 | - |

| | |
|--------------|---------------------|
| Doc. ref. no | GAM/MBR/21/22/72-02 |
| Rev. Date | 24/12/2021 |
| Rev. No | 0 |

NOTE

1. To obtain the total loaded weight of aircraft, add to the BASIC Weight the weights of the items of variable and disposable load (if not included during weighing - see equipment list) to be carried for the particular role.
2. Loading information (disposable load) and CG envelope chart is available in Approved Flight Manual.
3. it is a requirement of the MCAR 2016 that the pilot-in-command satisfies himself before take-off that the load is of such mass, and is so distributed and secured, that it may safely be carried on the intended flight.
4. CAAM APPROVAL REFERENCE NUMBER: CAMO/2016/03
5. This MCGS was prepared on 24/12/2021 and supersedes all previous issues.

| | | | |
|--------------|---|-------|------------|
| Prepared by: |  | Date: | 24/12/2021 |
| | EZHAN IZZAD B. MOHD NOR | | |
| Checked by: |  | Date: | 24/12/2021 |
| | MOHD SHARIL B. MOHAMAD | | |
| Approved by: |   | Date: | 24/12/2021 |
| | NUR FARHANA OTHMAN | | |

| | |
|---------------|---------------------|
| Doc. Ref. No. | GAM/MBR/21/22/72-02 |
| Rev. Date | 24/12/2021 |
| Rev. No. | 0 |

SECTION 2- MASS AND BALANCE RECORD

PART 2A – WEIGHING RECORD (WR)

| | |
|----------------------|---|
| Location | : MIAT, Subang Hangar |
| Equipment | : ELECTRONIC WEIGHING SCALE FORM |
| Model / Part number | : INTERCOMP AC125LP-4C |
| Serial number | : 25702886 (#1), 25702887 (#2), 25702888 (#3) |
| Calibration due date | : 22/04/2021 |

MEASUREMENT

All station arms measured from datum, located 0 mm.
 Distance from datum point to forward jack point is 3160.00 mm.
 Distance from datum point to LH & RH aft jack points station is 6700.00 mm
 Data recorded from the weighing equipment is in lbs, and converted to kg (1 lbs = 0.4535924).
 In lateral calculations: Left is negative (-), Right is positive (+).
 Weight of fuel: 1 litre @ 0.8 kg.

FIRST WEIGHING (All Units in kg)

| JACK POINT | | | CELL READING | ZERO RTN. | CALIBRATION | ACTUAL WEIGHT |
|--------------|-----|------|--------------|-----------|-------------|---------------|
| LHD | AFT | (#3) | 1380.00 | 0.00 | 0.00 | 1380.00 |
| RHD | AFT | (#2) | 1427.00 | 0.00 | 0.00 | 1427.00 |
| NOSE | FWD | (#1) | 1676.00 | 0.00 | 0.00 | 1676.00 |
| TOTAL | | | | | | 4483.00 |

SECOND WEIGHING (All Units in kg)

| JACK POINT | | | CELL READING | ZERO RTN. | CALIBRATION | ACTUAL WEIGHT |
|--------------|-----|--------|--------------|-----------|-------------|---------------|
| LHD | AFT | RED | (#2) | 1382.00 | 0.00 | 1382.00 |
| RHD | AFT | YELLOW | (#1) | 1420.00 | 0.00 | 1420.00 |
| NOSE | FWD | BLUE | (#3) | 1673.00 | 0.00 | 1673.00 |
| TOTAL | | | | | | 4475.00 |

AVERAGE AIRCRAFT WEIGHT

| JACK POINT | | AVERAGE CELL READING (KG) | ARM (MM) | | MOMENT (KG.MM) | |
|--------------|-----|---------------------------|----------|---------|----------------|-------------|
| | | | LONG. | LAT. | LONG. | LAT. |
| LHD | AFT | 1381.00 | 6700.00 | -905.00 | 9252700.00 | -1249805.00 |
| RHD | AFT | 1423.50 | 6700.00 | 905.00 | 9537450.00 | 1288267.50 |
| NOSE | FWD | 1674.50 | 3160.00 | 0.00 | 5291420.00 | 0.00 |
| TOTAL | | 4479.00 | 5376.55 | 8.59 | 24081570.00 | 38462.50 |

Mass And Balance Report

| | |
|--------------|---------------------|
| Doc. ref. no | GAM/MBR/21/22/72-02 |
| Rev. Date | 24/12/2021 |
| Rev. No | 0 |

APPENDIX A – ADD THE FOLLOWING ITEM

| ITEM | DESCRIPTION OF ITEM | WEIGHT (KG) | ARM (MM) | | MOMENT (KG.MM) | |
|--------------|--|-------------|----------|-------|----------------|------|
| | | | LONG. | LAT. | LONG. | LAT. |
| 1. | UNUSABLE FUEL (MAIN TANK + AUXILIARY TANK) | 16.00 | 6206.00 | 16.00 | 99296.00 | 0.00 |
| TOTAL | | 16.00 | 6206.00 | 16.00 | 99296.00 | 0.00 |

APPENDIX B – SUBSTRACT THE FOLLOWING ITEM

| ITEM | DESCRIPTION OF ITEM | WEIGHT (KG) | ARM (MM) | | MOMENT (KG.MM) | |
|--------------|---------------------|-------------|----------|------|----------------|------|
| | | | LONG. | LAT. | LONG. | LAT. |
| 1. | NIL | 0.00 | 0.00 | 0.00 | 0.00 | 0.00 |
| TOTAL | | 0.00 | 0.00 | 0.00 | 0.00 | 0.00 |

CORRECTED CG LOCATION WITH RESPECT TO DATUM LINE

| ITEM ADDED AND SUBTRACTED | WEIGHT (KG) | ARM (MM) | | MOMENT (KG.MM) | |
|-------------------------------|-------------|----------|------|----------------|----------|
| | | LONG. | LAT. | LONG. | LAT. |
| AIRCRAFT BASIC WEIGHT | 4479.00 | 5376.55 | 8.59 | 24081570.00 | 38462.50 |
| PLUS – APPENDIX A | 16.00 | 6206.00 | 0.00 | 99296.00 | 0.00 |
| MINUS – APPENDIX B | 0.00 | 0.00 | 0.00 | 0.00 | 0.00 |
| CORRECTED BASIC WEIGHT | 4495.00 | 5379.50 | 8.56 | 24180866.00 | 38462.50 |

REMARKS:

| | |
|---------------------|---|
| Reason for weighing | : This Mass and Balance report reproduce to change GAM MBR form and amendment on the calibration date of the weighing equipment. Aircraft reweigh on 27 April 2020 due to aircraft repair. Weighing data is based on GAM weighing report GAM/WR/20/11/31315 dated 17 June 2020 |
| Weighing condition | : Inside Hangar |
| Hangar doors | : N/A |
| Main rotor blades | : Position Number 1 rotor blade align with the tail cone. |
| Aircraft doors | : Closed |
| Aircraft attitude | : Level longitudinally and laterally |
| Fuel tanks | : Drained |
| Fluids | : Serviced to normal flight condition. |
| Rotor Brake | : Set rotor brake to ON. Make sure rotor brake is engaged. |
| Landing Gear | : Extended |
| Configuration | : 5-Seater foldable Configuration |

| | |
|--------------|---------------------|
| Doc. ref. no | GAM/MBR/21/22/72-02 |
| Rev. Date | 24/12/2021 |
| Rev. No | 0 |

BASIC AIRCRAFT WEIGHING DIMENSIONS

Note 1

The forward lower Central Cabin is provided by two FWD jack points, only one FWD jack point is assured by using a proper tool which collect both jacking points.

The Station Reference Datum (STA 0) is located 3160 mm forward the FWD jack points. Therefore, the STA are positive.

E = Distance from the reference datum (STA 0) to the FWD jackpoint Station of 3160 mm.

F = Distance from the reference datum (STA 0) to the LH and RH aft jackpoints Station of 6700 mm.

Note 2

The Buttock Line Reference Datum (BL 0) is located on the fuselage Centre Line. Therefore, the BL are negative on the Left-Hand side and positive on the Right-Hand side.

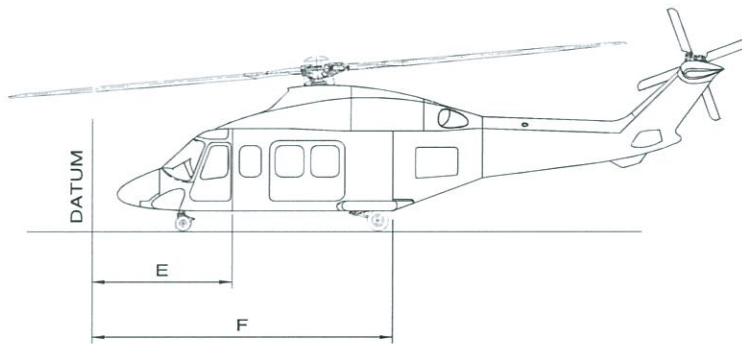

ICN-39-A-156000-A-00003-00029-A-01-1

JACKPOINTS LOCATION

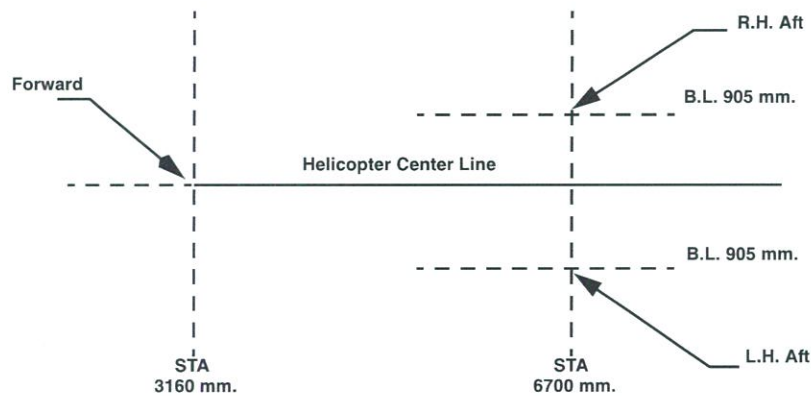

Longitudinal STA. 0 (Datum) is 3160 mm. Forward of the front jackpoint.

| Mass And Balance Report | |
|-------------------------|---------------------|
| Doc. ref. no | GAM/MBR/21/22/72-02 |
| Rev. Date | 24/12/2021 |
| Rev. No | 0 |

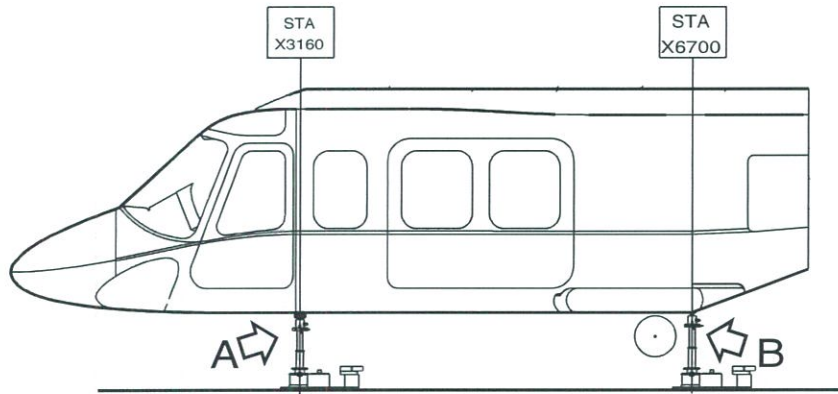
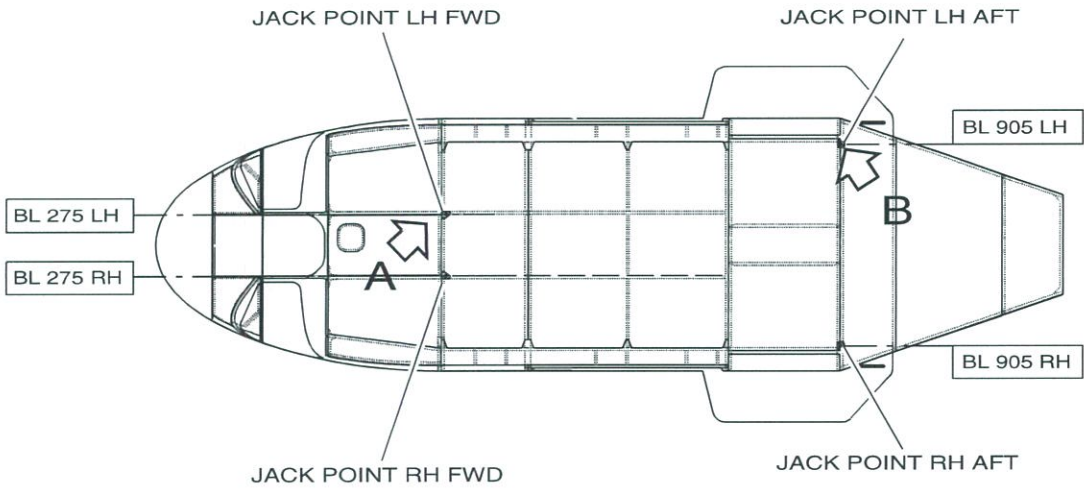

[AIRCRAFT & JACK STATION FIGURE]

| | |
|--------------|---------------------|
| Doc. ref. no | GAM/MBR/21/22/72-02 |
| Rev. Date | 24/12/2021 |
| Rev. No | 0 |

LONGITUDINAL AND LATERAL CG ENVELOPE CHART

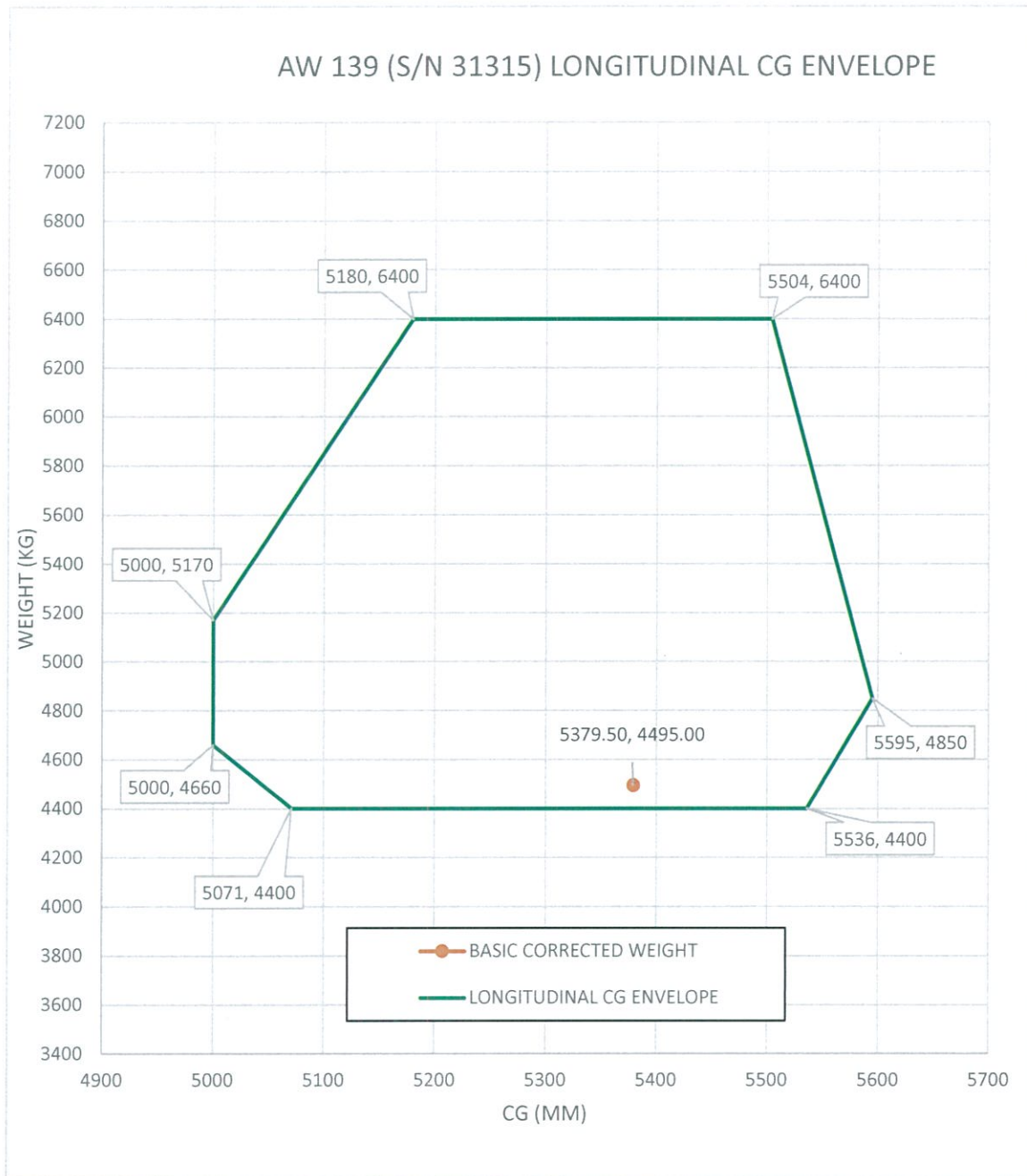

| | |
|--------------|---------------------|
| Doc. ref. no | GAM/MBR/21/22/72-02 |
| Rev. Date | 24/12/2021 |
| Rev. No | 0 |

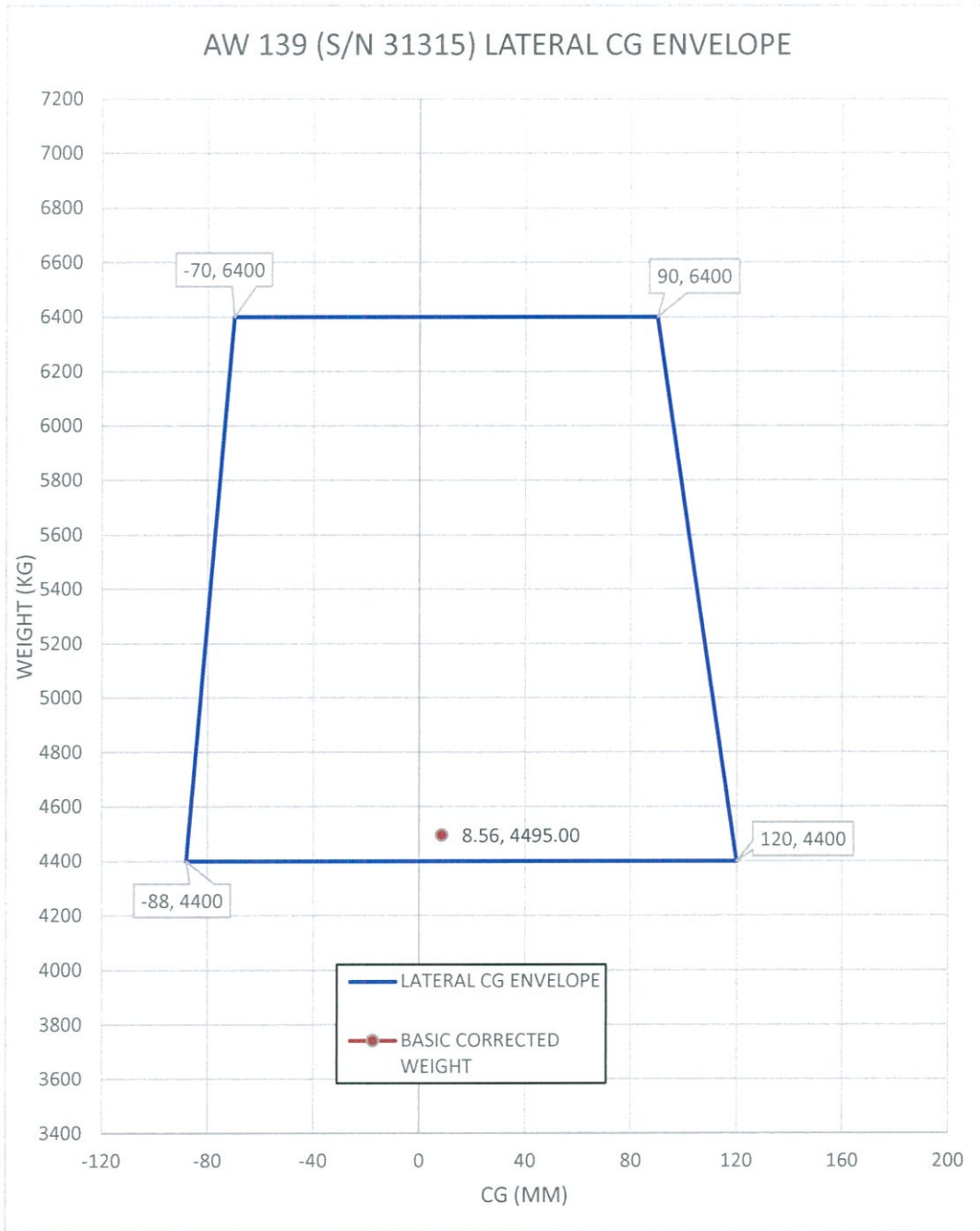

[LATERAL CG ENVELOPE CHART]

Mass And Balance Report

| | |
|--------------|---------------------|
| Doc. ref. no | GAM/MBR/21/22/72-02 |
| Rev. Date | 24/12/2021 |
| Rev. No | 0 |

PART 2B – EQUIPMENT LIST

| NO | EQUIPMENT | QTY | WEIGHT (kg) | LONG ARM (mm) |
|--------------------------------|-----------------------------------|-----|-------------|---------------|
| POWER PLANT SYSTEM | | | | |
| 1. | Free turbine turboshaft PT6C-67C | 2 | 200.310 | 6434.0 |
| 2. | DC generator | 2 | 13.800 | 7139.0 |
| 3. | Ejector duct installation | 1 | 33.848 | 7378.0 |
| TRANSMISSION AND ROTORS | | | | |
| 4. | Main rotor assy | 1 | 204.00 | 5007.0 |
| 5. | Main rotor damper | 5 | 5.070 | 5007.0 |
| 6. | Main rotor blade assy | 5 | 63.500 | 5007.0 |
| 7. | Tail rotor assy | 1 | 9.800 | 13410.0 |
| 8. | Tail rotor elastomeric damper | 4 | 0.522 | 13410.0 |
| 9. | Tail rotor blade assy | 4 | 4.255 | 13410.0 |
| 10. | Main gearbox assy | 1 | 397.000 | 5112.0 |
| 11. | Filter element | 1 | 0.240 | 5308.0 |
| 12. | Cooler MGB oil cooling | 1 | 5.000 | 5510.0 |
| 13. | Fan MGB oil cooling | 1 | 4.820 | 5542.0 |
| 14. | Input shaft | 2 | 1.700 | 5515.0 |
| 15. | Tail rotor shaft assy N.1 | 1 | 7.200 | 7034.0 |
| 16. | Tail rotor shaft assy N.2 | 1 | 6.170 | 10307.0 |
| 17. | Tail rotor shaft assy N.3 | 1 | 1.960 | 12796.0 |
| 18. | Intermediate gearbox assy | 1 | 16.650 | 12310.0 |
| 19. | Tail gearbox assy | 1 | 31.700 | 13372.0 |
| FUEL SYSTEM | | | | |
| 20. | Main left tank | 1 | 16.300 | 6236.0 |
| 21. | Main right tank | 1 | 16.400 | 6236.0 |
| 22. | Booster pump | 2 | 1.790 | 6279.0 |
| 23. | Fuel probe instl (ELDEC) | 1 | 5.350 | 6528.0 |
| 24. | Fuel control unit | 1 | 1.298 | 6958.0 |
| 25. | Secondary probe | 2 | 0.461 | 6210.0 |
| 26. | Main probe | 2 | 0.604 | 6180.0 |
| HYDRAULIC SYSTEM | | | | |
| 27. | Main rotor actuator N.1 (mark II) | 1 | 8.700 | 4740.0 |
| 28. | Main rotor actuator N.2 (mark II) | 1 | 8.700 | 5293.0 |
| 29. | Main rotor actuator N.3 (mark II) | 1 | 8.700 | 5293.0 |
| 30. | Tail rotor actuator (mark II) | 1 | 7.000 | 13410.0 |
| 31. | Power control module N.1 | 1 | 13.700 | 4567.0 |

Mass And Balance Report

| | |
|--------------|---------------------|
| Doc. ref. no | GAM/MBR/21/22/72-02 |
| Rev. Date | 24/12/2021 |
| Rev. No | 0 |

| NO | EQUIPMENT | QTY | WEIGHT (kg) | LONG ARM (mm) |
|--|---------------------------------------|-----|-------------|---------------|
| 32. | Power control module N.2 | 1 | 13.700 | 4510.0 |
| 33. | Hydraulic power supply N.1 (main) | 1 | 2.500 | 5094.0 |
| 34. | Hydraulic power supply N.2 (main) | 1 | 2.500 | 5094.0 |
| 35. | Hydraulic power supply N.3 (aux) | 1 | 2.500 | 4777.0 |
| 36. | Electric Motor Driver Hydraulic pump | 1 | 3.200 | 3639.0 |
| UTILITY HYDRAULIC SYSTEM AND LANDING GEAR | | | | |
| 37. | Landing gear control valve assy | 1 | 4.264 | 5020.0 |
| 38. | Wheel brake reservoir assy | 1 | 0.431 | 1015.0 |
| 39. | Wheel brake parking valve | 1 | 1.172 | 1676.0 |
| 40. | Nose landing gear assy | 1 | 24.550 | 1990.0 |
| 41. | Nose retracting actuator assy | 1 | 4.660 | 2568.0 |
| 42. | Nose wheel / tyre assy | 2 | 4.950 | 2028.0 |
| 43. | Nose wheel assy | 2 | 2.200 | 2028.0 |
| 44. | Nose tyre | 2 | 2.480 | 2028.0 |
| 45. | Left main landing gear assy | 1 | 44.139 | 6100.0 |
| 46. | Right main landing gear assy | 1 | 44.139 | 6100.0 |
| 47. | Main retracting actuator assy | 2 | 5.920 | 5758.0 |
| 48. | Main Wheel / Tyre assy | 2 | 10.375 | 6368.0 |
| 49. | Main wheel assy | 2 | 4.870 | 6368.0 |
| 50. | Main tyre | 2 | 5.260 | 6368.0 |
| 51. | Main brake assy | 2 | 7.550 | 6368.0 |
| ELECTRICAL SYSTEM | | | | |
| 52. | Pilot Master caution / warning assy | 1 | 0.300 | 2050.0 |
| 53. | Copilot Master caution / warning assy | 1 | 0.300 | 2050.0 |
| 54. | Main Battery | 1 | 36.900 | 1229.0 |
| 55. | STBY Battery | 1 | 12.500 | 1308.0 |
| 56. | DC generator control unit N.1 | 1 | 1.610 | 6751.0 |
| 57. | DC generator control unit N.2 | 1 | 1.610 | 6751.0 |
| 58. | Overhead switch panel assy | 1 | 1.305 | 2464.0 |
| 59. | Overhead circuit breaker panel assy | 1 | 9.524 | 2927.0 |
| 60. | Power Distribution Panel 1 | 1 | 4.250 | 3602.0 |
| 61. | Power Distribution Panel 2 | 1 | 4.650 | 3582.0 |
| 62. | Search light | 1 | 2.590 | 3360.0 |
| 63. | Landing/ Taxiing Light | 2 | 0.320 | 5640.0 |
| 64. | Emergency light | 2 | 0.190 | 5631.0 |
| 65. | Position light, winglet | 1 | 0.110 | 12380.0 |

Mass And Balance Report

| | |
|--------------|---------------------|
| Doc. ref. no | GAM/MBR/21/22/72-02 |
| Rev. Date | 24/12/2021 |
| Rev. No | 0 |

| NO | EQUIPMENT | QTY | WEIGHT (kg) | LONG ARM (mm) |
|--|-------------------------------------|-----|-------------|---------------|
| 66. | Position light, winglet | 1 | 0.110 | 12380.0 |
| 67. | Position light, tail | 1 | 0.150 | 14047.0 |
| 68. | Anti-collision light, tail | 1 | 0.635 | 13520.0 |
| INSTRUMENTS | | | | |
| 69. | Magnetic compass | 1 | 0.350 | 1940.0 |
| 70. | Clock | 2 | 0.113 | 2052.0 |
| 71. | Flat panel display unit | 4 | 6.786 | 2009.0 |
| 72. | Display controller | 2 | 1.000 | 2112.0 |
| 73. | Remote instrument control | 2 | 0.370 | 2154.0 |
| 74. | Left pitot static tube | 1 | 0.660 | 1750.0 |
| 75. | Right pitot static tube | 1 | 0.660 | 1750.0 |
| 76. | Standby indicator | 2 | 1.660 | 2000.0 |
| AVIONIC SYSTEM (RIGHT NOSE EQUIPMENT) | | | | |
| 77. | Modular radio cabinet N.2 | 1 | 13.947 | 1294.0 |
| 78. | Coupler marker beacon | 1 | 0.130 | 1484.0 |
| 79. | Air data module | 1 | 0.750 | 1475.0 |
| 80. | Modular avionic Unit N.2 | 1 | 10.367 | 902.0 |
| 81. | Attitude heading reference Unit N.2 | 1 | 2.200 | 1092.0 |
| AVIONIC SYSTEM (LEFT NOSE EQUIPMENT) | | | | |
| 82. | Modular radio cabinet N.1 | 1 | 9.366 | 1294.0 |
| 83. | Coupler glideslope | 1 | 0.130 | 1484.0 |
| 84. | Coupler VOR | 1 | 0.130 | 702.0 |
| 85. | Air data module | 1 | 0.750 | 1478.0 |
| 86. | Modular avionic Unit N.1 | 1 | 10.630 | 902.0 |
| 87. | Attitude heading reference unit N.1 | 1 | 2.200 | 1093.0 |
| AVIONIC SYSTEM (NOSE ANTENNAS INSTALLATION) | | | | |
| 88. | Antenna glide slope | 1 | 0.057 | 628.0 |
| AVIONIC SYSTEM (UPPER DECK ANTENNAS) | | | | |
| 89. | Antenna transponder | 1 | 0.170 | 8584.0 |
| AVIONIC SYSTEM (FUSELAGE ANTENNAS) | | | | |
| 90. | Antenna marker beacon | 1 | 0.450 | 2805.0 |
| 91. | Antenna transponder | 1 | 0.170 | 2950.0 |
| 92. | Antenna DME ant | 1 | 0.170 | 2971.0 |
| 93. | Antenna ADF | 1 | 1.587 | 3572.0 |
| 94. | Antenna VHF pilot com | 1 | 0.454 | 3536.0 |
| 95. | Antenna VHF/AM | 1 | 0.605 | 4943.0 |

Mass And Balance Report

| | |
|--------------|---------------------|
| Doc. ref. no | GAM/MBR/21/22/72-02 |
| Rev. Date | 24/12/2021 |
| Rev. No | 0 |

| NO | EQUIPMENT | QTY | WEIGHT (kg) | LONG ARM (mm) |
|--|--|-----|-------------|---------------|
| AVIONIC SYSTEM (REAR SECTION) | | | | |
| 96. | Radio altimeter | 1 | 2.086 | 6765.0 |
| 97. | Cockpit control unit | 1 | 0.280 | 7138.0 |
| AVIONIC SYSTEM (TAIL EQUIPMENT) | | | | |
| 98. | Flux valve N.2 | 1 | 0.680 | 9899.0 |
| 99. | Flux valve N.1 | 1 | 0.680 | 10155.0 |
| 100. | Multipurpose flight recorder | 1 | 3.100 | 9030.0 |
| AVIONIC SYSTEM (TAIL ANTENNAS) | | | | |
| 101. | Antenna radar altimeter (trasm) | 1 | 0.090 | 9937.0 |
| 102. | Antenna radar altimeter (rec) | 1 | 0.090 | 10758.0 |
| 103. | Antenna VOR (made of two parts) | 2 | 0.510 | 10186.0 |
| MISCELLANEOUS EQUIPMENT | | | | |
| 104. | Wiper motor converter RH | 1 | 3.100 | 1600.0 |
| 105. | Wiper motor converter LH | 1 | 3.100 | 1600.0 |
| 106. | Pilot seat assy, including safety belts | 1 | 14.500 | 2820.0 |
| 107. | Copilot seat assy, including safety belts | 1 | 14.500 | 2820.0 |
| 108. | Vibration absorber system | 1 | 21.200 | 3711.0 |
| 109. | Smoke detector | 1 | 0.600 | 8153.0 |
| AUXILIARY EQUIPMENTS - MISCELLANEOUS / VIBRATION ATTENUATION | | | | |
| 110. | Kit marin protection | 1 | 0.126 | 3527.0 |
| 111. | Kit mast vibration absorber | 1 | 34.030 | 4991.3 |
| AUXILIARY EQUIPMENTS – AIR VENTILATION, HEATING, CONDITIONING | | | | |
| 112. | Kit air conditioning | 1 | 97.130 | 3221.0 |
| AUXILIARY EQUIPMENTS – AUTOPILOT | | | | |
| 113. | Kit 4 axis enhanced f.d. with sar modes | 1 | -4.390 | 1089.0 |
| AUXILIARY EQUIPMENT – COMMUNICATIONS | | | | |
| 114. | Kit FLEXCOMM II (Complete provision & installation) | 1 | 14.790 | 6512.0 |
| 115. | Kit HF (Complete provision & installation) | 1 | 22.700 | 8482.0 |
| 116. | Kit external ICS hoist POLYCON (includes complete provision) | 1 | 2.070 | 3360.0 |
| 117. | External loudspeaker (Complete provision) | 1 | 2.140 | 5609.0 |
| 118. | Kit ICS AV900 cabin station 3 (soft liner) | 1 | 6.660 | 3514.0 |
| 119. | Kit ICS cabin utility (8 pax) | 1 | 16.600 | 4488.0 |
| AUXILIARY EQUIPMENT - ELECTRICAL POWER | | | | |
| 120. | Kit AC power single inverter | 1 | 3.000 | 4172.0 |
| 121. | Kit main battery 44ah (MARATHON) | 1 | 1.700 | 1721.0 |
| 122. | Kit utility CB panel RH | 1 | 0.700 | 3148.0 |

Mass And Balance Report

| | |
|--------------|---------------------|
| Doc. ref. no | GAM/MBR/21/22/72-02 |
| Rev. Date | 24/12/2021 |
| Rev. No | 0 |

| NO | EQUIPMENT | QTY | WEIGHT (kg) | LONG ARM (mm) |
|--|---|-----|-------------|---------------|
| 123. | Kit aux O/H panel installation | 1 | 2.145 | 2352.0 |
| AUXILIARY EQUIPMENTS - EQUIPMENTS/FURNISHING | | | | |
| 124. | Kit pedestal equipment rack | 1 | 4.450 | 3533.0 |
| 125. | Kit first row passenger seats (SAR) | 1 | 30.730 | 3415.0 |
| 126. | Passenger seat foldable including safety belts | 2 | 8.900 | 3335.0 |
| 127. | Kit third row passenger seats (SAR) | 1 | 35.600 | 5287.0 |
| 128. | Passenger seat foldable including safety belts | 3 | 8.900 | 5287.0 |
| 129. | Kit baggage compartment anchor system | 1 | 5.328 | 7676.0 |
| 130. | Kit cargo restrain net | 1 | 5.206 | 7849.0 |
| 131. | Kit first aid arabic | 1 | 0.336 | 3000.0 |
| 132. | Kit emergency locator transmitter | 1 | 6.560 | 8927.0 |
| 133. | Cargo hook complete provision | 1 | 3.026 | 3299.0 |
| 134. | Kit single rescue hoist GOODRICH (complete provision) | 1 | 112.020 | 4356.0 |
| AUXILIARY EQUIPMENTS – RAIN PROTECTION | | | | |
| 135. | Kit windshield washing | 1 | 1.910 | 1566.0 |
| AUXILIARY EQUIPMENTS - LIGHTS | | | | |
| 136. | Search light SX16 complete provision | 1 | 3.290 | 3390.0 |
| 137. | Kit 2nd anti-collision light | 1 | 1.335 | 6707.0 |
| 138. | Kit NVG | 1 | 7.646 | 6639.0 |
| 139. | Kit emergency floats (NVG) | 1 | 0.000 | 2810.0 |
| 140. | Kit external hoist (NVG) | 1 | -0.150 | 2850.0 |
| 141. | Kit digital map (NVG) | 1 | 0.000 | 2741.0 |
| 142. | Kit weather radar primus 701 (NVG) | 1 | 0.000 | 2647.0 |
| 143. | Kit V/UHF FLEXCOMM II (NVG) | 1 | 0.200 | 2699.0 |
| 144. | Kit windshield washing (NVG) | 1 | 0.000 | 2673.0 |
| 145. | Kit ICS hoist operator (NVG) | 1 | 0.000 | 3400.0 |
| 146. | Kit air conditioning (NVG) | 1 | 0.000 | 2579.0 |
| 147. | Kit heating (NVG) | 1 | 0.000 | 2588.0 |
| AUXILIARY EQUIPMENTS - NAVIGATION | | | | |
| 148. | Kit 2ND radar altimeter RT300 | 1 | 5.400 | 7510.0 |
| 149. | Kit weather radar PRIMUS 701 | 1 | 20.030 | 1548.0 |
| 150. | Kit GPS include complete provision | 1 | 3.790 | 4864.0 |
| 151. | Kit DF | 1 | 7.155 | 3730.0 |
| 152. | Kit AIS transponder include complete provision | 1 | 6.601 | 7351.0 |
| AUXILIARY EQUIPMENTS – SYSTEM INTEGRATION AND DISPLAY | | | | |
| 153. | Kit data management unit | 1 | 1.265 | 3035.0 |

Mass And Balance Report

| | |
|--------------|---------------------|
| Doc. ref. no | GAM/MBR/21/22/72-02 |
| Rev. Date | 24/12/2021 |
| Rev. No | 0 |





| NO | EQUIPMENT | QTY | WEIGHT (kg) | LONG ARM (mm) |
|--|---|-----|-------------|---------------|
| 154. | Kit central SKYQUEST display | 1 | 3.220 | 2094.0 |
| AUXILIARY EQUIPMENTS – FUSELAGE STRUCTURE | | | | |
| 155. | Kit MLG fairings step area extension | 1 | 1.282 | 6950.0 |
| 156. | Kit full cabin extension | 1 | 15.200 | 5630.0 |
| AUXILIARY EQUIPMENTS - DOORS, FOOTSTEPS | | | | |
| 157. | Kit rigid handle on pax door | 1 | 0.185 | 5055.0 |
| 158. | Kit footsteps pilot | 1 | 1.667 | 2987.0 |
| AUXILIARY EQUIPMENTS – WINDOWS | | | | |
| 159. | Kit crew sliding window LH | 1 | 6.373 | 3523.0 |
| 160. | Kit crew sliding window RH | 1 | 6.359 | 3521.0 |
| AUXILIARY EQUIPMENTS - MAIN ROTOR DRIVE | | | | |
| 161. | Kit rotor brake | 1 | 13.950 | 4808.0 |
| 162. | Kit Increased T/R pitch angle | 1 | 0.110 | 9860.0 |
| AUXILIARY EQUIPMENTS - SURVEILLANCE | | | | |
| 163. | Kit video downlink | 1 | 14.448 | 5894.0 |
| 164. | Kit digital map EURONAV V include complete provision | 1 | 10.100 | 5017.0 |
| AUXILIARY EQUIPMENTS - CREW ESCAPE AND SAFETY | | | | |
| 165. | Kit Liferaft (includes completes provision & removable parts) | 1 | 92.392 | 6100.0 |
| 166. | Life raft removable parts | 1 | 89.075 | 6205.0 |
| 167. | EFS complete provision | 1 | 8.282 | 4900.00 |
| AUXILIARY EQUIPMENTS - IMAGES RECORDING | | | | |
| 168. | Kit digital video audio recorder | 1 | 3.110 | 3467.0 |
| 169. | Kit cargo hook camera | 1 | 3.110 | 3467.0 |
| 170. | External video camera removable parts (from N/C 31075) | 1 | 1.130 | 3475.0 |
| AUXILIARY EQUIPMENTS – METEOROLOGICAL AND ATMOSPHERIC | | | | |
| 171. | Tailboom reinforcement structural retro modification | 1 | 18.000 | 10081.0 |
| 172. | FWD bulkhead inst | 1 | - | - |

Mass And Balance Report

| | |
|--------------|---------------------|
| Doc. ref. no | GAM/MBR/21/22/72-02 |
| Rev. Date | 24/12/2021 |
| Rev. No | 0 |







NOTE

1. CAAM APPROVAL REFERENCE NUMBER: CAMO/2016/03
2. This WR and Equipment List were prepared on 24/12/2021 and supersedes all previous issues.

| | | | |
|--------------|---|-------|------------|
| Prepared by: |  | Date: | 24/12/2021 |
| | EZHAN IZZAD B. MOHD NOR | | |
| Checked by: |  | Date: | 24/12/2021 |
| | MOHD SHARIL B. MOHAMAD | | |
| Approved by: |   | Date: | 24/12/2021 |
| | NUR FARHANA OTHMAN | | |

APPENDIX – AIRCRAFT BASIC MASS AND BALANCE RECORD

(CONTINUOUS HISTORY OF CHANGES IN STRUCTURE OR EQUIPMENT AFFECTING MASS AND BALANCE)

| AIRCRAFT TYPE | AW139 | SERIAL NUMBER | 31315 | | | | | | REGISTRATION | M72-02 | | |
|---------------|--|---------------|---------------|----------|----------------|-------------|----------|----------------|------------------------------|----------|----------------|--|
| DATE | DESCRIPTION OF ARTICLE OR MODIFICATION | | WEIGHT CHANGE | | | | | | RUNNING TOTAL BASIC AIRCRAFT | | | SIGN & STAMP |
| | | | ADDED (+) | | | REMOVED (-) | | | WEIGHT (KG) | ARM (MM) | MOMENT (KG.MM) | |
| | | | WEIGHT (KG) | ARM (MM) | MOMENT (KG.MM) | WEIGHT (KG) | ARM (MM) | MOMENT (KG.MM) | | | | |
| 28/04/2020 | BASIC WEIGHT (WEIGHTED ON 27/04/2020) | LONGITUDINAL | - | - | - | - | - | - | 4495.00 | 5379.50 | 24180866.00 | AJ  |
| | | LATERAL | - | - | - | - | - | - | 4495.00 | 8.56 | 38462.50 | |
| 16/06/2020 | BT 139-393 | LONGITUDINAL | 0.57 | 5187.37 | 2856.80 | - | - | - | 4495.57 | 5379.46 | 24183722.80 | AJ  |
| | | LATERAL | 0.57 | 0 | 0 | - | - | - | 4495.57 | 8.56 | 38462.50 | |
| 16/06/2020 | CARGO HOOK | LONGITUDINAL | 21.370 | 5300 | 113261 | - | - | - | 4516.94 | 5379.08 | 24296983.80 | AJ  |
| | | LATERAL | 21.370 | 0 | 0 | - | - | - | 4516.94 | 8.52 | 38462.50 | |
| 16/06/2020 | EMERGENCY FLOAT SYSTEM | LONGITUDINAL | 72.596 | 61885 | 448999 | - | - | - | 4589.54 | 5391.83 | 24745982.80 | AJ  |
| | | LATERAL | 72.596 | 0 | 0 | - | - | - | 4589.54 | 8.38 | 38462.50 | |
| 16/06/2020 | LOUDSPEAKER | LONGITUDINAL | 12.150 | 7254 | 103660 | - | - | - | 4601.69 | 5400.12 | 24849642.80 | AJ  |
| | | LATERAL | 12.150 | 0 | 0 | - | - | - | 4601.69 | 8.36 | 38462.50 | |
| 16/06/2020 | SEARCH LIGHT | LONGITUDINAL | 33.880 | 3724 | 126169 | - | - | - | 4635.57 | 5387.87 | 24975811.80 | AJ  |
| | | LATERAL | 33.880 | 0 | 0 | - | - | - | 4635.57 | 8.30 | 38462.50 | |
| 16/06/2020 | FLIR | LONGITUDINAL | 49.500 | 1834.53 | 90809 | - | - | - | 4685.07 | 5350.32 | 25066620.80 | AJ  |
| | | LATERAL | 49.500 | 0 | 0 | - | - | - | 4685.07 | 8.21 | 38462.50 | |









Mass And Balance Report

Doc. ref. no

GAM/MBR/21/22/72-02

Rev. No

0

| AIRCRAFT TYPE | AW139 | SERIAL NUMBER | 31315 | | | | | | REGISTRATION | M72-02 | | |
|---------------|--|---------------|---------------|----------|----------------|-------------|----------|----------------|------------------------------|---------|-------------|--|
| DATE | DESCRIPTION OF ARTICLE OR MODIFICATION | | WEIGHT CHANGE | | | | | | RUNNING TOTAL BASIC AIRCRAFT | | | SIGN & STAMP |
| | | | ADDED (+) | | | REMOVED (-) | | | WEIGHT | ARM | MOMENT | |
| | | | WEIGHT (KG) | ARM (MM) | MOMENT (KG.MM) | WEIGHT (KG) | ARM (MM) | MOMENT (KG.MM) | (KG) | (MM) | (KG.MM) | |
| 17/06/2020 | HOIST | LONGITUDINAL | - | - | - | 84.31 | 4535.00 | 382346.00 | 4600.76 | 5365.26 | 24684274.80 | FA  |
| | | LATERAL | - | - | - | 84.31 | 0 | 0 | 4600.76 | 8.36 | 38462.50 | |
| 17/06/2020 | LIFERAFT | LONGITUDINAL | - | - | - | 89.075 | 6205.00 | 552701.00 | 4511.68 | 5348.69 | 24131573.80 | FA  |
| | | LATERAL | - | - | - | 89.075 | 0 | 0 | 4511.68 | 8.53 | 38462.50 | |
| 17/06/2020 | 1ST ROW SEAT (2X) | LONGITUDINAL | - | - | - | 17.80 | 3449.00 | 61374.40 | 4493.88 | 5356.22 | 24070199.40 | FA  |
| | | LATERAL | - | - | - | 17.80 | 0 | 0 | 4493.88 | 8.56 | 38462.50 | |
| 17/06/2020 | 3RD ROW SEAT (3X) | LONGITUDINAL | - | - | - | 26.70 | 5600.00 | 149520.00 | 4467.18 | 5354.76 | 23920679.40 | FA  |
| | | LATERAL | - | - | - | 26.70 | 0 | 0 | 4467.18 | 8.61 | 38462.50 | |
| 17/06/2020 | CARGO HOOK | LONGITUDINAL | - | - | - | 21.370 | 5300 | 113261 | 4445.81 | 5355.02 | 23807418.40 | FA  |
| | | LATERAL | - | - | - | 21.370 | 0 | 0 | 4445.81 | 8.65 | 38462.50 | |
| 17/06/2020 | EMERGENCY FLOAT SYSTEM | LONGITUDINAL | - | - | - | 72.596 | 61885 | 448999 | 4373.22 | 5341.25 | 23358419.40 | FA  |
| | | LATERAL | - | - | - | 72.596 | 0 | 0 | 4373.22 | 8.80 | 38462.50 | |
| 17/06/2020 | LOUDSPEAKER | LONGITUDINAL | - | - | - | 12.150 | 7254 | 103660 | 4361.07 | 5332.36 | 23254759.40 | FA  |
| | | LATERAL | - | - | - | 12.150 | 0 | 0 | 4361.07 | 8.82 | 38462.50 | |
| 17/06/2020 | SEARCH LIGHT | LONGITUDINAL | - | - | - | 33.880 | 3724 | 126169 | 4327.19 | 5344.95 | 23128590.40 | FA  |
| | | LATERAL | - | - | - | 33.880 | 0 | 0 | 4327.19 | 8.89 | 38462.50 | |
| 17/06/2020 | FLIR | LONGITUDINAL | - | - | - | 49.500 | 1834.53 | 90809 | 4277.69 | 5385.57 | 23037781.40 | FA  |
| | | LATERAL | - | - | - | 49.500 | 0 | 0 | 4277.69 | 8.99 | 38462.50 | |











Mass And Balance Report

Doc. ref. no

GAM/MBR/21/22/72-02

Rev. No

0

| AIRCRAFT TYPE | AW139 | SERIAL NUMBER | 31315 | | | | | | REGISTRATION | M72-02 | | |
|---------------|--|---------------|---------------|----------|----------------|-------------|----------|----------------|------------------------------|----------|----------------|---|
| DATE | DESCRIPTION OF ARTICLE OR MODIFICATION | | WEIGHT CHANGE | | | | | | RUNNING TOTAL BASIC AIRCRAFT | | | SIGN & STAMP |
| | | | ADDED (+) | | | REMOVED (-) | | | WEIGHT (KG) | ARM (MM) | MOMENT (KG.MM) | |
| | | | WEIGHT (KG) | ARM (MM) | MOMENT (KG.MM) | WEIGHT (KG) | ARM (MM) | MOMENT (KG.MM) | | | | |
| 11/09/2020 | REMOVAL OF MAIN BATTERY (PN: 33204-002) | LONGITUDINAL | - | - | - | 36.90 | 1229.00 | 45350.10 | 4240.79 | 5421.73 | 22992431.30 |   |
| | | LATERAL | - | - | - | 36.90 | 0 | 0 | 4240.79 | 9.07 | 38462.50 | |
| 11/09/2020 | INSTALLATION OF MAIN BATTERY (PN: 33204-001) | LONGITUDINAL | 36.00 | 1229.00 | 44244.00 | - | - | - | 4276.79 | 5386.44 | 23036675.30 |   |
| | | LATERAL | 36.00 | 0 | 0 | - | - | - | 4276.79 | 8.99 | 38462.50 | |
| 24/09/2020 | BT 139-417, REV I, PART I | LONGITUDINAL | 1.584 | 13410.00 | 21241.40 | - | - | - | 4278.37 | 5389.42 | 23057916.70 |   |
| | | LATERAL | 1.584 | 0 | 0 | - | - | - | 4278.37 | 8.99 | 38462.50 | |
| 13/01/2021 | REMOVAL OF MAIN BATTERY (PN: 33204-001) | LONGITUDINAL | - | - | - | 36.00 | 1229.00 | 44244.00 | 4242.37 | 5424.72 | 23013672.70 |   |
| | | LATERAL | - | - | - | 36.00 | 0 | 0 | 4242.37 | 9.07 | 38462.50 | |
| 13/01/2021 | INSTALLATION OF MAIN BATTERY (PN: 33204-002) | LONGITUDINAL | 36.90 | 1229.00 | 45350.10 | - | - | - | 4279.27 | 5388.54 | 23059022.80 |   |
| | | LATERAL | 36.90 | 0 | 0 | - | - | - | 4279.27 | 8.99 | 38462.50 | |
| | | LONGITUDINAL | | | | | | | | | | |
| | | LATERAL | | | | | | | | | | |
| | | LONGITUDINAL | | | | | | | | | | |
| | | LATERAL | | | | | | | | | | |
| | | LONGITUDINAL | | | | | | | | | | |
| | | LATERAL | | | | | | | | | | |