

From: Le Van Minh, Ivan PWC <ivan.le@pwc.ca>
Sent: Thursday, 29 February, 2024 4:11 PM
To: Wan Nur Addinie Wan Mohd Rahimi
Cc: ZATY NADHIRA MOHAMED ZUHARI; Amir Abdullah; syafiqismail@galaxyaerospace.my; TECHNICAL SERVICES; Zarifah Irdina Sulong; amani@galaxyaerospace.my; husna@galaxyaerospace.my; harlina@galaxyaerospace.my; rusydi.galaxy@gmail.com
Subject: RE: [External] URGENT INQUIRY ON ENGINE PT6A-60A // ENGINE SERIAL NUMBER PCE-PK0985 CRM:08864000786

Hi Addinie,

There are 2 different type of hubs.

Early engines used an assembly of disks and blades like shown in the figure below as items 270 & 340. Neither are installed on PDRM fleet as they are all post SB13093.

SB 13093 introduced an integral bladed rotor (IBR), item 341 in the figure . PDRM are all post SB13093.

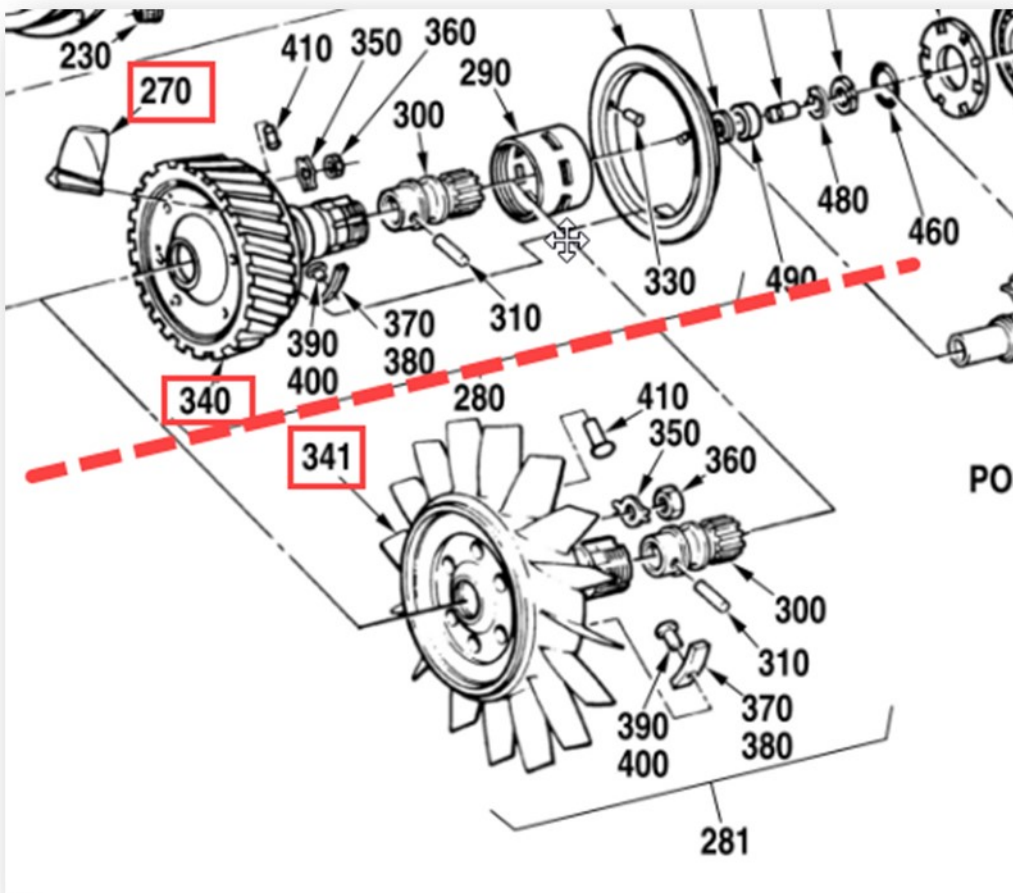

PK0985 LLP log shows PN 3041271 installed which is listed as item 341G in the IPC and has a an LCF limit of 15000 cycles.



Engine Component & Life Limited Parts Log

CUSTOMER HP MALAYSIA		DATE 16-03-2018	ENGINE MODEL PT6A-60A	ENGINE SERIAL No. PCE-PK0985
MODULE Gas Generator	SERIAL No. PCE-PK0985	TOTAL HOURS SINCE NEW 3561.05	TOTAL CYCLES SINCE NEW 2369	HC
MODULE Power Section	SERIAL No. PS-PK0985	TOTAL HOURS SINCE NEW 3561.05	TOTAL CYCLES SINCE NEW 2369	HC

Engine Internal LCF Life Limited Parts

Ref. Service Bulletin 13

Description	Part No	Serial No	TTSN	FCF
Hub, Comp - 1st Stage	3041271	EAAB000F427	3561.05	1
Disk, Comp - 2nd Stage	3034312	9M667	N/A	1
Disk, Comp - 3rd Stage	3034313	A0045L86	0.00	1
Impeller, Compressor	3036793	EAAB000K636	3561.05	1
Disk, Comp turbine	3040311	A002CTDP	3561.05	1
Disk, Power Turbine - 1st Stage	3029312	A002CLN0	3561.05	1.5
Disk, Power Turbine - 2nd Stage	3029313	A002CT7A	3561.05	1.5

Comments:

This should clarify what is installed and leaves only one of your question applicable;

1) During engine overhaul, does it include the replacement of a hub compressor?

The hub shall only be replaced during overhaul if it is found to be damaged beyond limits and not repairable or, if the cycles remaining is deemed to be insufficient to last until the next overhaul or, customer's option.

Let me know if you need me to explain further.

Regards,

Ivan LE

Manager - Field Support

Pratt & Whitney Canada

MALAYSIA (Thailand, Cambodia & Vietnam)

Mobile : +6 012 648 4264

email : ivan.le@pwc.ca

For 24-hour Global Service

Customer First Centre(CFirst)

Tel : +1 450 647 8000

email : cfirst@pwc.ca



Connect with P&WC through [live video](#). Talk to your [local FSM](#) for details about using Onsite.

This e-mail, including attachments, contains no technical data controlled by the United States Munitions List (USML), or more restrictively controlled than ECCN 9E991 on the United States Commerce Control List (CCL) (i.e. this email may contain EAR99, ECCN 9E991 or other data that is controlled only for Group E:1 countries).

This email, along with any attachments, is intended only for the addresses. Any unauthorized disclosure, use, copying, or distribution of the contents of this message, including attachments, is strictly prohibited. If received in error, please promptly notify the sender, and delete the original and all copies from your system.

From: Wan Nur Addinie Wan Mohd Rahimi <addinie.galaxy@gmail.com>
Sent: Thursday, February 29, 2024 9:49 AM
To: Le Van Minh, Ivan PWC <ivan.le@prattwhitney.com>
Cc: ZATY NADHIRA MOHAMED ZUHARI <zaty@galaxyaerospace.my>; Amir Abdullah <amirabdullah@galaxyaerospace.my>; syafiqismail@galaxyaerospace.my; TECHNICAL SERVICES <tech.services@galaxyaerospace.my>; Zarifah Irdina Sulong <zarifah.galaxyaerospace@gmail.com>; amani@galaxyaerospace.my; husna@galaxyaerospace.my; harlina@galaxyaerospace.my; rusydi.galaxy@gmail.com
Subject: Re: [External] URGENT INQUIRY ON ENGINE PT6A-60A // ENGINE SERIAL NUMBER PCE-PK0985

Hi Ivan,
Appreciate your prompt response.
Alright, I will be waiting for your advice.

Regards,

Addinie Rahimi

TECHNICAL SERVICE CAMO

for and on behalf of

GALAXY AEROSPACE (M) SDN BHD



No. A-01-02, Blok A, Bangunan Perdagangan Siera [Ara Damansara, Jalan PJU 1A/5A, Ara Damansara, 47301 Petaling Jaya, Selangor.](#)

☎ +603-7455 0555 📠 +603-7734 7526

Lot 11-14, MRO Centre, MIAC, Sultan Abdul Aziz Shah Airport, 47200 Subang, Selangor.

☎ +603-7734 7226 📠 +603-7734 7526

On Thu, Feb 29, 2024 at 9:15 AM Le Van Minh, Ivan PWC <ivan.le@pwc.ca> wrote:

Hi Addinie,

Thanks for your query.

Allow me to review and get back to you this afternoon.

Regards,

Ivan LE
Manager - Field Support
Pratt & Whitney Canada
MALAYSIA

Mobile : [+6 012 648 4264](tel:+60126484264)
email : ivan.le@pwc.ca

For 24-hour Global Service
Customer First Centre(CFirst)
Tel : [+1 450 647 8000](tel:+14506478000)
email : cfirst@pwc.ca

Connect with P&WC through live video. Talk to your local FSM for details about using Onsite.

This e-mail, including attachments, contains no technical data controlled by the United States Munitions List (USML), or more restrictively controlled than ECCN 9E991 on the United States Commerce Control List (CCL) (i.e. this email may contain EAR99, ECCN 9E991 or other data that is controlled only for Group E:1 countries). This email, along with any attachments, is intended only for the addresses. Any unauthorized disclosure, use, copying, or distribution of the contents of this message, including attachments, is strictly prohibited. If received in error, please promptly notify the sender, and delete the original and all copies from your system.

On 28 Feb 2024, at 23:14, Wan Nur Addinie Wan Mohd Rahimi <addinie.galaxy@gmail.com> wrote:

Dear Ivan,

Attached is our engine component & life limited parts log in strip report attached which requires **URGENT** verification.

We had some discrepancies during our internal audit. Might really need your kind assistance on this matter.

As per the requirement of SB 13002, hub compressor are required to replace as a life limited component.

But refer to the strip report attached, there is no status of p/n 3036211 (hub compressor) nor its alternate p/n included.

Thus we are unable to justify if the component are really replaced or not.

Due to the situation above, it would really help if you could answer the questions below:-

- 1) During engine overhaul, does it include the replacement of a hub compressor?
- 2) Is Hub, Comp - 1st Stage Part No. 3036211 Item 340 (yellow) included in the Rotor assembly, Compressor Item 281 (green) as highlighted below?
- 3) Kindly re-verify the hub compressor 1st stage part number 3036211 as Item 281 describes the rotor compressor assembly.

<image.png>

Very much awaiting your response. Thank you.

Regards,

Addinie Rahimi

TECHNICAL SERVICE CAMO

for and on behalf of

GALAXY AEROSPACE (M) SDN BHD



No. A-01-02, Blok A, Bangunan Perdagangan Siera [Ara Damansara, Jalan PJU 1A/5A, Ara Damansara, 47301 Petaling Jaya, Selangor.](#)

 +603-7455 0555  +603-7734 7526

Lot 11-14, MRO Centre, MIAC, Sultan Abdul Aziz Shah Airport, 47200 Subang, Selangor.

 +603-7734 7226  +603-7734 7526

<SB13002.pdf>

<strip report 053-03-18.pdf>