

AIRCRAFT ACCEPTANCE / HANDOVER INSPECTION FORM

A/C TYPE:	ROBINSON R44
A/C REG:	N8372K
A/C SN:	1099
CLIENT:	MEDITECH

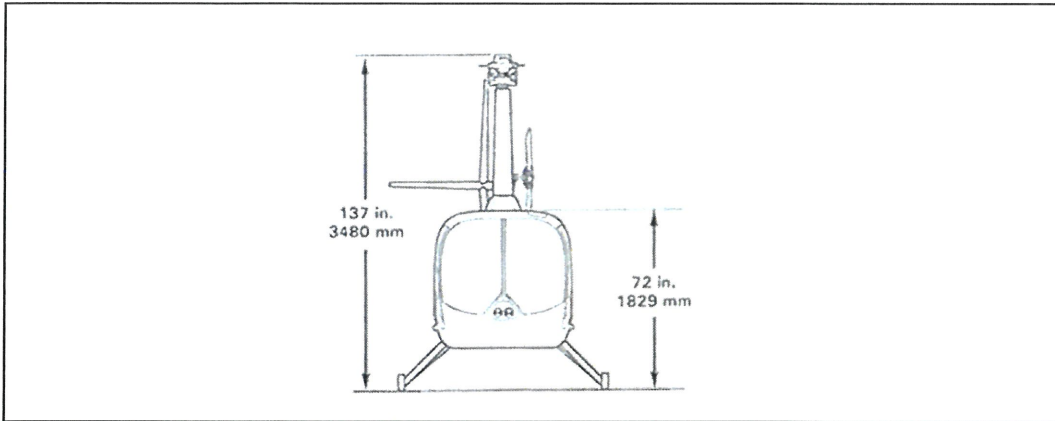



FIGURE 1: NOSE AREA

NO	NOTES/FINDINGS	INSPECTED BY	VERIFIED BY
1	NILL	<i>Arif</i> ARIF	

AIRCRAFT ACCEPTANCE / HANDOVER INSPECTION FORM

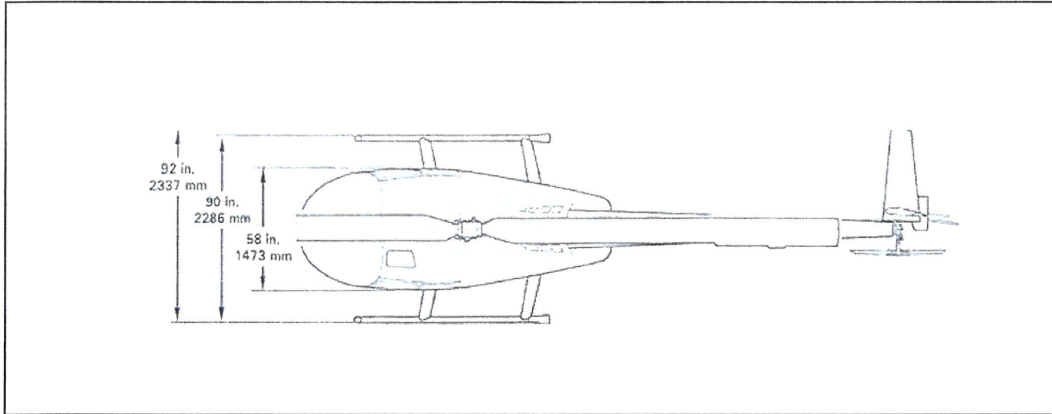

FIGURE 2: TOP AREA

NO	NOTES/FINDINGS	INSPECTED BY	VERIFIED BY
1	NIL	 ARIF	

AIRCRAFT ACCEPTANCE / HANDOVER INSPECTION FORM

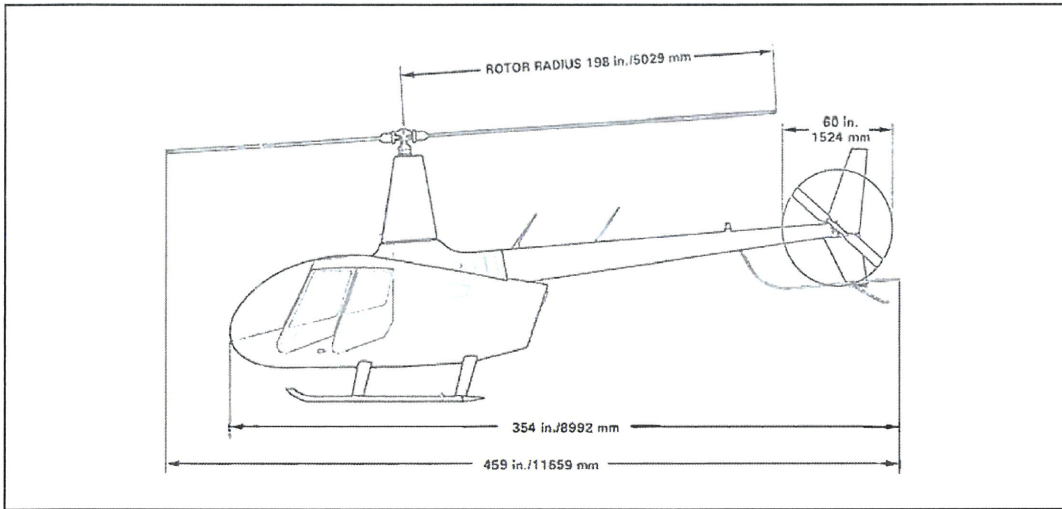

FIGURE 3: LEFT SIDE AREA

NO	NOTES/FINDINGS	INSPECTED BY	VERIFIED BY
1	FWD AND AFT SKID FAIRING NOT INSTALLED	 ARIF	

AIRCRAFT ACCEPTANCE / HANDOVER INSPECTION FORM

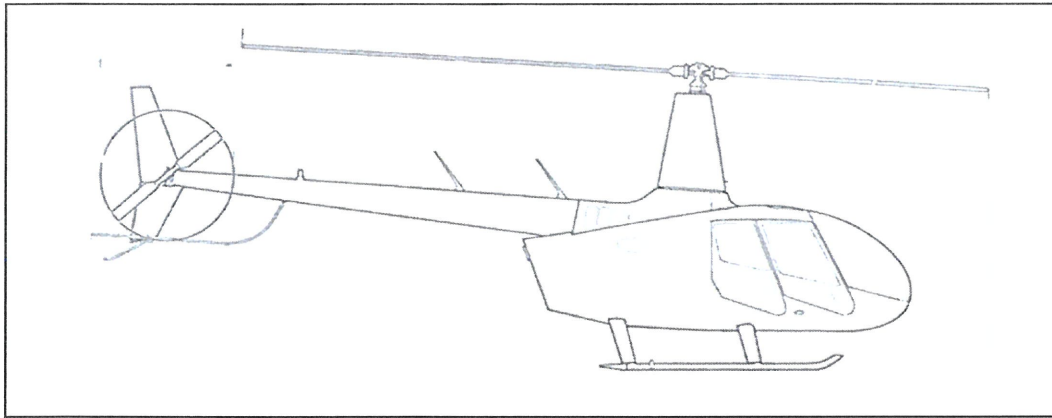



FIGURE 4: RIGHT SIDE AREA

NO	NOTES/FINDINGS	INSPECTED BY	VERIFIED BY
1	FWD AND AFT SKID FAIRING NOT INSTALLED	 ARIF	
2	TRACE OF PAINT PEEL OFF NEAR RIGHT AFT DOOR		

AIRCRAFT ACCEPTANCE / HANDOVER INSPECTION FORM

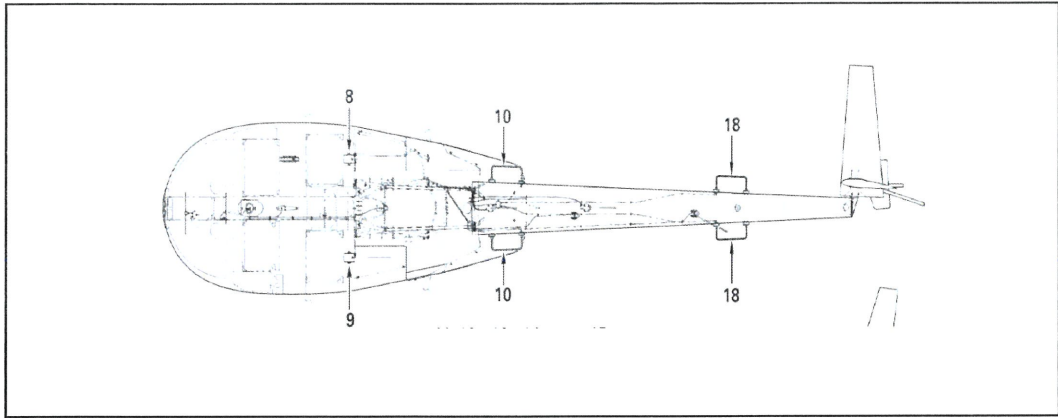

FIGURE 5: BELLY AREA

NO	NOTES/FINDINGS	INSPECTED BY	VERIFIED BY
1	NIL	 ARIF	

AIRCRAFT ACCEPTANCE / HANDOVER INSPECTION FORM

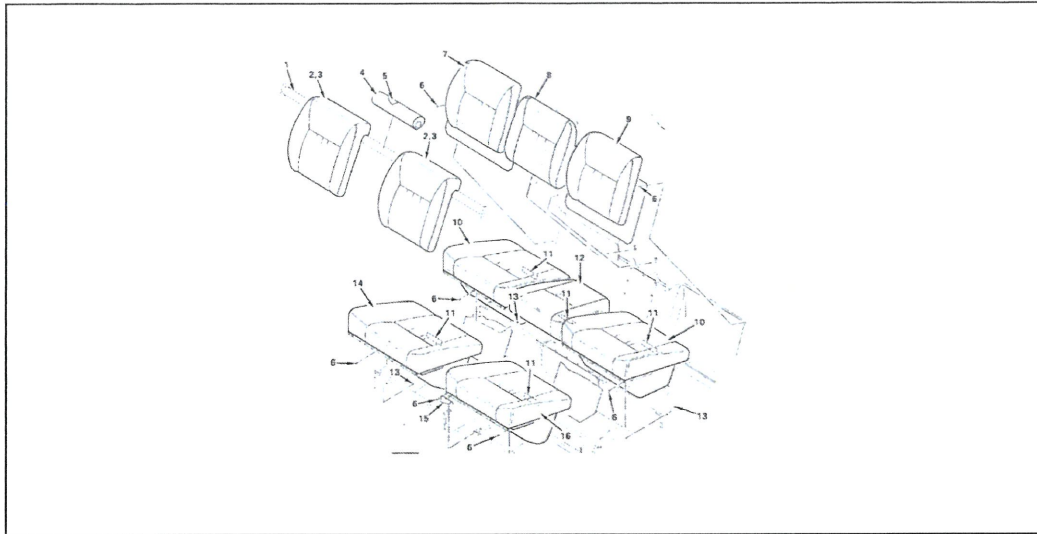





FIGURE 6: SEATS



NO	NOTES/FINDINGS	INSPECTED BY	VERIFIED BY
1	NIL	 ARIF	

AIRCRAFT ACCEPTANCE / HANDOVER INSPECTION FORM

COCKPIT



NO	NOTES/FINDINGS	CHECKED BY	VERIFIED BY
1	NIL	 ARIF	

CABIN



NO	NOTES/FINDINGS	CHECKED BY	VERIFIED BY
1	NIL	 ARIF	

AIRCRAFT ACCEPTANCE / HANDOVER INSPECTION FORM

BAGGAGE COMPARTMENT



NO	NOTES/FINDINGS	CHECKED BY	VERIFIED BY
	N/A	 ARIF	

OTHERS

NO	NOTES/FINDINGS	CHECKED BY	VERIFIED BY
1	NIL	 ARIF	

AIRCRAFT ACCEPTANCE / HANDOVER INSPECTION FORM

LOOSE ITEM CHECK LIST

NO	NOTES/FINDINGS	CHECKED BY	VERIFIED BY
1	GROUND HANDLING WHEEL		
2	PITOT COVER		
3	AIRCRAFT POH		
4	2 UNIT OF HEADSET	 ARIF	
5	WINDOW SHADE		
6	MRB TIE DOWN KIT		
7	AIRCRAFT KEY		

SECTION A: ACCEPTANCE FROM CLIENT

I hereby verify that a physical inspection has been carried out with the above notes/findings, prior to aircraft handing-over to Galaxy Aerospace (M) Sdn Bhd :

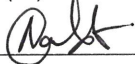
GAM Representative Signature : 

NAME : ARIF

DATE : 31/5/2024

I hereby acknowledge handing-over of the aircraft to Galaxy Aerospace (M) Sdn. Bhd. with the above-mentioned notes/findings after verification with Galaxy Aerospace representative:

CLIENT Representative Signature: 

NAME: YANG KUANG YING

DATE: 31/5/2024

AIRCRAFT ACCEPTANCE / HANDOVER INSPECTION FORM

INSTRUCTION FOR COMPLETING AIRCRAFT ACCEPTANCE / HANDOVER INSPECTION FORM

A/C TYPE:	State the aircraft type
A/C REG:	State the aircraft registration
A/C SN:	State the aircraft serial number
CLIENT:	State the aircraft received from which company or customer
NOSE AREA:	PPC insert front view of the aircraft to mark the finding location.
TOP AREA:	PPC Insert top view of the aircraft to mark the finding location.
LEFT SIDE AREA:	PPC Insert left hand side view of the aircraft to mark the finding location.
RIGHT SIDE AREA:	PPC Insert right hand side view of the aircraft to mark the finding location.
BELLY AREA	PPC Insert belly view of the aircraft to mark the finding location.
SEATS	PPC Insert seats view of the aircraft to mark the finding location.
NOTES/FINDING:	LAE remarks any abnormalities found on the parts of the aircraft received together with an actual picture.
CHECKED BY:	Fill in signature and name of GAM representative
VERIFIED BY:	Fill in signature and name of CLIENT representative
GAM Representative Signature :	Fill in signature of GAM representative
NAME:	Fill in name of GAM representative
DATE:	Fill in date of inspection
CLIENT Representative Signature:	Fill in signature of customer representative
NAME:	Fill in name of customer representative



