

ICN-39-A-124300-G-00001-10124-A-003-01

Figure 1 MLG microswitches test box (Liebherr landing gear) - Disconnect procedures

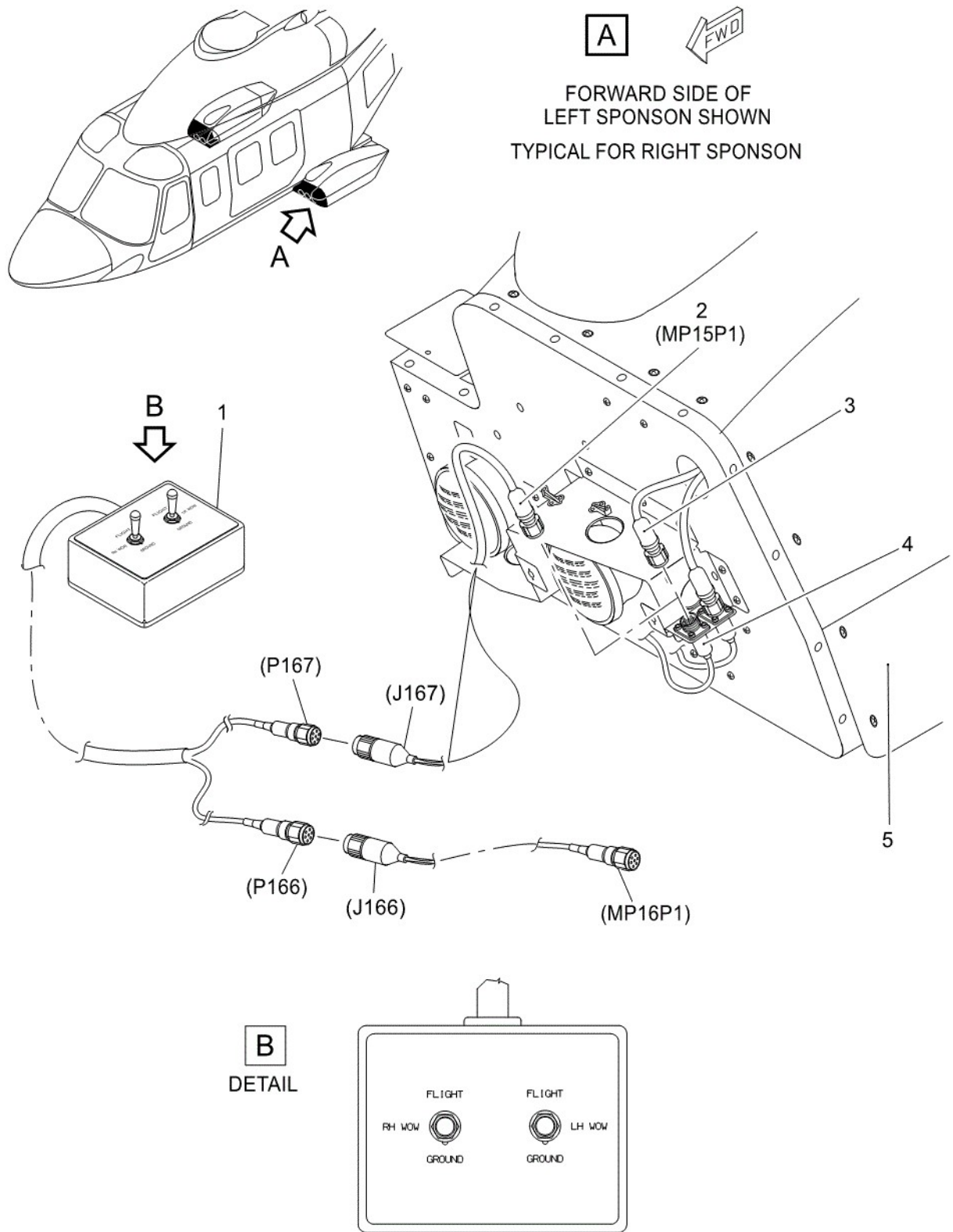

ICN-39-A-124300-G-00001-17591-A-001-01

Figure 2 MLG microswitches test box (Goodrich landing gear) - Disconnect procedures